

TECHNICAL INSTRUCTIONS
FOR
SAFETY RECALL J0A/J0B/J0C
FRONT PASSENGER AIRBAG INFLATOR MODULE
CERTAIN 2003 – 2008 MODEL YEAR COROLLA

UPDATE 08/26/2020

Update 08/26/2020

- Line art on page 19 has been updated

Update 05/28/2020

- Airbag Sub-Assembly replacement has been added as an additional repair option if airbag assemblies are not available.

Update 11/15/2019

- The scanning process has been updated

Update 10/17/2019

- The model year has been extended to 2008 model year

Update 8/28/2019

- The scanning application process has changed. Please review the technical instructions for the details on this change
- The parts sections has been updated

Update 6/13/2019

- The scanning process for unreadable airbag assembly has been revised

Update 6/9/2019

- The scanning process has been updated

Update 12/18/2018

- The images have been updated to reflect the new parts

All dealership technicians performing this recall are required to successfully complete the most current version of the E-Learning course "Safety Recall and Service Campaign Essentials". To ensure that all vehicles have the repair performed correctly; technicians performing this recall repair are required to have successfully completed E-Learning course SC18A (if you had previously completed E-Learning Course SC13B, you do not have to take SC18A), in addition to "Safety Recall and Service Campaign Essentials", and currently hold at least one of the following certifications levels:

- Toyota Certified (Electrical)
- Toyota Expert (Any Specialty)
- Master
- Master Diagnostic Technicians

I. OPERATION FLOW CHART

The flow chart is for reference only. **DO NOT** use it in place of the full technical instructions. Follow **ALL** steps as outlined in the full technical instructions to confirm the campaign is completed correctly.

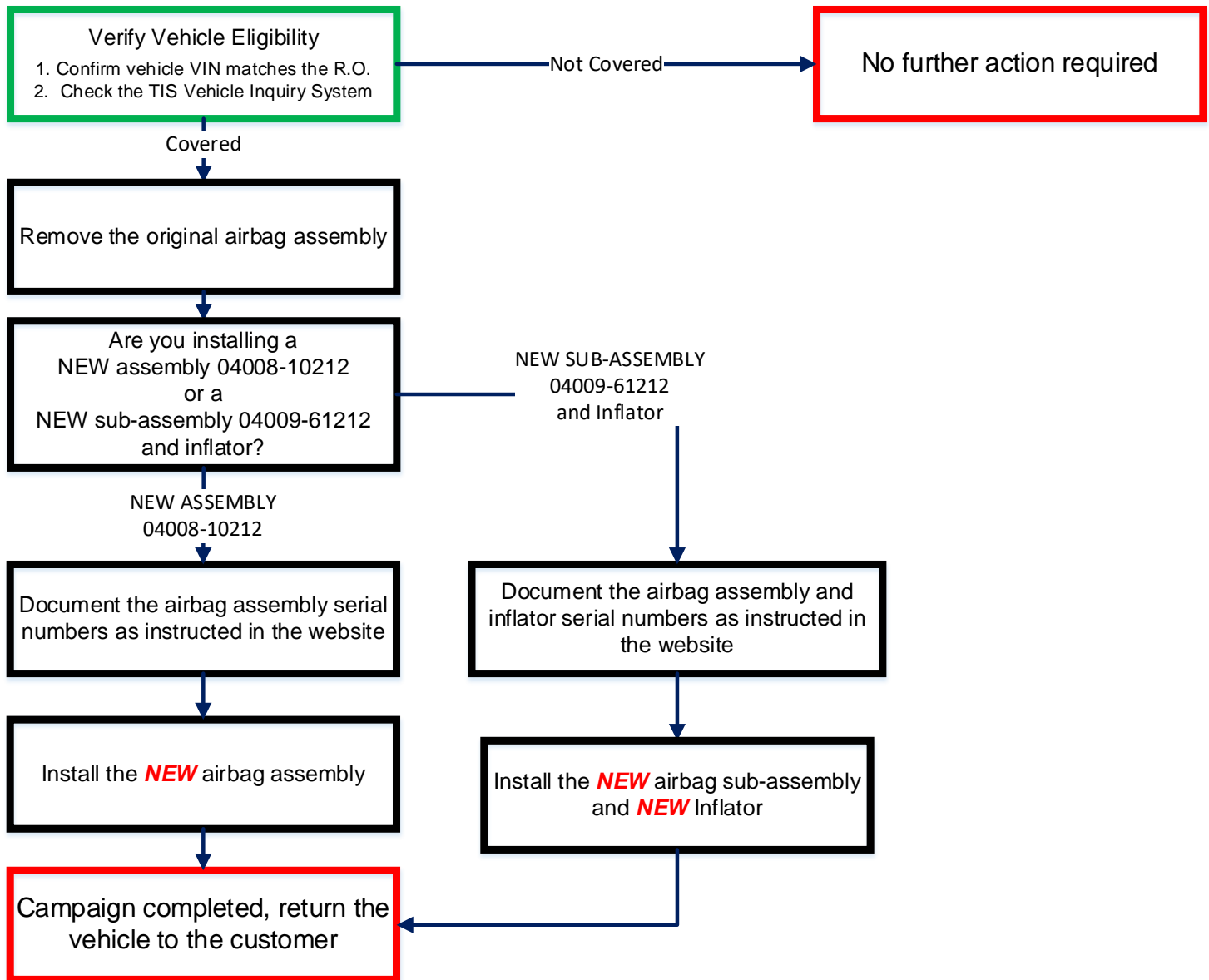

II. BACKGROUND

The subject vehicles are equipped with front passenger airbag inflators produced by Takata. The propellant in these inflators may degrade after prolonged exposure to high absolute humidity and fluctuating high temperatures. Degraded propellant can cause the inflator to explode during airbag deployment. In the event of an inflator explosion, metal fragments could pass through the airbag cushion material, striking the vehicle occupants, and result in serious injury or death.

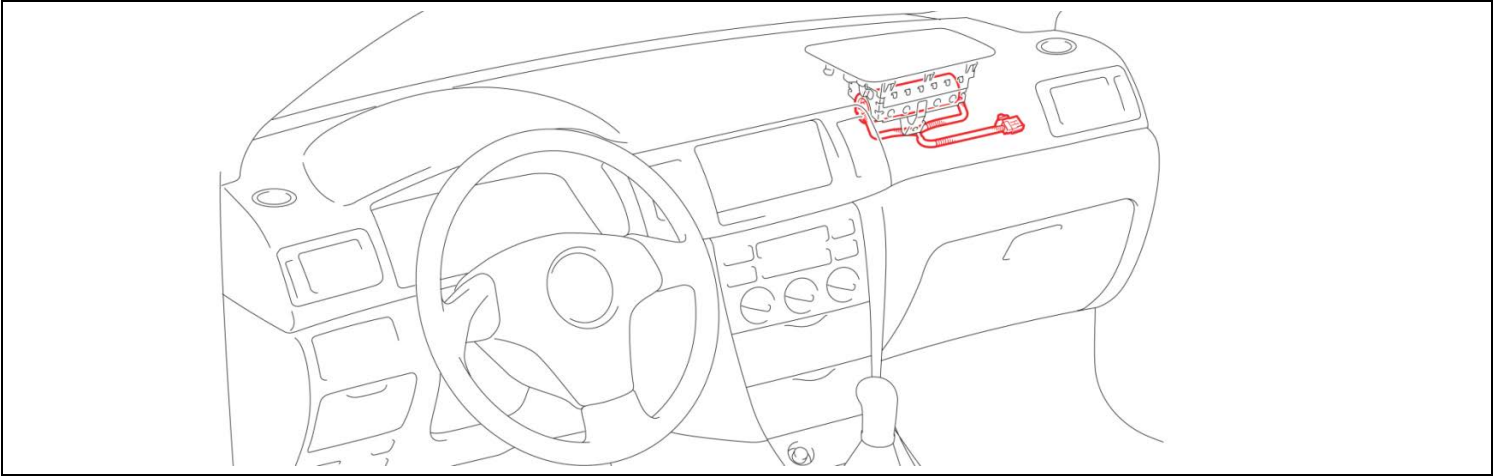

III. IDENTIFICATION OF AFFECTED VEHICLES

- Check the TIS Vehicle Inquiry System to confirm the VIN is involved in this Safety Recall, and that the campaign has not already been completed prior to dealer shipment or by another dealer.
- **TMS warranty will not reimburse dealers for repairs conducted on vehicles that are not affected or were completed by another dealer.**

IV. PREPARATION

A. PARTS

Model	Part Number	Part Description	Quantity
2003-2008 MY Corolla	04008-10212	AIR BAG ASSY KIT, INSTR PNL PASS	1

Dealers should discontinue the installation of the parts listed below for the recalls, customer pay repairs AND over-the-counter sales (if applicable) unless they have a mark on the label.



Make sure the parts box has a check mark as seen in the image above

OR

Model	Part Number	Part Description	Quantity
2003-2008 MY Corolla	04009-61212	AIR BAG KIT	1
	04008-10312	INFLATOR ASSY KIT, INSTR PNL AIR BAG	1

NOTE: Continue to order 04008-10212 until there is no longer stock at your facing PDC. Once there is no longer stock of the airbag assembly part number 04008-10212 use the airbag kit part number 04009-61212 and inflator kit part number 04008-10312 to perform the remedy for Corolla vehicles.

****If there is no longer stock of 04008-10212 and the airbag assy serial number is missing or not legible, use the service module part number to complete the campaign. In these cases do not use the scan app. Instead fill out a job aid and submit to quality_compliance@toyota.com.**

A. TOOLS & EQUIPMENT

- Standard hand tools
- Molding remover set
- Torque wrench
- Techstream
- Electrical tape
- Zip Tie

OPTIONAL SST – This is an essential special service tool that the dealership should have. This tool is not mandatory when performing this repair.

Part Number	Part Name	Quantity
09890-47010-01	Anti-Static Mat Set	1

CAMPAIGN TOOLS – These tools were previously provided to the dealership for campaign D0F and will be used for campaign E04. These tools are required when performing this repair.

Image	Name	Quantity
	Airbag Mounting Bracket & hardware	1
	Barcode Scanner	1

NOTE: These tools **CANNOT** be ordered through the parts or tools system. There is a very limited supply of tools, but if additional tools are needed, contact your regional representative.

V. SAFETY PRECAUTIONS



CRITICAL INFORMATION – READ THOROUGHLY



Failure to follow these procedures correctly could cause the SRS to unexpectedly deploy during servicing or the SRS may fail to operate correctly when required after reassembly. Confirm all work is performed as described in these instructions.

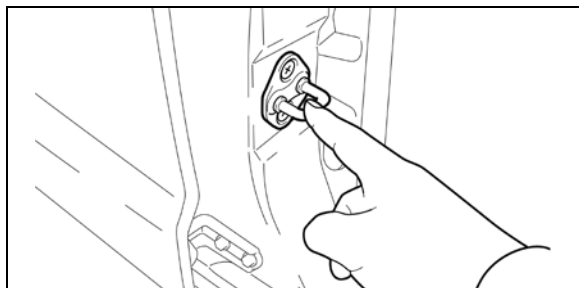

1. ELIMINATE STATIC ELECTRICITY

- Before starting work and periodically while working on the vehicle, touch a metallic part of the vehicle to discharge static electricity in the body.

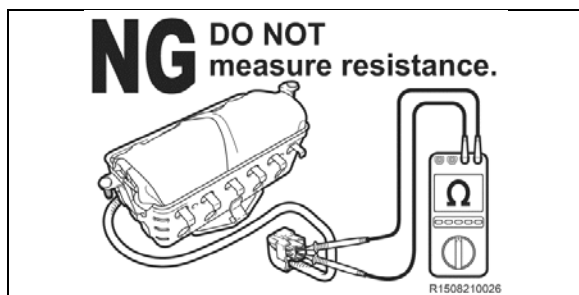

2. DO NOT MEASURE RESISTANCE

- DO NOT** measure resistance of airbag components, this may cause accidental activation.

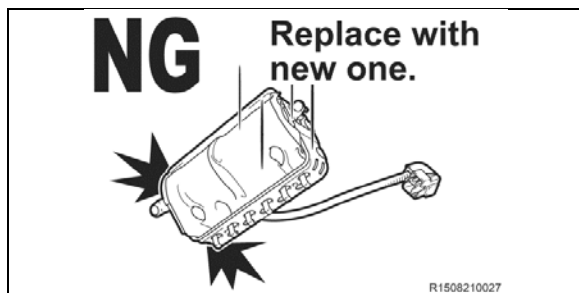

3. HANDLE THE AIRBAG CAREFULLY

- If an inflator is dropped, replace it with a **NEW** module.

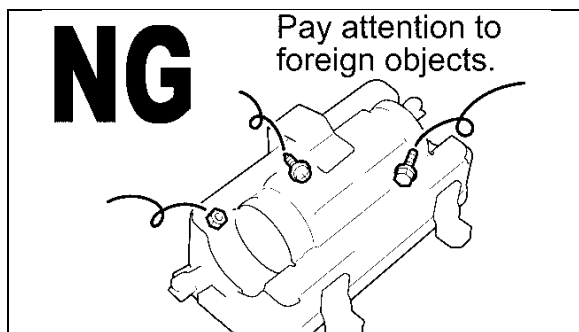

4. DO NOT ALLOW FOREIGN OBJECTS NEAR AIRBAG

- Be sure to collect and account for all removed nuts/bolts to prevent them from landing in the airbag assembly.
- Any foreign objects in the airbag assembly may cause damage or injury if the airbag is activated.

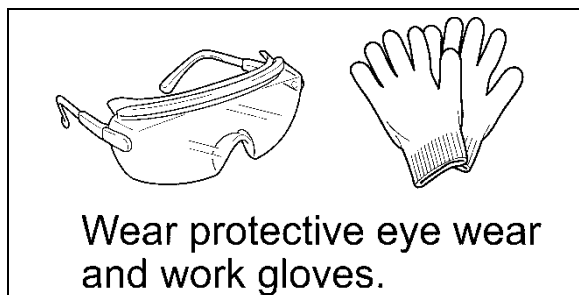

5. WEAR PROTECTIVE EQUIPMENT

- Always wear appropriate protective equipment when working on the SRS.

VII. PASSENGER AIRBAG ASSEMBLY REPLACEMENT

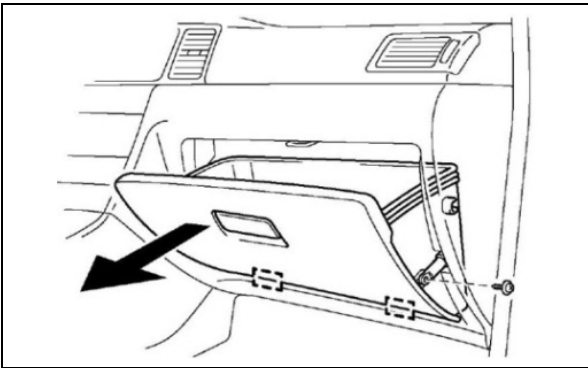

1. REMOVE THE GLOVE BOX

- Remove the screw and disconnect the stopper sub-assembly.
- Completely remove the glove box from the dashboard.

2. REMOVE THE AIRBAG ASSEMBLY

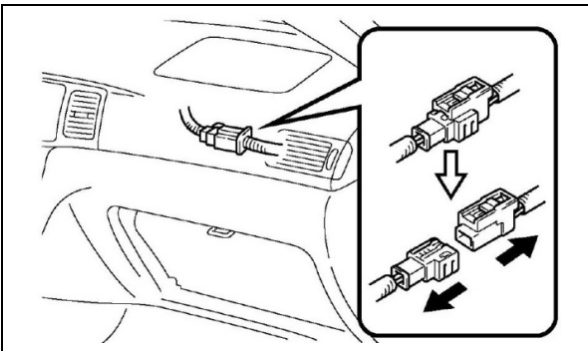

- Disconnect the negative battery cable.



- Wait at least 90 seconds after disconnecting the cable from the negative battery terminal to prevent airbag and seat belt pre-tensioner deployment.
- Follow all precautions as outlined on TIS before servicing the SRS system.

- Disconnect the airbag connector.

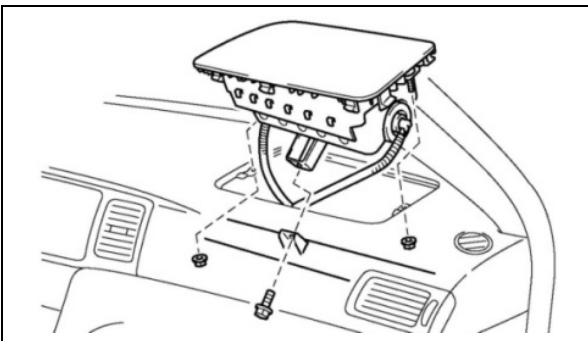

- Remove the bolt and 2 nuts and remove the airbag assembly.
NOTE: Use caution to avoid scratching or damaging the dashboard assembly, place protective tape on the dashboard if needed.

3. CONNECT THE BARCODE SCANNER

- Connect the barcode scanner to the USB port on the Techstream.
- The scanner will automatically connect and a beep will be heard when the scanner is ready.

NOTE:

- The scanner was provided for SSC D0F.
- The scanner works best in low light conditions.
- Always hold the scanner directly in front of and parallel to the barcode label.

Campaign Phase Interpretation

REMEDY PHASE – ELIGIBLE FOR REPAIR

Campaign Description: Safety Recall J0A - Remedy Notice - Multiple Models - Non-Desiccated Front Passenger Airbag Inflator – “Like for Like” Replacement (Zone A)
Campaign Status: Remedy Available
Completion Status: Not Completed
Memo: Remedy Available

[Show Documents]

STATUS IDENTIFICATION

A: Campaign Status: Remedy Available

B: Memo: Remedy Available

- **This vehicle is eligible to have the remedy performed if the completion status is “Not Completed.”**
- **The original scanning application link can be used.**

Campaign Description: Safety Recall J0A - Remedy Notice - Certain 2003 - 2005 Corolla - Non-Desiccated Front Passenger Airbag Inflator – “Like for Like” Replacement (Zone A)
Campaign Status: Remedy Available
Completion Status: Not Completed
Memo: Remedy Available - Instead of using the scanning application use <https://takata-scan-app.imagespm.info/>

[Show Documents]

STATUS IDENTIFICATION

A: Campaign Status: Remedy Available

B: Memo: Remedy Available – Instead of using the scanning application use <https://takata-scan-app.imagespm.info/>

- **This vehicle is eligible to have the remedy performed if the completion status is “Not Completed.”**
- **The new scanning application website <https://takata-scan-app.imagespm.info/> must be used when performing the remedy.**
- **Login instructions for this new scanning application website are included in the Technical Instructions.**

4. LAUNCH THE SERIAL NUMBER RECORDING APPLICATION



- The ORIGINAL AIRBAG ASSEMBLY, and NEW ASSEMBLY serial numbers MUST be recorded using the barcode scanner.
- The barcode scanner application MUST be completed on every vehicle. These numbers MUST be included on every warranty claim that is submitted for inflator module replacement or the claim may be subject to debit.
- The technician performing the work MUST have an internet connection to perform the inspection and scanning process.

- a) Log into the website via the URL below
<https://takata-scan-app.imagespm.info/>
- b) **User ID:** Dealer Code
First time login password: xxxxx

The screenshot shows a login page with the heading "Login" and the instruction "Complete all required (*) fields below." There are two input fields: "* User ID (enter your 5-digit dealer code, or 6-digit for Canadian dealers eg. Cnnnnn format):" and "* Password:". Below the fields is a blue "Login" button and a link for "Forgot Password?".

The screenshot shows a "Technician Information" page with the instruction "Please provide information below before searching for VIN." There are two input fields: "Technician Name:" and "SPIN ID (12 digit code):". Below the fields is a blue "Search" button.

- c) Enter your name and SPIN ID into the site

The screenshot shows an "Enter VIN" page with the instruction "Enter the 17-digit Vehicle Identification Number to begin the search for this campaign." There are two input fields: "VIN:" and "Mileage on Vehicle:". Below the fields is a blue "Search" button.

- a) Enter the VIN and vehicle mileage into the site

5. FOLLOW THE INSTRUCTIONS IN THE SITE FOR RECORDING SERIAL NUMBERS

- a. Follow the prompts and fill in the requested information in the website.
- b. Once completed, record the Warranty Authorization number if given and provide it to your warranty clerk.

**VIII. PASSENGER AIRBAG ASSEMBLY REPLACEMENT (Part Number 04008-10212)
(for airbag sub-assembly part number 04009-61212 and inflator part number
04008-10312 replacement go to page 12)**

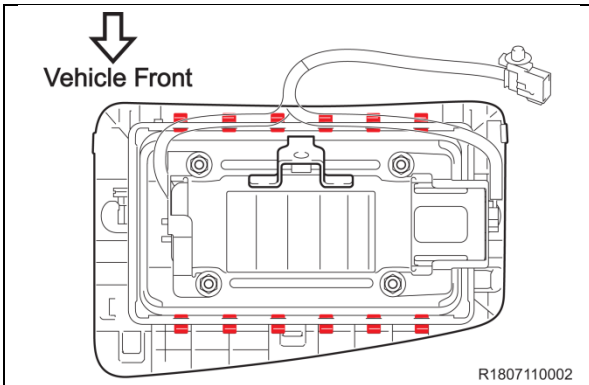

5. INSTALL THE INSTRUMENT PANEL PASSENGER AIRBAG ASSEMBLY COVER

- a) Install a **NEW** instrument panel passenger airbag taking care not to mistake the mounting direction.
- b) Check that the 12 claws of the instrument panel passenger airbag have engaged securely.

6. REINSTALL THE AIRBAG ASSEMBLY

Note: During reinstallation of the airbag assembly, ensure the 12mm bolt and two 10mm nuts securing the airbag assembly to the instrument panel are installed and torqued to the required specification identified on TIS.

- a) Refer to TIS for instructions on airbag installation:

Corolla [2003-2005MY](#) [2006MY](#) [2007MY](#) [2008MY](#)

7. RECONNECT THE NEGATIVE BATTERY CABLE

8. PERFORM A HEALTH CHECK AND DIAGNOSTIC REPORT

◀ VERIFY REPAIR QUALITY ▶

- Confirm all precautions are followed to ensure safety during the repair
- Confirm the entire serial number checker application is completed and the warranty authorization # is recorded on **EVERY** vehicle
- Confirm the old airbag assembly is handled safely and given to the appropriate parts professional for shipment

If you have any questions regarding this update, please contact your regional representative.

IX. AIRBAG SUB-ASSEMBLY AND INFLATOR REPLACEMENT (Part Number 04009-61212 and 04008-10312)

(only required if airbag assembly part 04008-10212 is unavailable)

STOP CRITICAL INFORMATION – READ THOROUGHLY STOP

The connector of the inflator module contains a short circuiting mechanism to eliminate voltage variances when the connector(1) is disconnected. To allow for the replacement of the inflator module, a new short circuit(2) **MUST** be created before cutting the wires(3) and removing the inflator. The following steps **MUST** be followed exactly as described to ensure the work is completed correctly and safely.

(1)
Short circuiting on both sides.

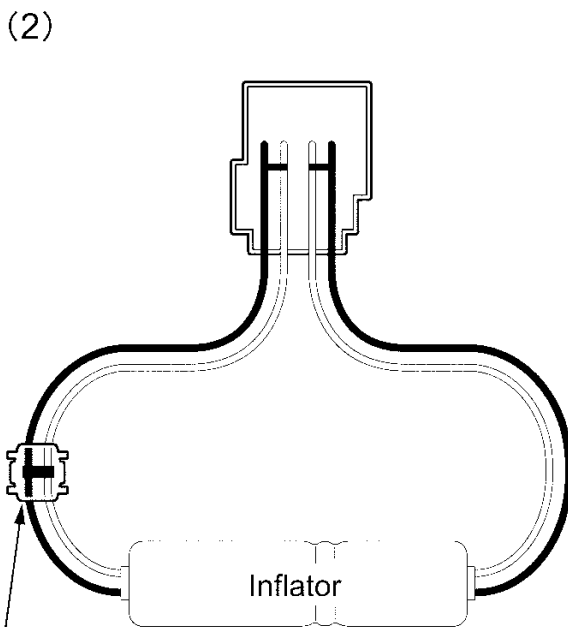
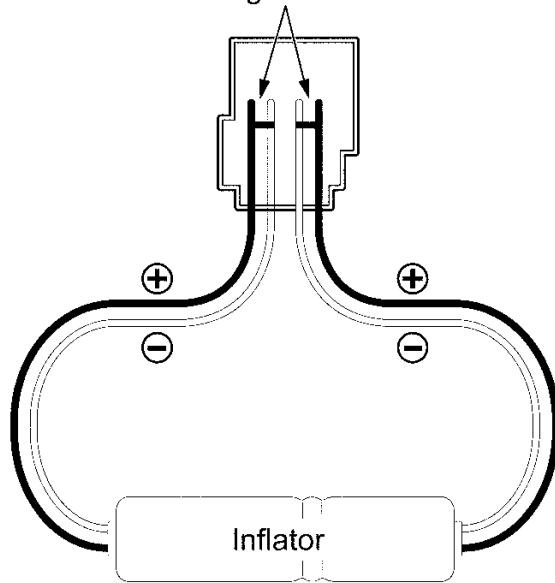

Create new short circuit using electro tap.

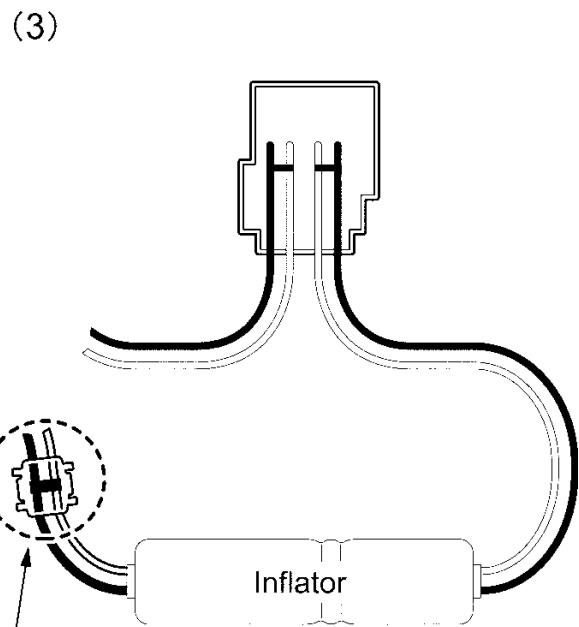

Short circuiting is maintained even after cutting harness.

R1302250036E

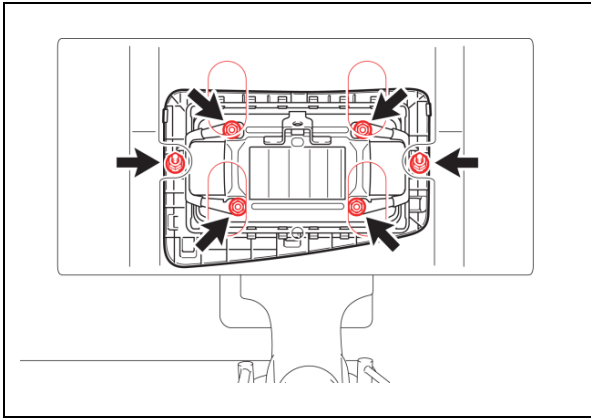
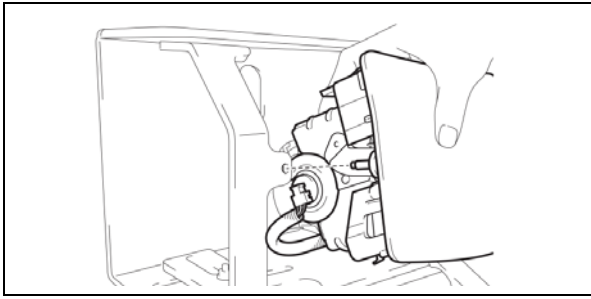

1. MOUNT THE AIRBAG IN THE MOUNTING BRACKET

- a) Position the two mounting studs on the airbag assembly into the holes on the bracket support bars.
- b) Install the airbag to the support bars with the nuts supplied in the bracket kit.
- c) Position the airbag so that all four stopper plate nuts can be removed through the access holes.
- d) Tighten the nuts holding the support bars to the mounting bracket.
- e) Confirm the following:
 - Mounting bracket is secure in the vise.
 - Airbag is secure in the support bars.
 - The center mounting bracket on the airbag assembly is facing upward.
 - Support bars are secure on the mounting bracket using 1 bolt/nut at the top of each support bar and 2 nuts/bolts at the bottom of each support bar.

STOP

CRITICAL INFORMATION – READ THOROUGHLY

STOP

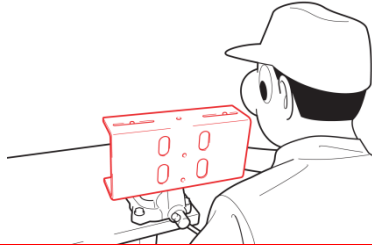

ALWAYS keep as much of your body as possible in front of the bracket when working on the airbag assembly.



Remember to periodically touch a metallic part of the vehicle to discharge static electricity in the body if the anti-static kit is not being used.

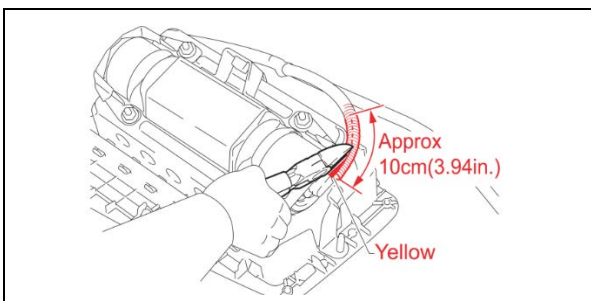

2. PREPARE TO INSTALL THE SHORT CIRCUIT

- a) Cut the yellow corrugated tube on the harness approximately 4 inches (10 cm) using nippers.

STOP

- **DO NOT** damage the wires in the tube.
- **DO NOT** use a knife or razor blade to cut the tube to avoid damaging the wires.
- This may be performed on either end of the inflator.

- b) Cut off the tab of the electro tap shown in the illustration.

NOTE: The electro tap is included in the inflator parts kit.

STOP

This tab **MUST** be removed to ensure a good short.

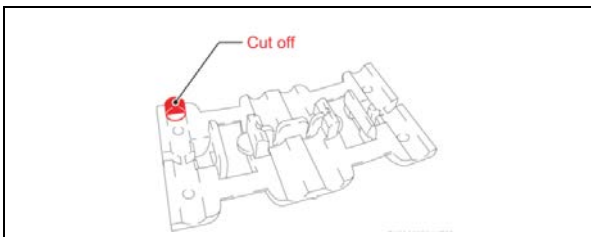

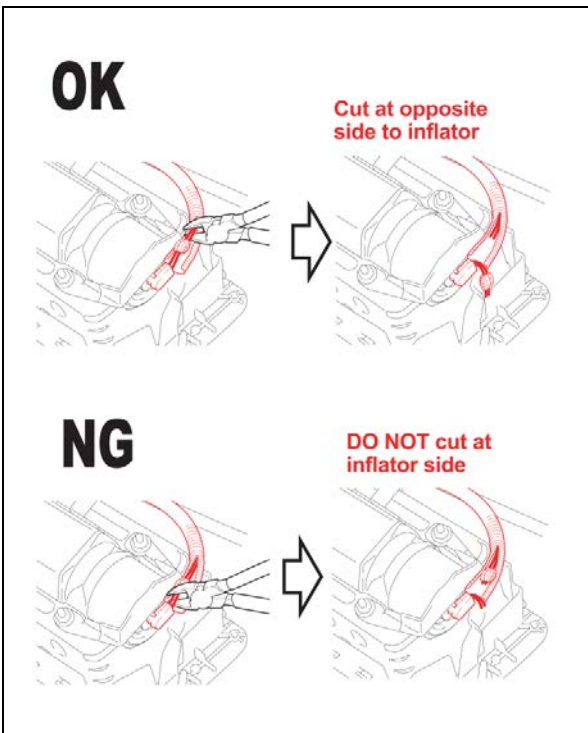
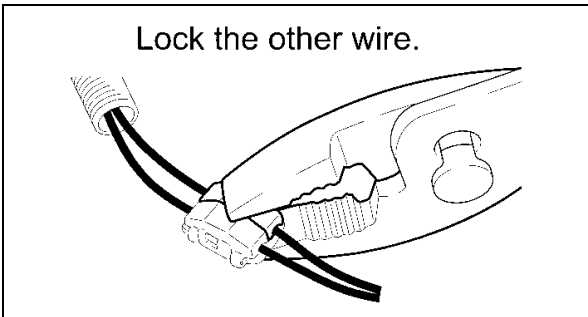
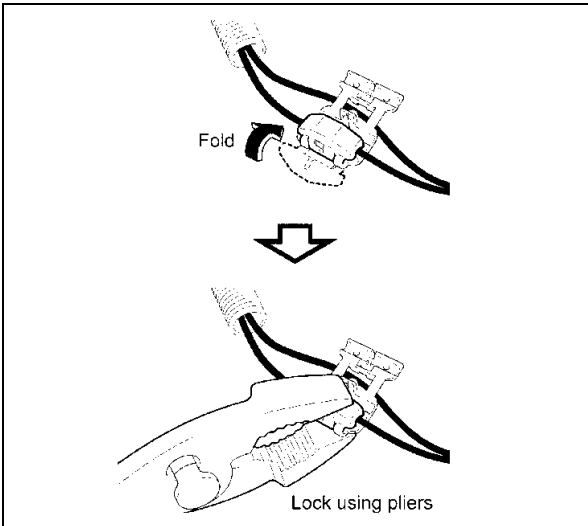
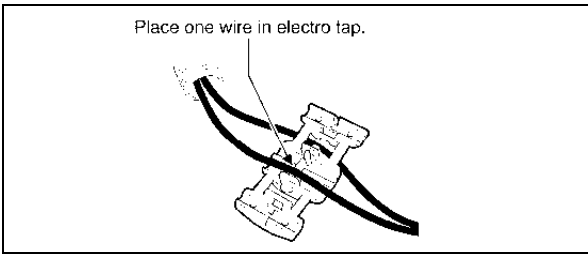

3. CREATE A NEW SHORT CIRCUIT IN THE INFLATOR HARNESS

- a) Place one wire in the electro tap as shown in the illustration.
- b) Fold and pinch the half of the electro tap with the wire and use pliers to lock the electro tap.

NOTE:

- **DO NOT** work on both wires at the same time to avoid errors.
- Pliers **MUST** be used to confirm the electro tap is firmly locked in place.

- c) Set the other wire in the electro tap and lock it in place using pliers.

STOP **DO NOT** measure resistance of the inflator wires, this may cause accidental activation.

4. CUT THE INFLATOR WIRES

- a) Cut the 2 wires at the side of the electro tap that is farthest away from the inflator.

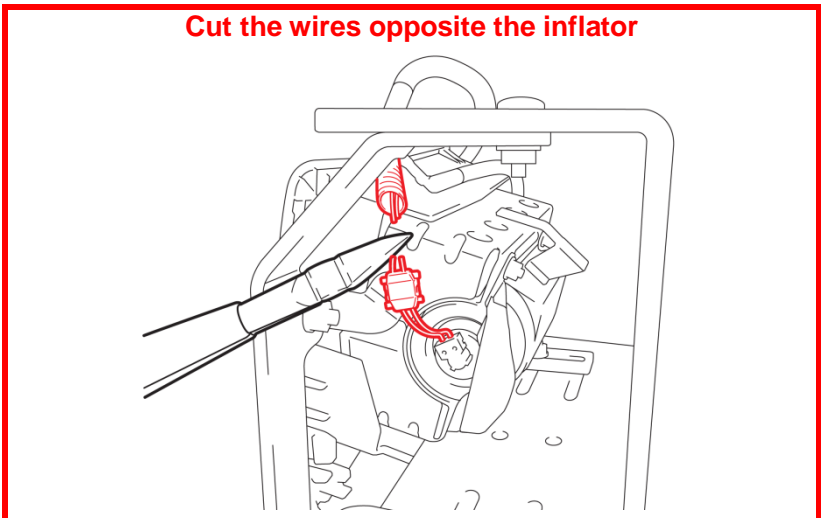

STOP **DO NOT** measure resistance of the inflator wires, this may cause accidental activation.

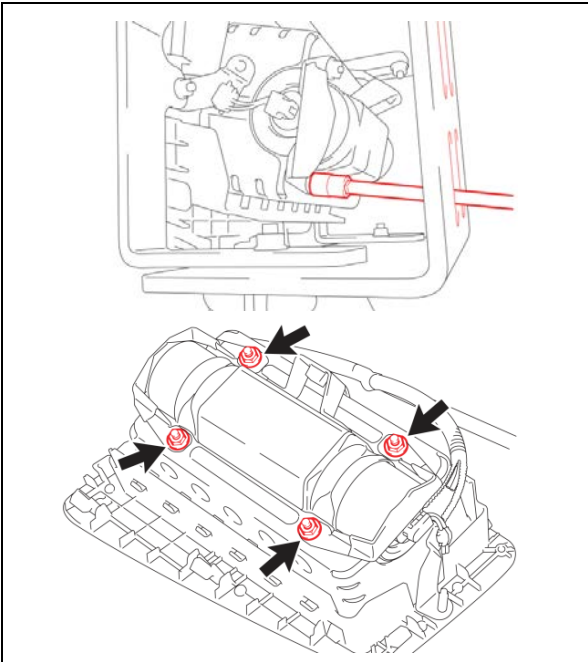

5. REMOVE THE SELF LOCKING NUTS

- a) Use the access holes in the bracket to remove the 4 nuts.

NOTE:

- **DO NOT** use power tools.
- The bracket support bars may need to be repositioned to remove the nuts through the access holes.

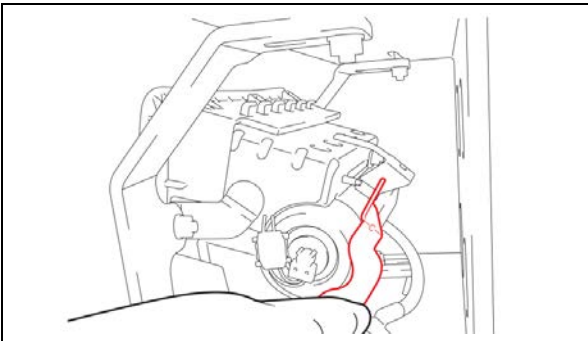

- b) Remove the stopper plates.

- c) Discard the 4 nuts and 2 stopper plates as they are not to be reused.

NOTE: DO NOT reuse the old nuts, new nuts **MUST** be used.

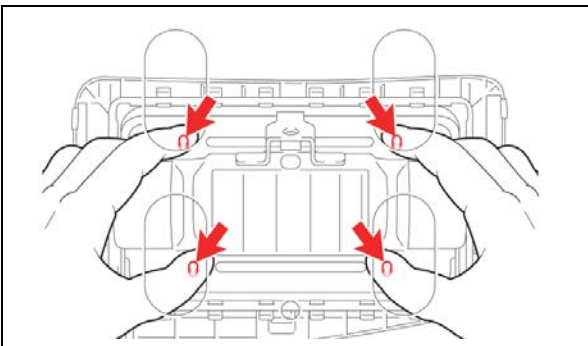

6. REMOVE THE INFLATOR

- a) Gently push in the 4 studs to loosen the inflator for removal.

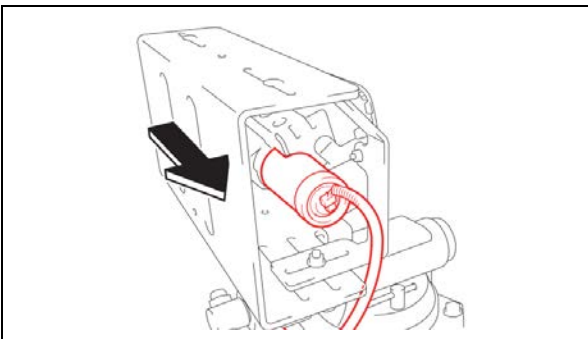

- b) Remove the inflator from the airbag assembly and place it on a safe work surface.

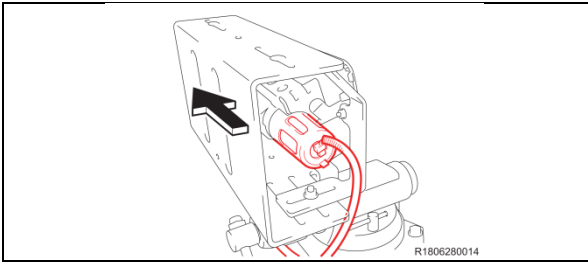

7. INSTALL THE **NEW** INFLATOR

- a) Carefully slide the new inflator into the airbag assembly.



- **DO NOT** connect the inflator harness at this time. It is **CRITICAL** to install the plates first to confirm the inflator is installed in the correct position before connecting the harness.

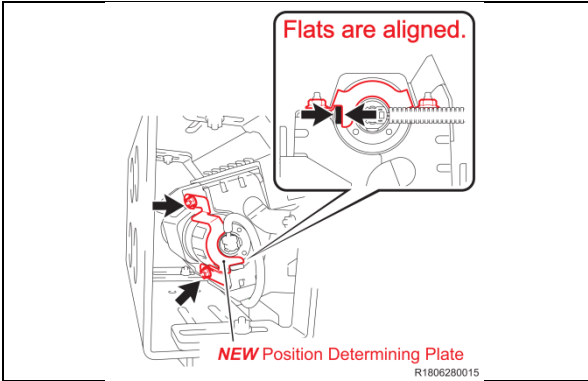

8. INSTALL THE **NEW** POSITION DETERMINING PLATE

- a) Place the **NEW** position determining plate on the side where the harness is already connected.



- Confirm the flats on the position determining plate and inflator are aligned.
- **DO NOT** pinch the harness between the inflator and the plate.

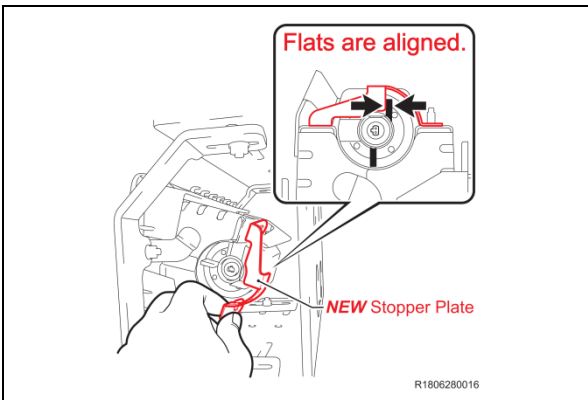

9. INSTALL THE **NEW** POSITION DETERMINING PLATE

- a) Place the **NEW** position determining plate on the airbag assembly on the unconnected side.



- Confirm the flats on the position determining plate and inflator are aligned.

- b. Remove the airbag assembly from the bracket so you may replace the airbag sub-assembly

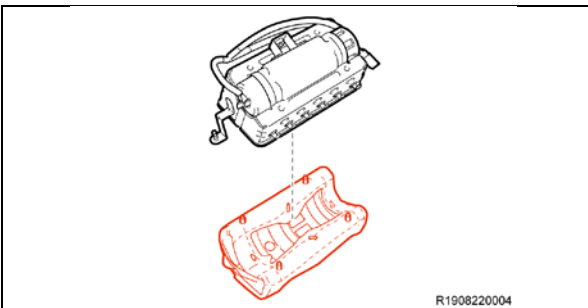

8. REPLACE THE INSTRUMENT PANEL PASSENGER AIRBAG SUB-ASSEMBLY

- a) Remove the instrument panel passenger airbag sub-assembly from airbag case.
 b) Store the removed instrument panel passenger airbag sub-assembly in a replacement part box or other safe location.
 c) Install the **NEW** instrument panel passenger airbag sub-assembly.

- d) Connect the inflator wire harness

- e) Place the inflator following the top-and-bottom orientation shown in the illustration.



- Make sure that the inflator is oriented correctly as shown in the illustration, not upside down.
- If the passenger airbag inflator is upside down, it will not be able to be fully inserted.

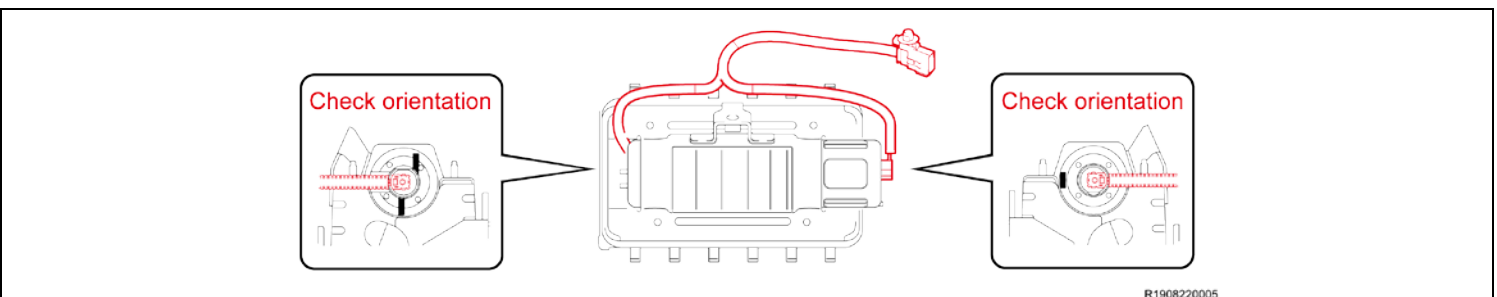

f) Loosely install the plate and airbag inflator with the 2 **NEW** self-locking nuts.



• **DO NOT** mistake the orientation of the plate.

Install loosely
by hand

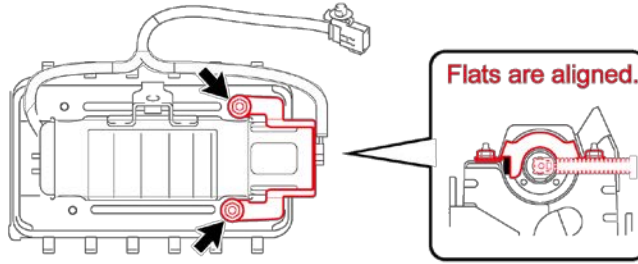

R1908220006

g) Loosely install the plate and airbag inflator with the 2 **NEW** self-locking nuts.

Install loosely
by hand

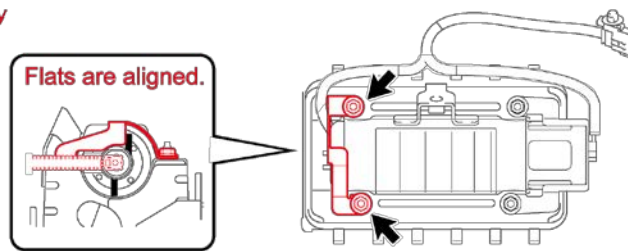

R1908220007

h) Push the inflator and plate to towards the position determining plate to eliminate any gap.



If any gap exists, the aligned flats may move apart, resulting in failure in normal deployment of the airbag.

i) Tighten 5 nuts evenly in several increments in the order shown in the illustration using a socket driver while pushing the inflator and plate. (You will encounter some resistance during tightening because these nuts are self-locking nuts.)

Torque: 3.9 N*m (40 kgf*cm, 35 in.*lbf)



The tightening torque is low (3.9 N-m). Use of an air ratchet wrench, a T-handle wrench, or a ratchet handle may cause the stud bolt to stretch or break.

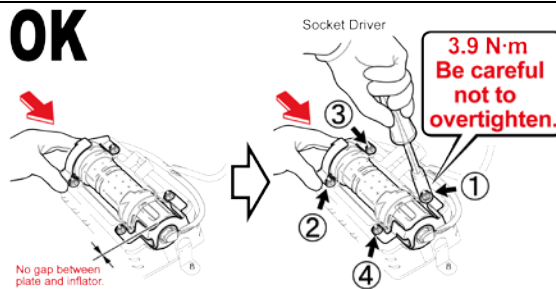

OK **NG** **NG** **NG**



These tools cause overtightening !

R1908220009

9. INTERMEDIATE INSPECTION

- a) Check that the instrument panel passenger airbag sub-assembly and 4 self-locking nuts are replaced.
- b) Check that positions of the inflator and the position determining plate are correct.
(The flats should be aligned and there should be no gap.)

(a) Replacement of parts

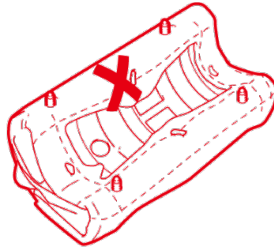

(b) No gap.

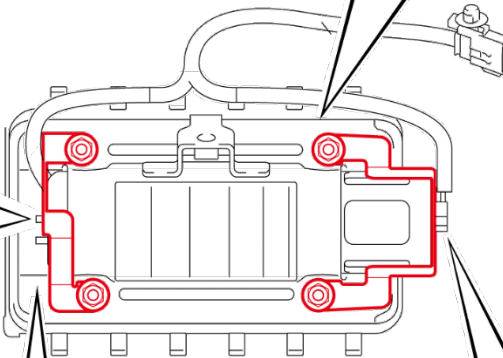
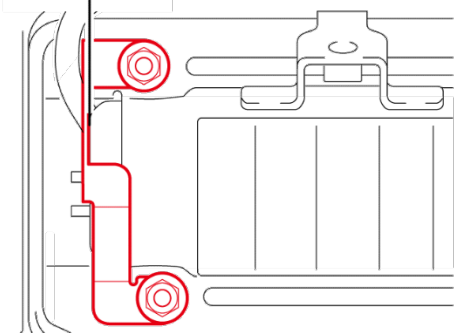

(b) Check orientation

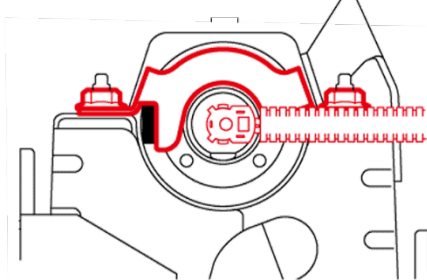

(b) Check orientation

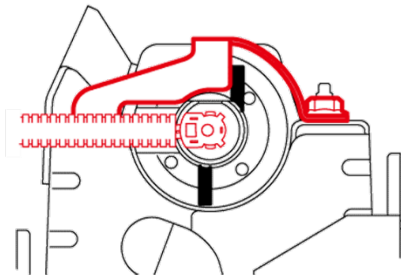

Pass through the side

R1908220003

X. INSTRUMENT PANEL PASSENGER AIRBAG ASSEMBLY W/O DOOR INSTALLATION

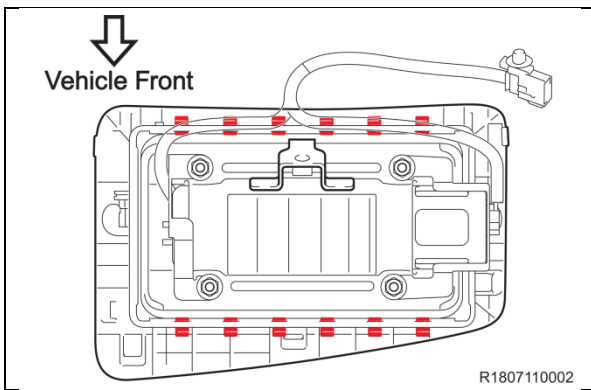

1. INSTALL THE INSTRUMENT PANEL PASSENGER AIRBAG ASSEMBLY W/O DOOR

- Install the instrument panel passenger airbag taking care not to mistake the mounting direction.
- Check that the 12 claws of the instrument panel passenger airbag have engaged securely.

2. REINSTALL THE FRONT PASSENGER AIRBAG ASSEMBLY

Note: During reinstallation of the airbag assembly, ensure the 12mm bolt and two 10mm nuts securing the airbag assembly to the instrument panel are installed and torqued to the required specification identified on TIS.

- Refer to TIS for instructions on airbag installation:

Corolla [2003-2005MY](#) [2006MY](#) [2007MY](#) [2008MY](#)

3. RECONNECT THE NEGATIVE BATTERY CABLE

4. PERFORM A HEALTH CHECK AND DIAGNOSTIC REPORT

◀ VERIFY REPAIR QUALITY ▶

- Confirm all precautions are followed to ensure safety during the repair
- Confirm the entire serial number checker application is completed and the warranty authorization # is recorded on *EVERY* vehicle

If you have any questions regarding this update, please contact your regional representative.

XI. APPENDIX

A. CAMPAIGN DESIGNATION DECODER

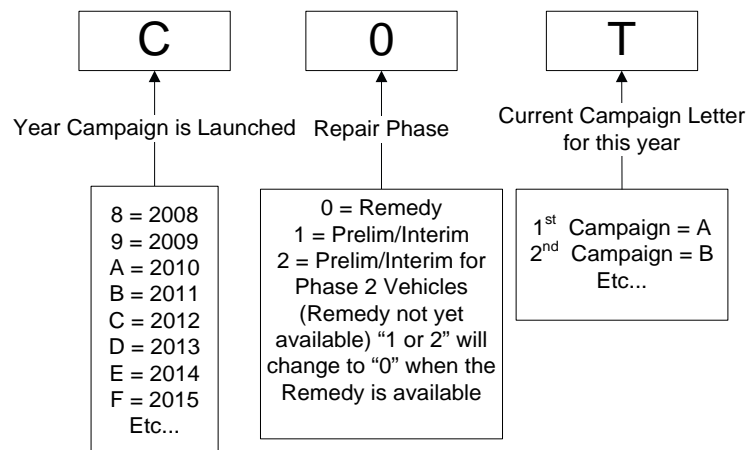

B. CAMPAIGN PARTS DISPOSAL

ALL inflators that are removed from vehicles under this campaign **MUST** be packaged and shipped back to the inflator manufacturer following the manufacturer's instructions. The instructions can be found in the following locations:

- Attached to the dealer letter