

IMPORTANT UPDATE

TECHNICAL INSTRUCTIONS FOR SAFETY RECALL J0A, J0B, J0C FRONT PASSENGER AIRBAG “MODULE” REPLACEMENT ONLY



CERTAIN 2003 – 2008 MODEL YEAR MATRIX

UPDATE 7-17-2018

Update 07-17-18

- The Technician Certification Requirements have changed

All dealership technicians performing this recall are required to successfully complete the most current version of the E-Learning course “Safety Recall and Service Campaign Essentials”. To ensure that all vehicles have the repair performed correctly; technicians performing this recall repair are required to have successfully completed E-Learning course SC18A (if you had previously completed E-Learning Course SC13B, you do not have to take SC18A), in addition to “Safety Recall and Service Campaign Essentials”, and currently hold at least one of the following certifications levels:

- Toyota Certified (Electrical)
- Toyota Expert (Any Specialty)
- Master
- Master Diagnostic Technicians

It is the dealership’s responsibility to select technicians with the above certification level or greater to perform this repair. Carefully review your resources, the technician skill level, and ability before assigning technicians to this repair. It is important to consider technician days off and vacation schedules to ensure there are properly trained technicians available to perform this repair at all times.

I. OPERATION FLOW CHART

The flow chart is for reference only. **DO NOT** use it in place of the full technical instructions. Follow **ALL** steps as outlined in the full technical instructions to confirm the campaign is completed correctly.

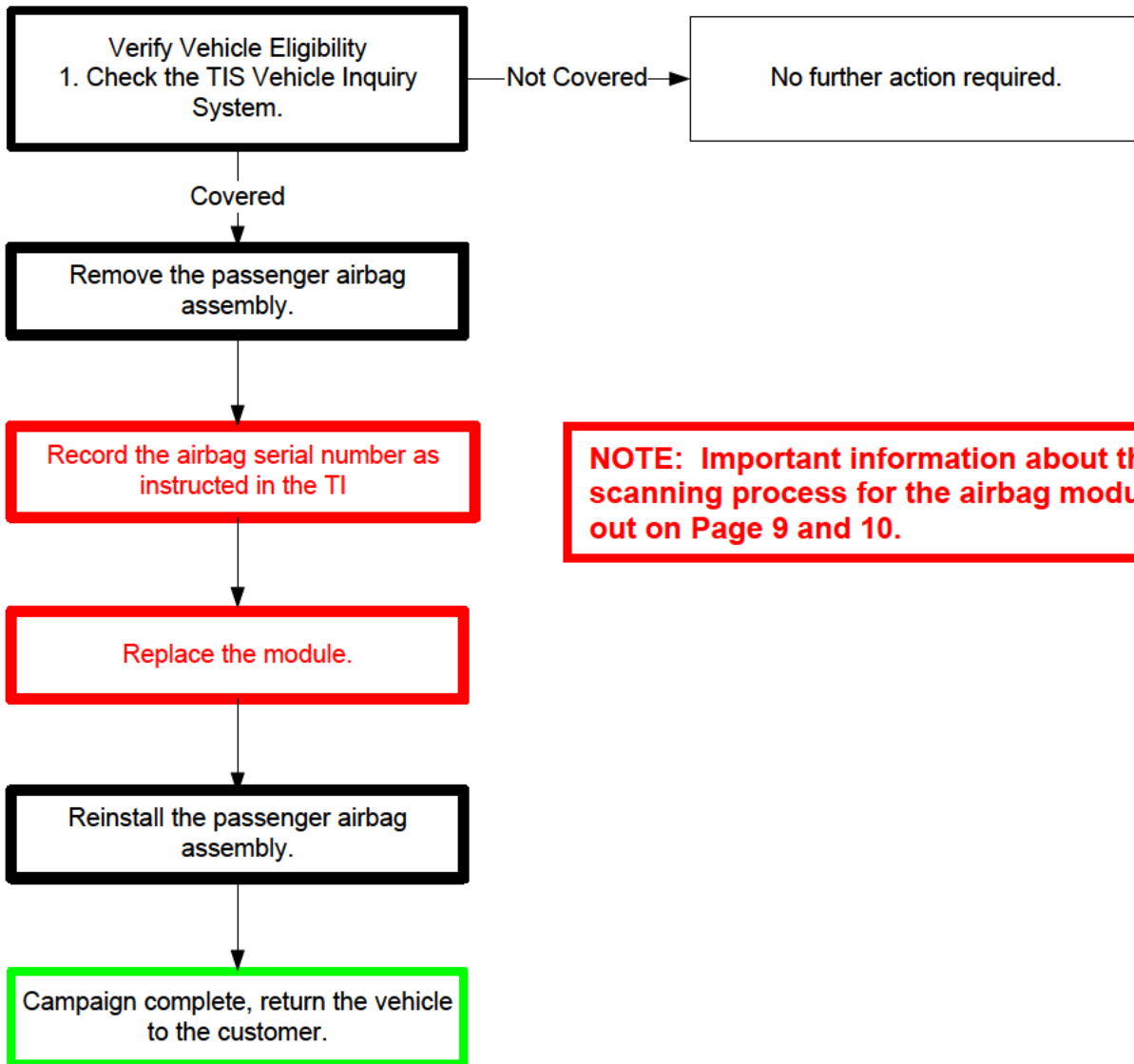

NOTE: Important information about the specific scanning process for the airbag module is called out on Page 9 and 10.

II. BACKGROUND

The subject vehicles are equipped with front passenger airbag inflators which may have been manufactured in such a way as to have a potential for the intrusion of moisture over time. Depending on the circumstances, this could create excessive internal pressure when the airbag is deployed and cause the inflator to rupture. In the event of an inflator rupture, metal fragments could pass through the airbag cushion material, striking the vehicle occupants and potentially resulting in serious injury or death.

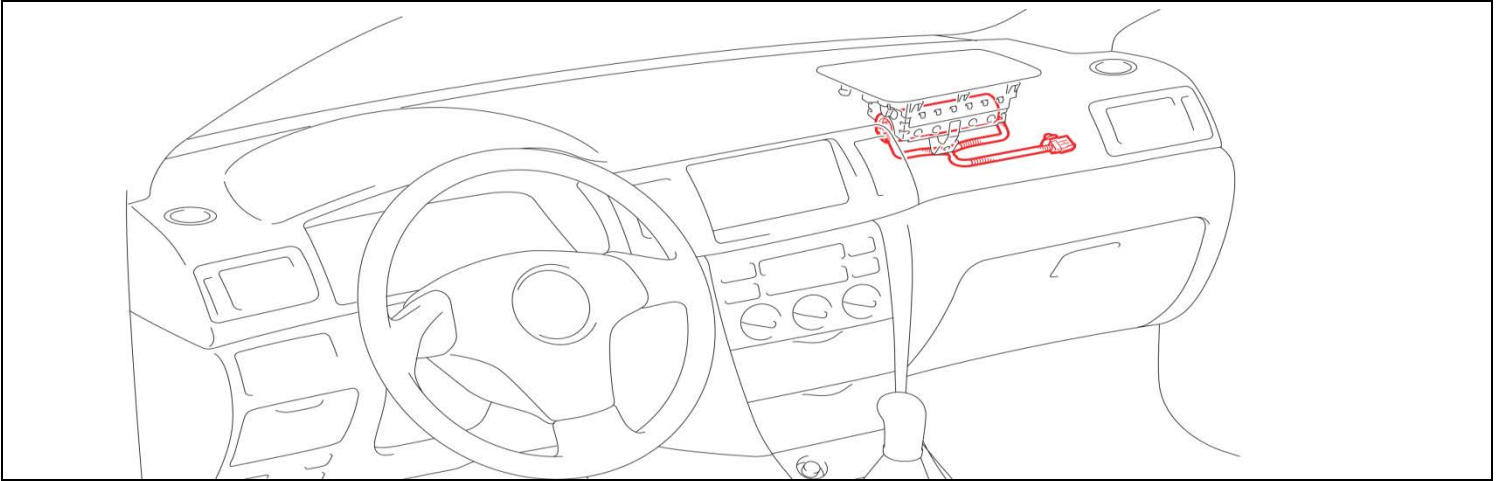

III. IDENTIFICATION OF AFFECTED VEHICLES

- Check the TIS Vehicle Inquiry System to confirm the VIN is involved in this Safety Recall, and that the campaign has not already been completed prior to dealer shipment or by another dealer.
- **TMS warranty will not reimburse dealers for repairs conducted on vehicles that are not affected or were completed by another dealer.**

IV. PREPARATION

A. PARTS

Applicable for: The Continental U.S. 48 States Only

| Model | Part Number | Part Description | Quantity |
|--|-------------|------------------------------|----------|
| 03-04 Matrix | 04005-22601 | Instrument Panel Airbag Kit* | 1 |
| 05-08 Matrix | 04005-22901 | Instrument Panel Airbag Kit* | 1 |
| *The kit above includes the following parts. | | | |
| Airbag Module | | 1 | |
| Matrix | 04005-28112 | IP Wire Harness Kit* | 1 |
| *The kit above includes the following parts. | | | |
| Wire Harness | | 1 | |

Applicable for: Alaska, Hawaii and USTT Locations Only

| Model | Part Number | Part Description | Quantity |
|--|-------------|------------------------------|----------|
| 03-04 Matrix | 04005-22501 | Instrument Panel Airbag Kit* | 1 |
| 05-08 Matrix | 04005-22801 | Instrument Panel Airbag Kit* | 1 |
| *The kit above includes the following parts. | | | |
| Airbag Module | | 1 | |
| Matrix | 04005-28112 | IP Wire Harness Kit* | 1 |
| *The kit above includes the following parts. | | | |
| Wire Harness | | 1 | |

B. TOOLS & EQUIPMENT

- Standard hand tools
- Torque wrench
- Molding remover set
- Techstream

OPTIONAL SST – This is an essential special service tool that the dealership should have. This tool is not mandatory when performing this repair.

| Part Number | Part Name | Quantity |
|----------------|---------------------|----------|
| 09890-47010-01 | Anti-Static Mat Set | 1 |

DSF CAMPAIGN TOOLS – This tool was provided to the dealership for campaign D0F and will be used for campaign DSF. This tool is required when performing this repair.

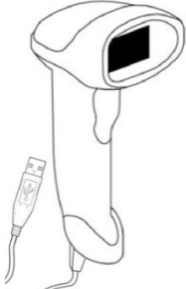
| Image | Name | Quantity |
|---|-----------------|----------|
|  | Barcode Scanner | 1 |

NOTE: This tool **CANNOT** be ordered through the parts or tools system. There is a very limited supply of tools, but if additional tools are needed, contact your regional representative.

V. COMPONENTS

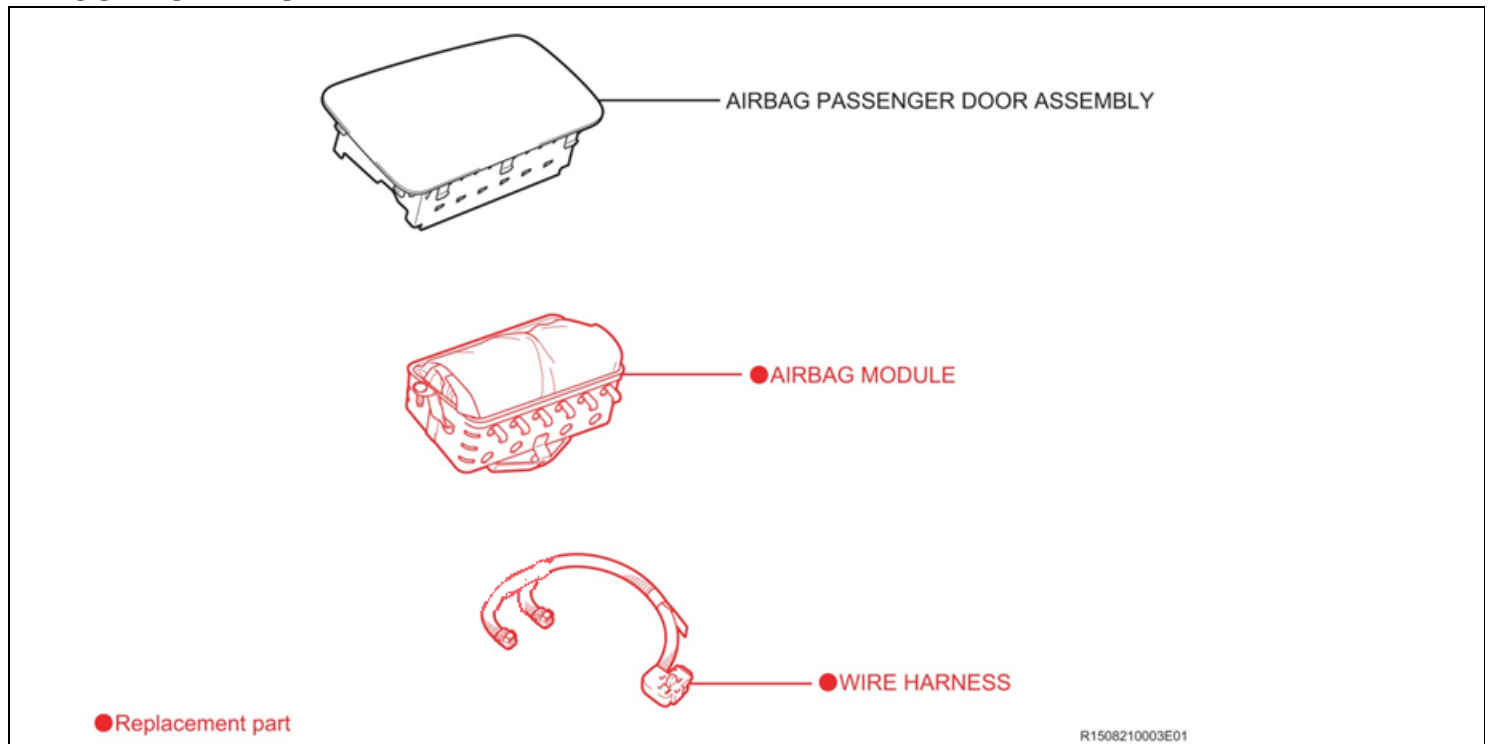

VI. SAFETY PRECAUTIONS

STOP

CRITICAL INFORMATION – READ THOROUGHLY

STOP

Failure to follow these procedures correctly could cause the SRS to unexpectedly deploy during servicing or the SRS may fail to operate correctly when required after reassembly. Confirm all work is performed as described in these instructions.

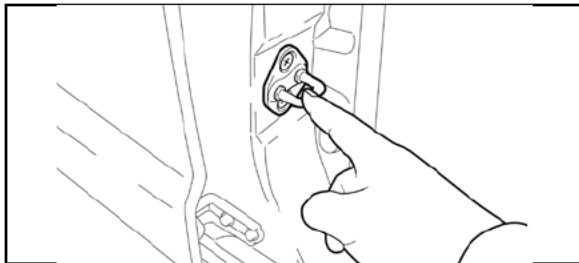

1. ELIMINATE STATIC ELECTRICITY

- a) Before starting work and periodically while working on the vehicle, touch a metallic part of the vehicle to discharge static electricity in the body.

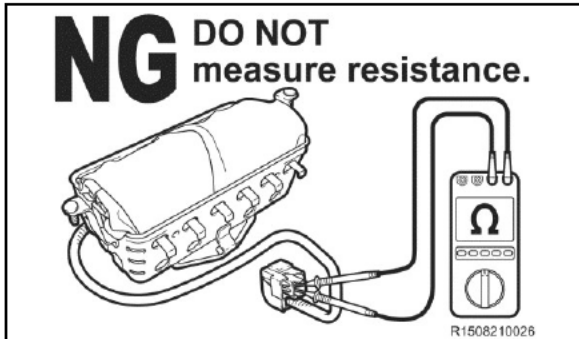

2. DO NOT MEASURE RESISTANCE

- a) **DO NOT** measure resistance of airbag components, this may cause accidental activation.



3. HANDLE THE AIRBAG CAREFULLY

- a) If an inflator is dropped, replace it with a **NEW** inflator.

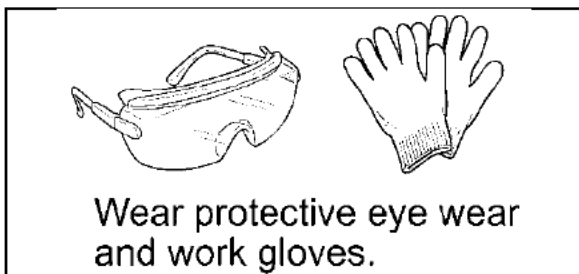

4. WEAR PROTECTIVE EQUIPMENT

- a) Always wear appropriate protective equipment when working on the SRS.

VII. SRS SYSTEM HEALTH CHECK

Confirm the information and press Next

Required Information:

Division: TOYOTA

Model: < Select >

Model/Year:

Engine:

Option:

Optional Information:

VIN:

Memo:

Manual Help <Back Next> Cancel

1. PERFORM A HEALTH CHECK

- Confirm the Techstream is connected to the dealership's internet.
- When launching the Techstream software the VIN **MUST** be entered manually.

NOTE: All letters of the VIN *MUST* be entered in ALL CAPS, or the VIN will need to be reentered when running the diagnostic report.

- Perform a health check.



- The VIN **MUST** be entered manually in ALL CAPS when launching the Techstream software, the VIN **MAY NOT** auto-populate due to vehicle age.
- The serial number recording application will be disabled and the repair cannot be completed if a health check and diagnostic report is not performed and recorded by TMS.

VIII. WORK AREA PREPARATION



CRITICAL INFORMATION – READ THOROUGHLY



The anti-static mat set that is an essential SST may be available at your dealership and is optional to use during inflator replacement. If the anti-static kit is not available, before starting work and periodically while working on the vehicle, touch a metallic part of the vehicle to discharge static electricity in the body.

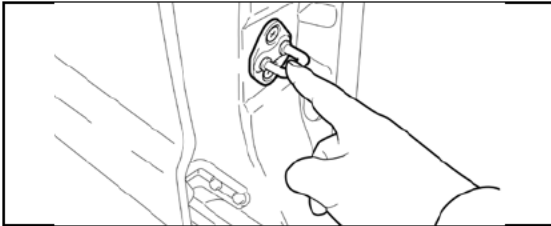

If the anti-static kit is not available, before starting work and periodically while working on the vehicle, touch a metallic part of the vehicle to discharge static electricity in the body.

IX. PASSENGER AIRBAG INFLATOR REPLACEMENT

1. LAUNCH THE SERIAL NUMBER RECORDING APPLICATION



- The **AIRBAG ASSEMBLY** and **NEW MODULE** serial numbers **MUST** be recorded using the barcode scanner (provided at the launch of SSC D0F).
- The barcode scanner application **MUST** be completed on every vehicle. These numbers **MUST** be included on every warranty claim that is submitted for inflator module replacement or the claim may be subject to debit.
- The technician performing the work **MUST** have valid TIS login credentials and an internet connection to perform the inspection and scanning process.

- a) Log in to TIS and input the VIN of the vehicle in the Vehicle Inquiry tab.
- b) Confirm the VIN is applicable and that the campaign has not been completed.
- c) Click on the link to launch the serial number recording application.

Vehicle Identification Number Search

Enter a 17 Digit VIN below to search for applicable information:

VIN:

Vehicle Information

| | | | |
|---|---|---------------------------------------|------------------|
| Division: TOYOTA | Model: Corolla | Grade: CE | Model Year: 2003 |
| Drive Type: 2WD | Body Type: 4Dr. Sedan | Engine Family: 4-cylinder - 1ZZ | Transmission: |
| Date of First Use: | Production Date: 01/18/2002 | Plant Code: Z - FREMONT PLANT - NUMMI | |
| VIN: 1NX-BR32E-000000000 | Standard Equipment: Click here to display | | |
| Exterior Color: 03MS, SANDRIFT METALLIC | Interior Color: FA41, FA41 | Interior Fabric: F, * | |
| Interior Trim Color: FA, * | | | |

Vehicle accessories are not currently available. Try your query again later.

Service Campaign

Campaign Description: Safety Recall D0F Remedy Notice - 2003-2004 Model Year Corolla, Corolla Matrix, Sequoia, and Tundra Vehicles, 2002-2003 Model Year Vehicle Front Passenger Airbag Inflator Module

Completion Status: **Not Completed** [Check applicability for VIN](#)

[Show Documents] E04

- d) Reenter TIS password in the serial number recorder application.

NOTE: The person logged-in to TIS MUST be the person performing the repair.

Front Passenger Airbag Inflator Module - Safety Recall

SSC - DSF

User ID: Suzuki Technician Name: Russell Suzuki

Dealer Code: Dealer Name:

Time: 06/10/2014 02:07 PM PDT Airbag Serial #:

Original Inflator Serial #: Replacement Inflator Serial #:

VIN: 1TDJTFE82C000000000 (2002 M, M)

Mileage*

| Task | Dealer | User | Time | Status |
|--------------------|--------|------|------|-------------|
| Original Inflator | | | | Not Started |
| Inflator # Record | | | | Not Started |
| Terms & Conditions | | | | Not Started |
| New Airbag # | | | | Not Started |

- e) Record the vehicle mileage into the serial number recording application.

NOTE:

- A task status screen will populate next and at other intervals during the repair. This screen will indicate if the module was replaced or in some limited cases that the entire airbag assembly was replaced. Click 'next' to proceed to the next step. This information will be used for record keeping by TMS.
- If this screen indicates that the inflator has already been replaced on this VIN, there is no need to perform the campaign again.

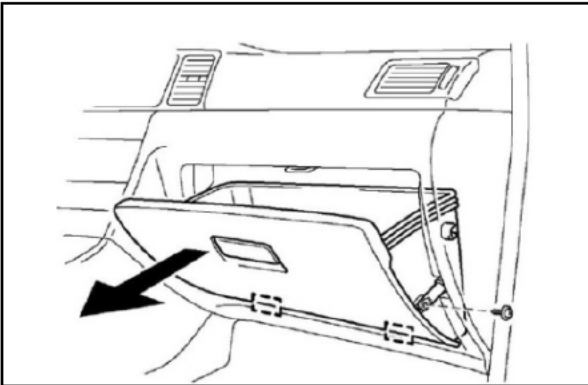

2. REMOVE THE GLOVE BOX

- a) Open the glove box door.
- b) Press in on both sides of the door and swing it down to remove it from the vehicle.

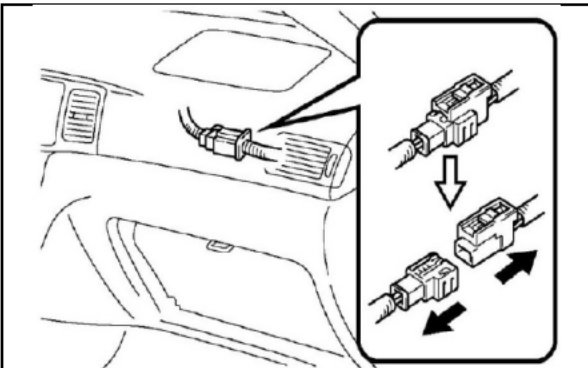

3. REMOVE THE AIRBAG ASSEMBLY

- a) Disconnect the negative battery cable.

STOP

- Wait at least 90 seconds after disconnecting the cable from the negative battery terminal to prevent airbag and seat belt pre-tensioner deployment.
- Follow all precautions as outlined on TIS before servicing the SRS system.

- b) Disconnect the airbag connector.

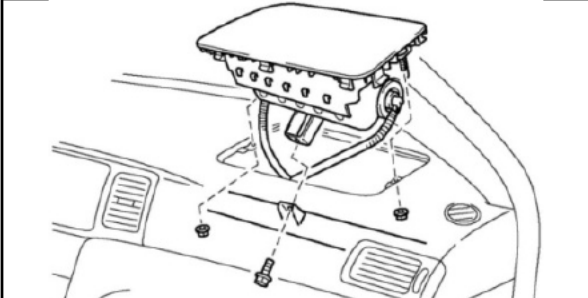

4. REMOVE THE FRONT PASSENGER AIRBAG

- a) Remove the 2 nuts and release the 6 clips.
- b) Remove the airbag assembly.

5. CONNECT THE BARCODE SCANNER

- a) Connect the barcode scanner to the USB port on the Techstream.
- b) The scanner will automatically connect and a beep will be heard when the scanner is ready.

NOTE:

- The scanner was provided for SSC D0F.
- The scanner works best in low light conditions.
- Always hold the scanner directly in front of and parallel to the barcode label.

6. SCAN THE AIRBAG SERIAL NUMBER

- a) Scan the **AIRBAG ASSEMBLY** serial number 2 times.
 - 1) Confirm the cursor is in the first serial number box then scan the serial.
 - 2) Position the cursor in the second serial number box then scan the serial.

NOTE:

- If both serial numbers that are entered do not match, confirm and reenter.
- If the serial number barcode will not scan, it can be entered manually.

AIRBAG SERIAL NUMBER IDENTIFICATION

- The airbag serial number is **ALWAYS** the 12 **DIGITS** located between the asterisks.
- The 3 digits before the asterisk **ARE NOT** part of the serial number, and **SHOULD NOT** be entered or an inaccurate response may be returned.

Airbag Serial Number Label Example



STOP

The **AIRBAG ASSEMBLY** serial number **MUST** be recorded prior to replacement.

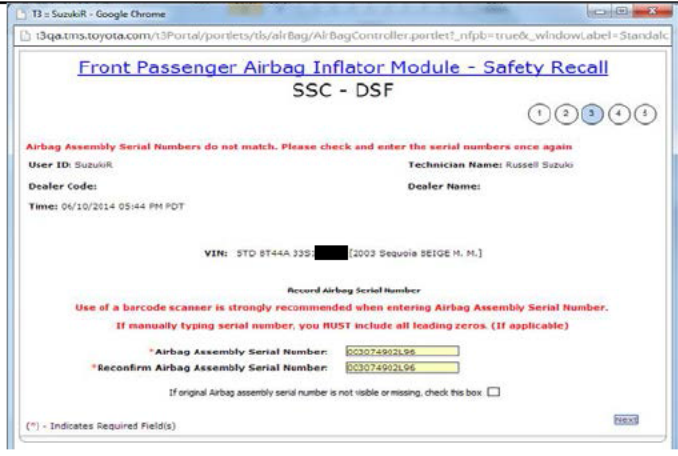
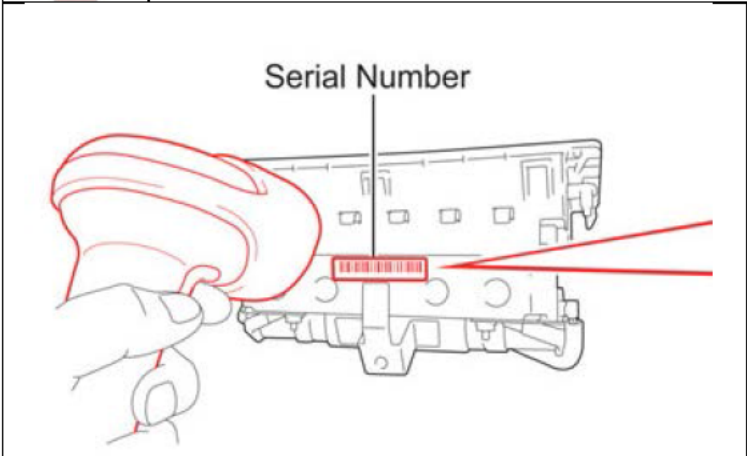

NOTE: If the airbag serial number # is missing or cannot be scanned go to page 12.

b) Click next.

STOP

CRITICAL INFORMATION – READ THOROUGHLY

STOP



- Because this new part is a complete airbag assembly with a different style inflator installed, **you do not need to record the old or new inflator serial numbers.**

Note: The old tube style inflator may still be available. If you have that part you need to refer to the old set of instructions which will require the old and new inflators to be recorded.

- The New 12 digit Airbag Serial number on the side of the assembly will need to be recorded
- To record the new Airbag Serial number, in the scanning application you will need to **check the box indicating the old Inflator serial number is not readable or missing.** This will take you to the screen that allows you to enter the new airbag serial number.
Go to step C on page 10

Remember: You will need to check the box indicating the old inflator serial number is not readable or missing to move to the next screen.

T3 :: Google Chrome
t3qa.tms.toyota.com/t3Portal/portlets/tis/airBag/AirBagController.portlet?...
Front Passenger Airbag Inflator Module - Safety Recall
SSC - E04

User ID: _____
Dealer Code: _____
Time: 03/30/2015 05:17 AM PDT
VIN: 1NX BR32E 142 [REDACTED] 2004 Corolla SUPER WHITE

Technician Name: _____
Dealer Name: _____
Airbag Serial #: *****12

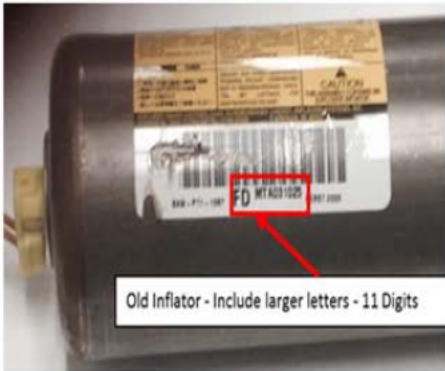
Original Inflator

Old Inflator - Include larger letters - 11 Digits

Replacement Inflator

Replacement Inflator - Include larger letters - 11 Digits

How to Identify the Inflator serial code on the Original and Replacement Inflator can?
The Inflator serial code is an 11 digit code on the Inflator can. It can be found with a bar code on removing the Inflator can from the Airbag Assembly unit.
The first two characters of the Original Inflator Serial code will be from [AA, AB, AJ, FD or JD].
The first two characters of the Replacement Inflator Serial code will be either 'LT' or 'LR'.

Inflator Module replacement IS REQUIRED on all vehicles under the Safety Recall. Follow the technical instructions and acknowledge the following statements.
If manually typing serial number, you MUST include all leading zeros. (If applicable)
Original Inflator Serial #:
If old inflator serial number is not visible or missing, check this box
* Replacement Inflator Serial #:

If you have a concern with the inflator serial numbers, please email quality_compliance@toyota.com with details.

* I agree to complete the safety recall's remaining technical instructions.
 * I agree to perform a vehicle Health Check with Techstream upon completion of the safety recall's technical instructions.

(*) - Indicates Required Field(s)

Back Clear **Submit**

- c) Check the box that the inflator number is missing this will move the program to the next screen.
- d) Confirm agreement by checking the two boxes.
- e) Click Submit.

Scan the New Airbag Assembly Serial Number

- f) Confirm the cursor is in the serial number box
- g) Scan the replacement module serial number
- h) Click next.

Front Passenger Airbag Inflator Module - Safety Recall
SSC - DSF

1 2 3 4 5

User ID: SuzukiR Technician Name: Russell Suzuki
Dealer Code: Dealer Name:
Time: 06/12/2014 03:43 PM PDT

VIN: STD BT44A 335 [2003 Sequoia BEIGE M. M.]

Record Airbag Serial Number
Use of a barcode scanner is strongly recommended when entering Airbag Assembly Serial Number.
If manually typing serial number, you MUST include all leading zeros. (If applicable)

*New Airbag Assembly Serial Number: 003074902L96

(*) - Indicates Required Field(s)

Next

- i) Record the Warranty Authorization # to be included in the warranty claim.

Front Passenger Airbag Inflator Module - Safety Recall
SSC - DSF

1 2 3 4 5

User ID: SuzukiR Technician Name: Russell Suzuki
Dealer Code: Dealer Name:
Time: 06/10/2014 05:13 PM PDT
Original Inflator Serial #: AAEL5110212
Airbag Serial #: *****96
Replacement Inflator Serial #: AAEL5110213

SuzukiR has agreed to the following terms and conditions on 06/10/2014 05:13 PM PDT
 I agree to complete the safety recall's remaining technical instructions.
 I agree to perform a vehicle Health Check with Techstream upon completion of the safety recall's technical instructions.

Russell Suzuki has successfully confirmed completion of Airbag Inflator Module Safety Recall for
VIN - STD BT44A 335157201 [2003 Sequoia BEIGE M. M.]
Warranty Authorization #: b5511e9f
Airbag inflator module was replaced under this safety recall.
Print this page for your records and then click 'Close' to resume working.

Close

- j) Place the old module in the parts box and take it immediately to the parts department.

NOTE:

- Confirm the cursor is in the correct serial number input box before scanning.
- If the serial number barcode will not scan, it can be entered manually.
- If there are any difficulties or concerns with this process, email Quality_compliance@toyota.com with details.

X. MODULE REPLACEMENT

1. WORKING WITH AIRBAG

- a) Carefully place the airbag on the bench inflator side up.

NOTE: Place clean sheet(s) of paper on the bench to protect the airbag.

- b) Avoid standing directly over the inflator.

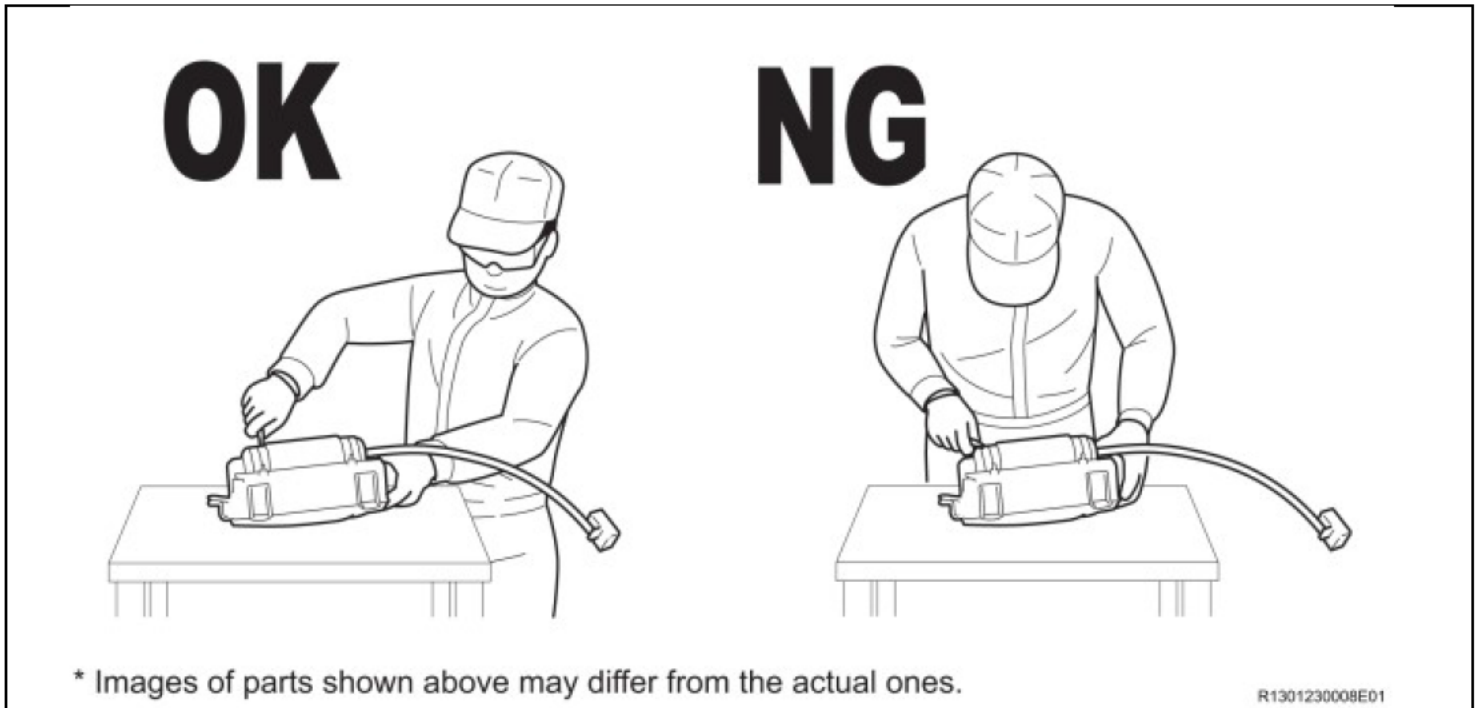

STOP CRITICAL INFORMATION – READ THOROUGHLY STOP



Remember to periodically touch a metallic part of the vehicle to discharge static electricity in the body if the anti-static kit is not being used.

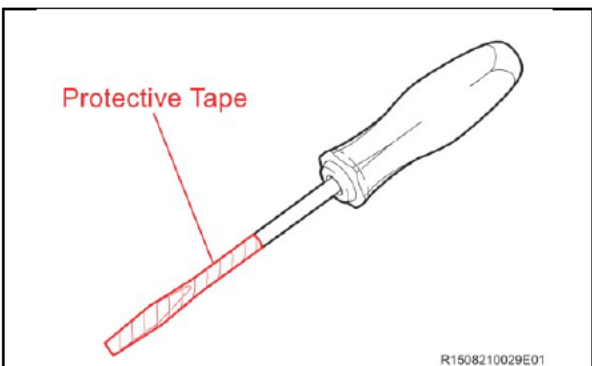

2. TOOL PREPARATION

- a) Wrap a screwdriver with tape.

3. REMOVE THE COVER

- a) Gently insert the screwdriver between the airbag door and module and disengage the claws holding the door to the module. Please refer to the video below.

[VIDEO](#)

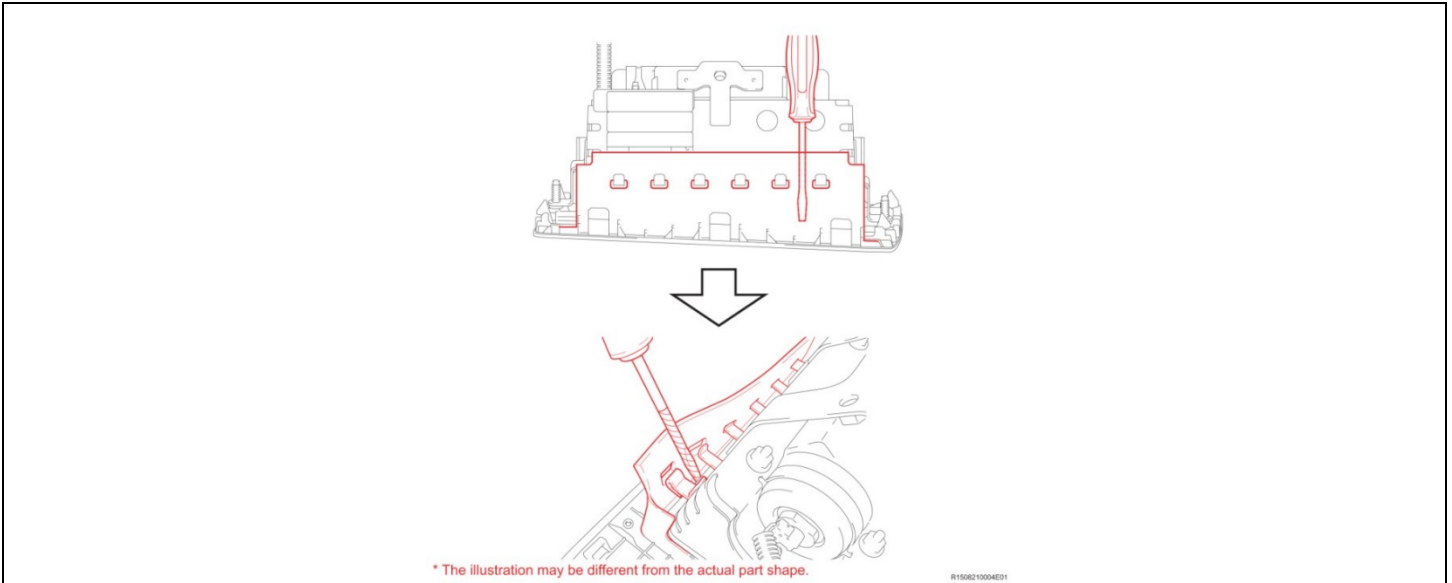

- b) After all the claws have been disengaged separate the module from the door.
- c) Mark the old module so it is not reused.
- d) Inspect the door for damage to the mounting slots.

Take care not to mistake the mounting direction.

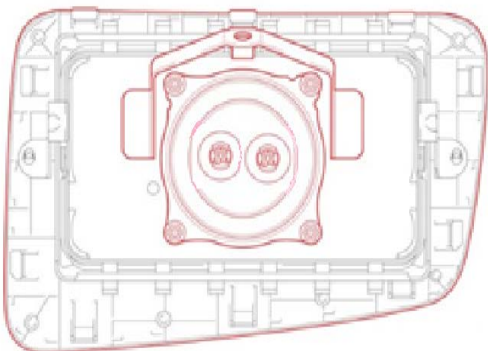

4. INSTALL THE NEW MODULE

- a) Carefully slide the new module into the airbag door.

NOTE: Mounting direction.

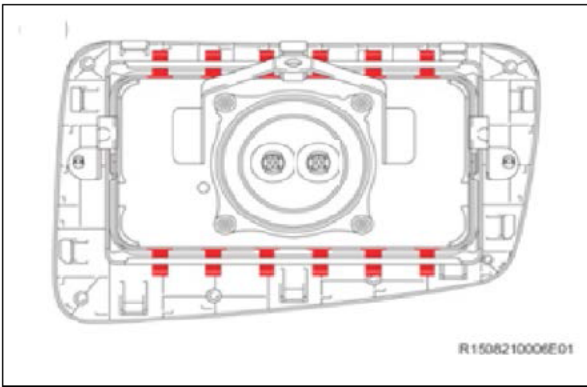

b) Reengage the tangs of the module into the door using the screwdriver with the shaft wrapped in tape.

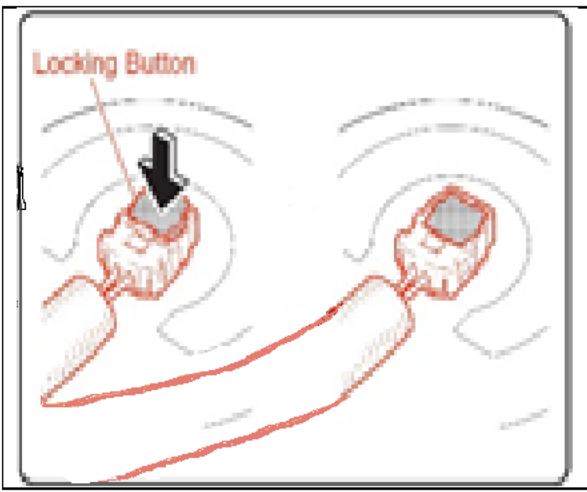

c) Connect the new harness to the new module.
d) Press the lock tab down.

XI. FRONT PASSENGER AIRBAG ASSEMBLY INSTALLATION

1. REINSTALL THE AIRBAG ASSEMBLY

Note: During reinstallation of the airbag assembly, ensure the 12mm bolt and two 10mm nuts securing the airbag assembly to the instrument panel are installed and torqued to the required specification identified on TIS.

a) Refer to TIS for instructions on airbag installation:

Matrix [2003-2005MY](#) [2006MY](#) [2007MY](#) [2008MY](#)

2. RECONNECT THE NEGATIVE BATTERY CABLE

3. PERFORM A HEALTH CHECK AND DIAGNOSTIC REPORT

◀ VERIFY REPAIR QUALITY ▶

- Confirm all precautions are followed to ensure safety during the repair
- Confirm the entire serial number checker application is completed and the warranty authorization # is recorded on **EVERY** vehicle
- Confirm the old module is handled safely and given to the appropriate parts professional for shipment
- Confirm the new harness connector is fully engaged and routed correctly.

If you have any questions regarding this update, please contact your regional representative.

XII. APPENDIX

A. CAMPAIGN DESIGNATION DECODER

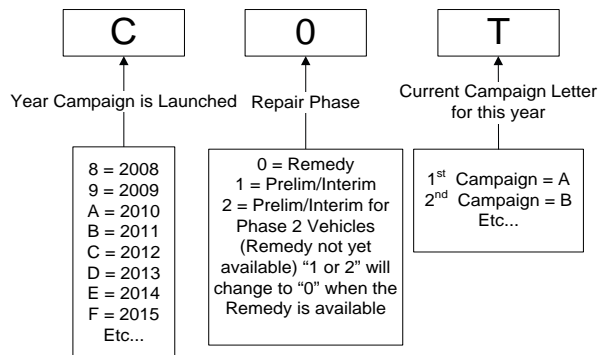

B. CAMPAIGN PARTS DISPOSAL

ALL inflators that are removed from vehicles under this campaign **MUST** be packaged and shipped back to the inflator manufacturer following the manufacturer's instructions. The instructions can be found in the following locations:

- Attached to the dealer letter