

TECHNICAL INSTRUCTIONS
FOR
SAFETY RECALL J0A/J0B/J0C
FRONT PASSENGER AIRBAG INFLATOR MODULE
CERTAIN 2007 – 2012 MY YARIS SEDAN AND
2007 – 2011 MY YARIS HATCHBACK
Updated 01-14-2021

Update 01-14-21

- The scanning application process has been updated

All dealership technicians performing this recall are required to successfully complete the most current version of the E-Learning course “Safety Recall and Service Campaign Essentials”. To ensure that all vehicles have the repair performed correctly; technicians performing this recall repair are required to have successfully completed E-Learning course SC18A (if you had previously completed E-Learning Course SC13B, you do not have to take SC18A), in addition to “Safety Recall and Service Campaign Essentials”, and currently hold at least one of the following certifications levels:

- Toyota Certified (Electrical)
- Toyota Expert (Any Specialty)
- Master
- Master Diagnostic Technicians

Always check which technicians can perform the recall remedy by logging on to <https://www.uotdealerreports.com>. It is the dealership's responsibility to select technicians with the above certification level or greater to perform this repair. Carefully review your resources, the technician skill level, and ability before assigning technicians to this repair. It is important to consider technician days off and vacation schedules to ensure there are properly trained technicians available to perform this repair at all times.

I. OPERATION FLOW CHART

The flow chart is for reference only. **DO NOT** use it in place of the full technical instructions. Follow **ALL** steps as outlined in the full technical instructions to confirm the campaign is completed correctly.

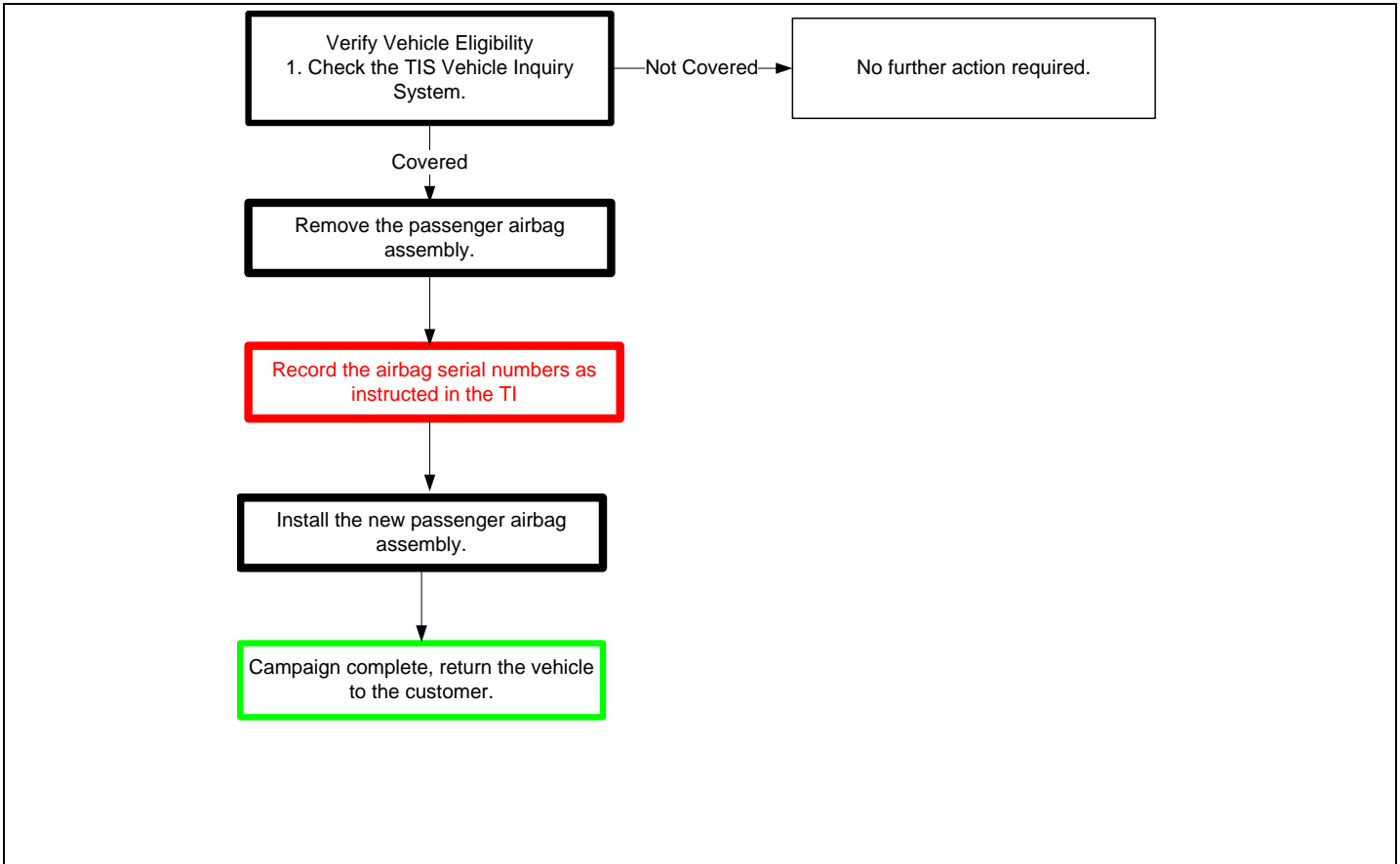

II. BACKGROUND

The subject vehicles are equipped with front passenger airbag inflators produced by Takata. According to Takata, the propellant in these inflators may degrade after prolonged exposure to high absolute humidity and fluctuating high temperatures. Degraded propellant can cause inflator rupture during airbag deployment. In the event of an inflator rupture, metal fragments could pass through the airbag cushion material, striking the vehicle occupants, and result in serious injury or death.

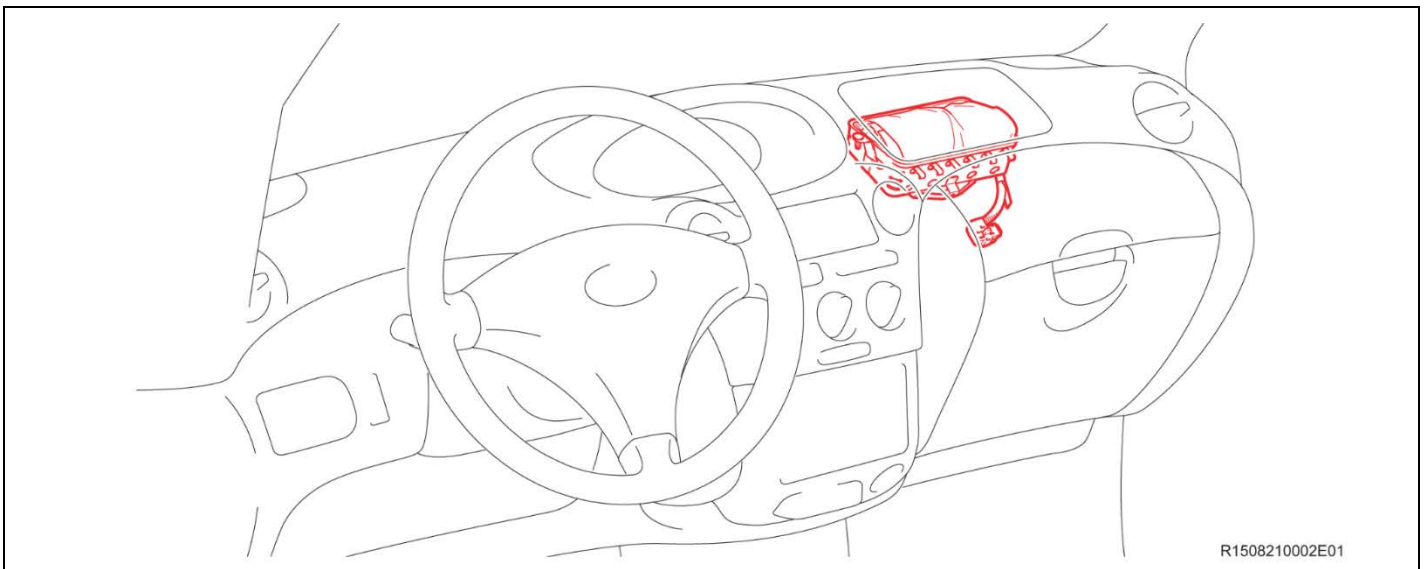

R1508210002E01

III. IDENTIFICATION OF AFFECTED VEHICLES

- Check the TIS Vehicle Inquiry System to confirm the VIN is involved in this Safety Recall, and that the campaign has not already been completed prior to dealer shipment or by another dealer.
- **TMS warranty will not reimburse dealers for repairs conducted on vehicles that are not affected or were completed by another dealer.**

IV. PREPARATION

A. PARTS

Model	Part Number	Part Description	Quantity
Yaris Hatchback	04005-23752	Instrument Panel Airbag Module	1
	04005-28352	Wire Harness	1
	Local source	Tie-wrap	2

Model	Part Number	Part Description	Quantity
Yaris Sedan	04006-39252	Instrument Panel Airbag Module	1
	04005-28352	Wire Harness	1
	Local source	Tie-wrap	2

A. TOOLS & EQUIPMENT

- Standard hand tools
- Torque wrench
- Techstream
- Molding remover set

OPTIONAL SST – This is an essential special service tool that the dealership should have. This tool is not mandatory when performing this repair.

Part Number	Part Name	Quantity
09890-47010-01	Anti-Static Mat Set	1

GOP CAMPAIGN TOOLS – These tools were previously provided to the dealership for campaign D0F and will be used for campaign GOP. These tools are required when performing this repair.

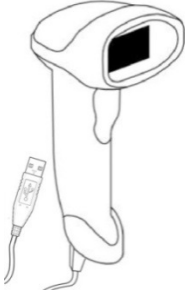
Image	Name	Quantity
	Barcode Scanner	1

NOTE: These tools **CANNOT** be ordered through the parts or tools system. There is a very limited supply of tools, but if additional tools are needed, contact your regional representative.

Non-Desiccated Part Recovery

Dealers should discontinue the installation of the non-desiccated parts listed below for recall, customer pay repairs AND over-the-counter sales (if applicable).

Model	Model Year	Part Number	Part Description
Yaris HB	2006-2011	73960-52030	AIR BAG ASSY, INSTR PNL PASS L/DOOR
Yaris Sedan	2007-2012	73960-52080	

Toyota requires all dealers to return any parts listed above that still remain in dealer inventory by utilizing the Hazmat Part Return Program available. Dealers will be issued a refund for all part returns. This part return program is outlined in *PANT Bulletin 2014-042*.

Important Note:

In order to return the inflator, packages must **NOT** be opened/tampered with.

V. SAFETY PRECAUTIONS



CRITICAL INFORMATION – READ THOROUGHLY



Failure to follow these procedures correctly could cause the SRS to unexpectedly deploy during servicing or the SRS may fail to operate correctly when required after reassembly. Confirm all work is performed as described in these instructions.

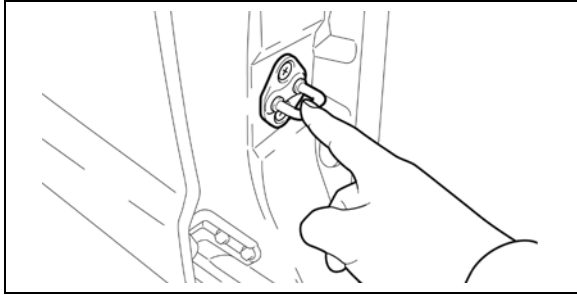

1. ELIMINATE STATIC ELECTRICITY

- a) Before starting work and periodically while working on the vehicle, touch a metallic part of the vehicle to discharge static electricity in the body.

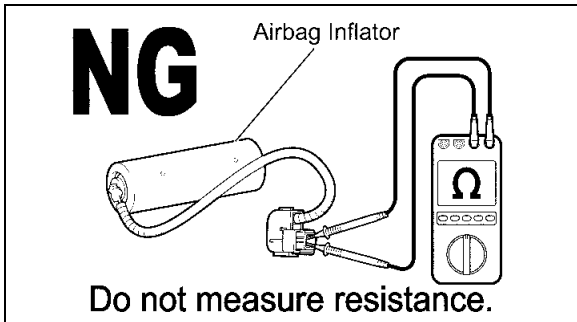

2. DO NOT MEASURE RESISTANCE

- a) **DO NOT** measure resistance of airbag components, this may cause accidental activation.

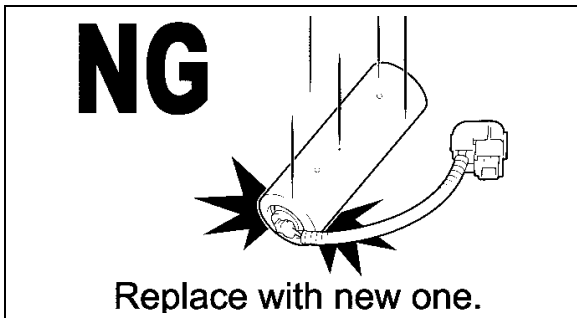

3. HANDLE THE AIRBAG CAREFULLY

- a) If an inflator is dropped, replace it with a **NEW** inflator.

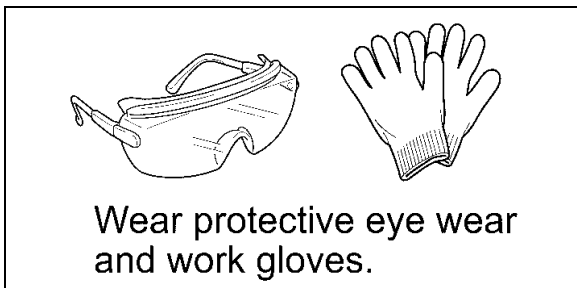

4. WEAR PROTECTIVE EQUIPMENT

- a) Always wear appropriate protective equipment when working on the SRS.

VI. SRS SYSTEM HEALTH CHECK

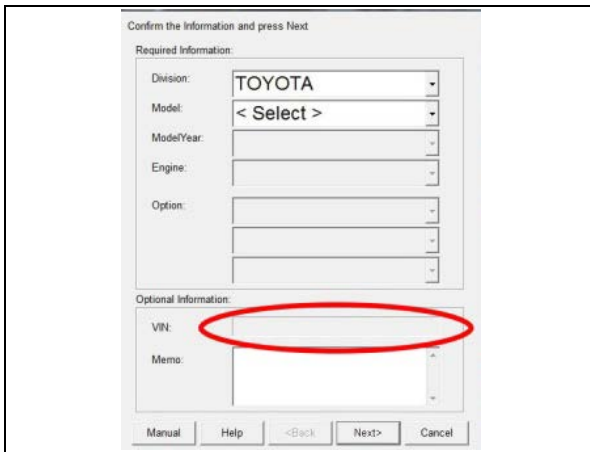

1. PERFORM A HEALTH CHECK

- Confirm the Techstream is connected to the dealership's internet.
- When launching the Techstream software the VIN may need to be entered manually.

NOTE: All letters of the VIN *MUST* be entered in ALL CAPS, or the VIN will need to be reentered when running the diagnostic report.

- Perform a health check.

Note: The VIN may auto populate on the later model year vehicles, if this happens DO NOT change the VIN.

2. RUN A DIAGNOSTIC REPORT

- After the health check has completed, run a diagnostic report by clicking on the link on the health check screen.

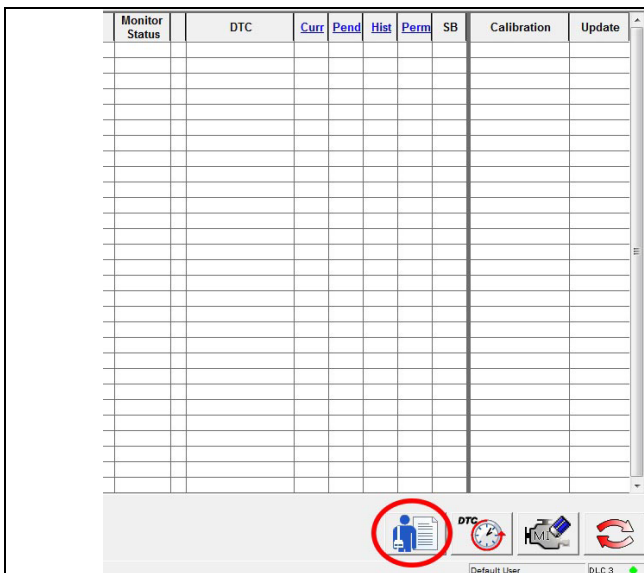

NOTE: If the VIN was not entered in ALL CAPS when Techstream was launched, an error will be displayed and there will be a prompt to reenter the VIN



- Enter the vehicle mileage and repair order information, then click the 'report' button.



- The VIN **MAY NEED** to be entered manually in ALL CAPS when launching the Techstream software. The VIN **MAY NOT** auto-populate on vehicles prior to the 2006 MY.
- A health check and diagnostic report with VIN **MUST** be performed within the last 36 hours and recorded by TMS. If the diagnostic report is not run, the healthcheck will not be recognized by TMS.
- The serial number recording application will be disabled and the repair cannot be completed if a health check and diagnostic report is not performed and recorded by TMS.
- This campaign only covers the replacement of the passenger airbag module. **NO** other SRS components are covered under this campaign.

VII. PASSENGER AIRBAG MODULE REPLACEMENT

COMPONENTS

Hatchback

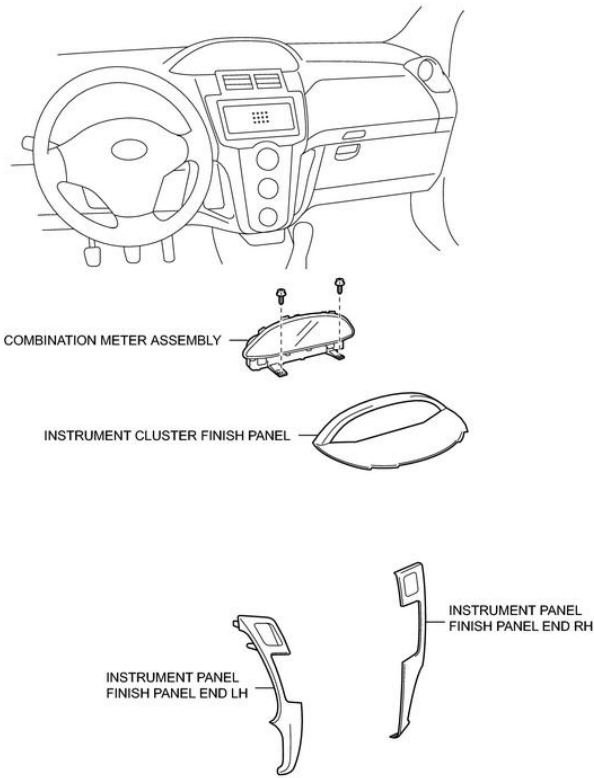

Sedan

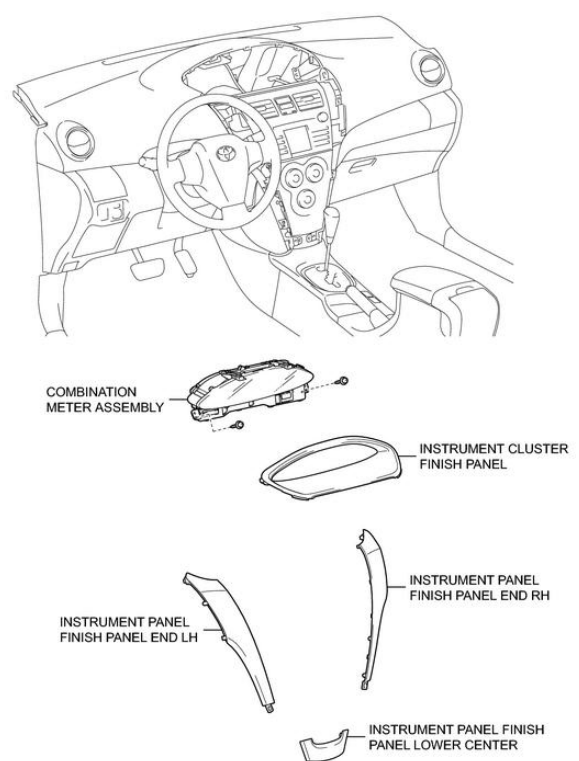

w/ Curtain Shield Airbag:

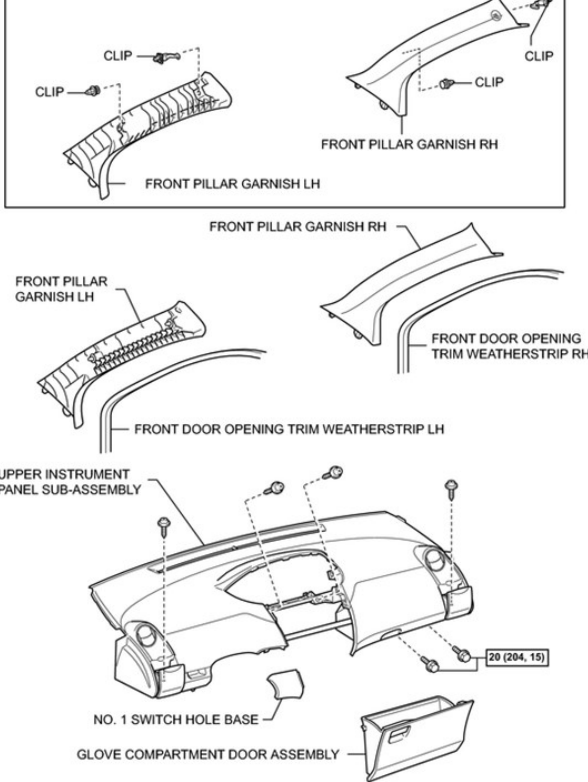

N*m (kgf*cm, ft.*lbf) : Specified torque

w/ Curtain Shield Airbag:

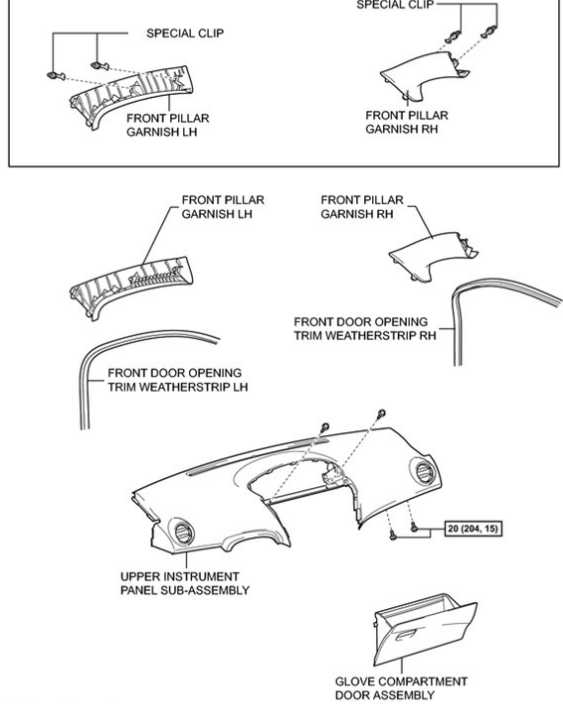

N*m (kgf*cm, ft.*lbf) : Specified torque

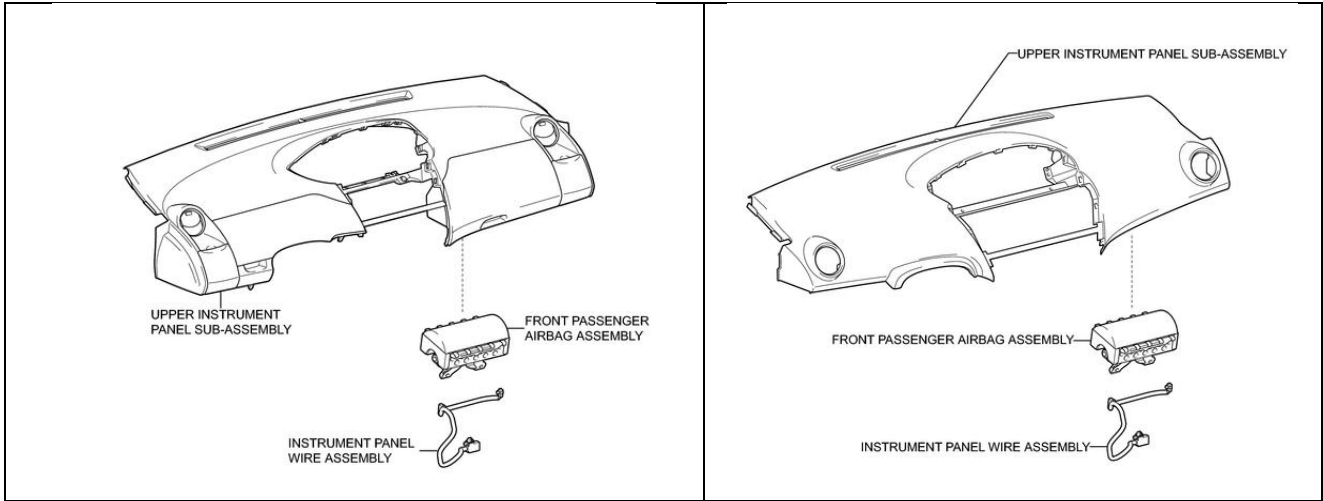

1. REMOVE THE AIRBAG MODULE

a) Refer to TIS for instructions on airbag removal:

Sedan [2007MY](#) [2008MY](#) [2009MY](#) [2010MY](#) [2011MY](#) [2012MY](#)

Hatchback [2007MY](#) [2008MY](#) [2009MY](#) [2010MY](#) [2011MY](#)



- Wait at least 90 seconds after disconnecting the cable from the negative battery terminal to prevent airbag and seat belt pre-tensioner deployment.
- Follow all precautions as outlined on TIS before servicing the SRS system.

2. LAUNCH THE SERIAL NUMBER RECORDING APPLICATION



- The AIRBAG MODULE serial number **MUST** be recorded using the barcode scanner (provided at the launch of SSC D0F).
- The barcode scanner application **MUST** be completed on every vehicle. These numbers **MUST** be included on every warranty claim that is submitted for module replacement or the claim may be subject to debit.
- The technician performing the work **MUST** have valid TIS login credentials and an internet connection to perform the inspection and scanning process.

- a) Log in to TIS and input the VIN of the vehicle in the Vehicle Inquiry tab.
- b) Confirm the VIN is applicable and that the campaign has not been completed.
- c) Click on the link to be sent to the scanning application site.
- d) You can also log into the scanning site via the URL below

Log into the website via the URL below
<https://takata-scan-app.imagespm.info/>

User ID: Dealer Code
First time login password: xxxxx

The screenshot displays the Toyota TIS Vehicle Inquiry interface. At the top, navigation tabs include Home, TIS, TAS, PRS, and QAT. The 'Vehicle Inquiry' tab is active, showing a 'Vehicle Identification Number Search' section with a text input field containing the VIN '1NX-BR32E-000000000' and 'Clear' and 'Lookup' buttons. Below this is the 'Vehicle Information' section, which lists details such as Division (TOYOTA), Model (Corolla), Grade (CE), Model Year (2003), Drive Type (2WD), Body Type (4Dr. Sedan), Engine Family (4-cylinder - 1ZZ), Transmission, Date of First Use, Production Date (01/18/2002), Plant Code (Z - FREMONT PLANT - NUMMI), VIN (1NX-BR32E-000000000), and Standard Equipment (Click here to display). It also shows Exterior Color (03M5, SANDRIFT METALLIC), Interior Color (FA41, FA41), Interior Trim Color (FA, *), and Interior Fabric (F, *). A note states 'Vehicle accessories are not currently available. Try your query again later.' Below the vehicle information are tabs for Campaign, Service History, Warranty, DTC History, and Diagnostic Report. The 'Service Campaign' section is expanded, showing a 'Campaign Description' and a 'Completion Status' of 'Not Completed'. A link to 'check applicability for VIN' is circled in red, with a red 'c)' next to it. Another red circle is around the 'Completion Status' text, with a red 'b)' next to it. A red 'a)' is placed above the VIN search input field. The footer of the page includes '© 2013 Toyota Motor Sales, Inc.' and links for Feedback, Privacy, and Legal.

Login

Complete all required (*) fields below.

*** User ID (enter your 5-digit dealer code, or 6-digit for Canadian dealers eg. Cnnnnn format):**

*** Password:**

Login

[Forgot Password?](#)

Technician Information

Please provide information below before searching for VIN.

Technician Name:

SPIN ID (12 digit code):

Search

a) Enter your name and SPIN ID into the site

Enter VIN

Enter the 17-digit Vehicle Identification Number to begin the search for this campaign.

VIN:

Mileage on Vehicle:

Search

b) Enter the VIN and vehicle mileage into the site

3. CONNECT THE BARCODE SCANNER

- Connect the barcode scanner to the USB port on the Techstream.
- The scanner will automatically connect and a beep will be heard when the scanner is ready.

NOTE:

- **The scanner was provided for SSC DLC.**
- **The barcode scanner works best in low light conditions.**
- **Always hold the scanner directly in front of and parallel to the barcode label.**

4. SCAN THE AIRBAG SERIAL NUMBER

ATTENTION: This information is **CRITICAL**

- a) Scan the **AIRBAG ASSEMBLY** serial number 2 times.
 - 1) Confirm that the cursor is in the first serial number box and scan the bar code.
 - 2) Position the cursor in the second serial number box and rescan the bar code.
- b) Click next.

NOTE:

- If the serial numbers do not match, confirm and reenter.
- If the serial number barcode will not scan, it can be entered manually.

AIRBAG SERIAL NUMBER IDENTIFICATION

- The airbag serial number is **ALWAYS** the 12 **DIGITS** located between the asterisks.
- The 3 digits before the asterisk **ARE NOT** part of the serial number, and **SHOULD NOT** be entered or an inaccurate response may be returned.

Airbag Serial Number Label Example



The **AIRBAG ASSEMBLY** serial number **MUST** be recorded prior to replacement.

ORIGINAL Airbag Assembly Serial Number

Scan or enter the **original** Airbag Assembly serial number into the website.

VIN:
Model / Campaign:

* Serial Number of *Original Airbag Assembly*:

* Re-confirm the Serial Number of *Original Airbag Assembly*:

Check if the airbag serial number is missing or not visible, or if installing a new airbag assembly

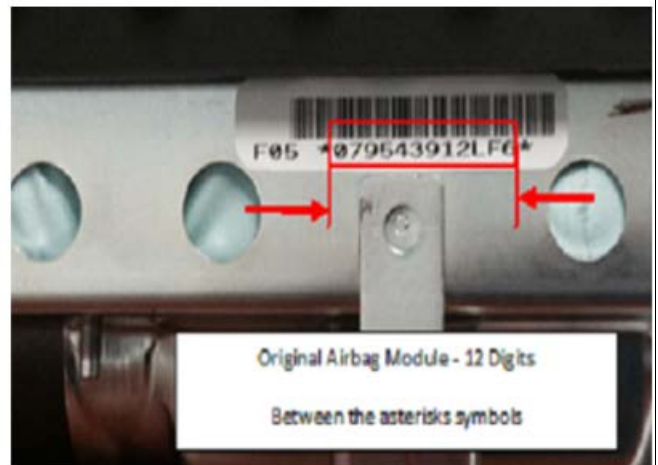

c) Scan the **NEW** Airbag barcode in the Serial Number Recording Application.



Takata Scan App

TMS Test Dealership

[Search Another VIN](#) | [Print Screen](#) | [Log Out](#)

NEW Serial Number

Scan or enter the **new** Airbag Assembly Serial Number into the website.

VIN:

* Serial Number of New Airbag Assembly:

* Re-confirm the Serial Number of New Airbag Assembly:

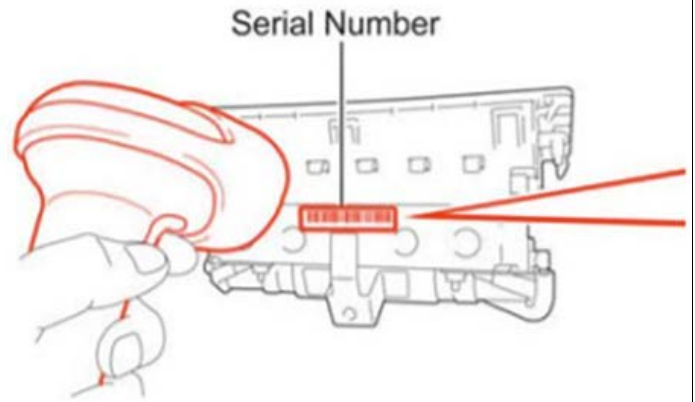

The new **AIRBAG ASSEMBLY** serial number **MUST** be recorded prior to reinstallation to track the airbag assembly to the vehicle.

d) Record the Warranty Authorization # to be included in the warranty claim.

Takata Scan App (TEST v2) Final Results

You can [Print Screen](#) or [Search Another VIN](#).

Results:	Inflator Replacement Required
Warranty Authorization Number:	77515K46 <i>This number is required for the warranty claim. Print and save this screen for your records</i>
VIN:	2T1BR32E57C810829
Vehicle:	2007 Corolla
Campaign:	E04
Original Airbag Serial:	123456789K12
Replacement Airbag Serial:	
Original Inflator Serial:	W0123456789
Replacement Inflator Serial:	W0123456789
Scan Date:	12/22/2020 08:47AM (mm/dd/yyyy)

e) Confirm agreement by checking the two boxes.

f) Place the old airbag in the parts box and return it to the parts department.

NOTE:

- **Keep all shipping paperwork with the box that it came in.**
- **Confirm the cursor is in the correct serial number input box before scanning.**
- **If the serial number barcode will not scan, it can be entered manually.**
- **If there are any difficulties or concerns with this process, email quality_compliance@toyota.com with details.**

VIII. FRONT PASSENGER AIRBAG REINSTALLATION

1. REINSTALL THE AIRBAG



- a) Install the new harness onto the new airbag by plugging in the two connectors.

NOTE: Match the color of the harness connector to that of the airbag. Ensure that the connectors are fully seated.



- b) Engage the secondary locks.

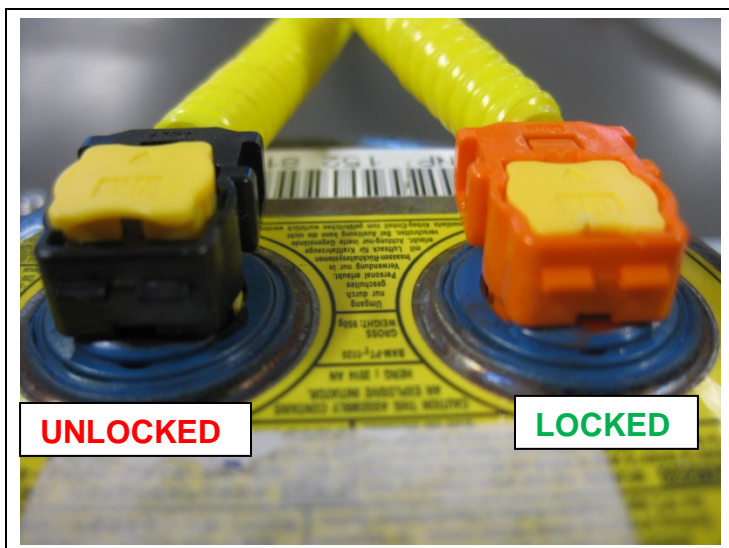

NOTE: Ensure the secondary locks are fully engaged.

c) Refer to TIS for instructions on airbag installation:

Sedan [2007MY](#) [2008MY](#) [2009MY](#) [2010MY](#) [2011MY](#) [2012MY](#)

Hatchback [2007MY](#) [2008MY](#) [2009MY](#) [2010MY](#) [2011MY](#)

After the upper instrument panel has been installed secure the new airbag adaptor harness as shown.

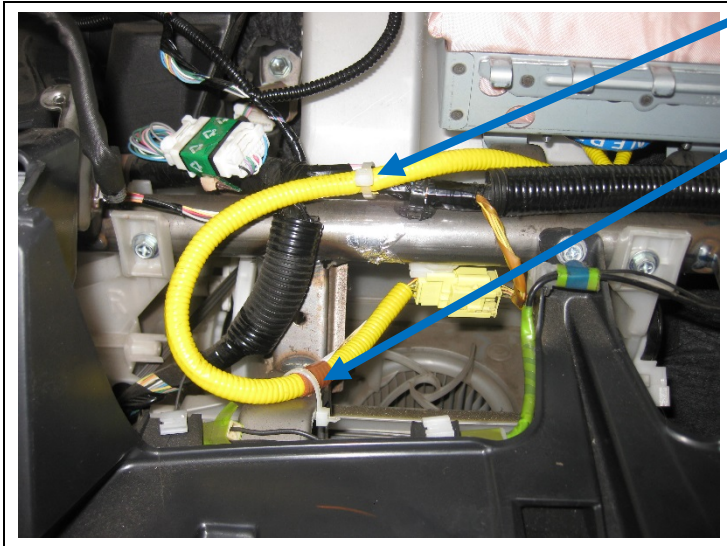

Secure the adaptor harness to the dash harness.

Also secure the adaptor harness to the dash bracket.

NOTE: The upper instrument panel has been removed for clarity. Both areas can be accessed through the opening for the glove box door and/or the opening for the combination meter.

Check that the adaptor harness has the proper clearances and is not strained.

2. RECONNECT THE NEGATIVE BATTERY CABLE

- a) Reconnect the negative battery cable.
- b) Perform any needed system initializations.

3. PERFORM A HEALTH CHECK AND DIAGNOSTIC REPORT

◀ VERIFY REPAIR QUALITY ▶

- Confirm all precautions are followed to ensure safety during the repair
- Confirm the entire serial number checker application is completed and the warranty authorization # is recorded on *EVERY* vehicle
- Confirm the old module is handled safely and given to the appropriate parts professional for shipment
- Confirm the airbag harness connector is fully engaged.

If you have any questions regarding this update, please contact your regional representative.

IX APPENDIX

A. CAMPAIGN DESIGNATION DECODER

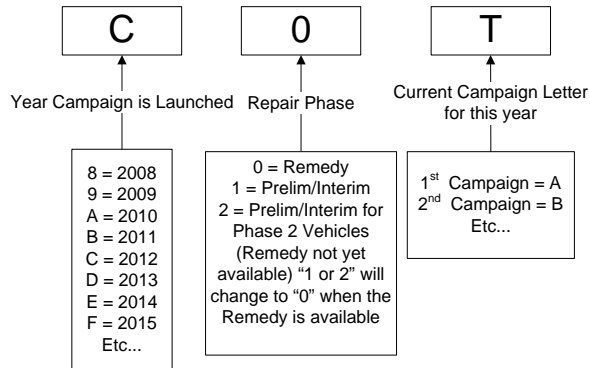

B. CAMPAIGN PARTS DISPOSAL

ALL inflators that are removed from vehicles under this campaign **MUST** be packaged and shipped back to the inflator manufacturer following the manufacturer's instructions. The instructions can be found in the following locations:

- Attached to the dealer letter
- Included in the parts box
- On the laminated aid that was provided at the launch of the campaign