

IMPORTANT UPDATE

TECHNICAL INSTRUCTIONS FOR SAFETY RECALL G0R FRONT PASSENGER AIRBAG INFLATOR MODULE CERTAIN 2010 MY 4RUNNER

UPDATE 9-5-18

Update 09-5-18

- The parts section has been updated

Update 07-17-18

- The Technician Certification Requirements have changed

Update 4-18-18

- The parts section has been updated

All dealership technicians performing this recall are required to successfully complete the most current version of the E-Learning course "Safety Recall and Service Campaign Essentials". To ensure that all vehicles have the repair performed correctly; technicians performing this recall repair are required to have successfully completed E-Learning course SC18A (if you had previously completed E-Learning Course SC13B, you do not have to take SC18A), in addition to "Safety Recall and Service Campaign Essentials", and currently hold at least one of the following certifications levels:

- Toyota Certified (Electrical)
- Toyota Expert (Any Specialty)
- Master
- Master Diagnostic Technicians

Always check which technicians can perform the recall remedy by logging on to <https://www.uotdealerreports.com>. It is the dealership's responsibility to select technicians with the above certification level or greater to perform this repair. Carefully review your resources, the technician skill level, and ability before assigning technicians to this repair. It is important to consider technician days off and vacation schedules to ensure there are properly trained technicians available to perform this repair at all times.

I. OPERATION FLOW CHART

The flow chart is for reference only. **DO NOT** use it in place of the full technical instructions. Follow **ALL** steps as outlined in the full technical instructions to confirm the campaign is completed correctly.

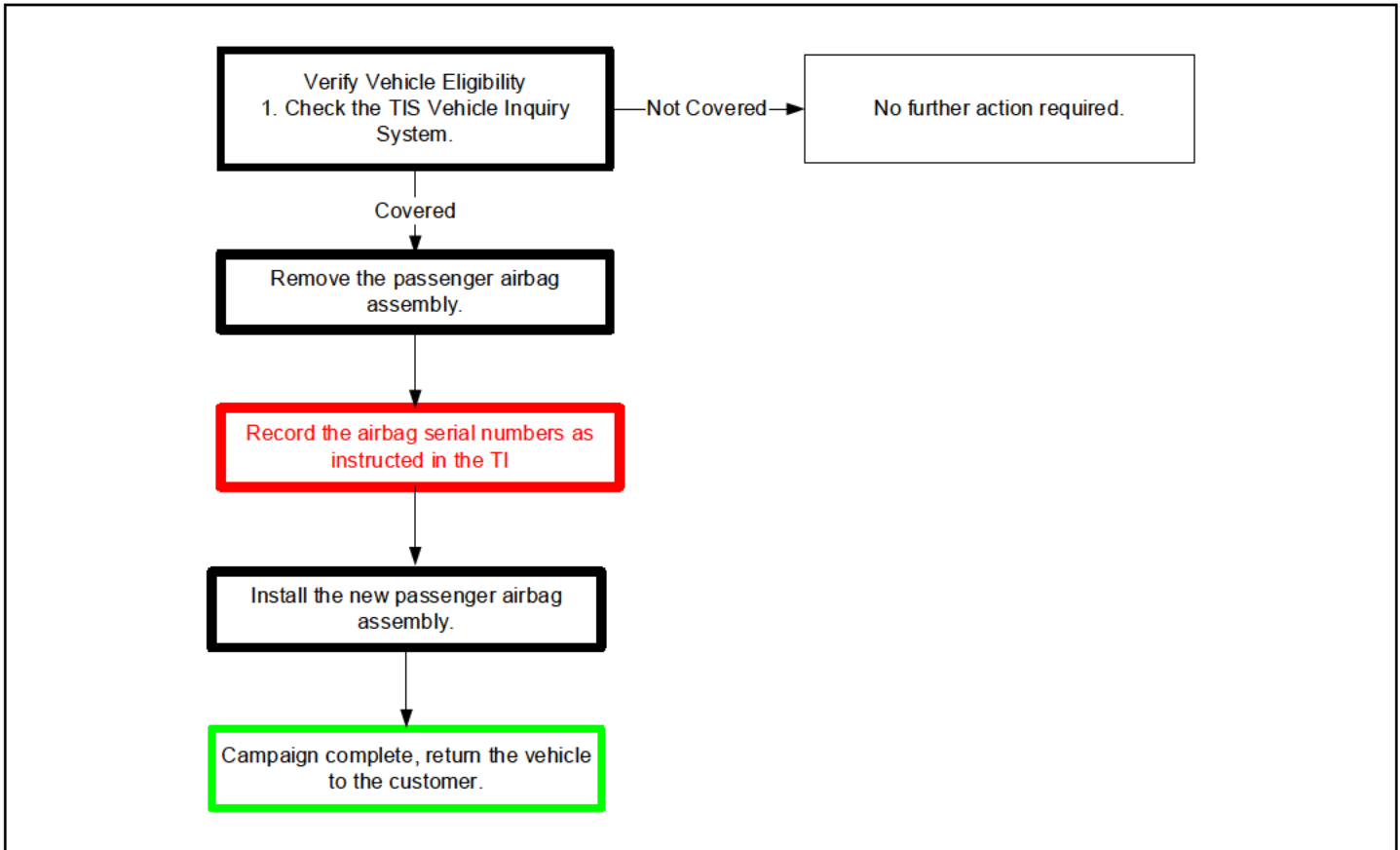

II. BACKGROUND

The subject vehicles are equipped with front passenger airbag inflators produced by Takata. According to Takata, the propellant in these inflators may degrade after prolonged exposure to high absolute humidity and fluctuating high temperatures. Degraded propellant can cause inflator rupture during airbag deployment. In the event of an inflator rupture, metal fragments could pass through the airbag cushion material, striking the vehicle occupants, and result in serious injury or death.

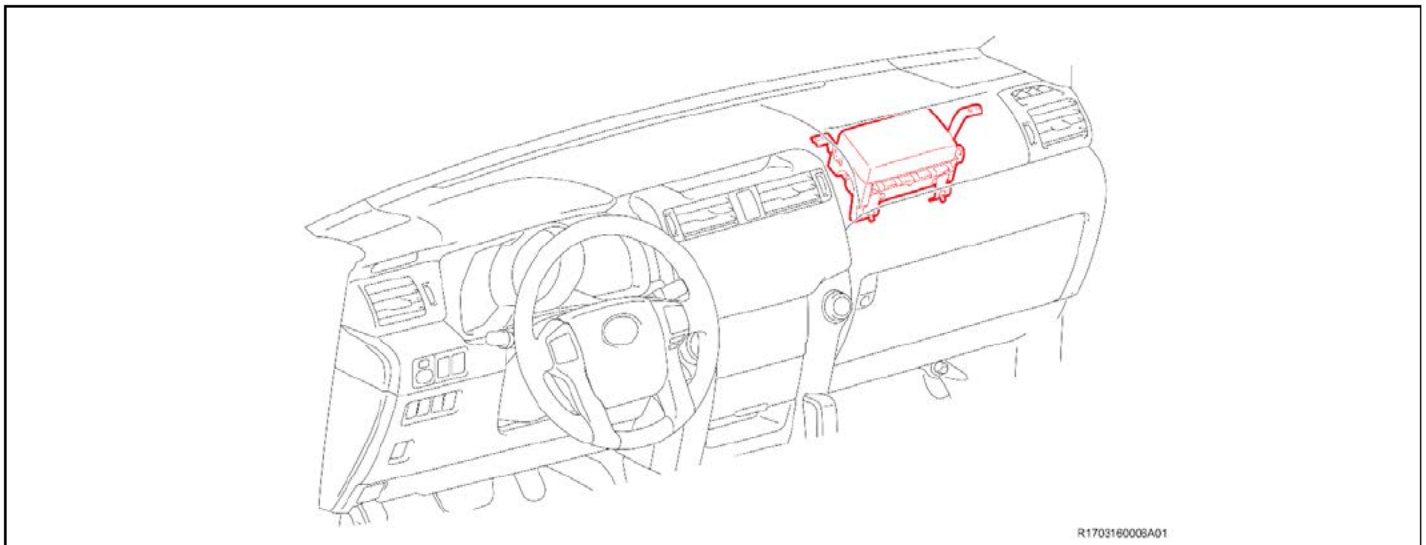

III. IDENTIFICATION OF AFFECTED VEHICLES

- Check the TIS Vehicle Inquiry System to confirm the VIN is involved in this Safety Recall, and that the campaign has not already been completed prior to dealer shipment or by another dealer.
- **TMS warranty will not reimburse dealers for repairs conducted on vehicles that are not affected or were completed by another dealer.**

IV. PREPARATION

A. PARTS

<u>Model/Model Year</u>	<u>Part Number</u>	<u>Part Description</u>	<u>Quantity</u>
2010 4Runner	**04007-58135	Instrument Panel Airbag Module	1
	62220-35030-B0 or 04007-1U135-B0 (Either part number may be used. They are interchangeable) - Light Gray Interior Or 62220-35030-E0 or 04007-1U135-E0 (Either part number may be used. They are interchangeable) - Sand Beige Interior	A-Pillar Garnish	1

****Note:** 04007-14335 is no longer available to order from your facing PDC. This part number is still valid for the repair, however. If you have remaining inventory at your dealer, please continue to use in conjunction with the above A-Pillar garnishes (if required) when repairing 4Runner vehicles until your inventory has been depleted. Once gone, start using 04007-58135 for the repair.

Non-Desiccated Part Recovery

Dealers should discontinue the installation of the non-desiccated parts listed below for recall, customer pay repairs AND over-the-counter sales (if applicable).

Model	Model Year	Part Number	Part Description
4Runner	2010-2013	73960-35080 73960-35081	AIR BAG ASSY, INSTR PNL PASS

Toyota requires all dealers to return any parts listed above that still remain in dealer inventory by utilizing the Hazmat Part Return Program available. Dealers will be issued a refund for all part returns. This part return program is outlined in *PANT Bulletin 2014-042*.

Important Note:

In order to return the inflator, packages must **NOT** be opened/tampered with.

A. TOOLS & EQUIPMENT

- Standard hand tools
- Torque wrench
- Techstream
- Molding remover set

G0P/G0R/H0A CAMPAIGN TOOLS – These tools are required when performing this repair.

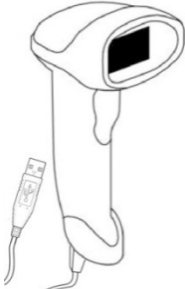
Image	Name	Quantity
	Barcode Scanner (The scanner distributed for F0J can read bar and QR codes)	1

NOTE: This scanner CANNOT be ordered through the parts or tools system. If additional tools are needed, they can be sourced locally.

SST –These are essential service tools that the dealership should have.

Part Number	Part Name	Quantity
09950-50013	Puller C Set *	1
* The set above includes the following tools.		
Part Number	Part Name	Quantity
09951-05010	Hanger 150	1
09952-05010	Slide Arm	2
09953-05020	Center Bolt 150	1
09954-05070	Claw No. 7	2

V. SAFETY PRECAUTIONS



CRITICAL INFORMATION – READ THOROUGHLY



Failure to follow these procedures correctly could cause the SRS to unexpectedly deploy during servicing or the SRS may fail to operate correctly when required after reassembly. Confirm all work is performed as described in these instructions.

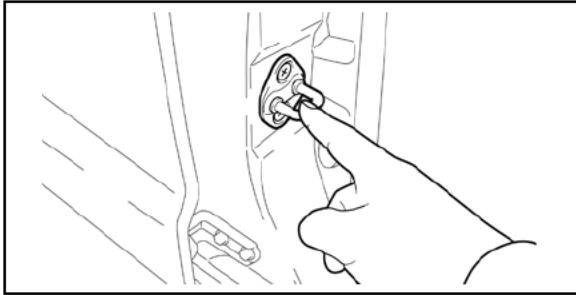

1. ELIMINATE STATIC ELECTRICITY

- a) Before starting work and periodically while working on the vehicle, touch a metallic part of the vehicle to discharge static electricity in the body.



2. DO NOT MEASURE RESISTANCE

- a) **DO NOT** measure resistance of airbag components, this may cause accidental activation.

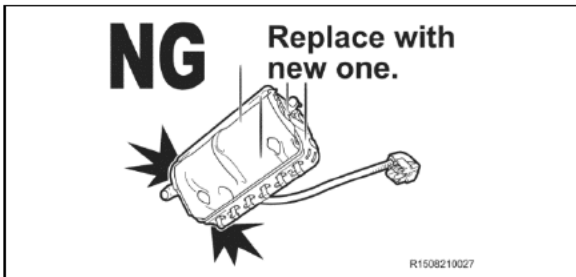

3. HANDLE THE AIRBAG CAREFULLY

- a) If an airbag is dropped, replace it with a **NEW** one.

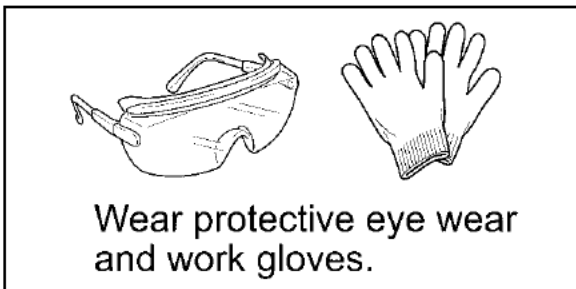

4. WEAR PROTECTIVE EQUIPMENT

- a) Always wear appropriate protective equipment when working on the SRS.

VII. PASSENGER AIRBAG MODULE REPLACEMENT

CAUTION-PLASTIC RETAINING CLIPS ARE FRAGILE. REMOVE WITH CARE

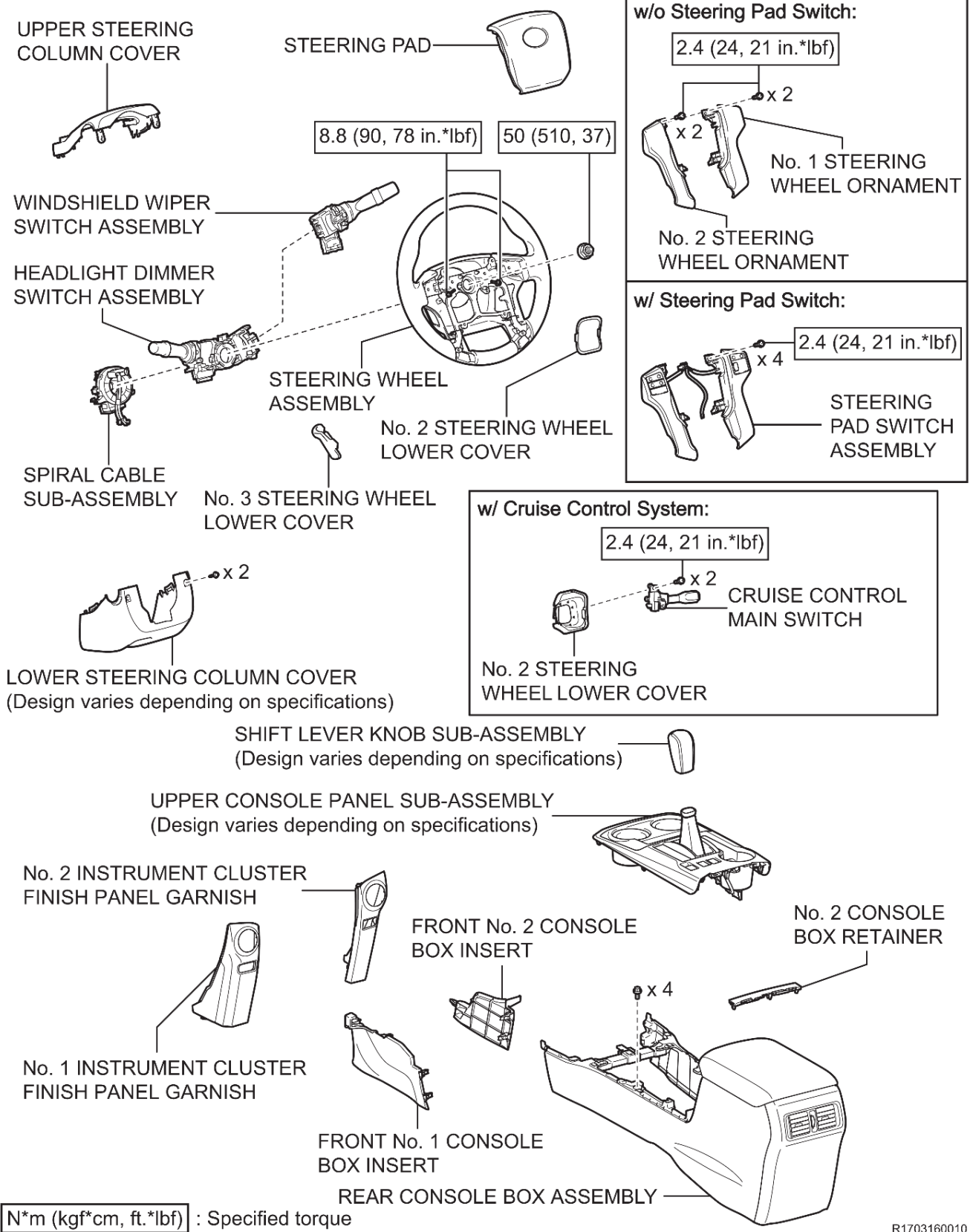

R1703160010

FRONT PILLAR
GARNISH RH

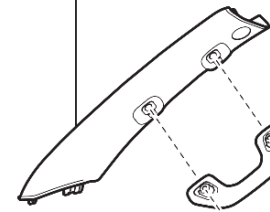

FRONT DOOR OPENING TRIM
WEATHERSTRIP RH

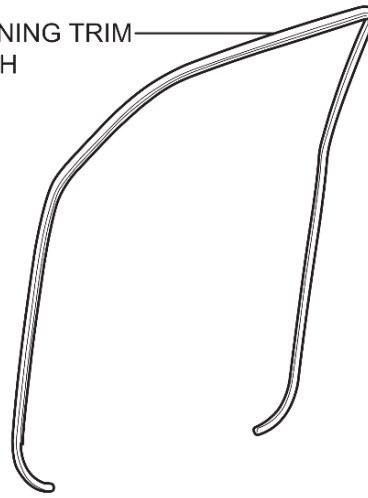

No. 1 ASSIST GRIP

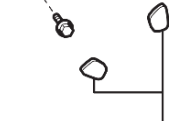

ASSIST GRIP PLUG

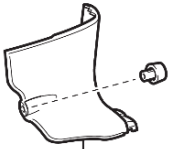

COWL SIDE TRIM BOARD RH



DOOR SCUFF PLATE ASSEMBLY RH



FRONT DOOR OPENING TRIM
WEATHERSTRIP LH

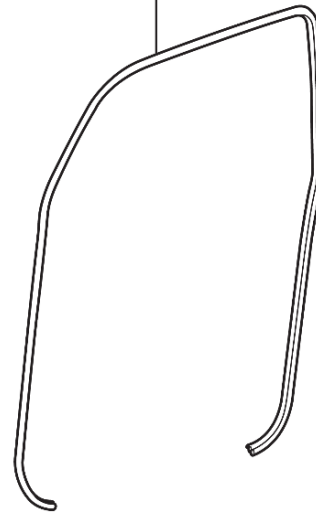

Part manufactured
before August 2013:

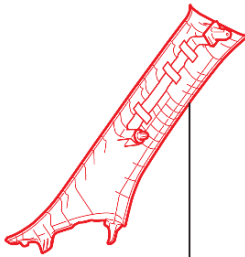

● FRONT PILLAR
GARNISH LH

Part manufactured
after August 2013:

No. 1 FRONT PILLAR
GARNISH COVER LH

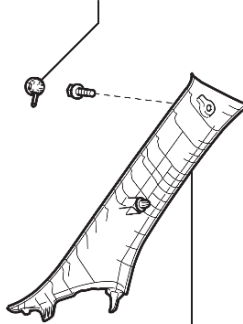

FRONT PILLAR
GARNISH LH

COWL SIDE TRIM BOARD LH

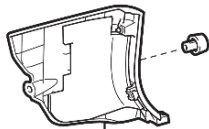

DOOR SCUFF PLATE ASSEMBLY LH



● Replacement part

R1703160011

CAUTION-PLASTIC RETAINING CLIPS ARE FRAGILE. REMOVE WITH CARE

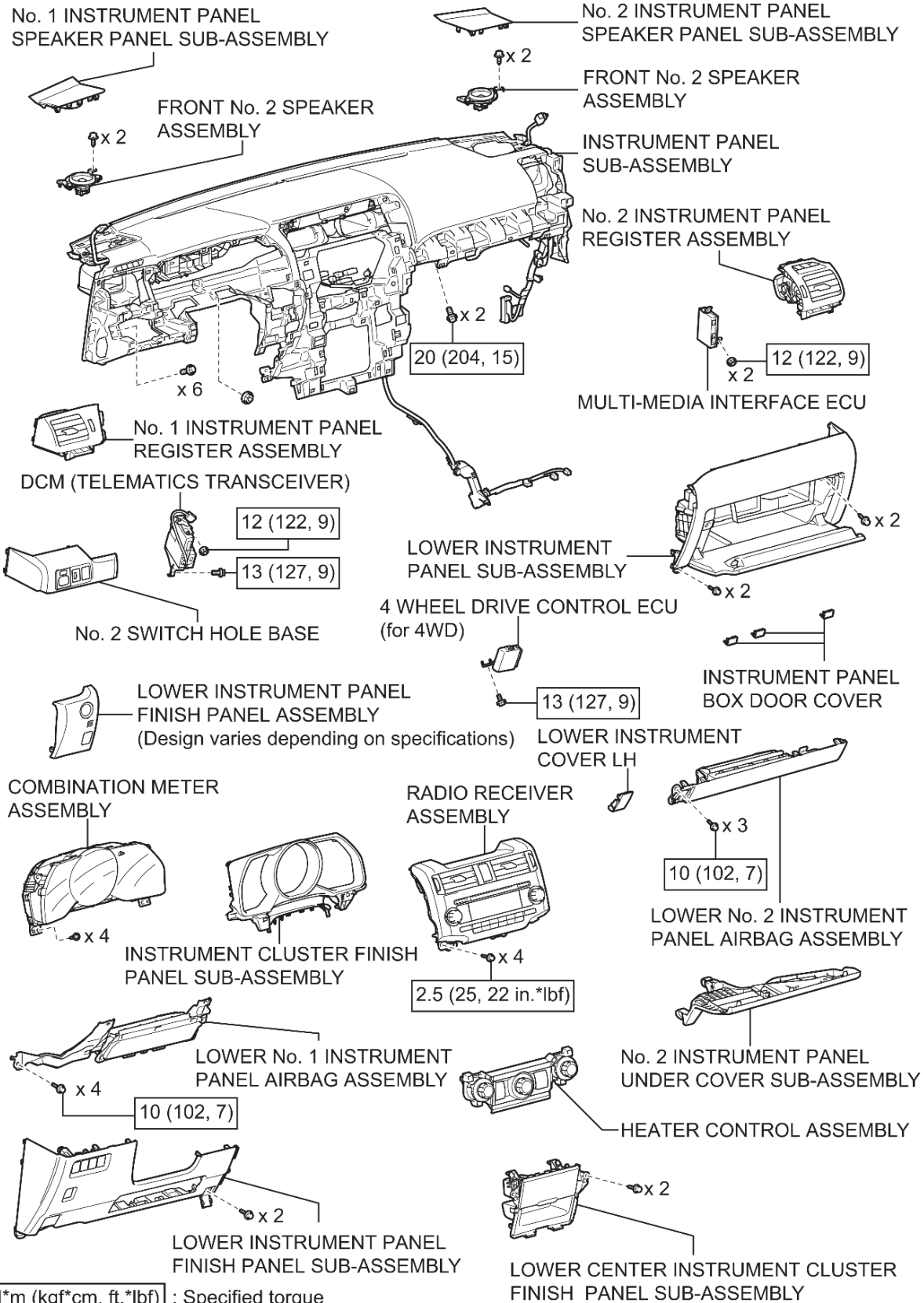

R1703160012

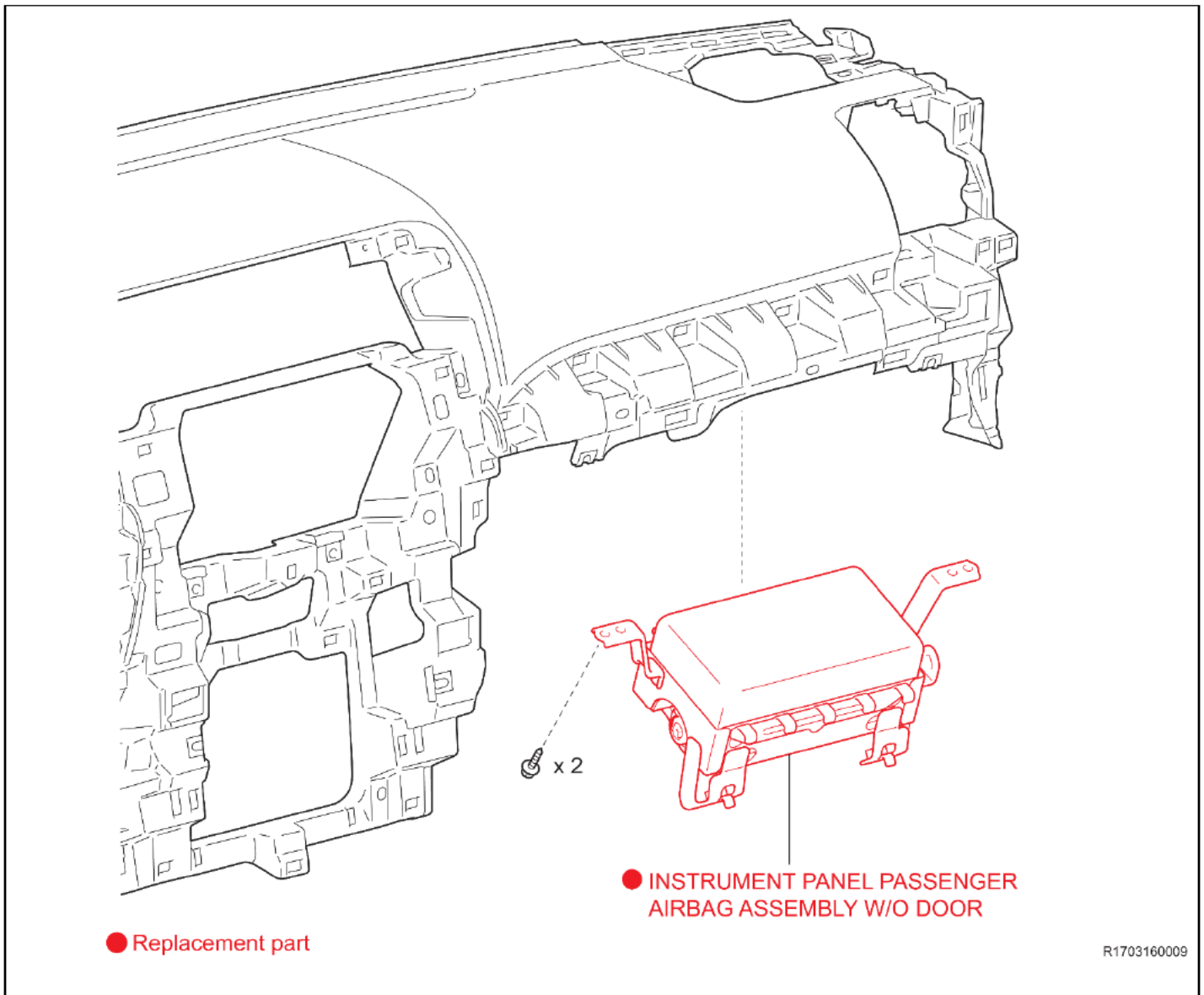

1. REMOVE THE AIRBAG MODULE

a) Refer to TIS for instructions on airbag removal:

2010 MY



- Wait at least 90 seconds after disconnecting the cable from the negative battery terminal to prevent airbag and seat belt pre-tensioner deployment.
- Follow all precautions as outlined on TIS before servicing the SRS system.

NOTE: The left front A-Pillar garnish needs to be replaced on vehicles manufactured prior to August 2013. Only one garnish is required per vehicle depending upon color code. The kit contains the garnish and the non-reusable clip. (see parts information)

2. LAUNCH THE SERIAL NUMBER RECORDING APPLICATION



- The AIRBAG MODULE serial number MUST be recorded using the barcode scanner (provided at the launch of SSC F0J).
- The barcode scanner application MUST be completed on every vehicle. These numbers MUST be included on every warranty claim that is submitted for module replacement or the claim may be subject to debit.
- The technician performing the work MUST have valid TIS login credentials and an internet connection to perform the inspection and scanning process.

- Log in to TIS and input the VIN of the vehicle in the Vehicle Inquiry tab.
- Confirm the VIN is applicable and that the campaign has not been completed.
- Click on the link to launch the serial number recording application.

Note: The Serial Number Recording Application is the same as the previous application, so the screens will still indicate an older campaign.

The screenshot shows the Toyota TIS Vehicle Inquiry application. The VIN search field contains "1NX BR32E 000000000" and is circled in red with a red "a)" next to it. Below the search results, the "Completion Status" is "Not Completed" and is circled in red with a red "b)" next to it. A link "Check applicability for VIN" is circled in red with a red "c)" next to it. The campaign description is "Safety Recall DCF Remedy Notice - 2003-2004 Model Year Corolla, Corolla Matrix, Sequoia, and Tundra Vehicles, 2002-2003 Model Year".

- Reenter TIS password in the serial number recorder application.

NOTE: The person logged-in to TIS MUST be the person performing the repair.

The screenshot shows the Serial Number Recorder application. The title is "Front Passenger Airbag Inflator Module - Safety Recall". The VIN is "1TD0240110000000000" and is circled in red. Below the VIN, there is a "Mileage" field with a red circle around it. The screen also displays user information, dealer code, and a table of tasks.

Task	Dealer	User	Time	Status
Airbag # Record				Not Started
Inflator # Record				Not Started
Frame & Conditions				Not Started
See Airbag #				Not Started

- Record the vehicle mileage into the serial number recording application.

NOTE:

- If this screen indicates that the module has already been replaced on this VIN, there is no need to perform the campaign again.

3. CONNECT THE BARCODE SCANNER

- Connect the barcode scanner to the USB port on the Techstream.
- The scanner will automatically connect and a beep will be heard when the scanner is ready.

NOTE:

- The scanner was provided for SSC F0J.
- The scanner works best in low light conditions.
- Always hold the scanner directly in front of and parallel to the barcode label.

4. SCAN THE AIRBAG SERIAL NUMBER

- Scan the **AIRBAG ASSEMBLY** serial number 2 times.
 - Confirm that the cursor is in the first serial number box then scan the bar code.
 - Position the cursor in the second serial number box and rescan the bar code.

- Click next.

NOTE:

- If both the serial numbers do not match, confirm and reenter.
- If the serial number barcode will not scan, it can be entered manually.

AIRBAG SERIAL NUMBER IDENTIFICATION

- The airbag serial number is **ALWAYS** the 12 **DIGITS** located between the asterisks.
- The 3 digits before the asterisk **ARE NOT** part of the serial number, and **SHOULD NOT** be entered or an inaccurate response may be returned.

Airbag Serial Number Label Example



STOP

The **AIRBAG** serial number **MUST** be recorded prior to replacement.

Front Passenger Airbag Inflator Module - Safety Recall
SSC - E04

User ID: Technician Name:
Dealer Code: Dealer Name:
Time: 03/30/2015 05:15 AM PDT VIN: 1NK BR32E 14 [REDACTED] 2004 Corolla SUPER WHITE

Original Airbag Module - 12 Digits
Between the asterisk (*) symbols

Record Airbag Serial Number

Use of a barcode scanner is strongly recommended when entering Airbag Assembly Serial Number.
If manually typing serial number, you **MUST** include all leading zeros. (If applicable)

* Airbag Assembly Serial Number:
* Reconfirm Airbag Assembly Serial Number:

If original Airbag Assembly serial number is not visible or missing, check this box:

(*) - Indicates Required Field(s)

Click **Next**

- c) Check the box that states that the inflator serial number is not visible or missing.
(DO NOT SCAN THE INFLATORS)
 (this will allow the program to advance to the next screen)

T3: - Google Chrome
 t3qa.tms.toyota.com/t3Portal/portlets/tis/airBag/AirBagController.portlet?...nfpb=true&_windowLabel=StandalonePortlet&StandalonePortlet_actionOverride=%2Fportlets%2Ftis%2F

Front Passenger Airbag Inflator Module - Safety Recall

SSC - E04

User ID: _____ Technician Name: (1) (2) (3) (4) (5)

Dealer Code: _____ Dealer Name: _____

Time: 03/30/2015 05:17 AM PDT VIN: 1NX BR32E 14[REDACTED] 2004 Corolla SUPER WHITE Airbag Serial #: *****12

Original Inflator



How to Identify the Inflator serial code on the Original and Replacement Inflator can?

The Inflator serial code is an **11 digit code** on the Inflator can. It can be found with a bar code on removing the Inflator can from the Airbag Assembly unit.

The first two characters of the **Original Inflator Serial code** will be from [AA, AB, AJ, FD or JD].

The first two characters of the **Replacement Inflator Serial code** will be either 'LT' or 'LR'.

Replacement Inflator



Inflator Module replacement IS REQUIRED on all vehicles under the Safety Recall. Follow the technical instructions and acknowledge the following statements.

If manually typing serial number, you MUST include all leading zeros. (N/A applicable)

Original Inflator Serial #:

If old inflator serial number is not visible or missing, check this box

* Replacement Inflator Serial #:

If you have a concern with the inflator serial numbers, please email quality_compliance@toyota.com with details.

I agree to complete the safety recall's remaining technical instructions.

I agree to perform a vehicle Health Check with Techstream upon completion of the safety recall's technical instructions.

(*) - Indicates Required Field(s)

Back Clear

NOTE: The NEW AIRBAG serial number MUST be scanned prior to reinstallation to track the airbag to the vehicle (refer to page 13).

- d) Click submit.

e) Scan the NEW airbag barcode in the Serial Number Recording Application.

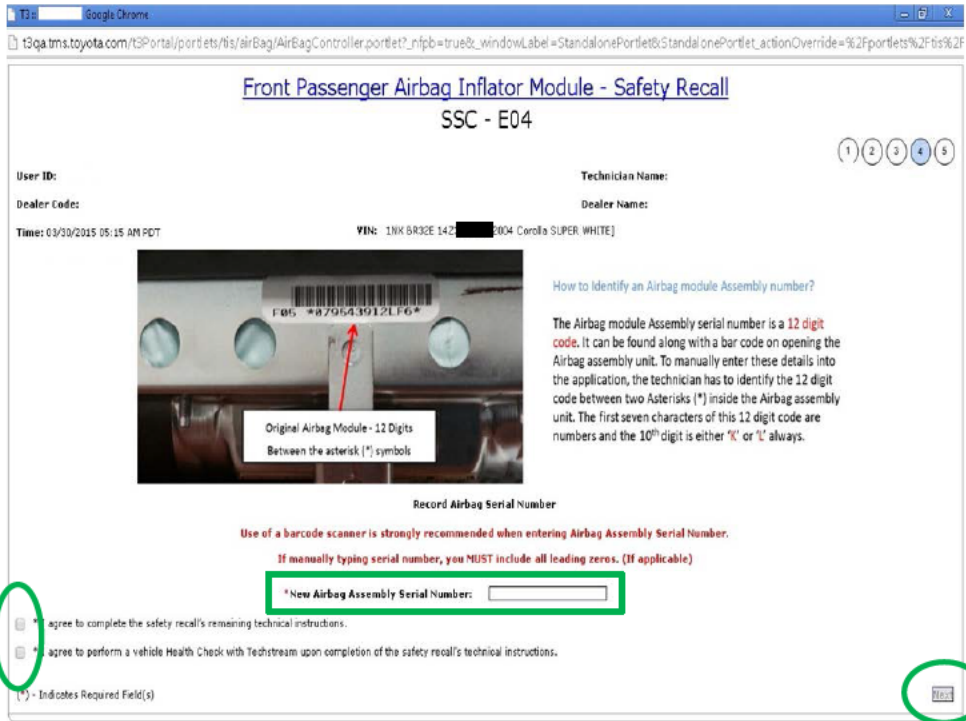

- f) Verify the statements and click the two boxes.
- g) Click next.

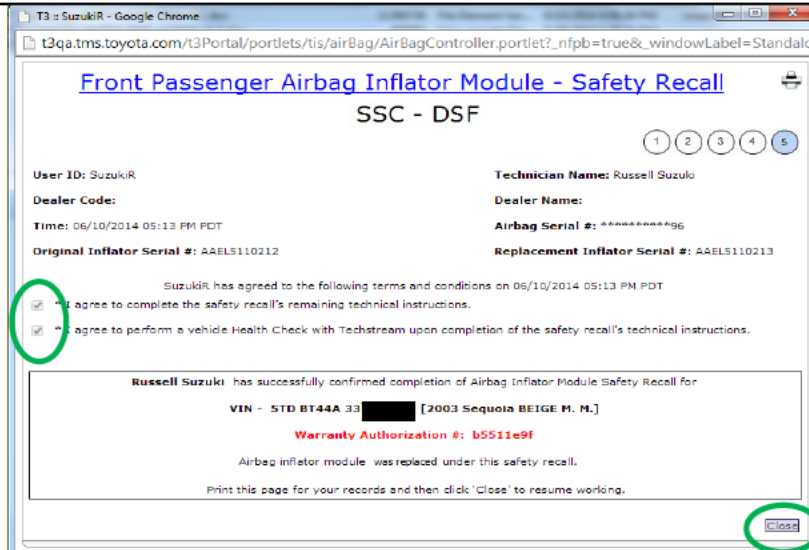

- h) Confirm agreement by checking the two boxes.
- i) Record the Warranty Authorization # to be included in the warranty claim.
- j) Place the old module in the parts box and take it immediately to the parts department.

NOTE:

- Confirm the cursor is in the correct serial number input box before scanning.
- If the serial number barcode will not scan, it can be entered manually.
- If there are any difficulties or concerns with this process, email quality_compliance@toyota.com with details.

AIRBAG SERIAL NUMBER IS MISSING OR IS UNREADABLE



If the airbag serial number and barcode are not legible or are not present, check the box in the application indicating the serial number is not legible.

a) If the airbag serial number cannot be scanned or is not present check the box as shown below.

T3: Google Chrome
t3qa.tms.toyota.com/t3Portal/portlets/tis/airBag/AirBagController.portlet?...
Front Passenger Airbag Inflator Module - Safety Recall
SSC - E04

1 2 3 4 5

User ID: Technician Name:
Dealer Code: Dealer Name:
Time: 03/30/2015 05:15 AM PDT VIN: 1NX BR32E 14... [2004 Corolla SUPER WHITE]



Original Airbag Module - 12 Digits
Between the asterisk (*) symbols

Record Airbag Serial Number

How to Identify an Airbag module Assembly number?
The Airbag module Assembly serial number is a 12 digit code. It can be found along with a bar code on opening the Airbag assembly unit. To manually enter these details into the application, the technician has to identify the 12 digit code between two Asterisks (*) inside the Airbag assembly unit. The first seven characters of this 12 digit code are numbers and the 10th digit is either 'K' or 'L' always.

Use of a barcode scanner is strongly recommended when entering Airbag Assembly Serial Number.
If manually typing serial number, you MUST include all leading zeros. (If applicable)

* Airbag Assembly Serial Number:
* Reconfirm Airbag Assembly Serial Number:

If original Airbag Assembly serial number is not visible or missing, check this box:

Clear Next

(*) - Indicates Required Field(s)

Check this box if the label is damaged or missing

b) Go to Page 12 to continue airbag scanning.

VIII. FRONT PASSENGER AIRBAG REINSTALLATION

1. INSTALL THE NEW AIRBAG

- a) Refer to TIS for instructions on airbag installation:

[2010 MY](#)

2. RECONNECT THE NEGATIVE BATTERY CABLE
3. PREFORM ANY NEEDED VEHICLE INITIALIZATIONS
4. PERFORM A HEALTH CHECK AND DIAGNOSTIC REPORT

◀ VERIFY REPAIR QUALITY ▶

- Confirm all precautions are followed to ensure safety during the repair
- Confirm the entire serial number checker application is completed and the warranty authorization # is recorded on **EVERY** vehicle
- Confirm the old module is handled safely and given to the appropriate parts professional for shipment

If you have any questions regarding this update, please contact your regional representative.

IX APPENDIX

A. CAMPAIGN DESIGNATION DECODER

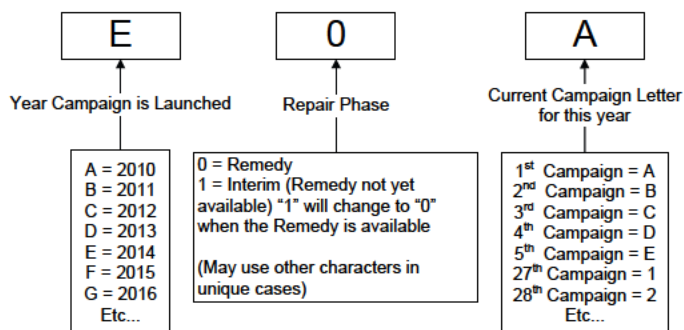

Examples:

A0D = Launched in 2010, Remedy Phase, 4th Campaign Launched in 2010

B1E = Launched in 2011, Interim Phase, 5th Campaign Launched in 2011

C1C = Launched in 2012, Interim Phase, 3rd Campaign Launched in 2012

B. CAMPAIGN PARTS DISPOSAL

ALL inflators that are removed from vehicles under this campaign **MUST** be packaged and shipped back to the inflator manufacturer following the manufacturer's instructions. The instructions can be found in the following locations:

- Attached to the dealer letter
- Included in the parts box