

# IMPORTANT UPDATE

## TECHNICAL INSTRUCTIONS

FOR

SAFETY RECALL G0P/G0R/H0A

FRONT PASSENGER AIRBAG INFLATOR MODULE

CERTAIN 2010-2016 MY 4Runner

**Updated 01-14-2021**

### Update 01-14-21

- The scanning application process has been updated

### Update 1-11-19

- Added inspection for A-Pillar Garnish

### Update 1-9-19

- Added up to 2016 MY
- Updated title to include G0R and H0A

### Update 11-20-18

- The parts section has been updated

### Update 09-5-18

- The parts section has been updated

### Update 07-17-18

- The Technician Certification Requirements have changed

### 4/18/18 Update

- The parts section has been updated

### 1/9/18 Update

- Added 2013 MY

### 11/2/17 Update

- Added additional part options
- Added 2012 MY

### 8/31/17 Update

- Added 2011 MY
- Caution added in parts diagram section

All dealership technicians performing this recall are required to successfully complete the most current version of the E-Learning course "Safety Recall and Service Campaign Essentials". To ensure that all vehicles have the repair performed correctly; technicians performing this recall repair are required to have successfully completed E-Learning course SC18A (if you had previously completed E-Learning Course SC13B, you do not have to take SC18A), in addition to "Safety Recall and Service Campaign Essentials", and currently hold at least one of the following certifications levels:

- Toyota Certified (Electrical)
- Toyota Expert (Any Specialty)
- Master
- Master Diagnostic Technicians

Always check which technicians can perform the recall remedy by logging on to <https://www.uotdealerreports.com>. It is the dealership's responsibility to select technicians with the above certification level or greater to perform this repair. Carefully review your resources, the technician skill level, and ability before assigning technicians to this repair. It is important to consider technician days off and vacation schedules to ensure there are properly trained technicians available to perform this repair at all times.

## I. OPERATION FLOW CHART

The flow chart is for reference only. **DO NOT** use it in place of the full technical instructions. Follow **ALL** steps as outlined in the full technical instructions to confirm the campaign is completed correctly.

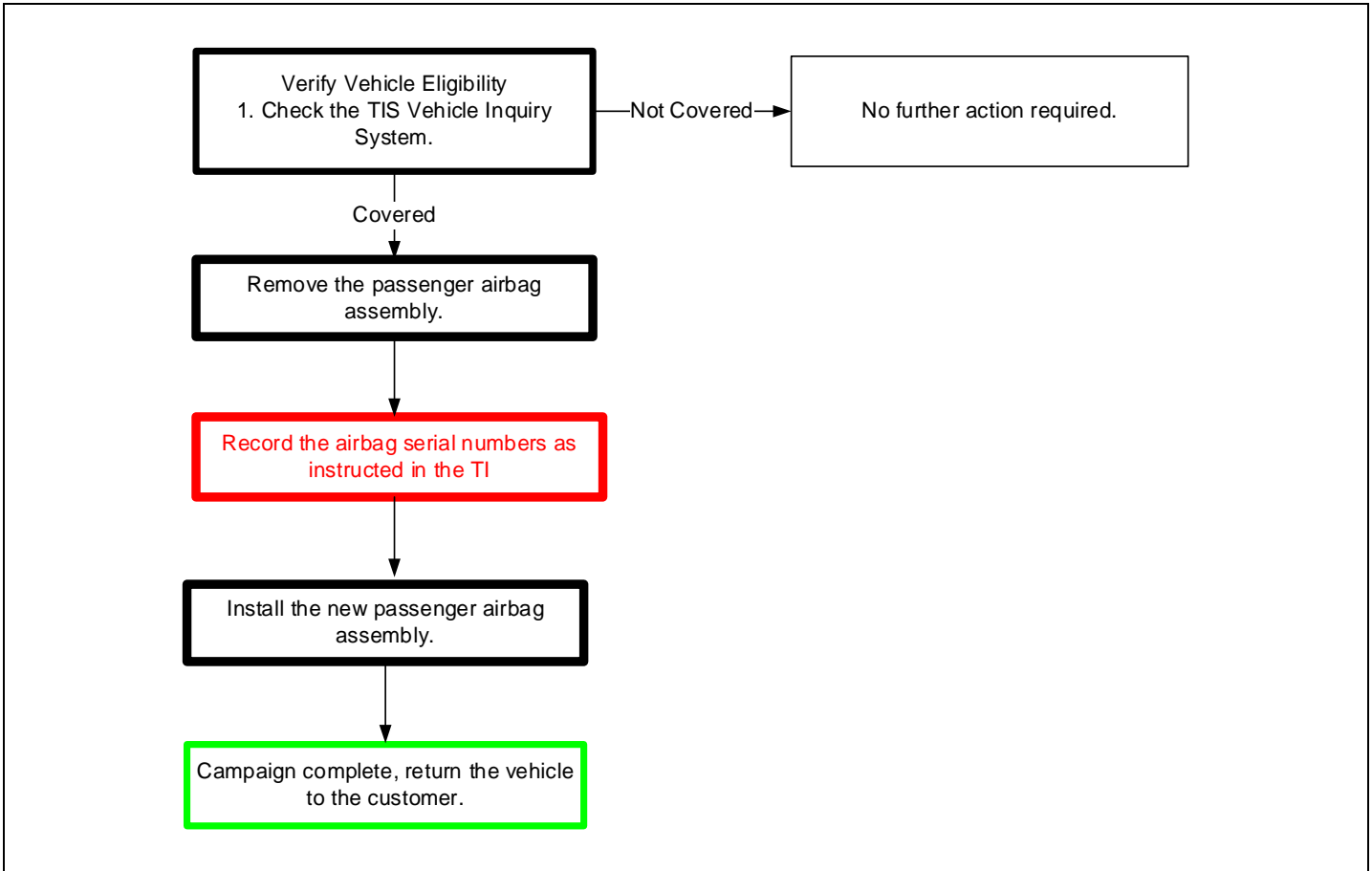

## II. BACKGROUND

The subject vehicles are equipped with front passenger airbag inflators produced by Takata. According to Takata, the propellant in these inflators may degrade after prolonged exposure to high absolute humidity and fluctuating high temperatures. Degraded propellant can cause inflator rupture during airbag deployment. In the event of an inflator rupture, metal fragments could pass through the airbag cushion material, striking the vehicle occupants, and result in serious injury or death.

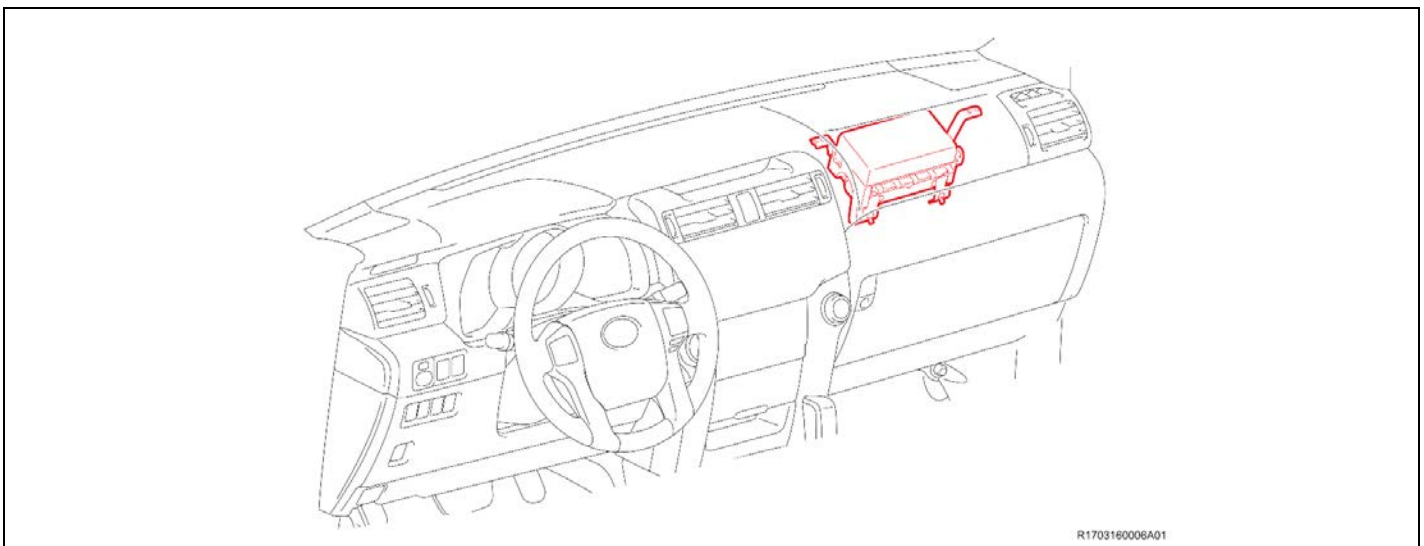

### III. IDENTIFICATION OF AFFECTED VEHICLES

- Check the TIS Vehicle Inquiry System to confirm the VIN is involved in this Safety Recall, and that the campaign has not already been completed prior to dealer shipment or by another dealer.
- **TMS warranty will not reimburse dealers for repairs conducted on vehicles that are not affected or were completed by another dealer.**

### IV. PREPARATION



#### A. PARTS

<u>Model/Model Year</u>	<u>Part Number</u>	<u>Part Description</u>	<u>Quantity</u>
2010-2016 4Runner	*04007-58135	Instrument Panel Airbag Module	1
	**04007-1U135-B0 - Light Gray Interior Or **04007-1U135-E0 - Sand Beige Interior	A-Pillar Garnish	1

**\*Note:** 04007-14335 is no longer available to order from your facing PDC. This part number is still valid for the repair, however. If you have remaining inventory at your dealer, please continue to use in conjunction with the above A-Pillar garnishes (if required) when repairing 4Runner vehicles until your inventory has been depleted. Once gone, start using 04007-58135 for the repair.

\*\*62220-35030-B0 and 62220-35030-E0 are no longer available to order for this safety recall. Please begin using the campaign specific part numbers 04007-1U135-B0 and 04007-1U135-E0 when replacing the A-Pillar Garnish.

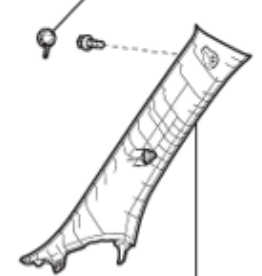
\*\*Only 2010 to Certain 2013 Model Year 4Runner vehicles require A-Pillar garnish replacement. If you have a 2013 – 2016 4Runner that contains an A- Pillar garnish that is bolted in at the top, the A-Pillar **DOES NOT** require replacement. See photos below for reference.

REPLACE	RE-USE GARNISH	
<p>Part manufactured before August 2013:</p>  <p style="color: red; text-align: center;">● FRONT PILLAR GARNISH LH</p>	<p>Part manufactured after August 2013:</p> <p>No. 1 FRONT PILLAR GARNISH COVER LH</p>  <p style="text-align: center;">FRONT PILLAR GARNISH LH</p>	

**Non-Desiccated Part Recovery**

**Dealers should discontinue the installation of the non-desiccated parts listed below for recall, customer pay repairs AND over-the-counter sales (if applicable).**

Model	Model Year	Part Number	Part Description
4Runner	2010-2016	73960-35080 73960-35081	AIR BAG ASSY, INSTR PNL PASS

**Toyota requires all dealers to return any parts listed above that still remain in dealer inventory by utilizing the Hazmat Part Return Program available. Dealers will be issued a refund for all part returns. This part return program is outlined in *PANT Bulletin 2014-042*.**

**Important Note:**

In order to return the inflator, packages must **NOT** be opened/tampered with.

**A. TOOLS & EQUIPMENT**

- Standard hand tools
- Torque wrench
- Techstream
- Molding remover set

**G0P/G0R/H0A CAMPAIGN TOOLS** – These tools are required when performing this repair.

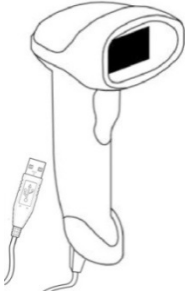
Image	Name	Quantity
	Barcode Scanner (The scanner distributed for F0J can read bar and QR codes)	1

**NOTE: This scanner CANNOT be ordered through the parts or tools system. If additional tools are needed, they can be sourced locally.**

**SST** –These are essential service tools that the dealership should have.

Part Number	Part Name	Quantity
09950-50013	Puller C Set *	1
* The set above includes the following tools.		
Part Number	Part Name	Quantity
09951-05010	Hanger 150	1
09952-05010	Slide Arm	2
09953-05020	Center Bolt 150	1
09954-05070	Claw No. 7	2

## V. SAFETY PRECAUTIONS



### CRITICAL INFORMATION – READ THOROUGHLY



Failure to follow these procedures correctly could cause the SRS to unexpectedly deploy during servicing or the SRS may fail to operate correctly when required after reassembly. Confirm all work is performed as described in these instructions.

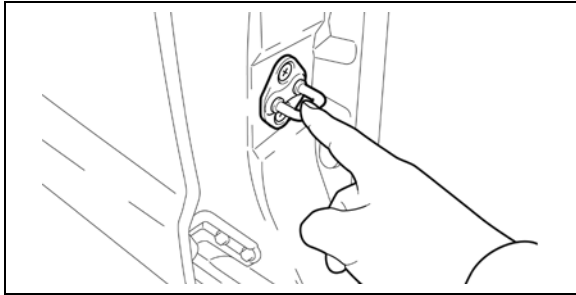

#### 1. ELIMINATE STATIC ELECTRICITY

- a) Before starting work and periodically while working on the vehicle, touch a metallic part of the vehicle to discharge static electricity in the body.



#### 2. DO NOT MEASURE RESISTANCE

- a) **DO NOT** measure resistance of airbag components, this may cause accidental activation.

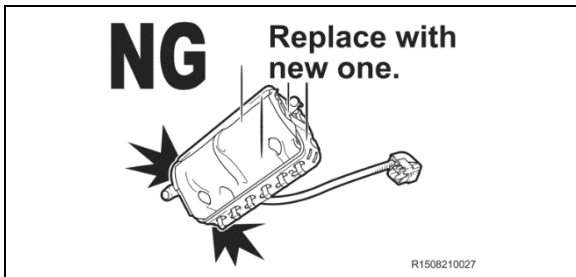

#### 3. HANDLE THE AIRBAG CAREFULLY

- a) If an airbag is dropped, replace it with a **NEW** one.

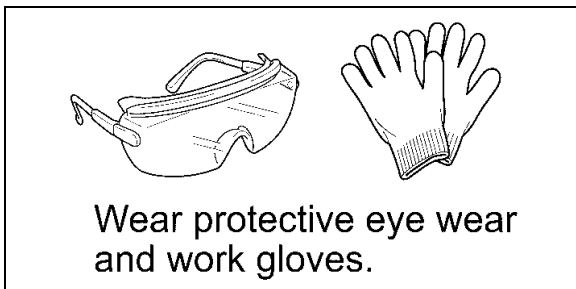

#### 4. WEAR PROTECTIVE EQUIPMENT

- a) Always wear appropriate protective equipment when working on the SRS.



# VII. PASSENGER AIRBAG MODULE REPLACEMENT

**CAUTION-PLASTIC RETAINING CLIPS ARE FRAGILE. REMOVE WITH CARE**

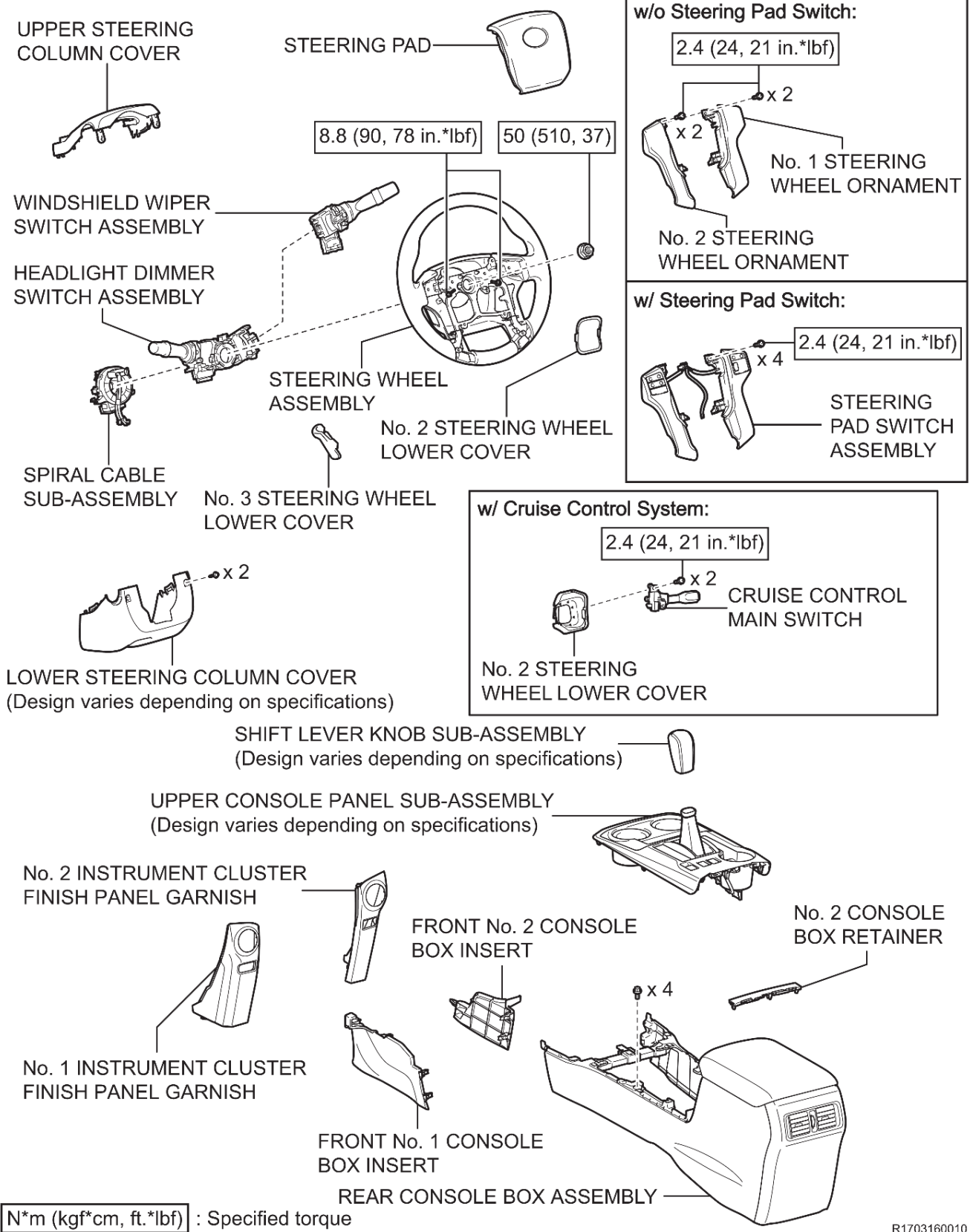

**N\*m (kgf\*cm, ft.\*lbf) : Specified torque**

R1703160010

FRONT PILLAR  
GARNISH RH

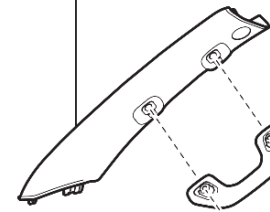

FRONT DOOR OPENING TRIM  
WEATHERSTRIP RH

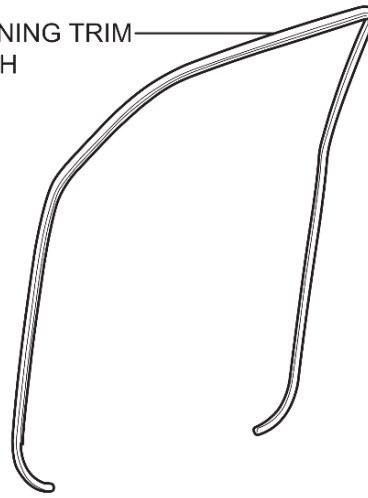

No. 1 ASSIST GRIP

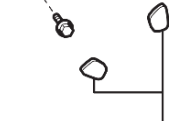

ASSIST GRIP PLUG

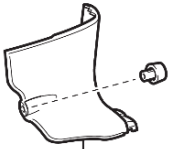

COWL SIDE TRIM BOARD RH

DOOR SCUFF PLATE ASSEMBLY RH

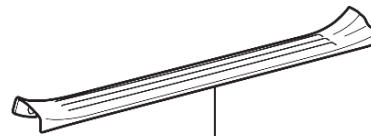

FRONT DOOR OPENING TRIM  
WEATHERSTRIP LH

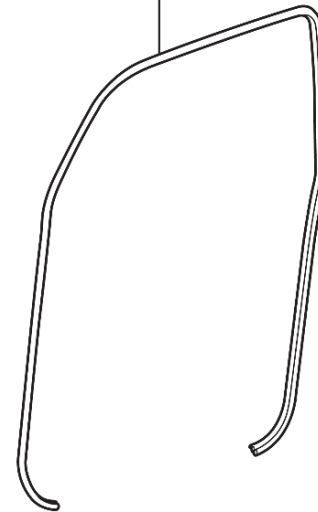

Part manufactured  
before August 2013:

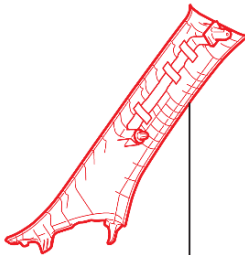

● FRONT PILLAR  
GARNISH LH

Part manufactured  
after August 2013:

No. 1 FRONT PILLAR  
GARNISH COVER LH

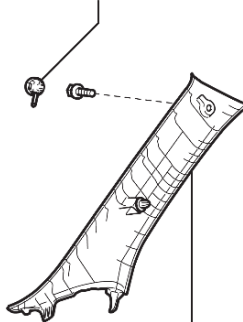

FRONT PILLAR  
GARNISH LH

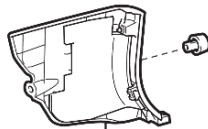

COWL SIDE TRIM BOARD LH

DOOR SCUFF PLATE ASSEMBLY LH



● Replacement part

R1703160011

**CAUTION-PLASTIC RETAINING CLIPS ARE FRAGILE. REMOVE WITH CARE**

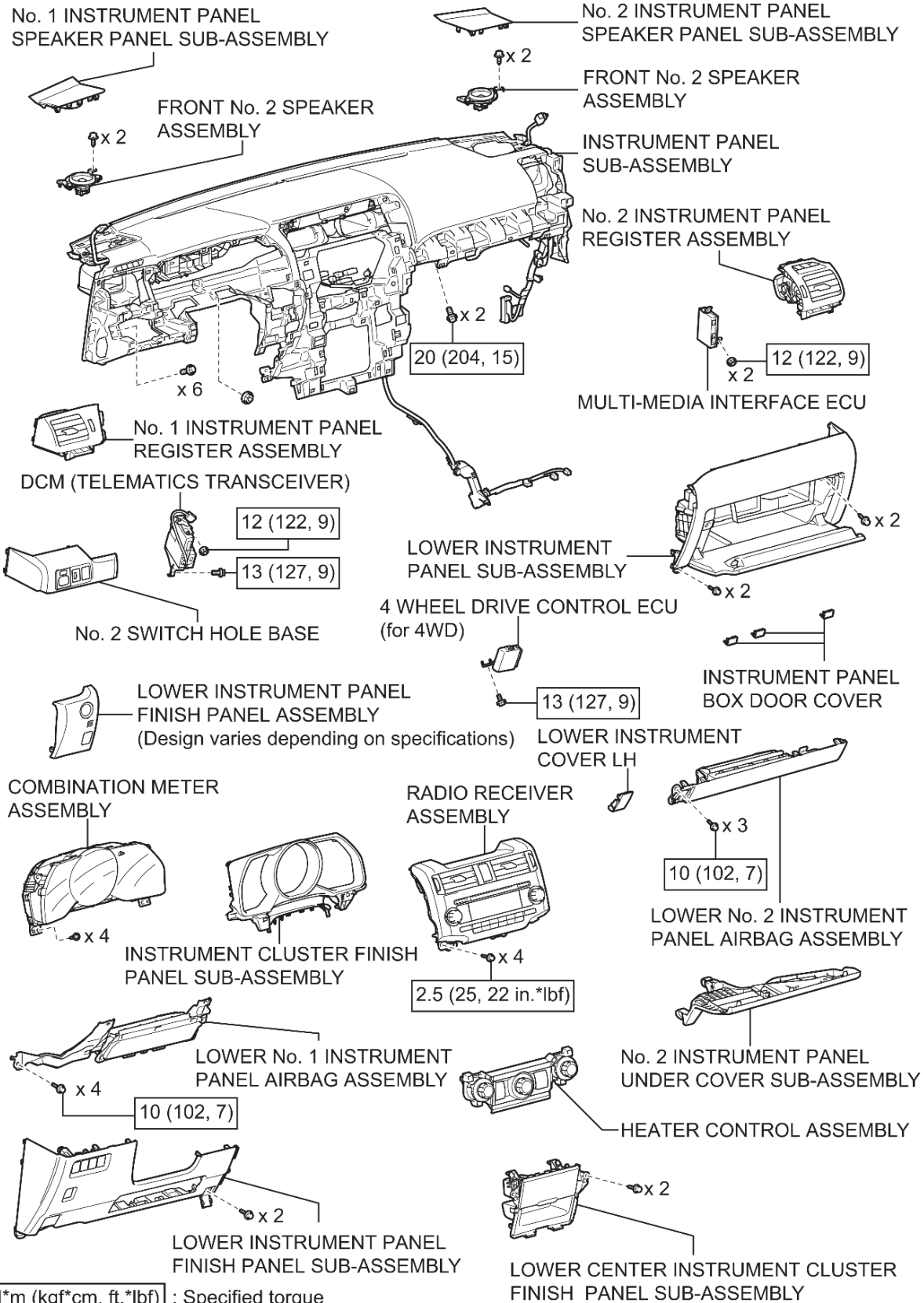

N\*m (kgf\*cm, ft.\*lbf) : Specified torque

R1703160012

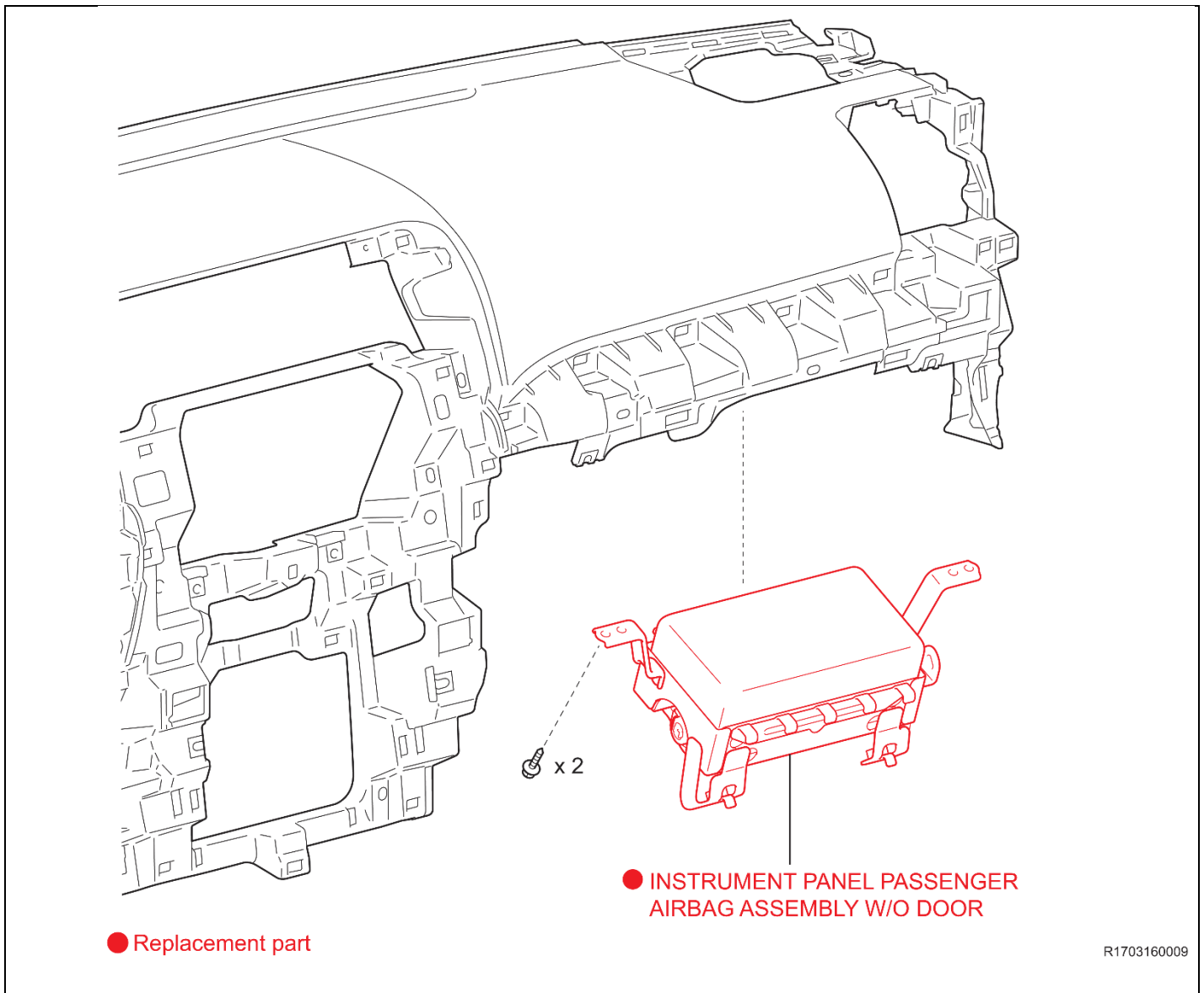

## 1. REMOVE THE AIRBAG MODULE

a) Refer to TIS for instructions on airbag removal:

[2010 MY](#) [2011 MY](#) [2012 MY](#) [2013 MY](#) [2014 MY](#) [2015 MY](#) [2016 MY](#)



- Wait at least 90 seconds after disconnecting the cable from the negative battery terminal to prevent airbag and seat belt pre-tensioner deployment.
- Follow all precautions as outlined on TIS before servicing the SRS system.

**NOTE:** The left front A-Pillar garnish needs to be replaced on vehicles manufactured prior to August 2013. Only one garnish is required per vehicle depending upon color code. The kit contains the garnish and the non-reusable clip. (see parts information)

## 2. LAUNCH THE SERIAL NUMBER RECORDING APPLICATION



- The AIRBAG MODULE serial number **MUST** be recorded using the barcode scanner (provided at the launch of SSC F0J).
- The barcode scanner application **MUST** be completed on every vehicle. These numbers **MUST** be included on every warranty claim that is submitted for module replacement or the claim may be subject to debit.
- The technician performing the work **MUST** have valid TIS login credentials and an internet connection to perform the inspection and scanning process.

- a) Log in to TIS and input the VIN of the vehicle in the Vehicle Inquiry tab.
- b) Confirm the VIN is applicable and that the campaign has not been completed.
- c) Click on the link to be sent to the scanning application site.
- d) You can also log into the scanning site via the URL below

Log into the website via the URL below  
<https://takata-scan-app.imagespm.info/>

User ID: Dealer Code  
First time login password: xxxxx

The screenshot shows the Toyota TIS Vehicle Inquiry interface. At the top, there are navigation tabs for Home, TIS, TAS, PRS, and QAT. The TIS tab is selected. Below the navigation, there are tabs for Library, Diagnostics, Tech Assistance, and Vehicle Inquiry. The Vehicle Inquiry tab is active, displaying a 'Vehicle Identification Number Search' form. The VIN '1NX-BR32E-000000000' is entered in the search field, which is circled in red and labeled 'a)'. Below the search form, the 'Vehicle Information' section displays details for a 2003 Toyota Corolla CE, including drive type, body type, engine family, transmission, production date, and exterior/interior colors. Below this, there are tabs for Campaign, Service History, Warranty, DTC History, and Diagnostic Report. The Campaign tab is selected, showing a 'Service Campaign' for a Safety Recall D0F Remedy Notice. The 'Completion Status' is 'Not Completed', which is circled in red and labeled 'b)'. A link to 'check applicability for VIN' is also circled in red and labeled 'c)'. The footer of the page includes the copyright notice '© 2013 Toyota Motor Sales, Inc.' and links for Feedback, Privacy, and Legal.

# Login

Complete all required (\*) fields below.

**\* User ID (enter your 5-digit dealer code, or 6-digit for Canadian dealers eg. Cnnnnn format):**

**\* Password:**

**Login**

[Forgot Password?](#)

**Technician Information**

Please provide information below before searching for VIN.

**Technician Name:**

**SPIN ID (12 digit code):**

**Search**

a) Enter your name and SPIN ID into the site

**Enter VIN**

Enter the 17-digit Vehicle Identification Number to begin the search for this campaign.

**VIN:**

**Mileage on Vehicle:**

**Search**

b) Enter the VIN and vehicle mileage into the site

## 1. CONNECT THE BARCODE SCANNER

- Connect the barcode scanner to the USB port on the Techstream.
- The scanner will automatically connect and a beep will be heard when the scanner is ready.

### NOTE:

- **The scanner was provided for SSC F0J.**
- **The barcode scanner works best in low light conditions.**
- **Always hold the scanner directly in front of and parallel to the barcode label.**

## 2. SCAN THE AIRBAG SERIAL NUMBER

# ATTENTION: This information is **CRITICAL**

- a) Scan the **AIRBAG ASSEMBLY** serial number 2 times.
  - 1) Confirm that the cursor is in the first serial number box and scan the bar code.
  - 2) Position the cursor in the second serial number box and rescan the bar code.
- b) Click next.

### NOTE:

- If the serial numbers do not match, confirm and reenter.
- If the serial number barcode will not scan, it can be entered manually.

### AIRBAG SERIAL NUMBER IDENTIFICATION

- The airbag serial number is **ALWAYS** the 12 **DIGITS** located between the asterisks.
- The 3 digits before the asterisk **ARE NOT** part of the serial number, and **SHOULD NOT** be entered or an inaccurate response may be returned.

### Airbag Serial Number Label Example



The **AIRBAG ASSEMBLY** serial number **MUST** be recorded prior to replacement.

## ORIGINAL Airbag Assembly Serial Number

Scan or enter the **original** Airbag Assembly serial number into the website.

VIN:  
Model / Campaign:

\* Serial Number of *Original* Airbag Assembly:

\* Re-confirm the Serial Number of *Original* Airbag Assembly:

Check if the airbag serial number is missing or not visible, or if installing a new airbag assembly

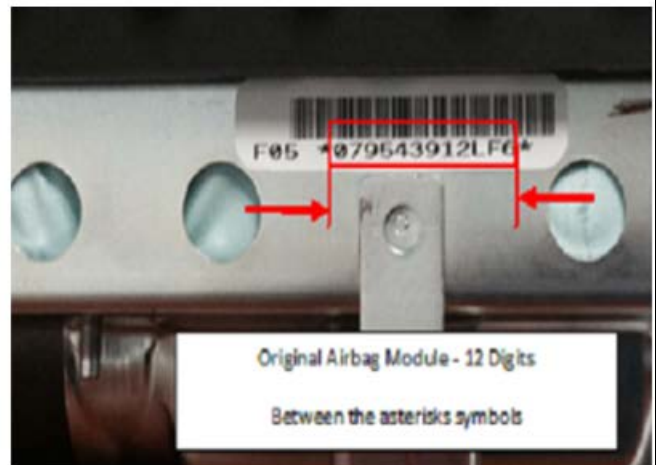

c) Scan the **NEW** Airbag barcode in the Serial Number Recording Application.



Takata Scan App

TMS Test Dealership

[Search Another VIN](#) | [Print Screen](#) | [Log Out](#)

## NEW Serial Number

Scan or enter the **new** Airbag Assembly Serial Number into the website.

VIN:

\* Serial Number of New Airbag Assembly:

\* Re-confirm the Serial Number of New Airbag Assembly:

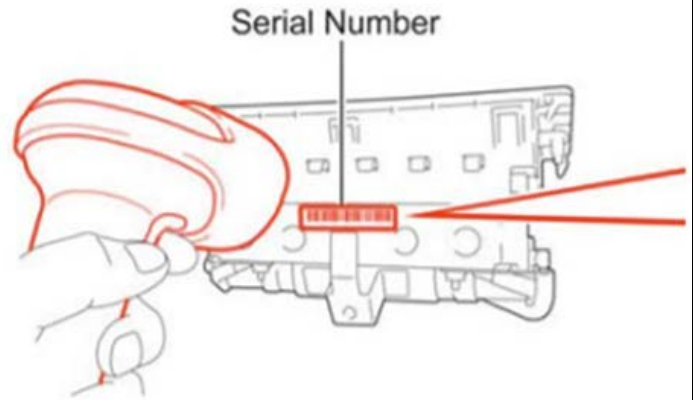

The new **AIRBAG ASSEMBLY** serial number **MUST** be recorded prior to reinstallation to track the airbag assembly to the vehicle.

d) Record the Warranty Authorization # to be included in the warranty claim.

## Takata Scan App (TEST v2) Final Results

You can [Print Screen](#) or [Search Another VIN](#).

<b>Results:</b>	<b>Inflator Replacement Required</b>
<b>Warranty Authorization Number:</b>	<b>77515K46</b> <i>This number is required for the warranty claim. Print and save this screen for your records</i>
<b>VIN:</b>	2T1BR32E57C810829
<b>Vehicle:</b>	2007 Corolla
<b>Campaign:</b>	E04
<b>Original Airbag Serial:</b>	123456789K12
<b>Replacement Airbag Serial:</b>	
<b>Original Inflator Serial:</b>	W0123456789
<b>Replacement Inflator Serial:</b>	W0123456789
<b>Scan Date:</b>	12/22/2020 08:47AM (mm/dd/yyyy)

e) Confirm agreement by checking the two boxes.

f) Place the old airbag in the parts box and return it to the parts department.

**NOTE:**

- Keep all shipping paperwork with the box that it came in.
- Confirm the cursor is in the correct serial number input box before scanning.
- If the serial number barcode will not scan, it can be entered manually.
- If there are any difficulties or concerns with this process, email [quality\\_compliance@toyota.com](mailto:quality_compliance@toyota.com) with details.

## VIII. FRONT PASSENGER AIRBAG REINSTALLATION

### 1. INSTALL THE NEW AIRBAG

a) Refer to TIS for instructions on airbag installation:

[2010 MY](#) [2011 MY](#) [2012 MY](#) [2013 MY](#) [2014 MY](#) [2015 MY](#) [2016 MY](#)

2. RECONNECT THE NEGATIVE BATTERY CABLE
3. PREFORM ANY NEEDED VEHICLE INITIALIZATIONS
4. PERFORM A HEALTH CHECK AND DIAGNOSTIC REPORT

## ◀ VERIFY REPAIR QUALITY ▶

- Confirm all precautions are follow to ensure safety during the repair
- Confirm the entire serial number checker application is completed and the warranty authorization # is recorded on *EVERY* vehicle
- Confirm the old module is handled safely and given to the appropriate parts professional for shipment

If you have any questions regarding this update, please contact your regional representative.

## IX APPENDIX

### A. CAMPAIGN DESIGNATION DECODER

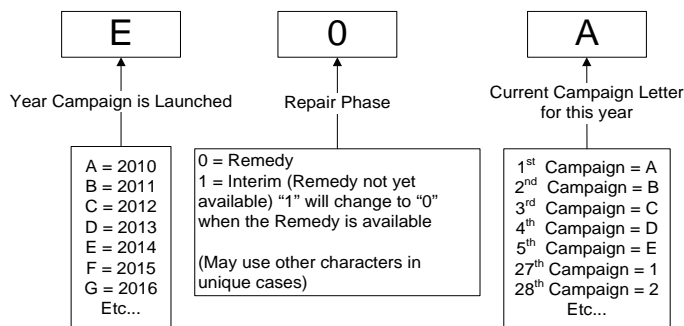

Examples:

A0D = Launched in 2010, Remedy Phase, 4<sup>th</sup> Campaign Launched in 2010

B1E = Launched in 2011, Interim Phase, 5<sup>th</sup> Campaign Launched in 2011

C1C = Launched in 2012, Interim Phase, 3<sup>rd</sup> Campaign Launched in 2012

### B. CAMPAIGN PARTS DISPOSAL

**ALL** inflators that are removed from vehicles under this campaign **MUST** be packaged and shipped back to the inflator manufacturer following the manufacturer's instructions. The instructions can be found in the following locations:

- Attached to the dealer letter
- Included in the parts box