

IMPORTANT UPDATE

TECHNICAL INSTRUCTIONS

FOR

SAFETY RECALL GLG/GLH and HLA

(Note: These technical instructions may be used on any IS 250/350 or IS F vehicle covered under GLG/GLH and HLA)

FRONT PASSENGER AIRBAG MODULE

CERTAIN 2006 – 2013 MY IS 250/350 and 2008 – 2013 MY IS F

Updated 6-14-18

Update 6-14-18

- **Correction to the parts section. Front Pillar Garnish clip is required for any airbag replacement**

Update 4-18-18

- The parts section has been updated
- Added inflator part option
- Previous update made obsolete (Update 2-28-17)
- Removed cross bar bolt replacement

Update 1-9-18

- 2013 MY added

Update 3-2-17

- 2012 MY added

Update 3-1-17

- Update to the scanner wording on page 13.

Update 2-28-17



~~The scanning information on page 45 has been updated. There is NO NEED to scan the inflators. This model requires replacement of the Airbag Module only.~~

Update 2-24-17

- Added replacement of airbag attachment bolts and part number.

Update 2-9-17

- Updated Technician Certification.

The repair quality of covered vehicles is extremely important to Lexus. All dealership technicians performing this recall are required to successfully complete the most current version of the E-Learning course "Safety Recall and Service Campaign Essentials". To ensure that all vehicles have the repair performed correctly:

- **MASTER SERVICE TECHNICIANS**
- **MASTER DIAGNOSTIC SPECIALISTS**

It is the dealership's responsibility to select technicians with the above certification level or greater to perform this recall repair. Carefully review your resources, the technician skill level, and ability before assigning technicians to this repair. It is important to consider technician days off and vacation schedules to ensure there are properly trained technicians available to perform this repair at all times.

NOTE: To support additional service capacity, Lexus Certified and Senior Service Technicians, with at least 36 months Lexus experience AND L652 course credit, may also perform this repair following successful completion of course LSC13B.

I. OPERATION FLOW CHART

The flow chart is for reference only. **DO NOT** use it in place of the full technical instructions. Follow **ALL** steps as outlined in the full technical instructions to confirm the campaign is completed correctly.

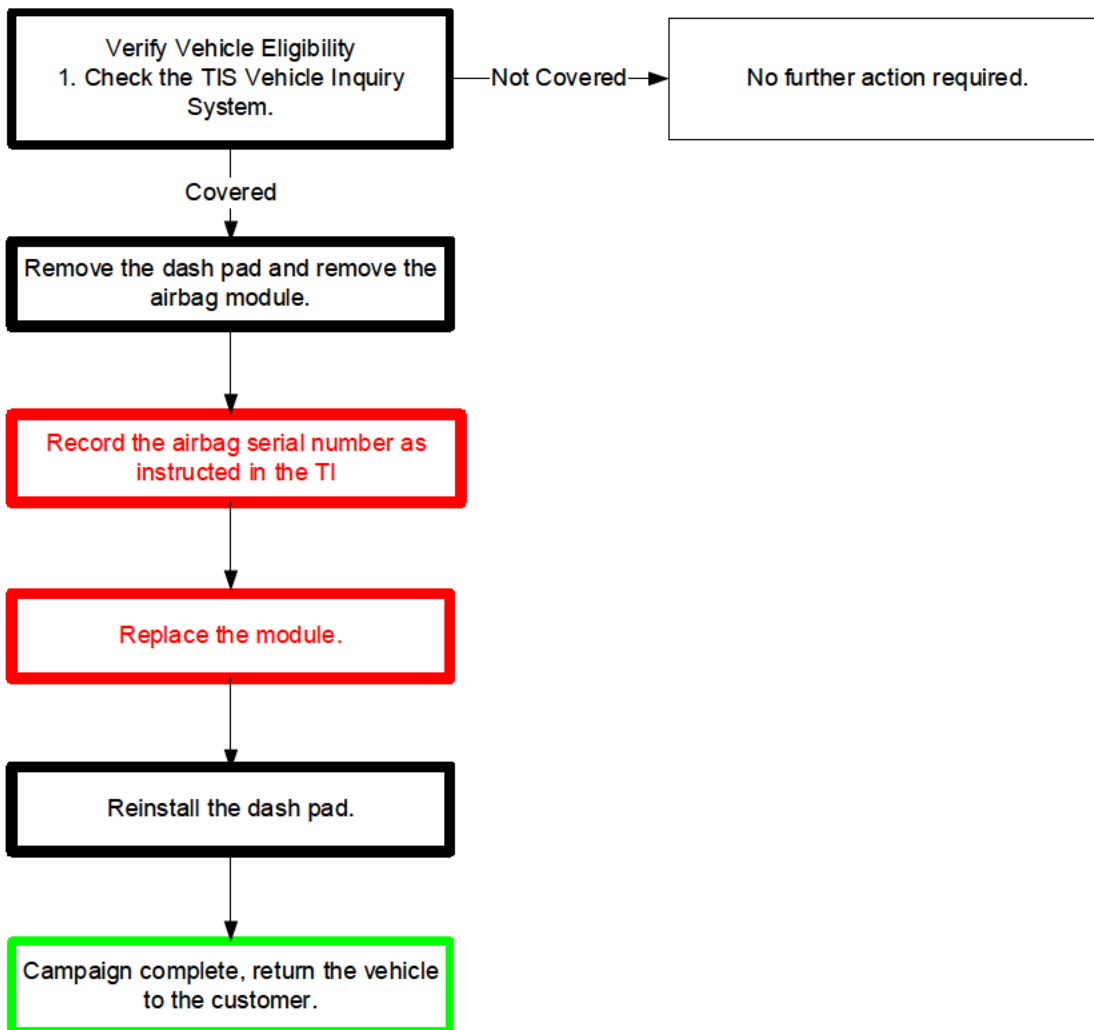

II. BACKGROUND

The subject vehicles are equipped with front passenger airbag inflators produced by Takata. The propellant in these inflators may degrade after prolonged exposure to high absolute humidity and fluctuating high temperatures. Degraded propellant can cause inflator rupture during airbag deployment. In the event of an inflator rupture, metal fragments could pass through the airbag cushion material, striking the vehicle occupants, and result in serious injury or death.

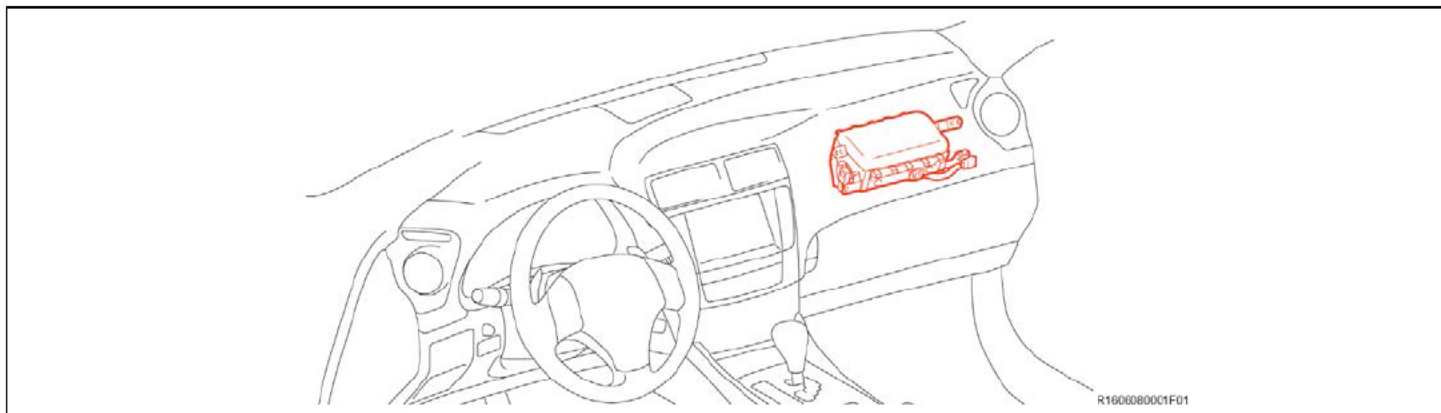

III. IDENTIFICATION OF AFFECTED VEHICLES

A. COVERED VIN RANGE

- Check the TIS Vehicle Inquiry System to confirm the VIN is involved in this Safety Recall, and that the campaign has not already been completed prior to dealer shipment or by another dealer.
- **TMS warranty will not reimburse dealers for repairs conducted on vehicles that are not affected or were completed by another dealer.**

IV. PREPARATION

A. PARTS

Part Number	Part Description	Quantity
04006-29353	Instrument Panel Passenger Airbag	1
04006-66108*	Front Pillar Garnish Kit	1

*The kit contains 2 clips

OR

Part Number	Part Description	Quantity
04007-06353	Instrument Panel Passenger Airbag Inflator Kit* Please reference inflator technical instructions for R&R procedure	1

*The kit above includes the following parts.

Part Number	Part Description	Quantity
-	Inflator	1
-	Self-locking Nut	5
-	Position Determining Plate	1

04006-66108*	Front Pillar Garnish Kit	1
--------------	--------------------------	---

*The kit contains 2 clips

Non-Desiccated Part Recovery

Dealers should discontinue the installation of the non-desiccated parts listed below for recall, customer pay repairs AND over-the-counter sales (if applicable).

Model	Model Year	Part Number	Part Description
IS 250 – IS 350, IS-F and IS 250C – IS350C	2006-2013	73960-53020 73960-53060	AIR BAG ASSY, INSTR PNL PASS L/DOOR

Lexus requires all dealers to return any parts listed above that still remain in dealer inventory by utilizing the Hazmat Part Return Program available. Dealers will be issued a refund for all part returns. This part return program is outlined in *PANT Bulletin 2014-042*.

Important Note:

In order to return the inflator, packages must **NOT** be opened/tampered with.

B. TOOLS & EQUIPMENT

- Standard hand tools
- Torque wrench
- Techstream
- Molding remover set

GLG/GLH/HLA CAMPAIGN TOOLS – These tools were previously provided to the dealership for campaign DLC and will be used for campaign ELG. These tools are required when performing this repair.

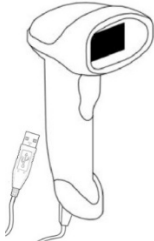
Image	Name	Quantity
	Barcode Scanner	1

NOTE: This tool **CANNOT** be ordered through the parts or tools system. There is a very limited supply of tools, but if additional tools are needed, contact your area representative.

SST –These are essential service tools that the dealership should have.

Part Number	Part Name	Quantity
09950-50013	Puller C Set *	1
* The set above includes the following tools.		
Part Number	Part Name	Quantity
09951-05010	Hanger 150	1
09952-05010	Slide Arm	2
09953-05020	Center Bolt 150	1
09954-05021	Claw No. 2	2

V. SAFETY PRECAUTIONS

STOP

CRITICAL INFORMATION – READ THOROUGHLY

STOP

Failure to follow these procedures correctly could cause the SRS to unexpectedly deploy during servicing or the SRS may fail to operate correctly when required after reassembly. Confirm all work is performed as described in these instructions.

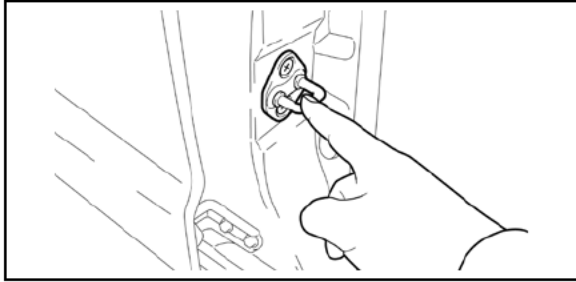

1. ELIMINATE STATIC ELECTRICITY

- a) Before starting work and periodically while working on the vehicle, touch a metallic part of the vehicle to discharge static electricity in the body.

NG DO NOT measure resistance.

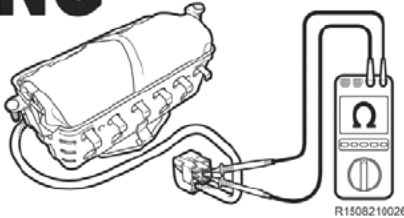

2. DO NOT MEASURE RESISTANCE

- a) **DO NOT** measure resistance of airbag components, this may cause accidental activation.

NG Replace with new one.

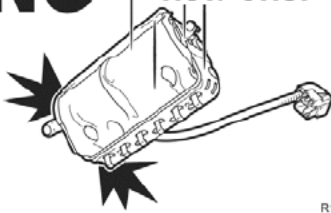

3. HANDLE THE AIRBAG CAREFULLY

- a) If an inflator is dropped, replace it with a **NEW** inflator.

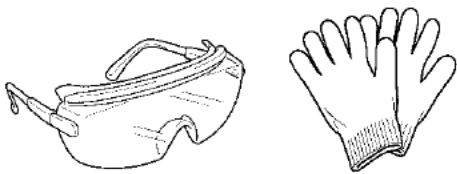

Wear protective eye wear and work gloves.

4. WEAR PROTECTIVE EQUIPMENT

- a) Always wear appropriate protective equipment when working on the SRS.

VII. FRONT PASSENGER AIRBAG REMOVAL COMPONENTS

for Automatic Transmission:

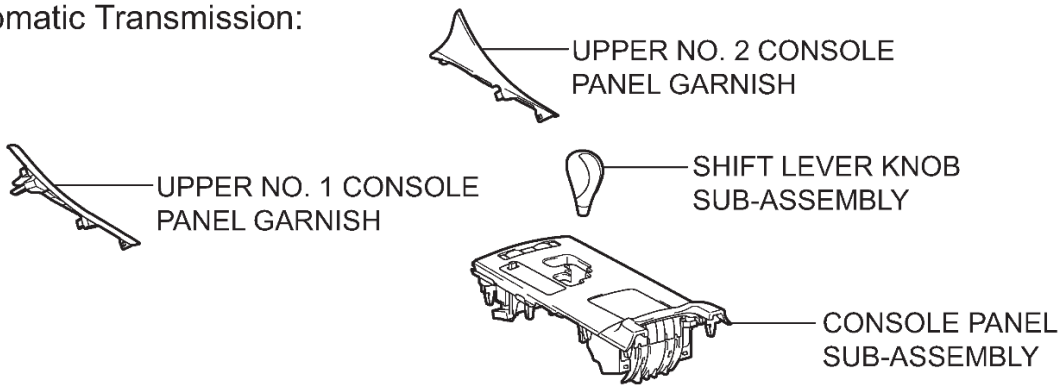

for Manual Transmission:

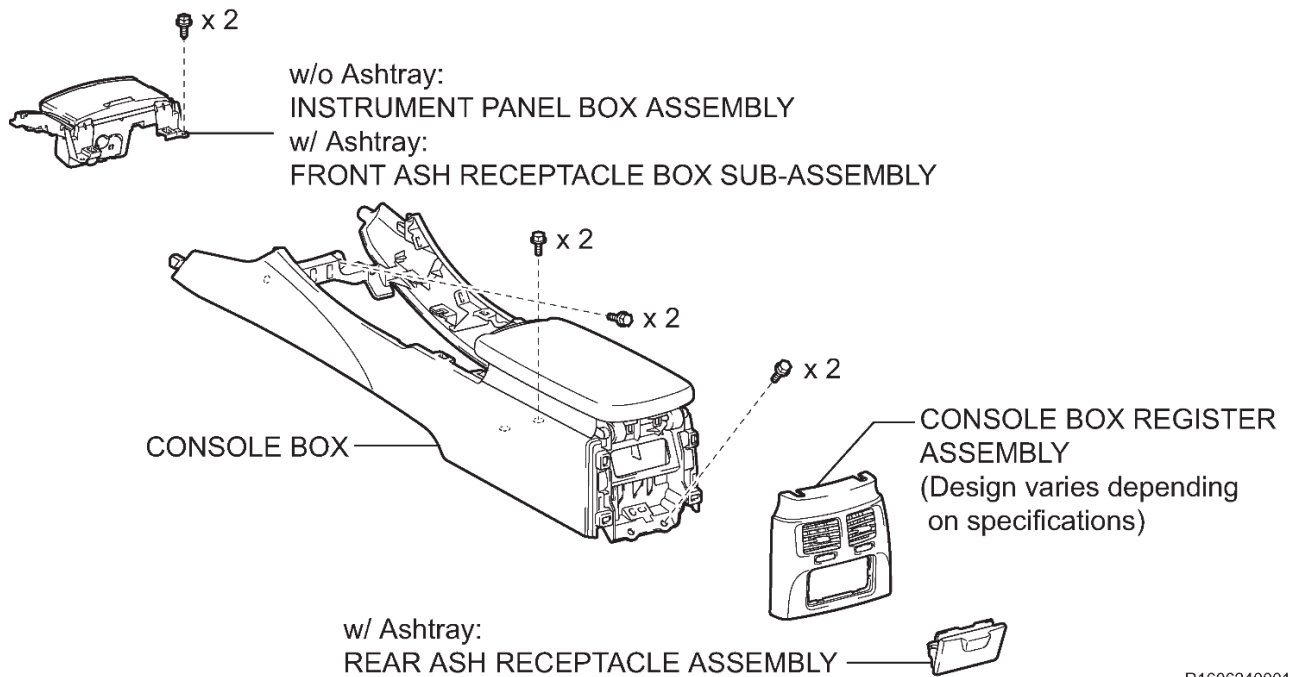
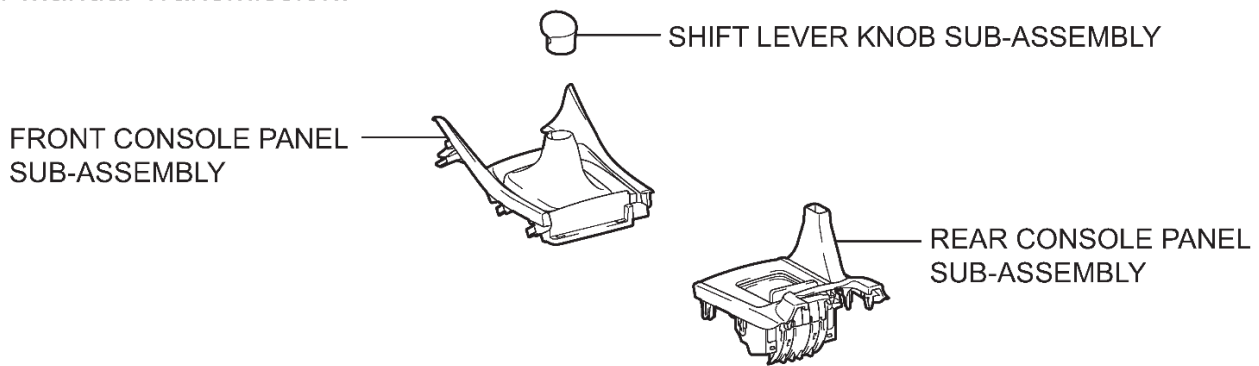

R1606240001



NO. 3 INSTRUMENT PANEL SPEAKER PANEL SUB-ASSEMBLY

w/ Front Center Speaker:

FRONT STEREO COMPONENT SPEAKER ASSEMBLY

x 2



● FRONT PILLAR GARNISH CLIP

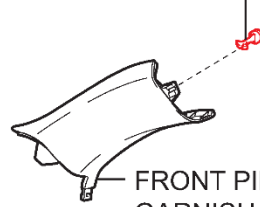

FRONT PILLAR GARNISH RH

● FRONT PILLAR GARNISH CLIP

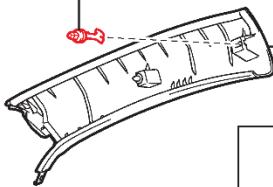

FRONT PILLAR GARNISH LH

INSTRUMENT PANEL CLIP

INSTRUMENT PANEL STAY

INSTRUMENT PANEL SAFETY PAD ASSEMBLY

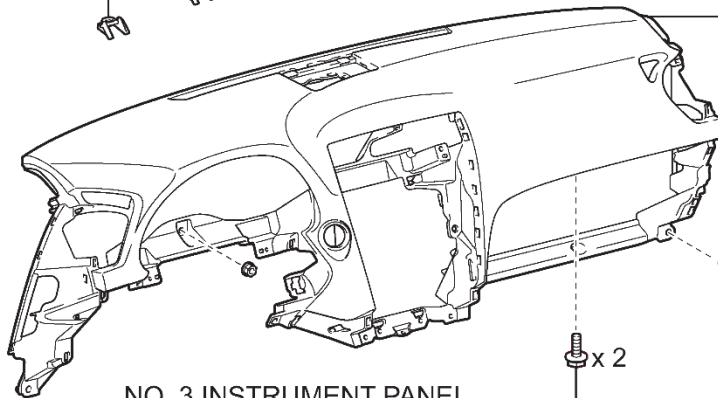

NO. 3 INSTRUMENT PANEL REGISTER ASSEMBLY

x 2

20 (204, 15)

NO. 2 INSTRUMENT PANEL REGISTER ASSEMBLY

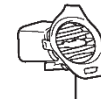

x 6



NO. 1 INSTRUMENT PANEL REGISTER ASSEMBLY

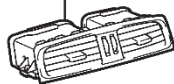

x 4

INTEGRATION CONTROL PANEL or MULTI-DISPLAY or DISPLAY AND NAVIGATION MODULE DISPLAY WITH RADIO RECEIVER ASSEMBLY



CENTER LOWER INSTRUMENT CLUSTER FINISH PANEL

NO. 1 CONSOLE BOX DUCT



for Manual Transmission:



NO. 2 CONSOLE BOX DUCT

for Automatic Transmission:

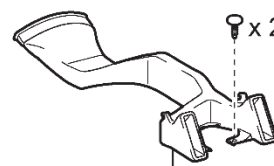

NO. 2 CONSOLE BOX DUCT

● Replacement part

N*m (kgf*cm, ft*lbf) : Specified torque

R1702150003

1. DISCONNECT THE NEGATIVE BATTERY TERMINAL



- Wait at least 90 seconds after disconnecting the cable from the negative battery terminal to prevent airbag and seat belt pre-tensioner deployment.
- Follow all precautions as outlined on TIS before servicing the SRS system.

2. INSTRUMENT PANEL PRECAUTIONS AND REMOVAL



Prior to dash removal make note of the following precautions. Over time some dash components could be easily damaged if not carefully removed.

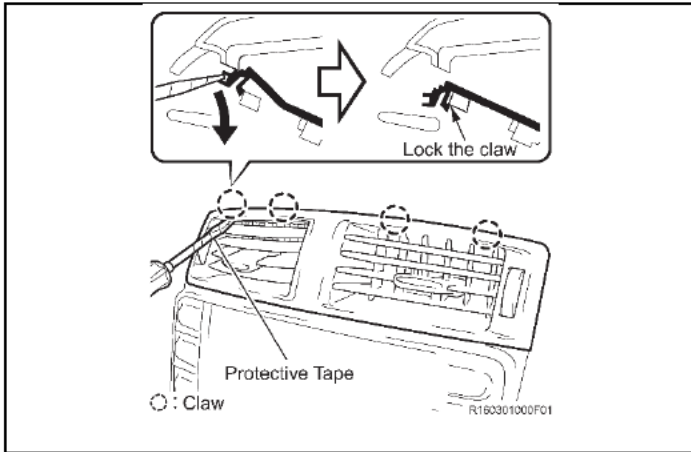

Removing the No. 3 air register

Remove any peripheral parts on left and right side of the register to allow access to the back of the register.

Wrap the tip of a screwdriver with tape.

Lock the 4 claws inside the register as shown.

NOTE: Do not use a molding removal tool to remove the register it could be damaged.

NG Do not use a molding remover

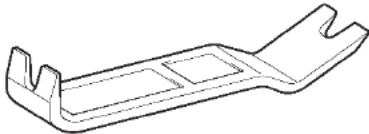

R1906160061F01

NG Do not push connector or wire harness

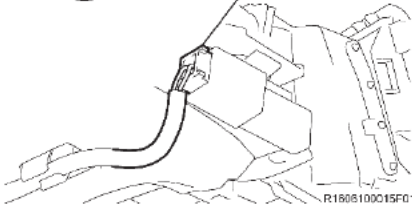

R1808100015F01

NOTE: When removing the register DO NOT push on the connector or wiring as it could be damaged.

You will remove the register by pushing from the back.

【Example for removal of center register】

OK Push from the back side

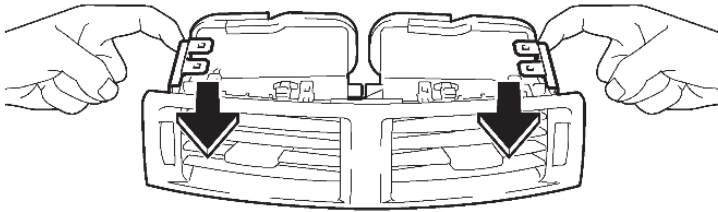

NG Pry from the front side

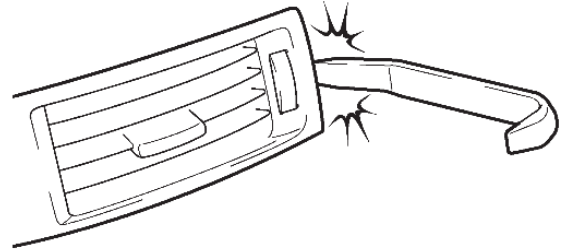

R1606130005F01

Using your finger on the left side push out at the point shown to disengage the 4 claws.

Back side of part manufactured
before August 2008:

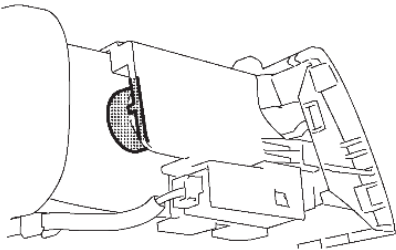

Back side of the part manufactured
after August 2008:

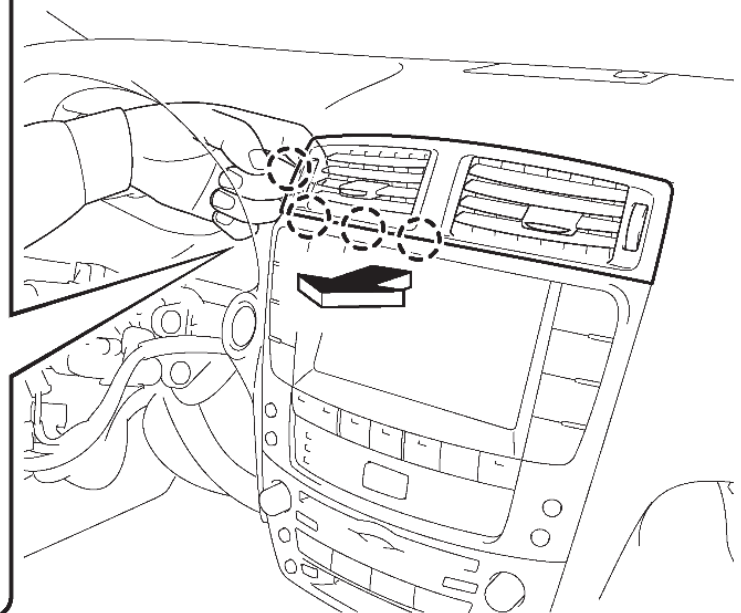
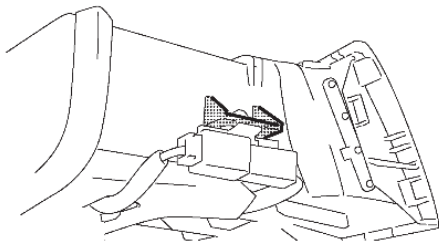

○ : Claw

R1606100013F01

Using your finger on the right side push out at the point shown to disengage the 3 claws and remove the register from the instrument panel.

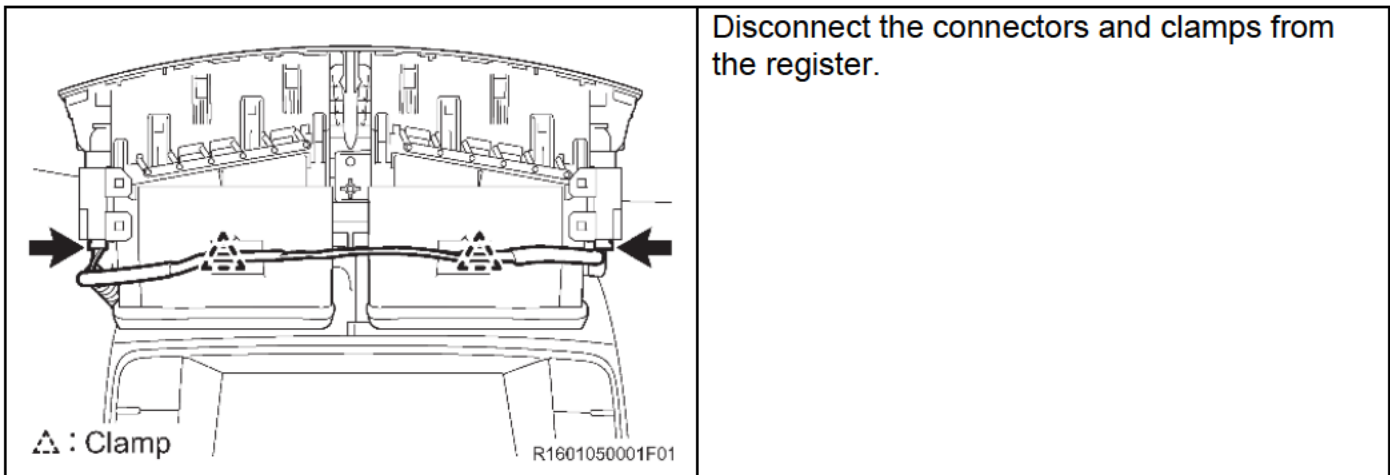
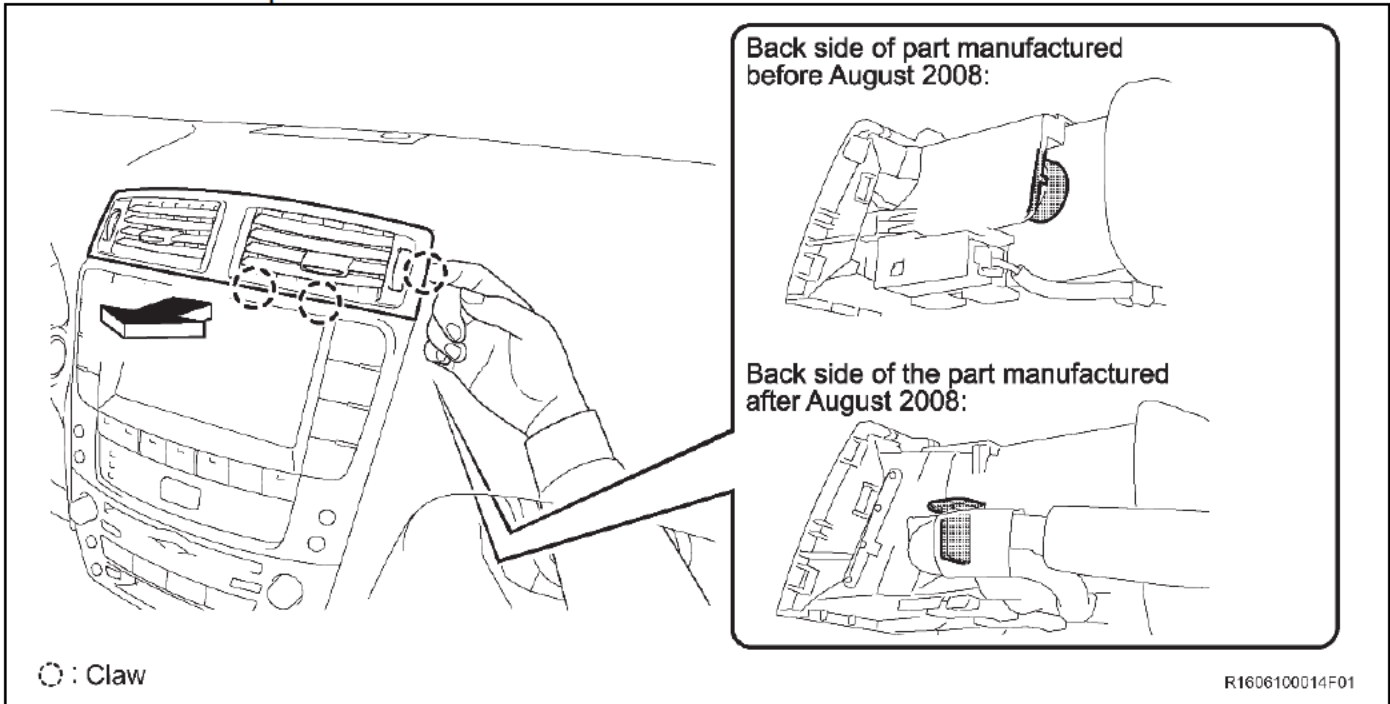

NOTE: DO NOT contact the positioning tabs while removing the instrument panel as the panel could be damaged.

a) Refer to TIS for removal instructions

IS 250/350	2006 MY	2007 MY	2008 MY	2009 MY	2010 MY	2011 MY	2012 MY	2013 MY
IS F	2008 MY	2009 MY	2010 MY	2011 MY	2012 MY	2013 MY		

3. REMOVE THE AIRBAG FROM THE DASH

- a) Remove the 3 screws and the side defroster nozzle.
- b) Remove the 2 screws and the heater to register duct.

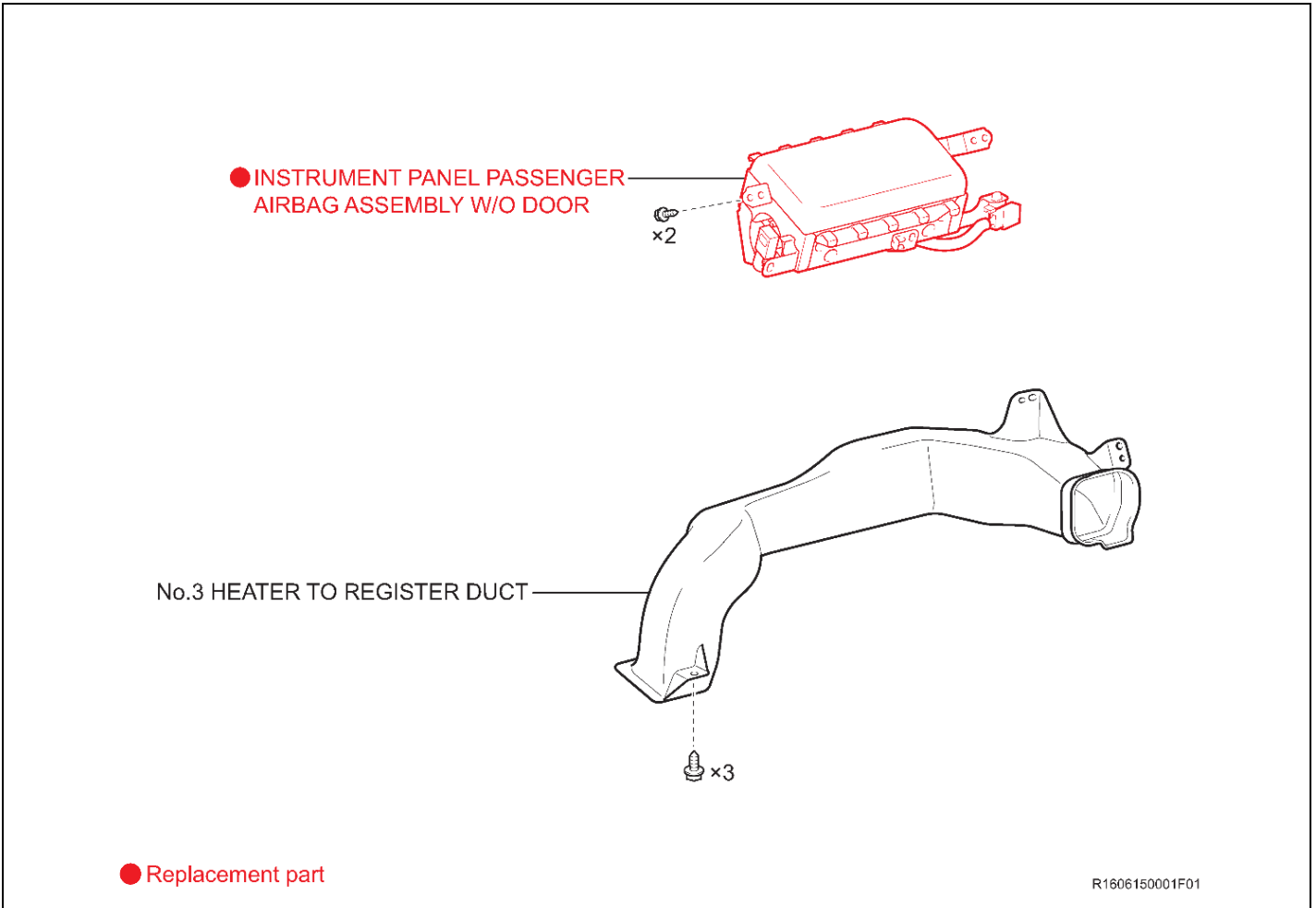

- c) Remove the 4 bolts, disengage the straps, and then remove the airbag assembly.

NOTE: Use a screwdriver with the tip wrapped in tape to remove the airbag from the dash.

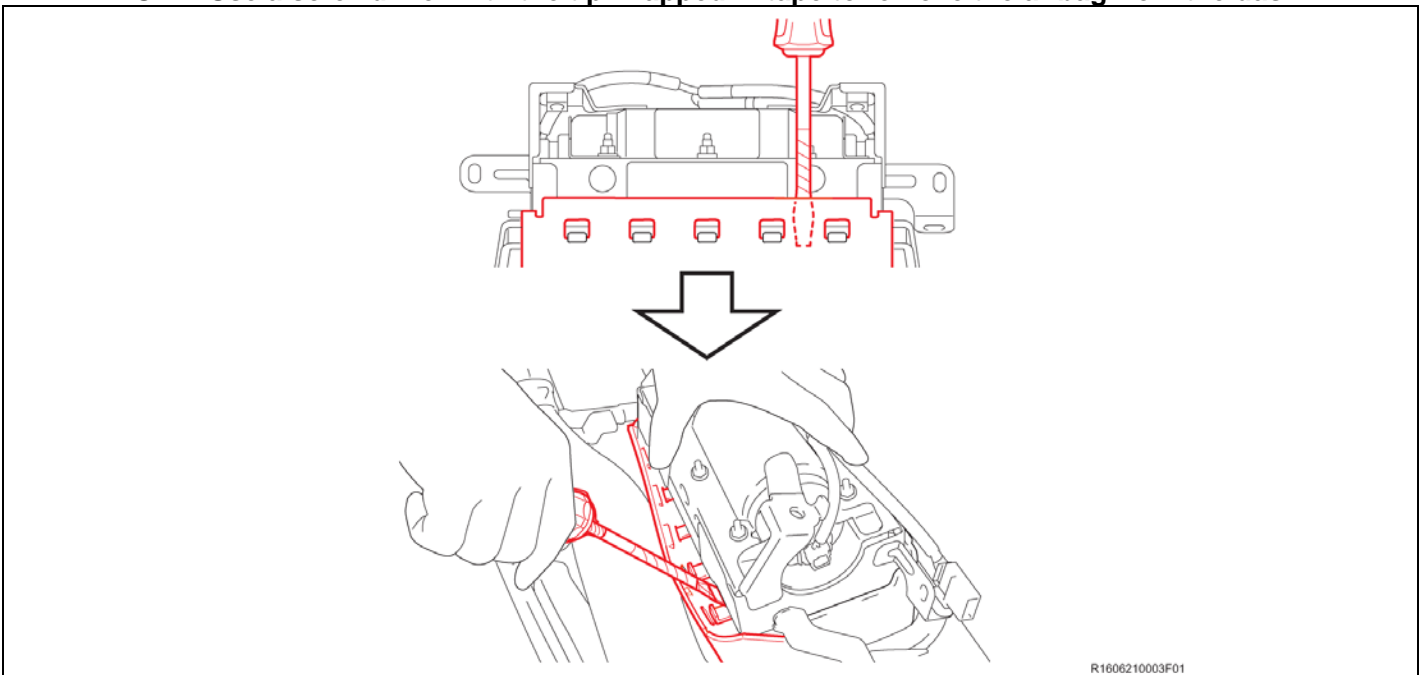

VIII. AIRBAG RECORDING

1. LAUNCH THE SERIAL NUMBER RECORDING APPLICATION

Note: The Serial Number Recording Application is the same application used for DLC.



- The AIRBAG ASSEMBLY serial numbers **MUST** be recorded using a barcode scanner (provided at the launch of SSC DLC).
- The barcode scanner application **MUST** be completed on every vehicle. These numbers **MUST** be included on every warranty claim that is submitted for airbag module replacement or the claim may be subject to debit.
- The technician performing the work **MUST** have valid TIS login credentials and an internet connection to perform the inspection and scanning process.

- a) Log in to TIS and input the VIN of the vehicle in the Vehicle Inquiry tab.
- b) Confirm the VIN is applicable and that the campaign has not been completed.
- c) Click on the link to launch the serial number recording application.

The screenshot shows the Toyota TIS interface. At the top, there are navigation tabs: Home, TIS, TAS, PRS, QAT, and TOYOTA. Below these are sub-tabs: Library, Diagnostics, Tech Assistance, and Vehicle Inquiry. The 'Vehicle Inquiry' tab is active, showing a 'Vehicle Identification Number Search' section with a text input field containing '1NX-BR32E-000000000' and 'Clear' and 'Lookup' buttons. Below this is the 'Vehicle Information' section with fields for Division (TOYOTA), Model (Corolla), Grade (CE), Model Year (2003), Drive Type (2WD), Body Type (4Dr. Sedan), Engine Family (4-cylinder - 1ZZ), Transmission, Date of First Use, Production Date (01/10/2002), Plant Code (Z - FREMONT PLANT - NUMMI), VIN (1NX-BR32E-000000000), and Standard Equipment. Below this is the 'Service Campaign' section with a 'Campaign Description' and 'Completion Status: Not Completed'. A red circle highlights the 'Check applicability for VIN' link.

- d) Reenter TIS password in the serial number recording application.

NOTE: The person logged-in to TIS **MUST** be the person performing the repair.

The screenshot shows the 'Front Passenger Airbag Inflator Module - Safety Recall' application. The title is 'SSC - DSF'. The user is 'Suzuki' and the technician is 'Russell Suzuki'. The dealer code is '06/10/2014 02:07 PM PDT'. The original inflator serial number is 'STD 87444-01000' and the replacement inflator serial number is '87444-01000'. The VIN is '1NX-BR32E-000000000'. The 'Message' field is empty. Below this is a table with columns: Task, Dealer, User, Time, Status. The table contains three rows: 'Airbag # Record', 'Inflator # Record', and 'Recall # Conditions'. All three rows have a status of 'Not Started'.

- e) Record the vehicle mileage into the serial number recording application.

NOTE:

- A task status screen will populate next and at other intervals during the repair. This screen will indicate if the inflator was replaced or in some limited cases that the entire airbag assembly was replaced. Click 'next' to proceed to the next step. This information will be used for record keeping by TMS.
- If this screen indicates that the campaign has already been completed on this VIN, there is no need to perform the campaign again.

2. CONNECT THE BARCODE SCANNER

- Connect the barcode scanner to the USB port on the Techstream.
- The scanner will automatically connect and a beep will be heard when the scanner is ready.

NOTE:

- The scanner was provided for SSC DLC.
- The barcode scanner works best in low light conditions.
- Always hold the scanner directly in front of and parallel to the barcode label.

3. SCAN THE AIRBAG SERIAL NUMBER

ATTENTION: This information is **CRITICAL**

- Scan the **AIRBAG ASSEMBLY** serial number 2 times.
 - Confirm the cursor is in the first serial number box then scan the serial.
 - Position the cursor in the second serial number box then scan the serial.
- Click next.

NOTE:

- If both serial numbers that are entered do not match, confirm and reenter.
- If the serial number barcode will not scan, it can be entered manually.

AIRBAG SERIAL NUMBER IDENTIFICATION

- The airbag serial number is **ALWAYS** the **12 DIGITS** located between the asterisks.
- The 3 digits before the asterisk **ARE NOT** part of the serial number, and **SHOULD NOT** be entered or an inaccurate response may be returned.

Airbag Serial Number Label Example



The **AIRBAG ASSEMBLY** serial number **MUST** be recorded prior to replacement.

Front Passenger Airbag Inflator Module - Safety Recall

SSC DSC

1 2 3 4 5

User ID: Technician Name:

Dealer Code: Dealer Name:

Time: 03/30/2015 05:15 AM PDT VIN: [rolla SUPER WHITE]

Original Airbag Module - 12 Digits
Between the asterisk (*) symbols

Record Airbag Serial Number

How to Identify an Airbag module Assembly number?

The Airbag module Assembly serial number is a 12 digit code. It can be found along with a bar code on opening the Airbag assembly unit. To manually enter these details into the application, the technician has to identify the 12 digit code between two Asterisks (*) inside the Airbag assembly unit. The first seven characters of this 12 digit code are numbers and the 10th digit is either 'K' or 'L' always.

Use of a barcode scanner is strongly recommended when entering Airbag Assembly Serial Number.

If manually typing serial number, you MUST include all leading zeros. (If applicable)

* Airbag Assembly Serial Number:

* Reconfirm Airbag Assembly Serial Number:

If original Airbag Assembly serial number is not visible or missing, check this box

Clear Next

(*) - Indicates Required Field(s)



- c) **Check the box that states that the inflator serial number is not visible or missing.
(DO NOT SCAN THE INFLATORS)
(this will allow the program to advance to the next screen)**

Front Passenger Airbag Inflator Module - Safety Recall
SSC - E04

User ID: _____
Dealer Code: _____
Time: 03/30/2015 05:17 AM PDT
VIN: [2004 Corolla SUPER WHITE]
Technician Name: _____
Dealer Name: _____
Airbag Serial #: *****12

Original Inflator

How to identify the Inflator serial code on the Original and Replacement Inflator can?
The Inflator serial code is an **11 digit code** on the inflator can. It can be found with a bar code on removing the Inflator can from the Airbag Assembly unit.
The first two characters of the **Original Inflator Serial code** will be from [AA, AB, AJ, FD or JD].
The first two characters of the **Replacement Inflator Serial code** will be either 'LT' or 'LR'.

Replacement Inflator

Inflator Module replacement IS REQUIRED on all vehicles under the Safety Recall. Follow the technical instructions and acknowledge the following statements.
If manually typing serial number, you MUST include all leading zeros. (Applicable)
Original Inflator Serial #:
If old inflator serial number is not visible or missing, check this box.
* Replacement Inflator Serial #:

If you have a concern with the inflator serial numbers, please email quality_compliance@toyota.com with details.

I agree to complete the safety recall's remaining technical instructions.
 I agree to perform a vehicle Health Check with Techstream upon completion of the safety recall's technical instructions.

(*) - Indicates Required Field(s)

Back Clear

- d) Confirm agreement by checking the two boxes and press submit.

NOTE: The NEW AIRBAG ASSEMBLY serial number MUST be scanned prior to reinstallation to track the airbag to the vehicle (refer to page 16).

e) Scan the new Airbag barcode in the Serial Number Recording Application.

Front Passenger Airbag Inflator Module - Safety Recall

SSC DSC

1 2 3 4 5

User ID: _____ Technician Name: _____
Dealer Code: _____ Dealer Name: _____
Time: 03/30/2015 05:15 AM PDT VIN: [2004 Corolla SUPER WHITE]

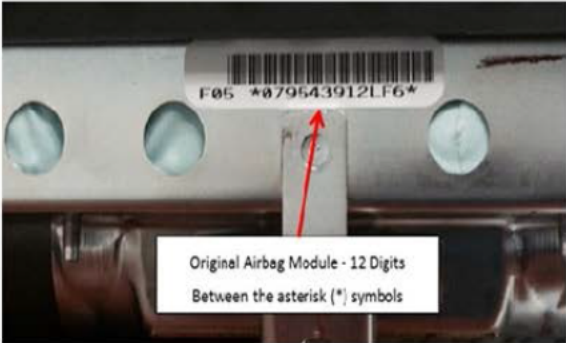

Record Airbag Serial Number

Use of a barcode scanner is strongly recommended when entering Airbag Assembly Serial Number.

If manually typing serial number, you MUST include all leading zeros. (If applicable)

*New Airbag Assembly Serial Number:

[How to Identify an Airbag module Assembly number?](#)

The Airbag module Assembly serial number is a **12 digit code**. It can be found along with a bar code on opening the Airbag assembly unit. To manually enter these details into the application, the technician has to identify the 12 digit code between two Asterisks (*) inside the Airbag assembly unit. The first seven characters of this 12 digit code are numbers and the 10th digit is either 'K' or 'L' always.

I agree to complete the safety recall's remaining technical instructions.

I agree to perform a vehicle Health Check with Techstream upon completion of the safety recall's technical instructions.

(*) - Indicates Required Field(s)

f) Confirm agreement by checking the two boxes and press next.



The new **AIRBAG ASSEMBLY** serial number **MUST** be recorded prior to reinstallation to track the airbag assembly to the vehicle.

g) Record the Warranty Authorization # to be included in the warranty claim.

T3 :: SuzukiR - Google Chrome
t3qa.tms.toyota.com/t3Portal/portlets/tis/airBag/AirBagController.portlet?_nfpb=true&_windowLabel=Standal

Front Passenger Airbag Inflator Module - Safety Recall

SSC - DSF

1 2 3 4 5

User ID: SuzukiR **Technician Name:** Russell Suzuki
Dealer Code: **Dealer Name:**
Time: 06/10/2014 05:13 PM PDT **Airbag Serial #:** *****96
Original Inflator Serial #: AAEL5110212 **Replacement Inflator Serial #:** AAEL5110213

SuzukiR has agreed to the following terms and conditions on 06/10/2014 05:13 PM PDT

- * I agree to complete the safety recall's remaining technical instructions.
- * I agree to perform a vehicle Health Check with Techstream upon completion of the safety recall's technical instructions.

Russell Suzuki has successfully confirmed completion of Airbag Inflator Module Safety Recall for

VIN - [2003 Sequoia BEIGE M. M.]

Warranty Authorization #: b5511e9f

Airbag inflator module was replaced under this safety recall.

Print this page for your records and then click 'Close' to resume working.

Close

h) Confirm agreement by checking the two boxes.

i) Place the old airbag in the parts box and return it to the parts department.

NOTE:

- Keep all shipping paperwork with the box that it came in.
- Confirm the cursor is in the correct serial number input box before scanning.
- If the serial number barcode will not scan, it can be entered manually.
- If there are any difficulties or concerns with this process, email quality_compliance@toyota.com with details.

AIRBAG SERIAL NUMBER IS MISSING OR IS UNREADABLE



If the airbag serial number and barcode are not legible or are not present, check the box in the application indicating the serial number is not legible.

a) If the airbag serial number cannot be scanned or is not present check the box as shown below.

Front Passenger Airbag Inflator Module - Safety Recall
SSC DSC

(1) (2) (3) (4) (5)

User ID: _____ Technician Name: _____
Dealer Code: _____ Dealer Name: _____

Time: 03/30/2015 05:15 AM PDT VIN: 2004 Corolla SUPER WHITE]

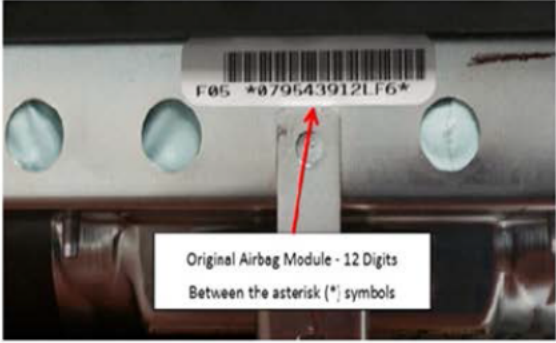

Record Airbag Serial Number

[How to Identify an Airbag module Assembly number?](#)

The Airbag module Assembly serial number is a 12 digit code. It can be found along with a bar code on opening the Airbag assembly unit. To manually enter these details into the application, the technician has to identify the 12 digit code between two Asterisks (*) inside the Airbag assembly unit. The first seven characters of this 12 digit code are numbers and the 10th digit is either 'K' or 'L' always.

Use of a barcode scanner is strongly recommended when entering Airbag Assembly Serial Number.
If manually typing serial number, you MUST include all leading zeros. (If applicable)

* Airbag Assembly Serial Number:

* Reconfirm Airbag Assembly Serial Number:

If original Airbag Assembly serial number is not visible or missing, check this box

Clear Next

(*) - Indicates Required Field(s)

Check this box if the Airbag serial number is not legible.

b) Return to Page 14 and continue.

IX. VEHICLE REASSEMBLY

1. REINSTALL THE AIRBAG ASSEMBLY INTO THE INSTRUMENT PANEL

- a) Position the airbag assembly in the instrument panel, engage the straps, and then install the 4 bolts.

NOTE: Ensure the airbag connectors is positioned as shown

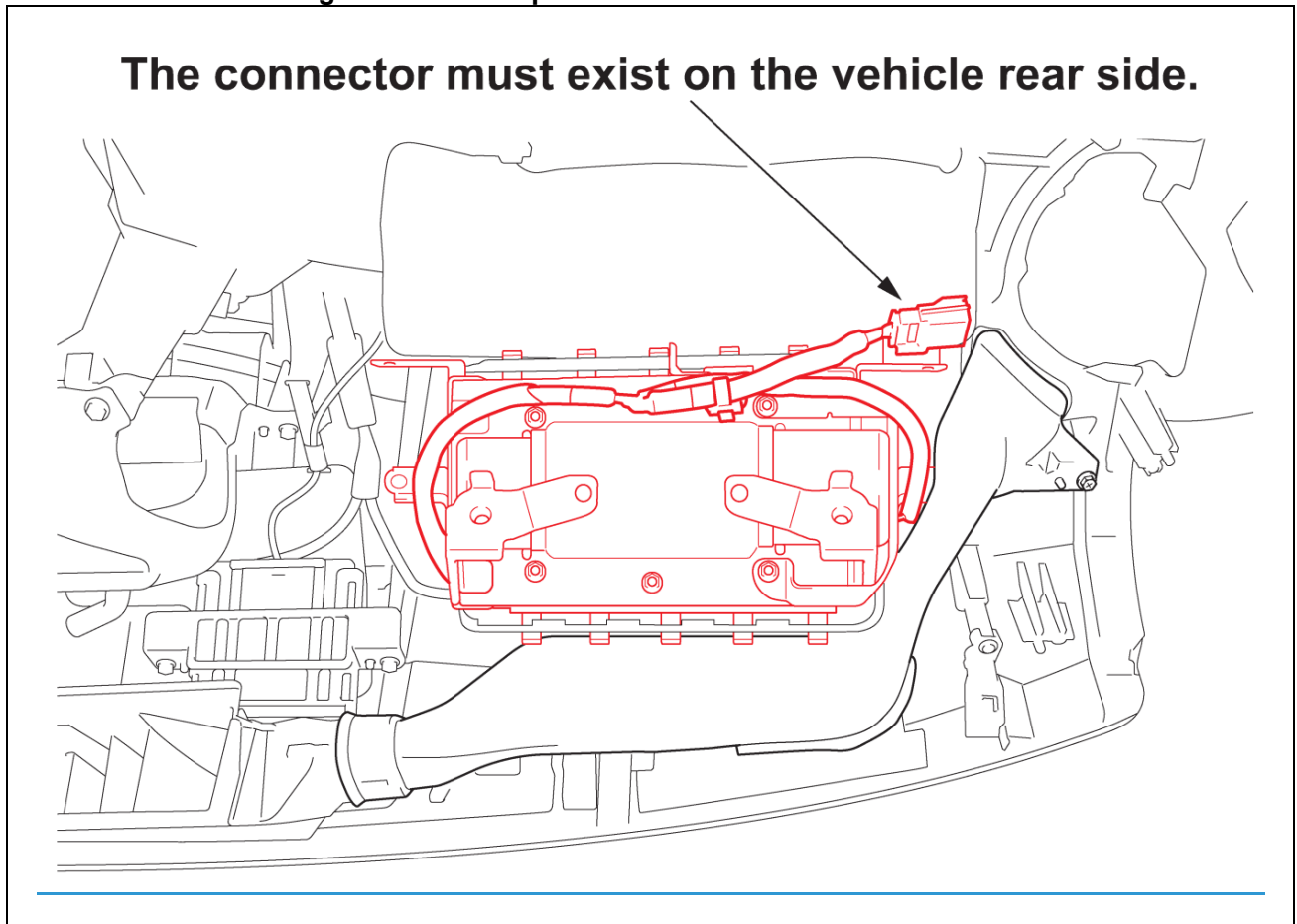

- b) Install the 2 screws and the heater to register duct.
- c) Install the 3 screws and the side defroster nozzle.

2. REINSTALL THE DASH

a) Refer to TIS for reinstallation instructions

IS 250/350	2006 MY	2007 MY	2008 MY	2009 MY	2010 MY	2011 MY	2012 MY	2013 MY
IS F	2008 MY	2009 MY	2010 MY	2011 MY	2012 MY	2013 MY		

3. RECONNECT THE NEGATIVE BATTERY CABLE
4. PERFORM A HEALTH CHECK AND DIAGNOSTIC REPORT
5. PERFORM ANY NEEDED SYSTEM INITIALIZATIONS

◀ VERIFY REPAIR QUALITY ▶

- Confirm all precautions are followed to ensure safety during the repair
- Confirm the entire serial number checker application is completed and the warranty authorization # is recorded on **EVERY** vehicle
- Confirm the old airbag is handled safely and given to the appropriate parts professional for shipment

If you have any questions regarding this update, please contact your area representative.

X. APPENDIX

A. CAMPAIGN DESIGNATION DECODER

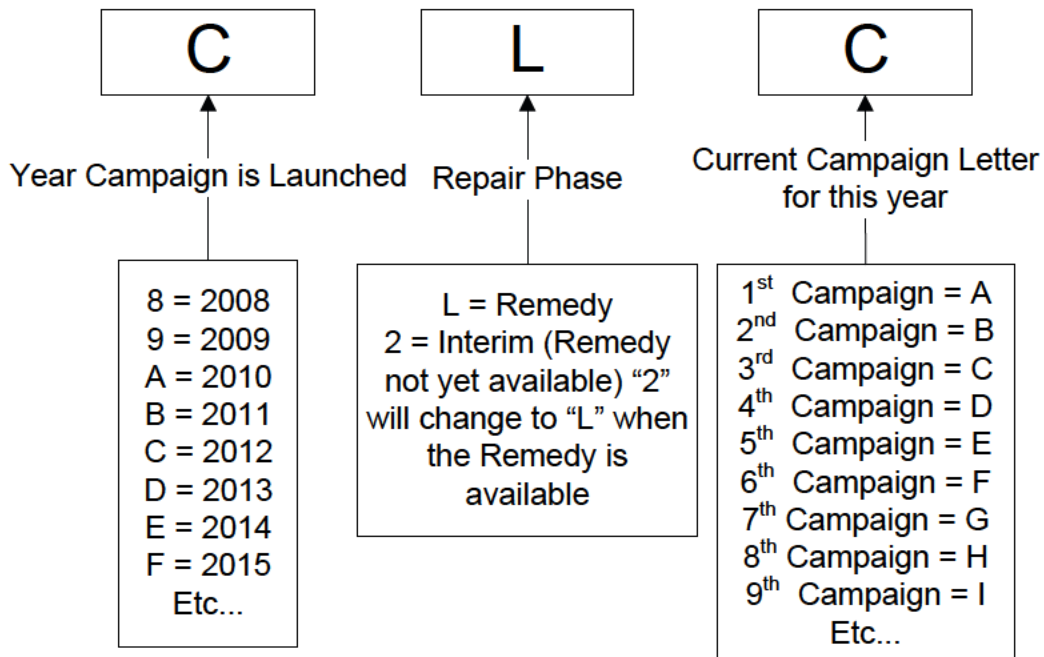

B. CAMPAIGN PARTS DISPOSAL

ALL airbags that are removed from vehicles under this campaign **MUST** be packaged and shipped back to the manufacturer following the manufacturer's instructions. The instructions can be found in the following locations:

- Attached to the dealer letter
- Included in the parts box