

# IMPORTANT UPDATE

## TECHNICAL INSTRUCTIONS FOR SAFETY RECALL GLG/GLH/HLA FRONT PASSENGER AIRBAG INFLATOR REPLACEMENT CERTAIN 2007 – 2012 MY ES 350

**Updated 01-14-2021**

**Update 01-14-21**

- **The scanning application process has been updated**

**Update 1-15-19**

- **The parts section has been updated**

**Update 1-9-19**

- **The title has been updated to include GLH and HLA**

**Update 4-18-18**

- **The parts section has been updated**

**The repair quality of covered vehicles is extremely important to Lexus. All dealership technicians performing this recall are required to successfully complete the most current version of the E-Learning course “Safety Recall and Service Campaign Essentials”. To ensure that all vehicles have the repair performed correctly:**

- **MASTER SERVICE TECHNICIANS**
- **MASTER DIAGNOSTIC SPECIALISTS**

**It is the dealership’s responsibility to select technicians with the above certification level or greater to perform this recall repair. Carefully review your resources, the technician skill level, and ability before assigning technicians to this repair. It is important to consider technician days off and vacation schedules to ensure there are properly trained technicians available to perform this repair at all times.**

**NOTE: To support additional service capacity, Lexus Certified and Senior Service Technicians, with at least 36 months Lexus experience AND L652 course credit, may also perform this repair following successful completion of course LSC13B.**

## I. OPERATION FLOW CHART

The flow chart is for reference only. **DO NOT** use it in place of the full technical instructions. Follow **ALL** steps as outlined in the full technical instructions to confirm the campaign is completed correctly.

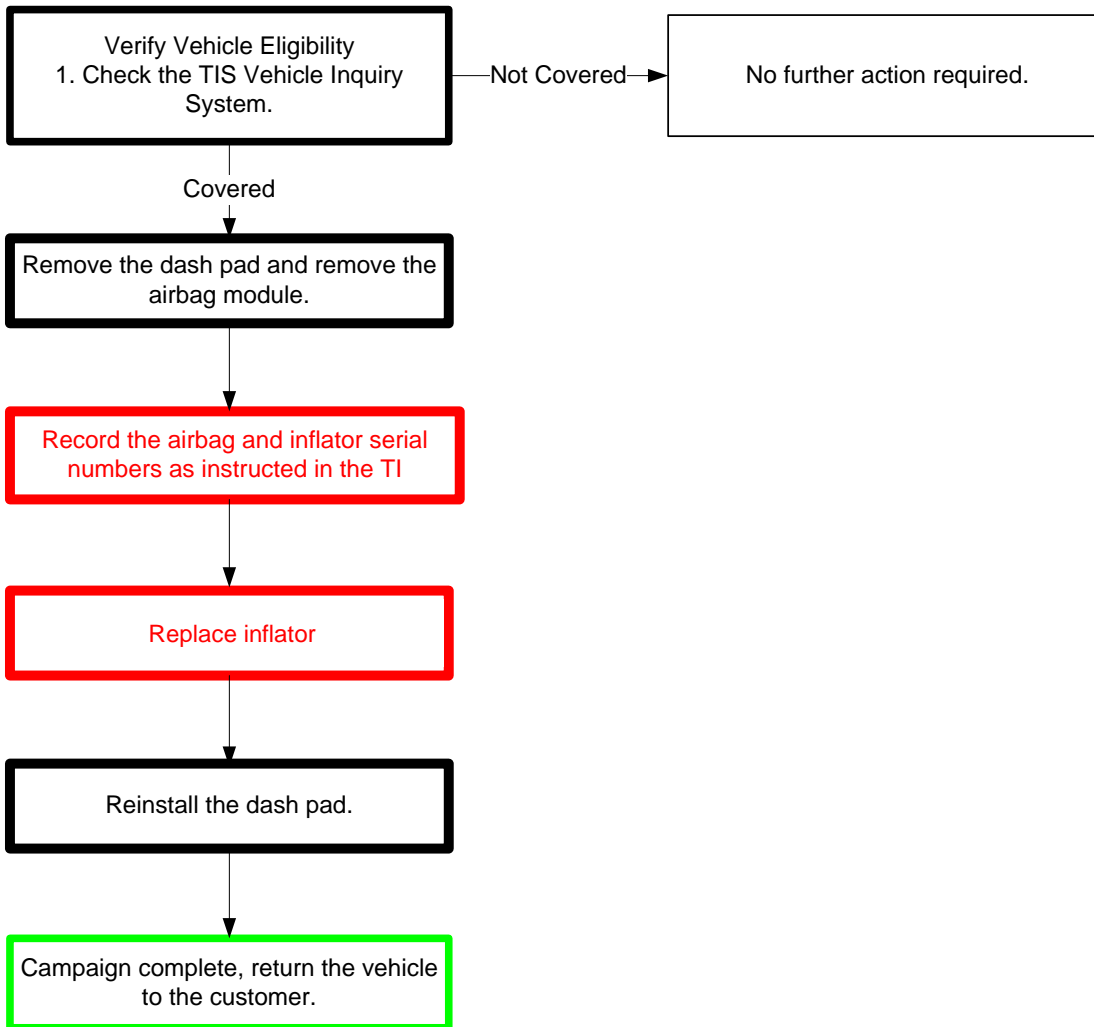

## II. BACKGROUND

The subject vehicles are equipped with front passenger airbag inflators produced by Takata. The propellant in these inflators may degrade after prolonged exposure to high absolute humidity and fluctuating high temperatures. Degraded propellant can cause inflator rupture during airbag deployment. In the event of an inflator rupture, metal fragments could pass through the airbag cushion material, striking the vehicle occupants, and result in serious injury or death.

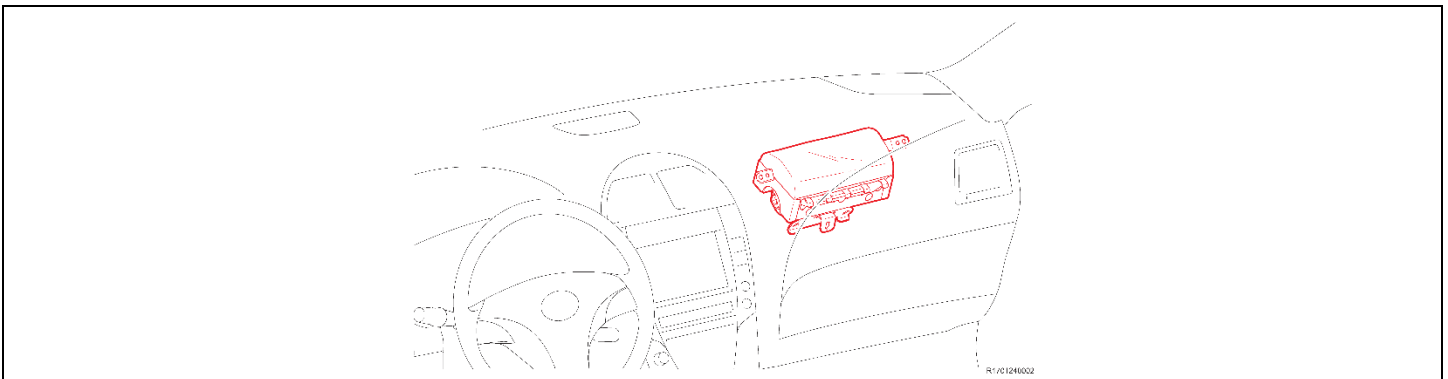

### III. IDENTIFICATION OF AFFECTED VEHICLES

#### A. COVERED VIN RANGE

- Check the TIS Vehicle Inquiry System to confirm the VIN is involved in this Safety Recall, and that the campaign has not already been completed prior to dealer shipment or by another dealer.
- **TMS warranty will not reimburse dealers for repairs conducted on vehicles that are not affected or were completed by another dealer.**

### IV. PREPARATION

#### A. PARTS

Part Number	Part Description	Quantity
04007-06733	Instrument Panel Passenger Airbag Inflator Kit	1
04006-66108*	Front Pillar Garnish Kit (*kit contains 2 clips)	1

#### Non-Desiccated Part Recovery

**Dealers should discontinue the installation of the non-desiccated parts listed below for recall, customer pay repairs AND over-the-counter sales (if applicable).**

Model	Model Year	Part Number	Part Description
ES350	2007-2012	73960-33110 73960-33111	AIR BAG ASSY, INSTR PNL PASS L/DOOR

**Lexus requires all dealers to return any parts listed above that still remain in dealer inventory by utilizing the Hazmat Part Return Program available. Dealers will be issued a refund for all part returns. This part return program is outlined in *PANT Bulletin 2014-042*.**

#### Important Note:

In order to return the inflator, packages must **NOT** be opened/tampered with.

**B. TOOLS & EQUIPMENT**

- Standard hand tools
- Torque wrench
- Techstream
- Molding remover set

**GLG/GLH CAMPAIGN TOOLS** – These tools were previously provided to the dealership for campaign DLC and will be used for this campaign. These tools are required when performing this repair.

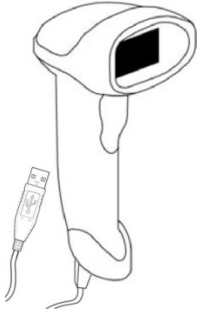
Image	Name	Quantity
	Barcode Scanner	1

**NOTE:** This tool **CANNOT** be ordered through the parts or tools system. If additional tools are needed, they can be sourced locally.

**DLC CAMPAIGN TOOLS** – These tools are required when performing this repair.

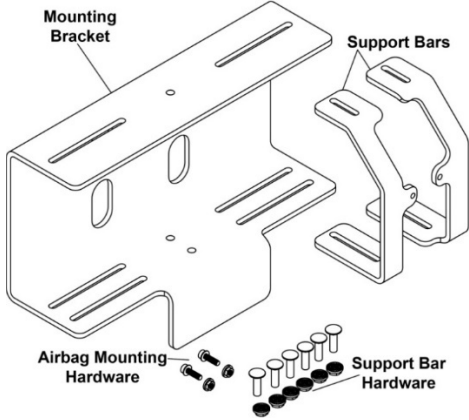
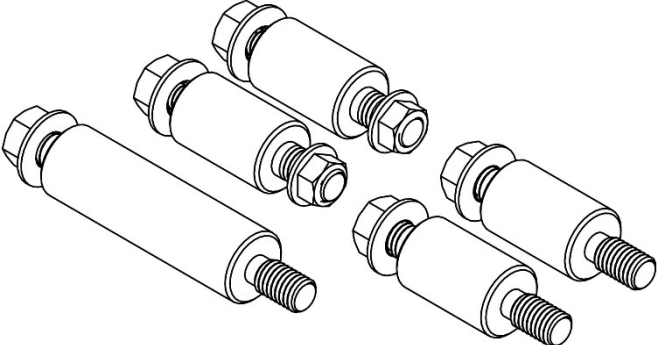
Image	Name	Quantity
 <p>Labels in image: Mounting Bracket, Support Bars, Airbag Mounting Hardware, Support Bar Hardware</p>	Airbag Mounting Bracket & hardware (Provided to the dealership at the launch of SSC DLC)	1
	579943 Adaptor set*	1

\*The adaptor set was sent to dealers prior to the start of this campaign.

**SST** –These are essential service tools that the dealership should have.

<b>Part Number</b>	<b>Part Name</b>	<b>Quantity</b>
09950-50013	Puller C Set *	1
* The set above includes the following tools.		
<b>Part Number</b>	<b>Part Name</b>	<b>Quantity</b>
09951-05010	Hanger 150	1
09952-05010	Slide Arm	2
09953-05020	Center Bolt 150	1
09954-05021	Claw No. 2	2

## V. SAFETY PRECAUTIONS



### CRITICAL INFORMATION – READ THOROUGHLY



Failure to follow these procedures correctly could cause the SRS to unexpectedly deploy during servicing or the SRS may fail to operate correctly when required after reassembly. Confirm all work is performed as described in these instructions.

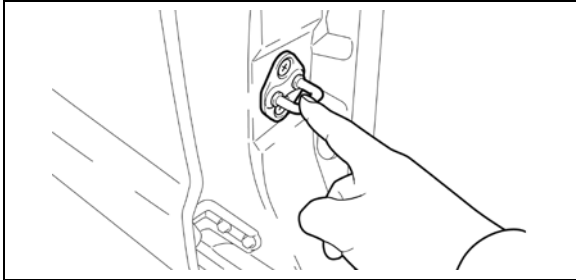

#### 1. ELIMINATE STATIC ELECTRICITY

- a) Before starting work and periodically while working on the vehicle, touch a metallic part of the vehicle to discharge static electricity in the body.



#### 2. DO NOT MEASURE RESISTANCE

- a) **NEVER** measure the resistance of an airbag, this may cause accidental activation.

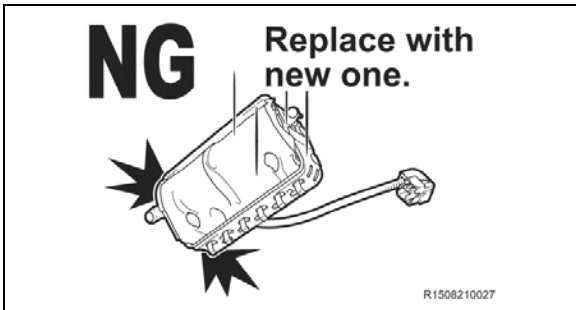

#### 3. HANDLE THE AIRBAG CAREFULLY

- a) If the airbag is dropped, replace it with a **NEW** one.

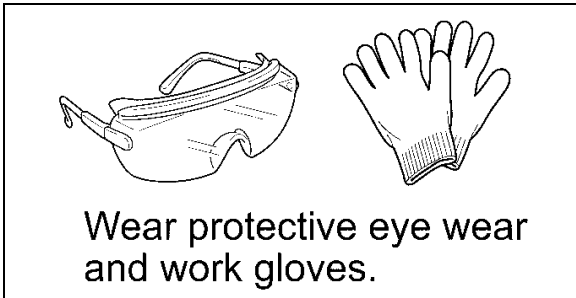

#### 4. WEAR PROTECTIVE EQUIPMENT

- a) Always wear appropriate protective equipment when working on the SRS.



# VII. FRONT PASSENGER AIRBAG REMOVAL COMPONENTS



UPPER CONSOLE PANEL ASSEMBLY WITH FRONT ASH RECEPTACLE

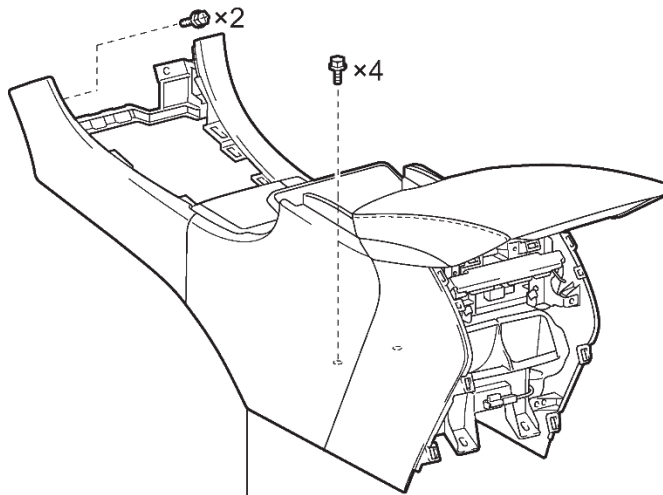
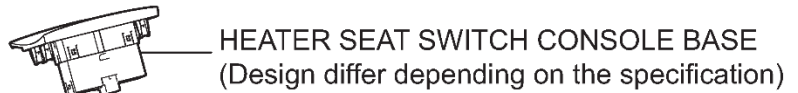
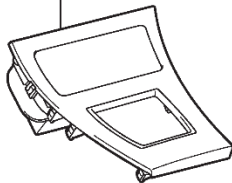

REAR CONSOLE BOX ASSEMBLY  
(Design differ depending on the specification)

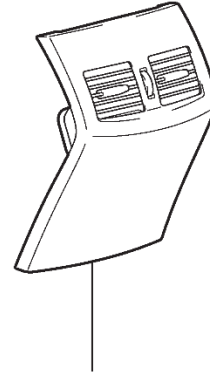

CONSOLE REAR END PANEL SUB-ASSEMBLY

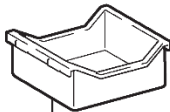

CONSOLE BOX POCKET  
(Design differ depending on the specification)

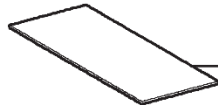

CONSOLE BOX CARPET

R1701240004

TURN SIGNAL SWITCH ASSEMBLY WITH SPIRAL CABLE SUB-ASSEMBLY

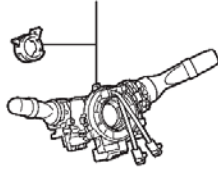

TILT AND TELESCOPIC SWITCH

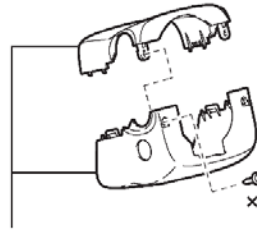

STEERING COLUMN COVER

2.0 (20, 18 in.\*lbf)

x2

COMBINATION METER ASSEMBLY

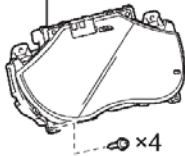

x4

STEERING WHEEL ASSEMBLY



50 (510, 37)

LOWER No. 3 STEERING WHEEL COVER

8.8 (90, 78 in.\*lbf)

LOWER No. 2 STEERING WHEEL COVER

INSTRUMENT CLUSTER FINISH PANEL SUB-ASSEMBLY

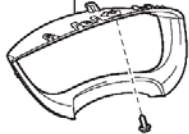

LOWER INSTRUMENT PANEL RH

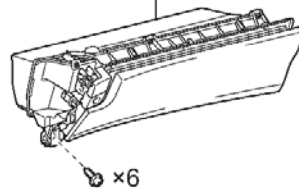

x6

STEERING PAD



SIDE INSTRUMENT PANEL LH

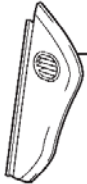

FRONT PASSENGER SIDE KNEE AIRBAG ASSEMBLY

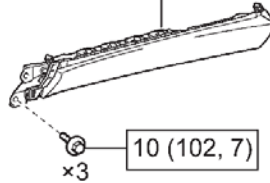

x3

10 (102, 7)

SIDE INSTRUMENT PANEL RH



No. 1 SWITCH HOLE BASE



LOWER INSTRUMENT PANEL SUB-ASSEMBLY

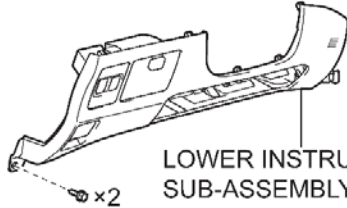

FRONT DOOR OPENING TRIM COVER RH



FRONT DOOR OPENING TRIM COVER LH



INSTRUMENT PANEL FINISH PANEL END RH



FRONT DOOR SCUFF PLATE RH

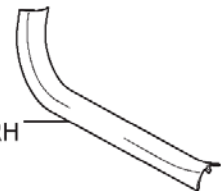

INSTRUMENT PANEL FINISH PANEL END LH



FRONT DOOR SCUFF PLATE LH

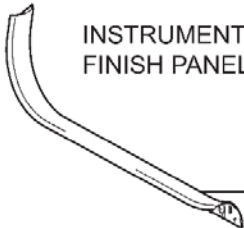

No.2 INSTRUMENT PANEL UNDER COVER SUB-ASSEMBLY

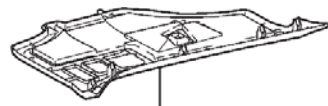

N\*m (kgf\*cm, ft\*lbf) : Specified torque

R1701240005

● FRONT PILLAR GARNISH CLIP

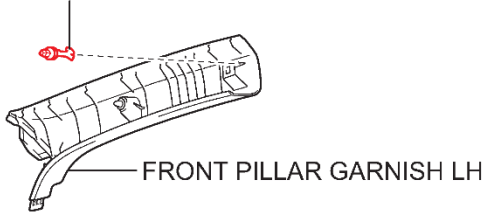

● FRONT PILLAR GARNISH CLIP

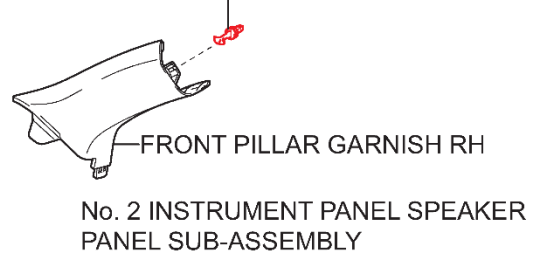

No. 1 INSTRUMENT PANEL SPEAKER PANEL SUB-ASSEMBLY

No. 1 SPEAKER HOLE COVER

INSTRUMENT PANEL SAFETY PAD ASSEMBLY

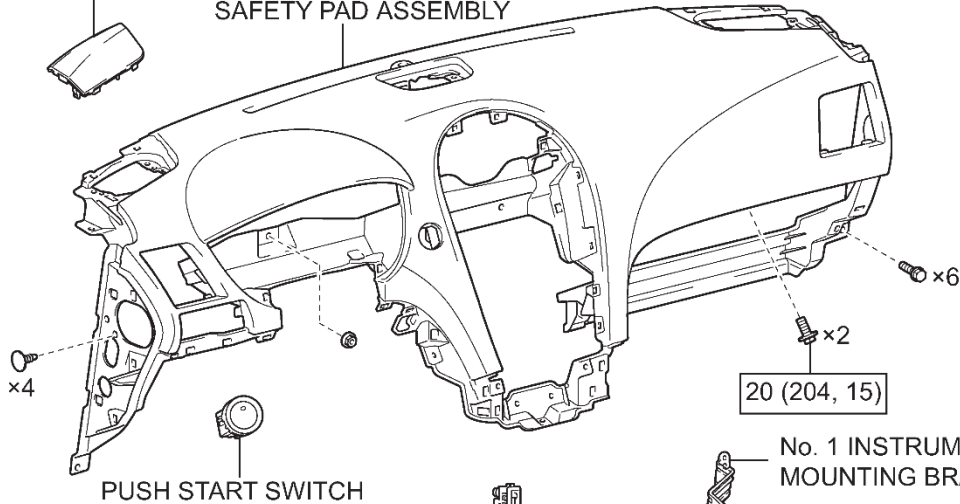

PUSH START SWITCH

ROOM TEMPERATURE SENSOR

FRONT STEREO COMPONENT SPEAKER ASSEMBLY  
(Design differ depending on the specification)

FRONT No. 2 SPEAKER ASSEMBLY  
(Design differ depending on the specification)

FRONT No. 2 SPEAKER ASSEMBLY  
(Design differ depending on the specification)

No. 2 INSTRUMENT PANEL REGISTER ASSEMBLY

No. 1 INSTRUMENT PANEL REGISTER ASSEMBLY

No. 3 INSTRUMENT PANEL REGISTER ASSEMBLY

INTEGRATION CONTROL PANEL or MULTI-DISPLAY or DISPLAY AND NAVIGATION MODULE DISPLAY WITH RADIO RECEIVER ASSEMBLY

● Replacement part

N\*m (kgf\*cm, ft\*lb) : Specified torque

R1701240006

**3.9 N·m (40, 35 in.\*lbf)**  
**Be careful not to overtighten.**

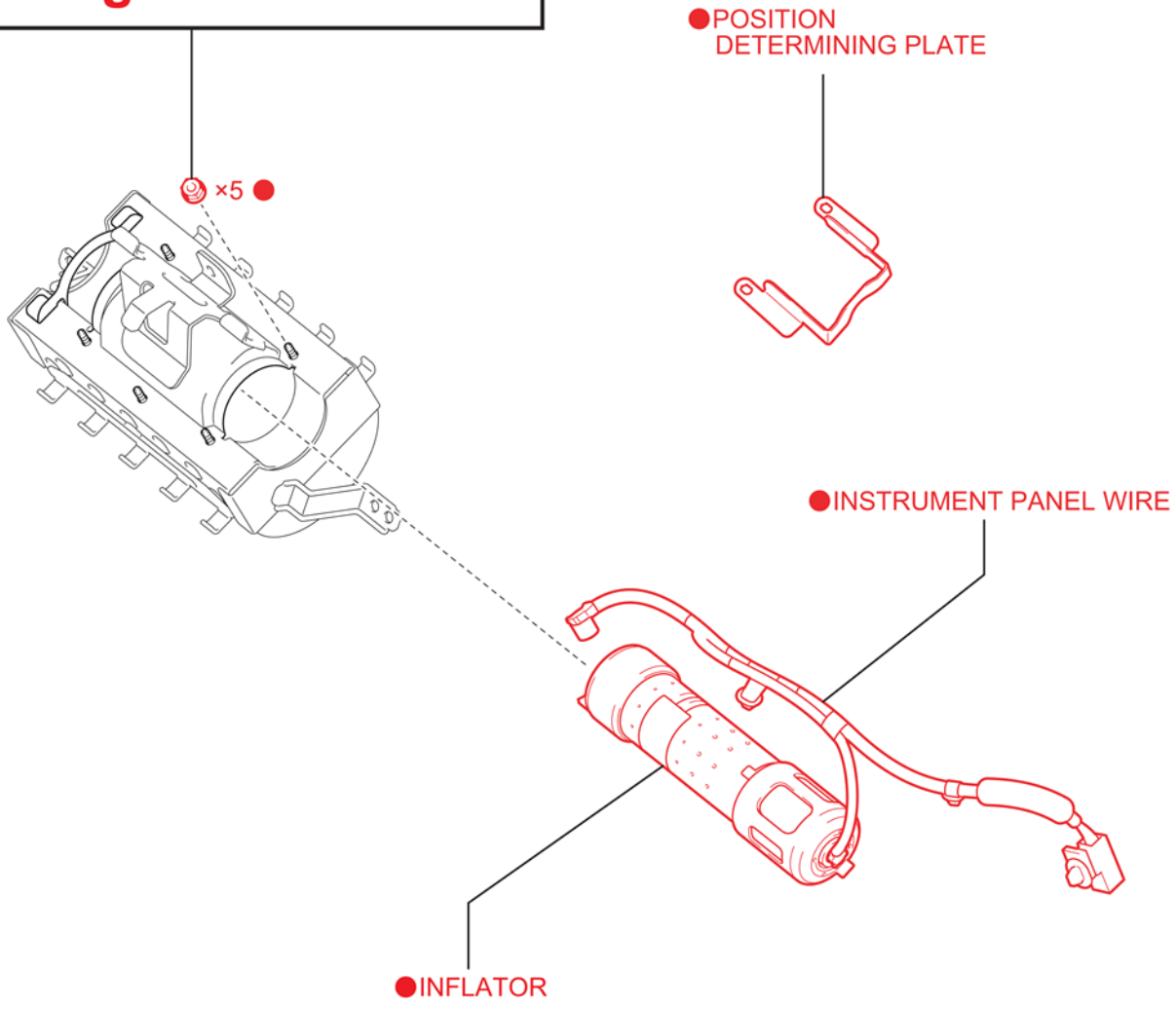

R1707250018A01

## 1. REMOVE THE AIRBAG MODULE



- Wait at least 90 seconds after disconnecting the cable from the negative battery terminal to prevent airbag and seat belt pre-tensioner deployment.
- Follow all precautions as outlined on TIS before servicing the SRS system.

a) Refer to TIS for removal instructions.

<a href="#">2007 MY</a>	<a href="#">2008 MY</a>	<a href="#">2009 MY</a>	<a href="#">2010 MY</a>	<a href="#">2011 MY</a>	<a href="#">2012 MY</a>
-------------------------	-------------------------	-------------------------	-------------------------	-------------------------	-------------------------

## 2. REMOVE THE INFLATOR FROM THE AIRBAG MODULE

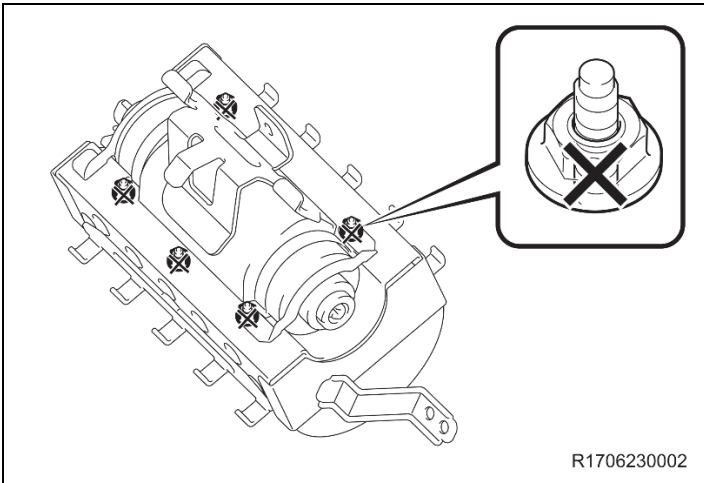

### 1. REMOVE THE INFLATOR

- a) Mark the 5 self locking nuts to prevent reuse.



b) Mount the adaptors (579943-3R3) to the airbag as shown.

**NOTE: The 6mm stud mounts to the airbag.**



c) Mount the airbag to the mounting bracket as shown.

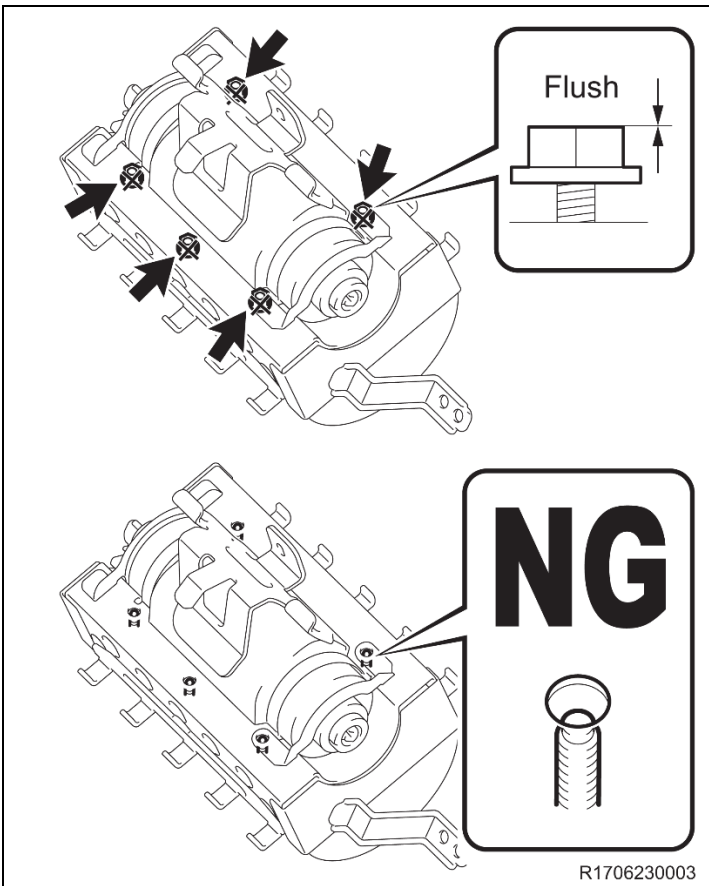

d) Loosen the 5 nuts until each nut is flush with the top of the stud as shown.

**NOTE: You may need to slide the airbag to the left or right to access the middle nut. DO NOT use power tools to remove the nuts.**

R1706230003

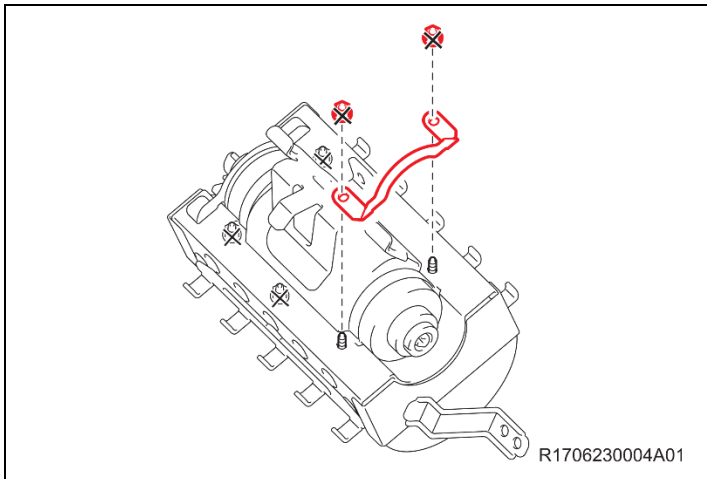

- e) Loosen and discard the 2 nuts on the end where the positioning plate is removeable.
- f) Remove and discard the plate.

**NOTE:**  
**DO NOT use power tools.**

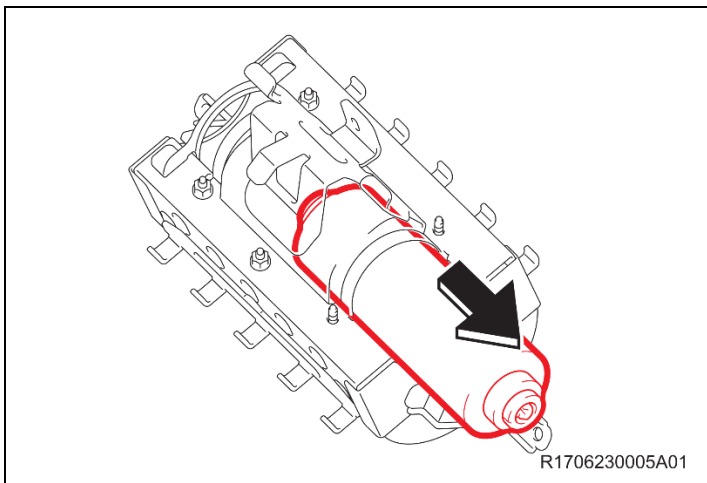

- g) Remove the inflator.

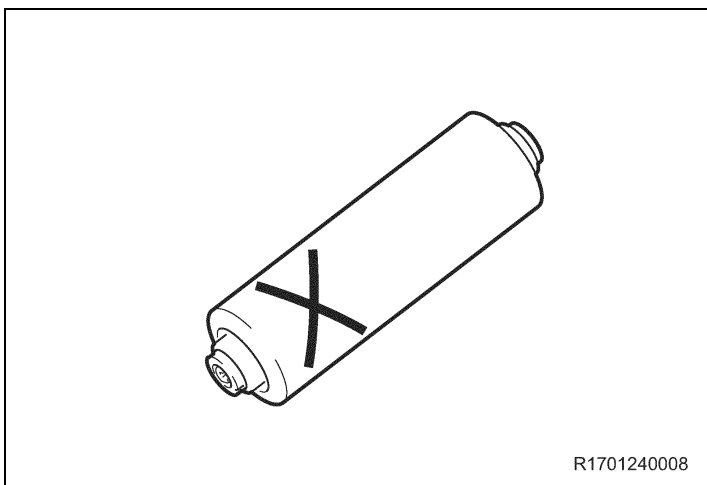

- h) Mark the old inflator so it is not reused.
- NOTE: Return the old inflator to the parts department for recovery.**

## VIII. AIRBAG RECORDING

### 1. LAUNCH THE SERIAL NUMBER RECORDING APPLICATION

Note: The Serial Number Recording Application is the same application used for a prior campaign.



- The serial numbers **MUST** be recorded using a barcode scanner (provided at the launch of SSC DLC).
- The barcode scanner application **MUST** be completed on every vehicle. These numbers **MUST** be included on every warranty claim that is submitted for airbag module replacement or the claim may be subject to debit.
- The technician performing the work **MUST** have valid TIS login credentials and an internet connection to perform the inspection and scanning process.

- a) Log in to TIS and input the VIN of the vehicle in the Vehicle Inquiry tab.
- b) Confirm the VIN is applicable and that the campaign has not been completed.
- c) Click on the link to be sent to the scanning application site.
- d) You can also log into the scanning site via the URL below

Log into the website via the URL below

<https://takata-scan-app.imagespm.info/>

User ID: Dealer Code

First time login password: xxxxx

The screenshot displays the Toyota TIS Vehicle Inquiry interface. At the top, navigation tabs include Home, TIS, TAS, PRS, and QAT. The 'Vehicle Inquiry' tab is active, showing a 'Vehicle Identification Number Search' section with a text input field containing the VIN '1NX-BR32E-000000000' and 'Clear' and 'Lookup' buttons. A red circle highlights the VIN input field, labeled 'a)'. Below this is the 'Vehicle Information' section, which lists details such as Division (TOYOTA), Model (Corolla), Grade (CE), Model Year (2003), Drive Type (2WD), Body Type (4Dr. Sedan), Engine Family (4-cylinder - 1ZZ), Transmission, Date of First Use, Production Date (01/18/2002), Plant Code (Z - FREMONT PLANT - NUMM), VIN (1NX-BR32E-000000000), Standard Equipment (Click here to display), Exterior Color (03M5, SANDRIFT METALLIC), Interior Color (FA41, FA41), Interior Trim Color (FA, \*), and Interior Fabric (F, \*). Below the vehicle information are tabs for Campaign, Service History, Warranty, DTC History, and Diagnostic Report. The 'Campaign' tab is selected, showing a 'Service Campaign' section with a 'Campaign Description' and a 'Completion Status' of 'Not Completed'. A red circle highlights the 'Completion Status' text, labeled 'b)'. Another red circle highlights a link that says 'check applicability for VIN', labeled 'c)'. The footer of the page includes '© 2013 Toyota Motor Sales, Inc.' and 'Feedback | Privacy | Legal'.

# Login

Complete all required (\*) fields below.

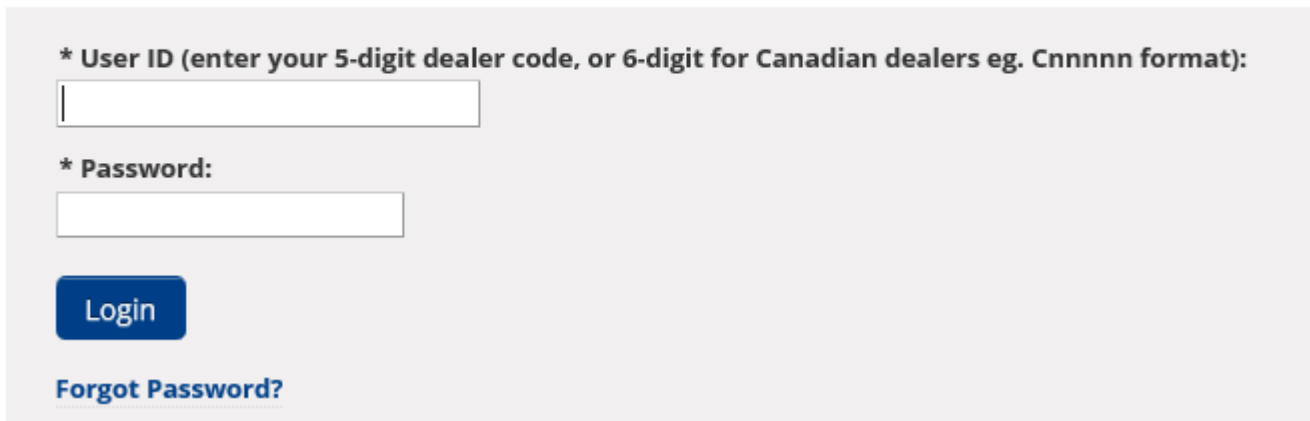

\* User ID (enter your 5-digit dealer code, or 6-digit for Canadian dealers eg. Cnnnnn format):

\* Password:

**Login**

[Forgot Password?](#)

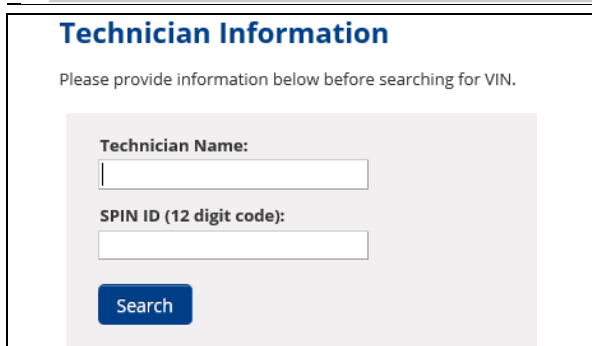

### Technician Information

Please provide information below before searching for VIN.

Technician Name:

SPIN ID (12 digit code):

**Search**

a) Enter your name and SPIN ID into the site

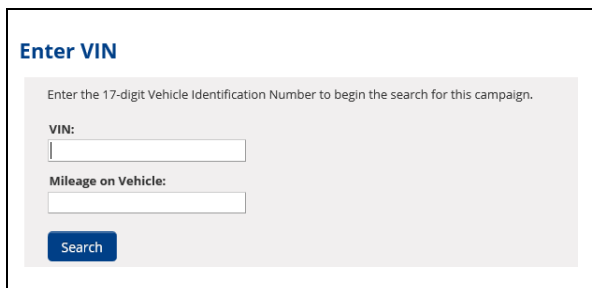

### Enter VIN

Enter the 17-digit Vehicle Identification Number to begin the search for this campaign.

VIN:

Mileage on Vehicle:

**Search**

b) Enter the VIN and vehicle mileage into the site

## 2. CONNECT THE BARCODE SCANNER

- Connect the barcode scanner to the USB port on the Techstream.
- The scanner will automatically connect and a beep will be heard when the scanner is ready.

### NOTE:

- The scanner was provided for SSC DLC.
- The barcode scanner works best in low light conditions.
- Always hold the scanner directly in front of and parallel to the barcode label.

### 3. SCAN THE AIRBAG SERIAL NUMBER

## ATTENTION: This information is **CRITICAL**

- a) Scan the **AIRBAG ASSEMBLY** serial number 2 times.
  - 1) Confirm the cursor is in the first serial number box then scan the serial.
  - 2) Position the cursor in the second serial number box then scan the serial.
- b) Click next.

#### NOTE:

- If both serial numbers that are entered do not match, confirm and reenter.
- If the serial number barcode will not scan, it can be entered manually.

#### AIRBAG SERIAL NUMBER IDENTIFICATION

- The airbag serial number is **ALWAYS** the **12 DIGITS** located between the asterisks.
- The 3 digits before the asterisk **ARE NOT** part of the serial number, and **SHOULD NOT** be entered or an inaccurate response may be returned.

#### Airbag Serial Number Label Example



The **AIRBAG ASSEMBLY** serial number and the **INFLATOR** serial number are **DIFFERENT**. The **AIRBAG ASSEMBLY** serial number **MUST** be recorded prior to replacement.

### ORIGINAL Airbag Assembly Serial Number

Scan or enter the **original** Airbag Assembly serial number into the website.

VIN:  
Model / Campaign:

\* Serial Number of *Original* Airbag Assembly:

\* Re-confirm the Serial Number of *Original* Airbag Assembly:

Check if the airbag serial number is missing or not visible, or if installing a new airbag assembly

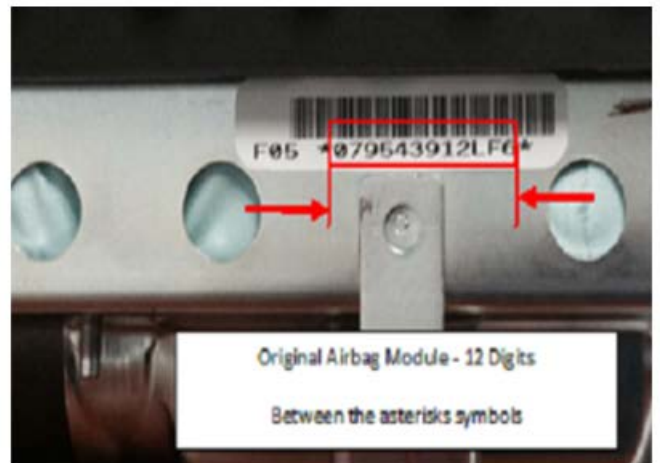

## AIRBAG SERIAL NUMBER IS MISSING OR IS UNREADABLE

**\*NOTE: Skip this section and jump to Section IX if the airbag assembly is scannable\***



If the airbag serial number and barcode are not legible or are not present, check the box in the application indicating the serial number is not legible and contact your regional representative.

- a) If the airbag serial number cannot be scanned or is not present check the box as shown below.

### ORIGINAL Airbag Assembly Serial Number

Scan or enter the **original** Airbag Assembly serial number into the website.

VIN:  
Model / Campaign:  
\* Serial Number of *Original* Airbag Assembly:  
\* Re-confirm the Serial Number of *Original* Airbag Assembly:  
 Check if the airbag serial number is missing or not visible, or if installing a new airbag assembly  
Search

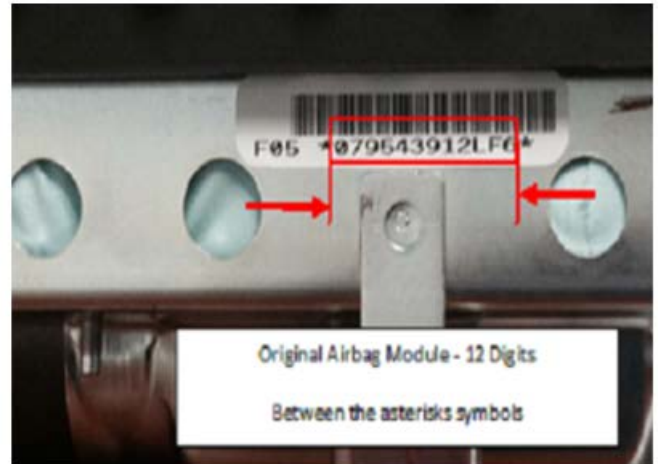

**Checking this box requires Air Bag Assembly replacement.**

**\*\*Note\*\* Contact your region in the event that you are unable to read the serial number.  
DO NOT ATTEMPT TO INSTALL INFLATOR**

- b) After the Region approves the Airbag Assembly replacement and the new part is received, scan the NEW airbag barcode in the Serial Number Recording Application.

## NEW Serial Number

Scan or enter the **new** Airbag Assembly Serial Number into the website.

VIN:

\* Serial Number of New Airbag Assembly:

\* Re-confirm the Serial Number of New Airbag Assembly:

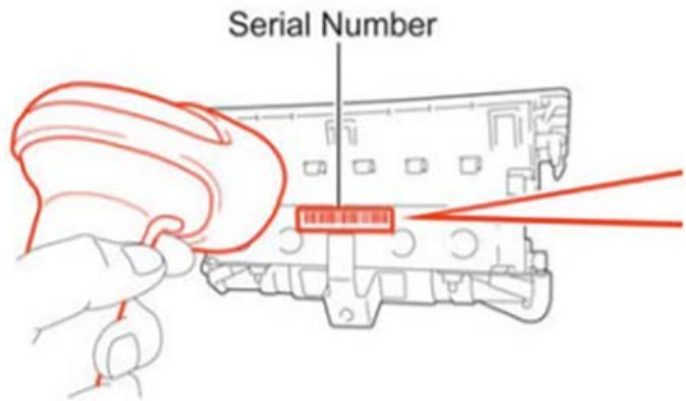

The new **AIRBAG ASSEMBLY** serial number **MUST** be recorded prior to reinstallation to track the airbag assembly to the vehicle.

**Skip to Section X** If a new airbag assembly was installed instead of an inflator



**ENSURE YOU ENTER BOTH THE OLD AND NEW INFLATOR SERIAL NUMBER IN THE APPROPRIATE SPOT OF THE APPLICATION  
-DO NOT ENTER THE AIRBAG SERIAL NUMBER FOR THIS STEP-**



**4. SCAN THE OLD AND NEW INFLATOR SERIAL NUMBER**

- a) Scan the **OLD** inflator serial number and mark the old inflator so that it will not be reused.
- b) Scan the **NEW** inflator QR code.

**ATTENTION: This information is CRITICAL**

- It is used to confirm the correct inflator is removed from the vehicle.
- It is recorded by TMS to trace the return parts shipment.
- It is used to track the new inflator that is being installed in the vehicle.

**ORIGINAL Inflator Serial Number**

Scan or enter the **original** Inflator serial number into the website.

VIN: 2T1BR32E57C810829  
 Model / Campaign: 2007 Corolla / E04

\* Serial Number of **Original** Inflator:

\* Re-confirm the Serial Number of **Original** Inflator:

Check if the inflator serial number is missing or not visible, OR if installing a new airbag assembly

**Search**



**REPLACEMENT Inflator Serial Number**

Scan or enter the **replacement** Inflator serial number into the website.

VIN: 2T1BR32E57C810829  
 Model / Campaign: 2007 Corolla / E04

\* Serial Number of **Replacement** Inflator:

\* Re-confirm the Serial Number of **Replacement** Inflator:

**Search**



c) If the inflator serial number cannot be scanned or is not present check the box as shown below.

## ORIGINAL Inflator Serial Number

Scan or enter the **original** Inflator serial number into the website.

VIN: 2T1BR32E57C810829  
Model / Campaign: 2007 Corolla / E04

\* Serial Number of *Original* Inflator:

\* Re-confirm the Serial Number of *Original* Inflator:

Check if the inflator serial number is missing or not visible. OR if installing a new airbag assembly



**Checking this box requires Air Bag Assembly replacement.**

**\*\*Note\*\* Contact your region in the event that you are unable to read the serial number.**

**DO NOT ATTEMPT TO INSTALL INFLATOR**

d) Confirm agreement by checking the two boxes.

e) Record the Warranty Authorization # to be included in the warranty claim.

f) Place the old inflator in the parts box and take it immediately to the parts department.

### NOTE:

- Confirm the cursor is in the correct serial number input box before scanning.
- If the serial number barcode will not scan, it can be entered manually.
- If there are any difficulties or concerns with this process, email [quality\\_compliance@toyota.com](mailto:quality_compliance@toyota.com) with details.

### Step e)

#### Takata Scan App (TEST v2) Final Results

You can [Print Screen](#) or [Search Another VIN](#).

<b>Results:</b>	<b>Inflator Replacement Required</b>
<b>Warranty Authorization Number:</b>	<b>77515K46</b> <small>This number is required for the warranty claim. Print and save this screen for your records</small>
VIN:	2T1BR32E57C810829
Vehicle:	2007 Corolla
Campaign:	E04
Original Airbag Serial:	123456789K12
Replacement Airbag Serial:	
Original Inflator Serial:	W0123456789
Replacement Inflator Serial:	W0123456789
Scan Date:	12/22/2020 08:47AM (mm/dd/yyyy)

## IX. VEHICLE REASSEMBLY

a) Install the inflator as shown below and ensure the inflator is oriented in the correct position as shown below.



**STOP**

- Make sure to follow the installation procedure carefully as the instrument panel wire connector cannot be disconnected once connected
- Make sure the inflator is correctly positioned.
- The inflator cannot be fully inserted if it is upside down.

Check orientation

Upper side

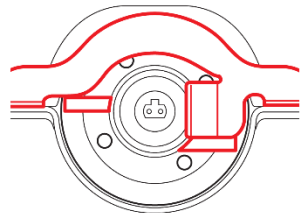

Bottom

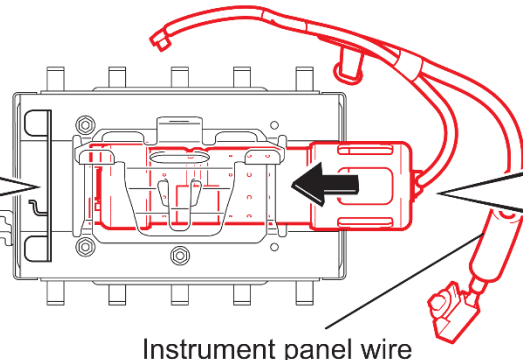

Instrument panel wire

Check orientation

Upper side

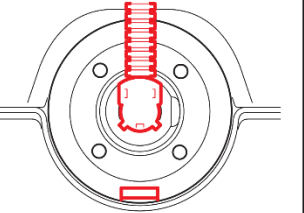

Bottom

R1707250019A02

**NG** DO NOT connect yet.

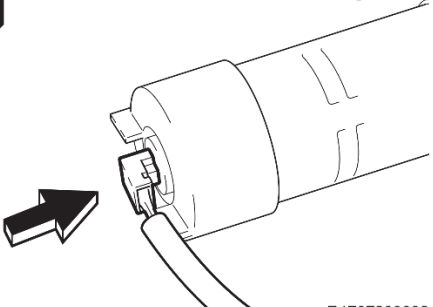

R1707280032



**STOP**

**DO NOT** connect the airbag connector yet.

**Install temporarily by hand.**

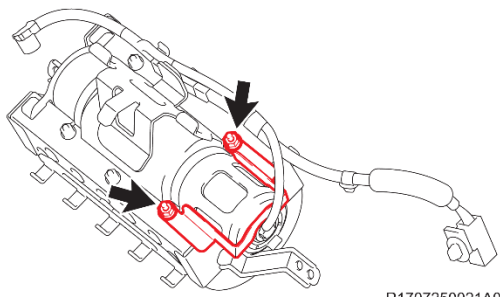

R1707250021A01

- a) Install the **NEW** positioner plate.
- b) Temporarily install 2 **NEW** nuts.

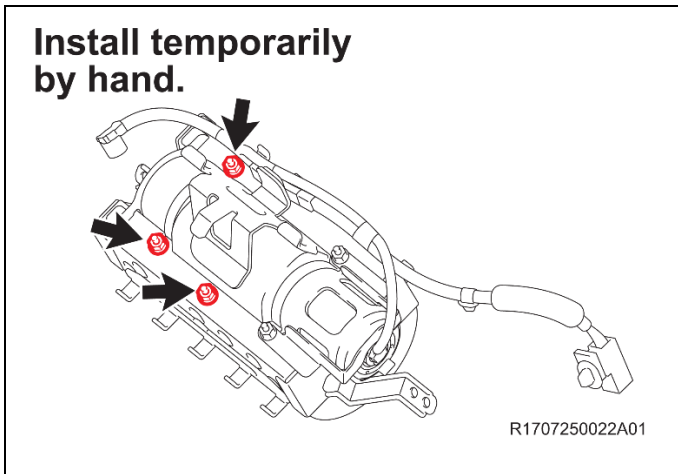

- c) Remove and discard the 3 remaining nuts.
- d) Temporarily install 3 **NEW** nuts.

e) Push the inflator towards the position determining plate and eliminate any gaps.

**STOP** • If any gaps exist, the flats may move apart and could result in abnormal operation during airbag deployment.

**(a) Replacement of parts.**

**(b) No gap.**

**Check orientation**  
Upper side  
Bottom

**Check orientation**  
Upper side  
Bottom

R1701260003Z01

f) Tighten the 5 nuts evenly in several increments in the sequence shown. Use a socket driver or torque wrench to tighten the nuts.

Torque: 35 in. lbf (3.9N·m)



- There will be some resistance when tightening the nuts because they are self-locking, confirm the nuts are tightened correctly.
- **DO NOT** use a power tool, T-handle, or ratchet when tightening the nuts to avoid over torquing and deforming the studs.
- You may need to slide the airbag to the left or right with in the mounting bracket to access the center nut.

# OK

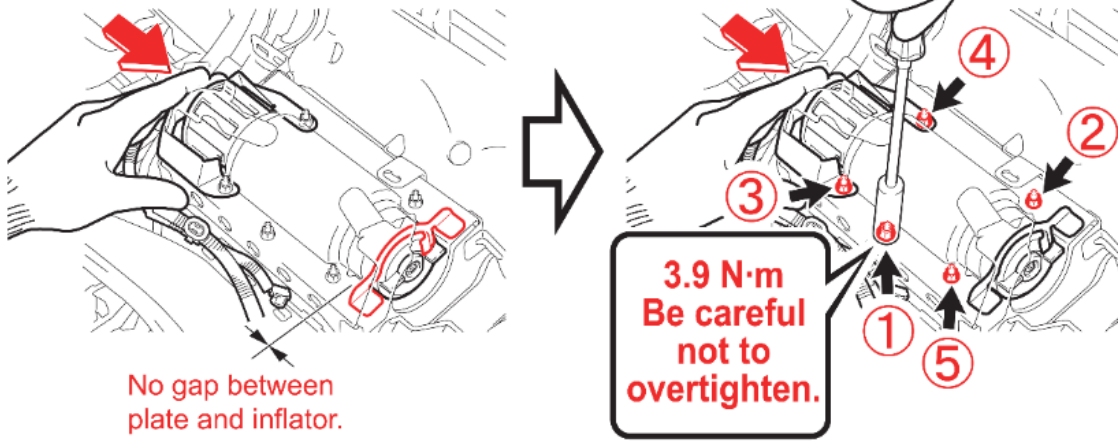

# NG

# NG

# NG



## These tools cause overtightening !

R1701260011Z01

- l) Connect the airbag connector to the instrument panel passenger airbag assembly and then push in the airbag connector lock as shown in the illustration.
- m) Engage the clamp.



- Make sure to correctly align the connectors before connecting them.
- Make sure that the airbag connector is securely connected.

### ALIGN CONNECTORS

Wire Harness Side:

Inflator Side:

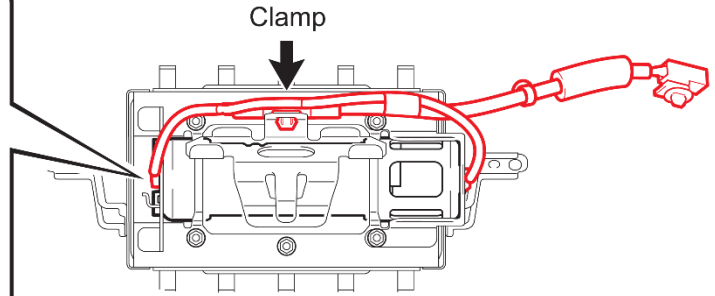
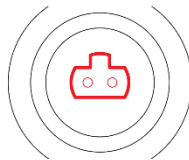
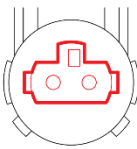

R1707280031

## X. VEHICLE REASSEMBLY

### 1. INSTALL THE NEW AIRBAG ASSEMBLY INTO THE INSTRUMENT PANEL

### 2. REINSTALL THE DASH

a) Refer to TIS for reinstallation instructions

<a href="#">2007 MY</a>	<a href="#">2008 MY</a>	<a href="#">2009 MY</a>	<a href="#">2010 MY</a>	<a href="#">2011 MY</a>	<a href="#">2012 MY</a>
-------------------------	-------------------------	-------------------------	-------------------------	-------------------------	-------------------------

### 3. RECONNECT THE NEGATIVE BATTERY CABLE

### 4. PERFORM A HEALTH CHECK AND DIAGNOSTIC REPORT

### 5. PERFORM ANY NEEDED SYSTEM INITIALIZATIONS

## ◀ VERIFY REPAIR QUALITY ▶

- Confirm all precautions are followed to ensure safety during the repair
  - Confirm the entire serial number checker application is completed and the warranty authorization # is recorded on *EVERY* vehicle
  - Confirm the old airbag is handled safely and given to the appropriate parts professional for shipment
- If you have any questions regarding this update, please contact your area representative.

## XI. APPENDIX

### A. CAMPAIGN DESIGNATION DECODER

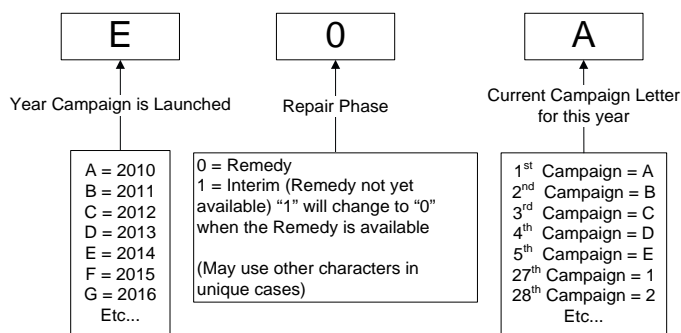

Examples:

A0D = Launched in 2010, Remedy Phase, 4<sup>th</sup> Campaign Launched in 2010

B1E = Launched in 2011, Interim Phase, 5<sup>th</sup> Campaign Launched in 2011

C1C = Launched in 2012, Interim Phase, 3<sup>rd</sup> Campaign Launched in 2012

### B. CAMPAIGN PARTS DISPOSAL

**ALL** airbags that are removed from vehicles under this campaign **MUST** be packaged and shipped back to the manufacturer following the manufacturer's instructions. The instructions can be found in the following locations:

- Attached to the dealer letter
- Included in the parts box