



AUTOMOBILE DIVISION
 American Honda Motor Co., Inc.
 1919 Torrance Blvd., – P.O. Box 2215
 Torrance, CA 90509-9870

REMEDY NOTICE

This is an important Safety Recall.
 The remedy will be performed
FOR FREE.

November 2018

NHTSA Recall 18V-661

IMPORTANT SAFETY RECALL

This notice applies to your vehicle: XXXXXXXXXXXXXXXXXXXX

Dear <First Name Last Name>,

This notice is sent to you in accordance with the National Traffic and Motor Vehicle Safety Act.

WHAT IS THE REASON FOR THIS NOTICE?

Honda has decided that a defect which relates to motor vehicle safety exists in certain XXXX model year XXX vehicles. The passenger frontal airbag inflator in your vehicle may explode when deploying during a crash. The potential for such explosion may occur in some of the subject airbag inflators after prolonged exposure to persistent conditions of high absolute humidity. In the event of a passenger frontal airbag inflator explosion, metal fragments could pass through the airbag cushion material, potentially resulting in serious injury or death to vehicle occupants. The risk of such an occurrence increases over time. It is imperative you schedule an appointment with an authorized Honda dealer now to avoid this condition in the future.

WHAT WILL HONDA DO?

Honda will replace the passenger frontal airbag inflator for free. An illustration showing the location of the passenger frontal airbag inflator, which is the only component of the airbag module (other components are the airbag cushion and airbag module cover) that will be replaced, during the recall repair, is shown on the right:

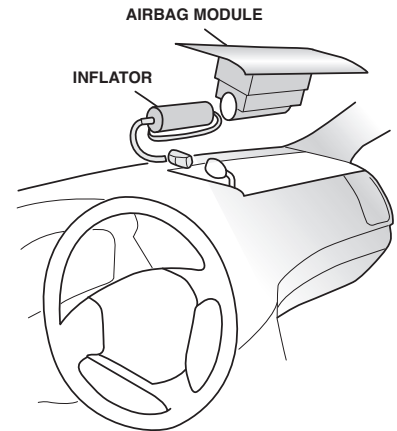

WHAT SHOULD YOU DO?

Please call any authorized Honda dealer and make an appointment to have your vehicle repaired for free. Once you make an appointment to repair your vehicle, be advised that the complete replacement process may take approximately 45 minutes. However, your dealer can provide you with a better estimate of the overall time for this service visit, as it may be necessary to make your vehicle available for a longer period of time. If you are not the only driver of this vehicle, please advise all other drivers and passengers of this important information!

Honda suggests that you avoid having a passenger sit in the front passenger's seat until the recall repair has been performed.

CHECK YOUR VEHICLE FOR OPEN RECALLS

You can check your vehicle's eligibility for repair under this or any other recall. Please visit the **Honda Recall Lookup** tool at www.recalls.honda.com and enter your Vehicle Identification Number (VIN).

OWNER INFORMATION

You received this notice because government regulations require that notification be sent to the last known owner of record. Our records are based primarily on state registration and title data, which indicate that you are the current owner of this vehicle. If this is not the case, or if any of the information is not correct, please complete, sign and return the Information Change Card and we will then update our records. If you are a lessor of this vehicle, federal regulations require you to forward this notice to your lessee within ten days.

DO YOU STILL HAVE MORE QUESTIONS?

If you have questions or concerns, we encourage you to visit hondaairbaginfo.com or to call American Honda's Customer Support & Campaign Center at 1-888-234-2138, Twitter @HondaCustSvc, email, or chat by going to <http://owners.honda.com/help/customer-relations>. You may also visit www.recalls.honda.com to use "Ask Dave", our 24/7 virtual agent.

If you believe that American Honda or the dealer has failed or is unable to remedy the defect in your vehicle, without charge, within a reasonable period of time (60 days from the date you first contact the dealer for a repair appointment), you may submit a complaint to the Administrator, National Highway Traffic Safety Administration, 1200 New Jersey Ave., SE, Washington, DC 20590. Alternatively, you may call the NHTSA's toll-free Safety Hotline at 888-327-4236 (TTY 800-424-9153), or go to <http://www.safercar.gov>.

We apologize for any inconvenience this recall may cause you.

Sincerely,

American Honda Motor Co., Inc.
Honda Automobile Division

Campaign #M2J / Service Bulletin #18-098