



---

## IMPORTANT SAFETY RECALL RECALL NO. 18E110

### January 2019

Customer  
XXXX CENTRAL AVE  
ALBANY, NY XXXXX

Dear Reese Elite Gooseball Customer:

This notice is sent to you in accordance with the requirements of the National Traffic and Motor Vehicle Safety Act.

Horizon Global Americas Inc. (Horizon) has decided that a defect which relates to motor vehicle safety exists in certain Reese Elite Gooseballs intended for aftermarket installation on GMC-Chevrolet pick-up trucks equipped with the factory OEM underbed package. We are notifying you because distribution records indicate that you have purchased one of these products.

Horizon has identified a compatibility issue with these parts when installed in these vehicles and is conducting a safety recall.

#### **What Products are Involved?**

This recall involves the Reese Elite Gooseball Hi-Rise Ball (Part No. 19315) and Reese Elite Gooseball GM kit (Part No. 30891), if these parts are installed on any GMC or Chevrolet pick-up truck MY 2016 - 2019 with GM factory underbed installed.

The compatibility issue does not affect installation of these parts in GMC and Chevrolet pick-up trucks equipped with Horizon's Elite underbed kit (Part No. 30868).

#### **What is the Problem?**

A design compatibility issue could lead to failure of the pin and potential disengagement of the retaining ball from the hitch's receiver. If the retaining ball disengages, the handle can separate from the gooseball. If the trailer is not using safety chains, the trailer could separate from the vehicle, increasing the risk of a crash.

## What Should You Do?

***Do not use the recalled product in your GMC or Chevrolet truck with a factory underbed package to tow your trailer.***

If you installed a gooseball 19315 stand alone (or as part of kit 30891) on your vehicle Model Year 2016, 2017, 2018 or 2019 GMC or Chevrolet pick-up truck with the factory-installed underbed, you should return the gooseball to the place of purchase, or any authorized Horizon dealer, for a full refund. If you installed one of the products on your Ford, Ram, or Nissan pick-up truck, or if your GMC or Chevrolet pick-up uses Horizon's Elite underbed (Part No. 30868), you are not affected by this issue.

Note: The part number is not on the gooseball. Please refer to the following photograph and drawing to identify the affected product:

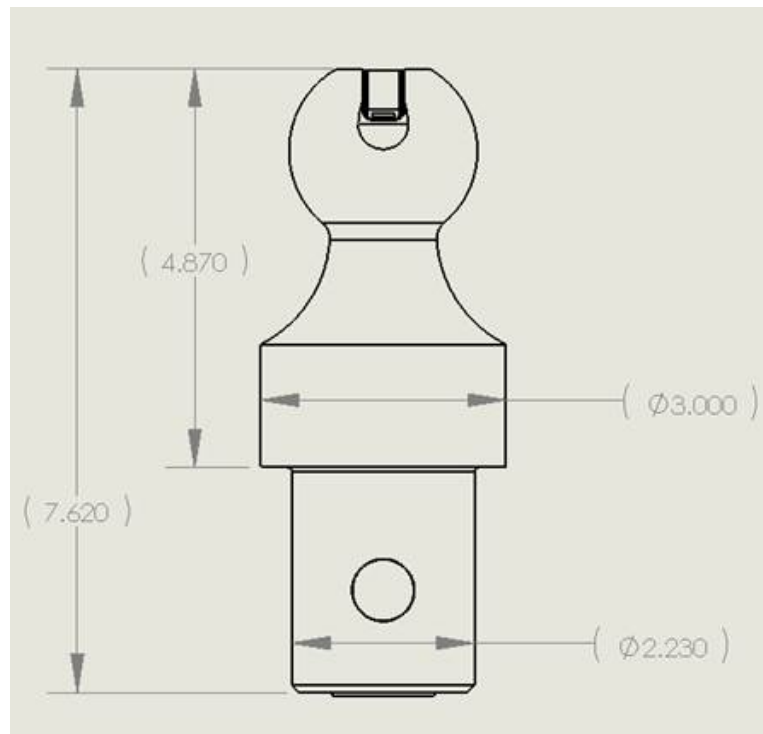

## Questions or Concerns?

If you have questions or concerns about this recall, please contact Horizon at 1-877-973-7871. If you are unable to obtain a remedy without charge within a reasonable time, you may submit a complaint to: Administrator, National Highway Traffic Safety Administration, 1200 New Jersey Avenue, SE, Washington, DC 20590; or call the toll-free Vehicle Safety Hotline at 1-888-327-4236 (TTY: 1-800-424-9153); or go to <http://www.safercar.gov>.

Horizon is taking this action in the interest of your safety and satisfaction with our products. We apologize for any inconvenience and thank you for your attention to this matter.

Sincerely,

Campaign Administrator  
Horizon Global Americas Inc.