



David J. Johnson
Director
Service Engineering Operations
Ford Customer Service Division

Ford Motor Company
P. O. Box 1904
Dearborn, Michigan 48121

December 20, 2018

TO: All U.S. Ford and Lincoln Dealers

**SUBJECT: NEW VEHICLE DEMONSTRATION / DELIVERY HOLD -
Safety Recall 18S45**

Certain 2015 - 2019 Model Year F-150 and 2017 – 2019 Model Year F-Super Duty
Vehicles Equipped with Engine Block Heaters
Engine Block Heater Wire Assembly - Water Intrusion/Corrosion

AFFECTED VEHICLES

Vehicle	Model Year	Assembly Plant	Build Dates
F-150	2015-2019	Dearborn Truck	March 18, 2014 through November 17, 2018
F-150	2015-2019	Kansas City	August 21, 2014 through November 17, 2018
F-Super Duty 6.7L Diesel Engine	2017-2018	Kentucky Truck	October 8, 2015 through October 24, 2017
F-Super Duty 6.2L & 6.8L Gas Engine	2017-2019	Kentucky Truck	October 9, 2015 through November 17, 2018
F-Super Duty	2017-2019	Ohio	February 5, 2016 through November 17, 2018

Known affected vehicles are identified in OASIS and FSA VIN Lists.

This recall may also affect vehicles fitted with over-the-counter genuine Ford engine block heater kits, with a Ford part number on the label.

REASON FOR THIS SAFETY RECALL

In some of the affected vehicles, the engine block heater wire assembly may be susceptible to excess water intrusion or corrosion in the in-line connector. While the vehicle is parked and the block heater is plugged in, an inoperative engine block heater, tripping of household breakers or GFCI equipped outlets, and/or resistive short may result. A resistive short may increase the risk of overheated or melted wiring, and/or fire.

SERVICE ACTION

Before demonstrating or delivering any new in-stock vehicles involved in this recall, dealers are to inspect the engine block-heater wire assembly in-line connector for water intrusion and/or corrosion:

- Pass, apply electric grease, no part replacement required.
- Failed, part is available, replace engine block heater wire assembly, and apply electric grease to in-line connector on new wire assembly before installing on vehicle.

- Failed, no parts available, dry in-line connector, apply grease, use labor operation 18S45BB as an interim repair, and provide a copy of Attachment VI Customer Information Sheet to customer.

This service must be performed on all affected vehicles at no charge to the vehicle owner.

At this time, parts are not available to repair all vehicles; however, less than 6% of the affected vehicle population is expected to require engine block heater wire assembly replacement. Until parts are available to repair all vehicles, dealers may submit an approval request, with photos of corrosion in the in-line connector, to the SSSC to authorize repairs on customer-owned vehicles in extenuating circumstances and unsold vehicles with a signed sales contact. Parts to repair all vehicles are expected to be available first quarter 2019, at which time this bulletin will be supplemented.

Over-The-Counter Engine Block Heater Kit Sales

Dealers are to review their part sales records and contact any customers to whom an affected genuine Ford engine block heater kit has been sold. Give the customer a copy of the Owner Notification Letter and schedule a service date when parts are available.

Please contact the Special Service Support Center (SSSC) via the Web Contact Site, using a VIN specific Non-Involved Vehicle Request to request adding an affected VIN to this safety recall prior to performing this service action. Please include an image of the genuine Ford Part Number label with the engine block heater kit installed and a photo of the Vehicle Certification Label showing the VIN.

OWNER NOTIFICATION MAILING SCHEDULE

Owner letters are expected to be mailed the week of January 7, 2019. Dealers should repair any affected vehicles that arrive at their dealerships, whether or not the customer has received a letter.

PLEASE NOTE:

Federal law requires dealers to complete this recall service before a new vehicle is delivered to the buyer or lessee. Violation of this requirement by a dealer could result in a civil penalty of up to \$21,000 per vehicle. Correct all vehicles in your new vehicle inventory before delivery.

ATTACHMENTS

Attachment I: Administrative Information
 Attachment II: Labor Allowances and Parts Ordering Information
 Attachment III: Technical Information – All Vehicles - Inspection Procedure
 Attachment IV: Technical Information – F-150 Vehicles – Cord Replacement Procedure
 Attachment V: Technical Information - Super Duty Vehicles – Cord Replacement Procedure
 Attachment VI: Customer Information Sheet - Did Not Pass Inspection
 Owner Notification Letter
 Recall Reimbursement Plan

QUESTIONS & ASSISTANCE

For questions and assistance, contact the Special Service Support Center (SSSC) via the SSSC Web Contact Site. The SSSC Web Contact Site can be accessed through the Professional Technician Society (PTS) website using the SSSC link listed at the bottom of the OASIS VIN report screen or listed under the SSSC tab.

Sincerely,



David J. Johnson

**NEW VEHICLE DEMONSTRATION / DELIVERY HOLD -
Safety Recall 18S45**

Certain 2015 - 2019 Model Year F-150 and 2017 – 2019 Model Year F-Super Duty Vehicles
Equipped With Engine Block Heaters
Engine Block Heater Wire assembly Water Intrusion/Corrosion

OASIS ACTIVATION

OASIS will be activated on December 20, 2018.

FSA VIN LISTS ACTIVATION

FSA VIN Lists will be available through <https://web.fsavinlists.dealerconnection.com> on December 20, 2018. Owner names and addresses will be available by January 22, 2019.

- Because over-the-counter sales are not reported to Ford Motor Company, FSA VIN Lists may be incomplete for this safety recall.

NOTE: Your FSA VIN Lists may contain owner names and addresses obtained from motor vehicle registration records. The use of such motor vehicle registration data for any purpose other than in connection with this recall is a violation of law in several states, provinces, and countries. Accordingly, you must limit the use of this listing to the follow-up necessary to complete this recall.

SOLD VEHICLES

- Ford has not issued instructions to stop selling/delivering or driving used vehicles under this safety recall. Owners should contact their dealer for an appointment to have their vehicles remedied as soon as practical. Owners can continue to safely drive their vehicles if they follow all instructions and warnings contained in the recall notice.
- Immediately contact any customers who have purchased a Ford Engine Block Heater kit through your dealership. Give the customer a copy of the Owner Notification Letter (when available) and schedule a service date.
- Owners of affected vehicles will be directed to dealers for repairs.
- Immediately contact any of your affected customers whose vehicles are not on your VIN list but are identified in OASIS. Give the customer a copy of the Owner Notification Letter (when available) and schedule a service date.
- Correct other affected vehicles identified in OASIS which are brought to your dealership.
- Dealers are to prioritize repairs of customer vehicles over repairs of new and used vehicle inventory.

STOCK VEHICLES

- Correct all affected units in your new vehicle inventory before delivery.
- Use OASIS to identify any affected vehicles in your used vehicle inventory.

DEALER-OPERATED RENTAL VEHICLES

The Fixing America's Surface Transportation (FAST) Act law effective June 2016 prohibits a rental company from selling, renting or leasing vehicles subject to a safety or compliance recall. Please consult your legal counsel for legal advice.

TITLE BRANDED / SALVAGED VEHICLES

Affected title branded and salvaged vehicles are eligible for this recall.

**NEW VEHICLE DEMONSTRATION / DELIVERY HOLD -
Safety Recall 18S45**

Certain 2015 - 2019 Model Year F-150 and 2017 – 2019 Model Year F-Super Duty Vehicles
Equipped With Engine Block Heaters
Engine Block Heater Wire assembly Water Intrusion/Corrosion

OWNER REFUNDS

- **This safety recall must still be performed, even if the owner has paid for a previous repair. Claiming a refund will not close the recall on the vehicle.**
- Ford Motor Company is offering a refund for owner-paid repairs covered by this recall if the repair was performed prior to the date indicated in the reimbursement plan, which is posted with this bulletin. Owners are directed to seek reimbursement through authorized dealers or, at their option, directly through Ford Motor Company at P.O. Box 6251, Dearborn, MI 48121-6251.
- Dealers are also pre-approved to refund owner-paid emergency repairs that were performed away from an authorized servicing dealer after the end date specified in the reimbursement plan. Non-covered repairs, or those judged by Ford to be excessive, will not be reimbursed.
- Refunds will only be provided for the cost associated with the replacement of the genuine Ford engine block heater wire assembly with base part number 6B018.
 - Installation of complete engine block heater kits are not covered (example, base part number 6D008 or equivalent is not reimbursable).
 - Installation of a non-Ford aftermarket engine block heater kit is not reimbursable.

RENTAL VEHICLES

Rental vehicles are not approved for this program.

Ford has not issued instructions to stop driving used vehicles under this safety recall. Owners can continue to safely drive their vehicles until this safety recall has been completed.

Part shortages are not considered extenuating circumstances and do not qualify for rental vehicles with this program.

**NEW VEHICLE DEMONSTRATION / DELIVERY HOLD -
Safety Recall 18S45**

Certain 2015 - 2019 Model Year F-150 and 2017 – 2019 Model Year F-Super Duty Vehicles
Equipped With Engine Block Heaters
Engine Block Heater Wire assembly Water Intrusion/Corrosion

ADDITIONAL REPAIR (LABOR TIME AND/OR PARTS)

Additional repairs identified as necessary to complete the FSA should be managed as follows:

- For related damage and access time requirements, refer to the Warranty and Policy Manual / Section 6 – Ford & Lincoln Program Policies / General Information & Special Circumstances for FSA's / Related Damage.
- For vehicles within new vehicle bumper-to-bumper warranty coverage, no SSSC approval is required, although related damage must be on a separate repair line with the "Related Damage" radio button checked.
 - Ford vehicles – 3 years or 36,000 miles
- For vehicles outside new vehicle bumper-to-bumper warranty coverage, submit an Approval Request to the SSSC Web Contact Site prior to completing the repair.

CLAIMS PREPARATION AND SUBMISSION

- **Claim Entry:** Enter claims using Dealer Management System (DMS) or One Warranty Solution (OWS) online.
 - When entering claims, select claim type 31: Field Service Action. The FSA number 18S45 is the sub code.
 - For additional claims preparation and submission information, refer to the Recall and Customer Satisfaction Program (CSP) Repairs in the OWS User Guide.
- **Related Damage/Additional labor and/or parts:** Must be claimed as Related Damage on a separate repair line from the FSA with same claim type and sub code as described in Claim Entry above.

IMPORTANT: Click the Related Damage Indicator radio button.
- Provision for Misc. Expense: Motorcraft Electrical Grease XG-12
 - Program Code: 18S45
 - Misc. Expense: OTHER
 - Amount: Actual cost up to \$2.00
 - Estimated five vehicles per tube, four tubes per box.
- **Refunds:** Submit refunds on a separate repair line.
 - Program Code: 18S45 - Misc. Expense: ADMIN
 - Misc. Expense: REFUND - Misc. Expense: 0.2 Hrs.
 - Multiple refunds should be submitted on one repair line and the invoice details for each repair should be detailed in the comments section of the claim.

**NEW VEHICLE DEMONSTRATION / DELIVERY HOLD -
Safety Recall 18S45**

Certain 2015 - 2019 Model Year F-150 and 2017 – 2019 Model Year F-Super Duty Vehicles
Equipped With Engine Block Heaters
Engine Block Heater Wire assembly Water Intrusion/Corrosion

LABOR ALLOWANCES

Vehicle/Engine	Description	Labor Operation	Labor Time
All	Inspect, Pass, Apply Grease, No Parts Replaced	18S45A	0.3 Hours
All	Inspect, Fail, Clean, Apply Grease, No Parts Available, Interim Repair, Provide copy of Attachment VI Customer Information Sheet Claiming labor operation 18S45BB will not close the safety recall	18S45BB	0.3 Hours
F-150, 2.7L	Inspect, Fail, Part available, Replace, Apply Grease to New Connector	18S45C	1.1 Hours
F-150, 3.0L Diesel	Inspect, Fail, Part available, Replace, Apply Grease to New Connector	18S45D	0.9 Hours
F-150, 3.3L/3.5L TIVCT	Inspect, Fail, Part available, Replace, Apply Grease to New Connector	18S45E	0.4 Hours
F-150 3.5L GTDI 4X2 and 5.0L 4X4	Inspect, Fail, Part available, Replace, Apply Grease to New Connector	18S45F	0.7 Hours
F-150, 3.5L TIVCT, 4X4	Inspect, Fail, Part available, Replace, Apply Grease to New Connector	18S45G	1.0 Hours
F-150, 3.5L GTDI, Raptor	Inspect, Fail, Part available, Replace, Apply Grease to New Connector	18S45H	0.9 Hours
F-150, 5.0L 4X2	Inspect, Fail, Part available, Replace, Apply Grease to New Connector	18S45J	0.3 Hours
F-Super Duty, 6.2L	Inspect, Fail, Part available, Replace, Apply Grease to New Connector	18S45K	0.4 Hours
F-250/F-350, 6.7L	Inspect, Fail, Part available, Replace, Apply Grease to New Connector	18S45L	0.7 Hours
F-Super Duty, 6.8L	Inspect, Fail, Part available, Replace, Apply Grease to New Connector	18S45M	0.5 Hours
F-450/F-550, 6.7L	Inspect, Fail, Part available, Replace, Apply Grease to New Connector	18S45N	0.9 Hours

PARTS REQUIREMENTS / ORDERING INFORMATION

Parts are not yet available to repair all vehicles which require engine block heater wire assembly replacement due to corrosion. Additional information to support this safety recall will be published to dealers as a supplement in the first quarter 2019. Until parts are available to repair all vehicles, dealers may only repair customer-owned vehicles in extenuating circumstances and unsold vehicles with a signed sales contact.

**NEW VEHICLE DEMONSTRATION / DELIVERY HOLD -
Safety Recall 18S45**

Certain 2015 - 2019 Model Year F-150 and 2017 – 2019 Model Year F-Super Duty Vehicles
Equipped With Engine Block Heaters
Engine Block Heater Wire assembly Water Intrusion/Corrosion

To place an order for the engine block heater wire assembly, submit a VIN-specific Part Order contact via the SSSC Web Contact Site, along with photos of corrosion in the in-line connector. Obtain the VIN-specific part number from the Ford Parts Catalog to ensure the correct engine block heater wire assembly is obtained; as there are multiple model year and build date ranges.

Part Number	Vehicle	Description	Order Quantity	Claim Quantity
KC3Z-6B018-A	F-Super Duty 6.7L Diesel	Engine Heater Wire Assy.	1	1
HC3Z-6B018-D	F-Super Duty 6.8L Gas	Engine Heater Wire Assy.	1	1
HC3Z-6B018-E	F-Super Duty 6.2L Gas	Engine Heater Wire Assy.	1	1
JL3Z-6B018-A	F-150 3.3L	Engine Heater Wire Assy.	1	1
JL3Z-6B018-B	F-150 2.7L	Engine Heater Wire Assy.	1	1
JL3Z-6B018-C	F-150 3.5L	Engine Heater Wire Assy.	1	1
JL3Z-6B018-D	F-150 3.0L Diesel	Engine Heater Wire Assy.	1	1
JL3Z-6B018-E	F-150 5.0L	Engine Heater Wire Assy.	1	1
FL3Z-6B018-E	F-150 5.0L	Engine Heater Wire Assy.	1	1
HL3Z-6B018-A	F-150 3.5L GTDI	Engine Heater Wire Assy.	1	1
FL3Z-6B018-C	F-150 3.5L GTDI	Engine Heater Wire Assy.	1	1
FL3Z-6B018-A	F-150 3.5L Cyclone Petrol	Engine Heater Wire Assy.	1	1
HL3Z-6B018-B	F-150 3.5L Cyclone Petrol	Engine Heater Wire Assy.	1	1
FL3Z-6B018-D	F-150 2.7L	Engine Heater Wire Assy.	1	1

Dealers will be notified via a DOES II communication if circumstances warrant a change in part supply strategy and when open ordering resumes.

Order the parts below through normal order processing channels:

Part Number	Vehicle	Description	Order Quantity	Claim Quantity
XG-12	All	Electrical Grease (box of 4 tubes – 5 vehicles per tube)		Claim as MISC. OTHER

To guarantee the shortest delivery time, an emergency order for parts must be placed.

Less than 6% of the affected vehicle population is expected to require engine block heater wire assembly replacement. Ordering excess inventory results in large back-orders, and is not recommended.

NEW VEHICLE DEMONSTRATION / DELIVERY HOLD -

Safety Recall 18S45

Certain 2015 - 2019 Model Year F-150 and 2017 – 2019 Model Year F-Super Duty Vehicles

Equipped With Engine Block Heaters

Engine Block Heater Wire assembly Water Intrusion/Corrosion

DEALER PRICE

For latest prices, refer to DOES II.

PARTS RETENTION AND RETURN

Follow the provisions of the Warranty and Policy Manual, Section 1 - WARRANTY PARTS RETENTION AND RETURN POLICIES.

EXCESS STOCK RETURN

Excess stock returned for credit must have been purchased from Ford Customer Service Division in accordance with Policy Procedure Bulletin 4000.

CERTAIN 2015 - 2019 MODEL YEAR F-150 AND 2017 – 2019 MODEL YEAR F-SUPER DUTY VEHICLES EQUIPPED WITH ENGINE BLOCK HEATERS — ENGINE BLOCK HEATER WIRE ASSEMBLY WATER INTRUSION/CORROSION

OVERVIEW

In some of the affected vehicles, the engine block heater wire assembly may be susceptible to excess water intrusion or corrosion in the in-line connector. While the vehicle is parked and the block heater is plugged in, an inoperative engine block heater, tripping of household breakers or GFCI equipped outlets, and/or resistive short may result. A resistive short may increase the risk of overheated or melted wiring, and/or fire. Before demonstrating or delivering any new in-stock vehicles involved in this recall, dealers are to inspect the engine block-heater wire assembly in-line connector for water intrusion and/or corrosion:

SERVICE PROCEDURE

- Pass, apply electric grease, no part replacement required.
- Failed, part is available, replace engine block heater wire assembly, and apply electric grease to in-line connector on new wire assembly before installing on vehicle.
- Failed, no parts available, dry in-line connector, apply grease, use labor operation 18S45BB as an interim repair, and provide a copy of Attachment VI Customer Information Sheet to customer.

This service must be performed on all affected vehicles at no charge to the vehicle owner.

At this time, parts are not available to repair all vehicles; however, less than 6% of the affected vehicle population is expected to require engine block heater wire assembly replacement. Until parts are available to repair all vehicles, dealers may submit an approval request, with photos of corrosion in the in-line connector, to the SSSC to authorize repairs on customer-owned vehicles in extenuating circumstances and unsold vehicles with a signed sales contact. Parts to repair all vehicles are expected to be available first quarter 2019, at which time this bulletin will be supplemented.

Over – The – Counter Engine Block Heater Kit Sales

Dealers are to review their part sales records and contact any customers to whom an affected genuine Ford engine block heater kit has been sold. Give the customer a copy of the Owner Notification Letter and schedule a service date when parts are available.

Please contact the Special Service Support Center (SSSC) via the Web Contact Site, using a VIN specific Non-Involved Vehicle Request to request adding an affected VIN to this safety recall prior to performing this service action. Please include an image of the genuine Ford Part Number label with the engine block heater kit installed and a photo of the Vehicle Certification Label showing the VIN.

INSPECTION PROCEDURE

Recommended Tool List For Replacement:

General Tools	General Equipment
Blow Gun	Flash Light



1. Inspect the wire assembly at the in-line connector behind the front bumper for water intrusion or corrosion on both sides of the wire assembly. See Figure 1.

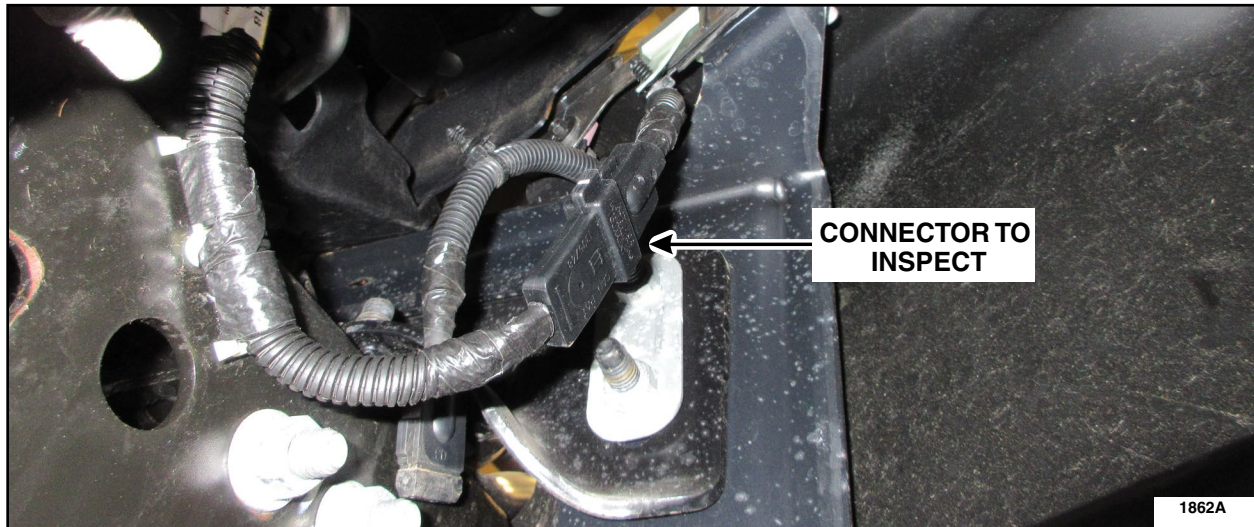

FIGURE 1

2. Does the wire assembly in-line connector appear corroded on one or both sides? See Figure 2 and 3.

Fail but parts are not available - Clean the in-line connector on both sides, blow out connector with compressed air and apply XG-12 Motorcraft® Electrical Grease or equivalent to both sides. Provide Attachment VI to the customer and claim labor box 18S45BB.

Fail and parts are available - Replace the wire assembly.

- See attachment IV for F-150 Vehicles.
- See attachment V for F-Super Duty Vehicles.

Pass - Apply XG-12 Motorcraft® Electrical Grease or equivalent to both sides of the wire assembly in-line connector and close the recall.

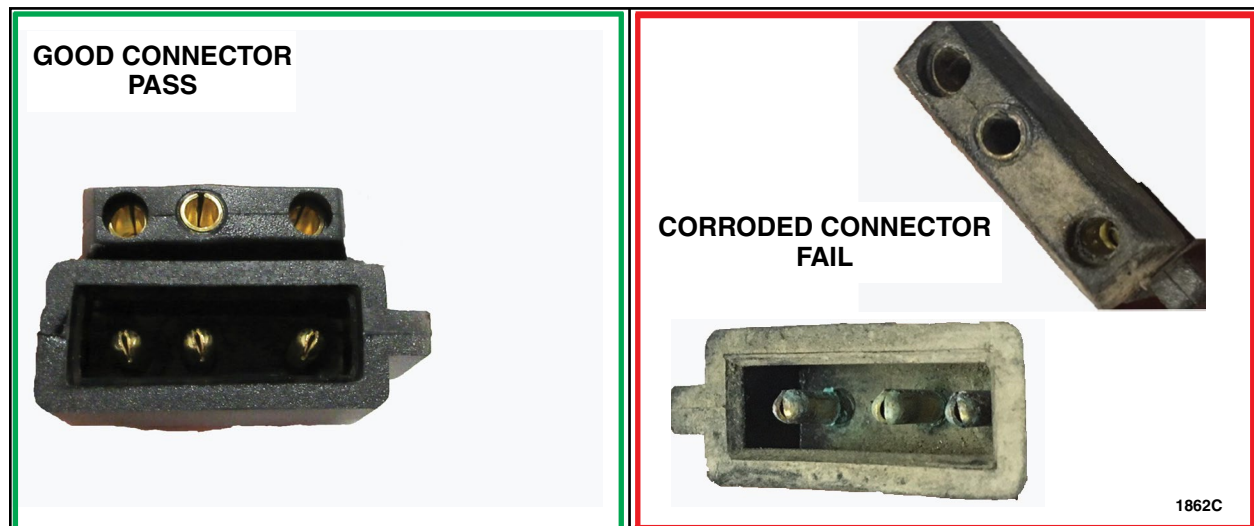

FIGURE 2



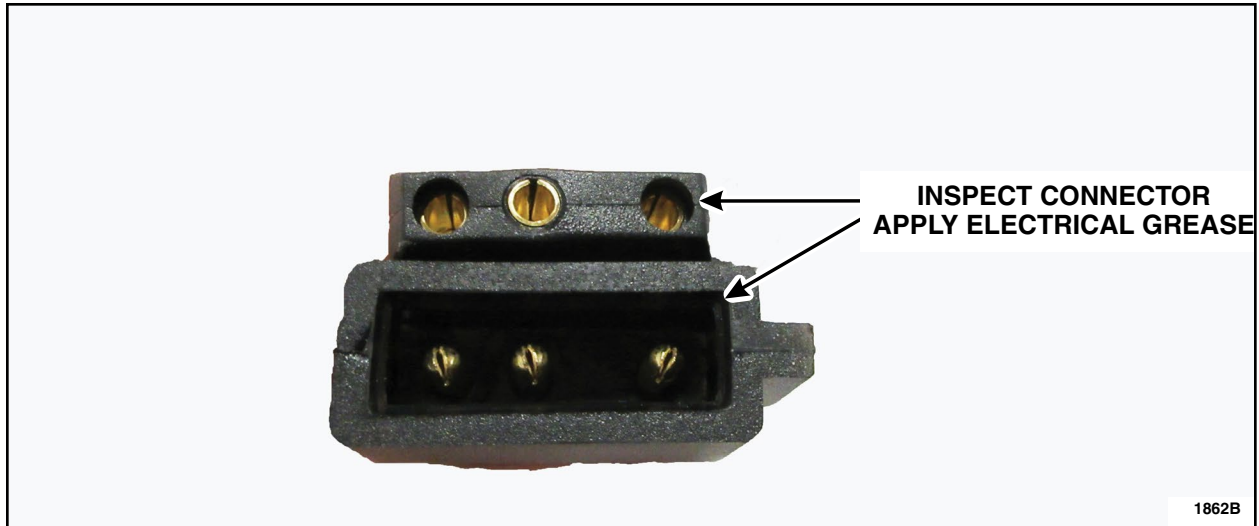

FIGURE 3



CERTAIN 2015 - 2019 MODEL YEAR F-150 AND 2017 – 2019 MODEL YEAR F-SUPER DUTY VEHICLES EQUIPPED WITH ENGINE BLOCK HEATERS — ENGINE BLOCK HEATER WIRE ASSEMBLY WATER INTRUSION/CORROSION

OVERVIEW

In some of the affected vehicles, the engine block heater wire assembly may be susceptible to excess water intrusion or corrosion in the in-line connector. While the vehicle is parked and the block heater is plugged in, an inoperative engine block heater, tripping of household breakers or GFCI equipped outlets, and/or resistive short may result. A resistive short may increase the risk of overheated or melted wiring, and/or fire. Before demonstrating or delivering any new in-stock vehicles involved in this recall, dealers are to inspect the engine block-heater wire assembly in-line connector for water intrusion and/or corrosion:

SERVICE PROCEDURE

- Pass, apply electric grease, no part replacement required.
- Failed, part is available, replace engine block heater wire assembly, and apply electric grease to in-line connector on new wire assembly before installing on vehicle.
- Failed, no parts available, dry in-line connector, apply grease, use labor operation 18S45BB as an interim repair, and provide a copy of Attachment VI Customer Information Sheet to customer.

This service must be performed on all affected vehicles at no charge to the vehicle owner.

At this time, parts are not available to repair all vehicles; however, less than 6% of the affected vehicle population is expected to require engine block heater wire assembly replacement. Until parts are available to repair all vehicles, dealers may submit an approval request, with photos of corrosion in the in-line connector, to the SSSC to authorize repairs on customer-owned vehicles in extenuating circumstances and unsold vehicles with a signed sales contact. Parts to repair all vehicles are expected to be available first quarter 2019, at which time this bulletin will be supplemented.

Over – The – Counter Engine Block Heater Kit Sales

Dealers are to review their part sales records and contact any customers to whom an affected genuine Ford engine block heater kit has been sold. Give the customer a copy of the Owner Notification Letter and schedule a service date when parts are available.

Please contact the Special Service Support Center (SSSC) via the Web Contact Site, using a VIN specific Non-Involved Vehicle Request to request adding an affected VIN to this safety recall prior to performing this service action. Please include an image of the genuine Ford Part Number label with the engine block heater kit installed and a photo of the Vehicle Certification Label showing the VIN.



F-150 VEHICLES - SERVICE PROCEDURE

Recommended Tool List For Replacement:

General Tools 2.7L GTDI Vehicles	General Equipment
1/2" Drive Power Tool	Flash Light
1/2" Drive Ratchet	
1/2" Drive Torque Wrench	
1/2" Drive 21 mm Socket	
1/4" Drive Power Tool	
1/4" Drive Ratchet	
1/4" Drive Torque Wrench	
1/4" Drive 7 mm Socket	
1/4" Drive 6 inch Extension	
Long Trim Tool	
Small Trim Tool	
General Tools 3.0L Diesel Vehicles	
1/2" Drive Power Tool	
1/2" Drive Torque Wrench	
1/2" Drive 21 mm Socket	
1/4" Drive Power Tool	
1/4" Drive Ratchet	
1/4" Drive Torque Wrench	
1/4" Drive 5.5 mm Socket	
Trim Tool	
General Tools 3.3L TiVCT Vehicles	
1/2" Drive Power Tool	
1/2" Drive Torque Wrench	
1/2" Drive 21 mm Socket	
Trim Tool	



F-150 VEHICLES - SERVICE PROCEDURE

Recommended Tool List For Replacement:

General Tools 3.5L GTDI And TiVCT Vehicles	General Equipment
1/2" Drive Power Tool	Flash Light
1/2" Drive Ratchet	
1/2" Drive Torque Wrench	
1/2" Drive 21 mm Socket	
1/4" Drive Power Tool	
1/4" Drive Ratchet	
1/4" Drive Torque Wrench	
1/4" Drive 7 mm, 8 mm and 5.5 mm Socket	
1/4" Drive 10 inch Extension	
Trim Tool	
Needle Nose Pliers	
General Tools 5.0L Vehicles	
3/8" Drive Power Tool	
3/8" Drive Torque Wrench	
3/8" Drive 21 mm Socket	
3/8" Drive 13 mm and 15 mm Socket	
3/8" Drive 15 mm Swivel Socket	
3/8" Drive 6 inch Extension	
1/4" Drive Power Tool	
1/4" Drive Ratchet	
1/4" Drive Torque Wrench	
1/4" Drive 10 mm and 13 mm Deep Socket	
Trim Tool	



Vehicles Equipped with 2.7L GTDI Engines

1. Remove the LH side wheel and tire assembly. Please follow Workshop Manual (WSM) procedures in Section 204-04A.
2. Remove the LH side fender splash shield. Please follow WSM procedures in Section 501-02.
3. Loosen and position aside the CAC tube. See Figure 1.

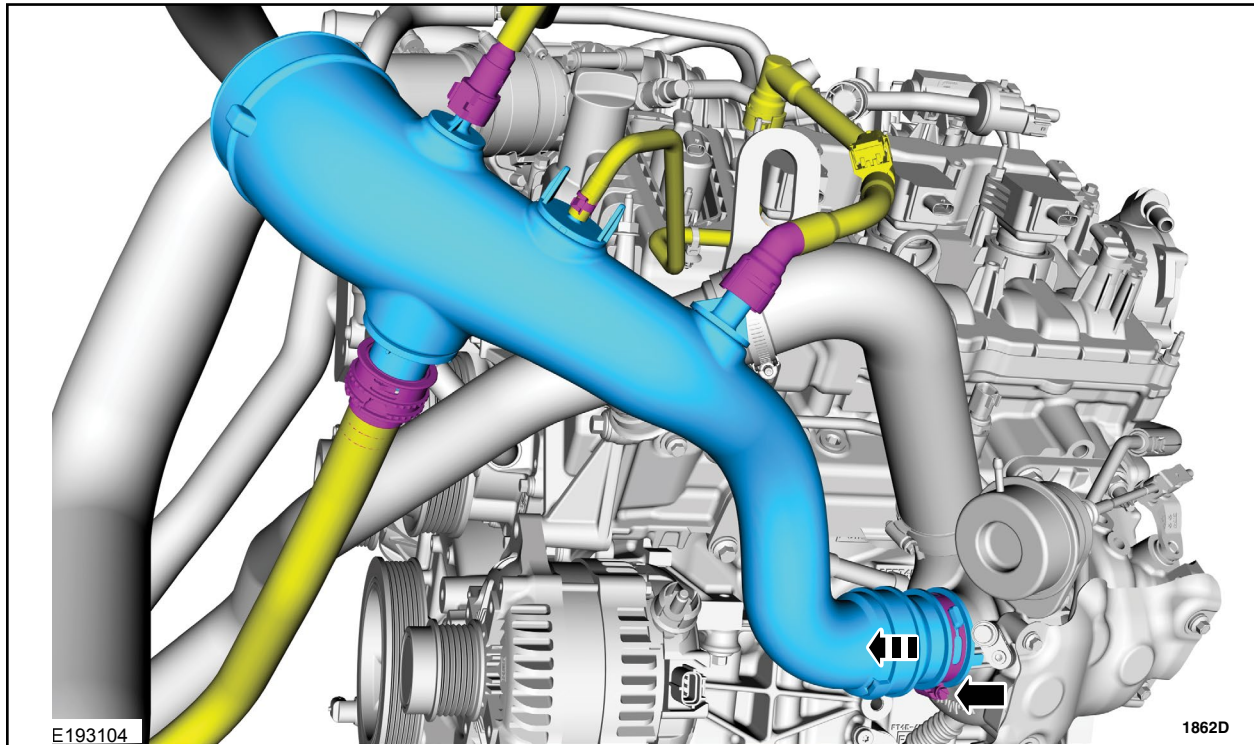

FIGURE 1

4. Disconnect the block heater electrical connector. See Figure 2.

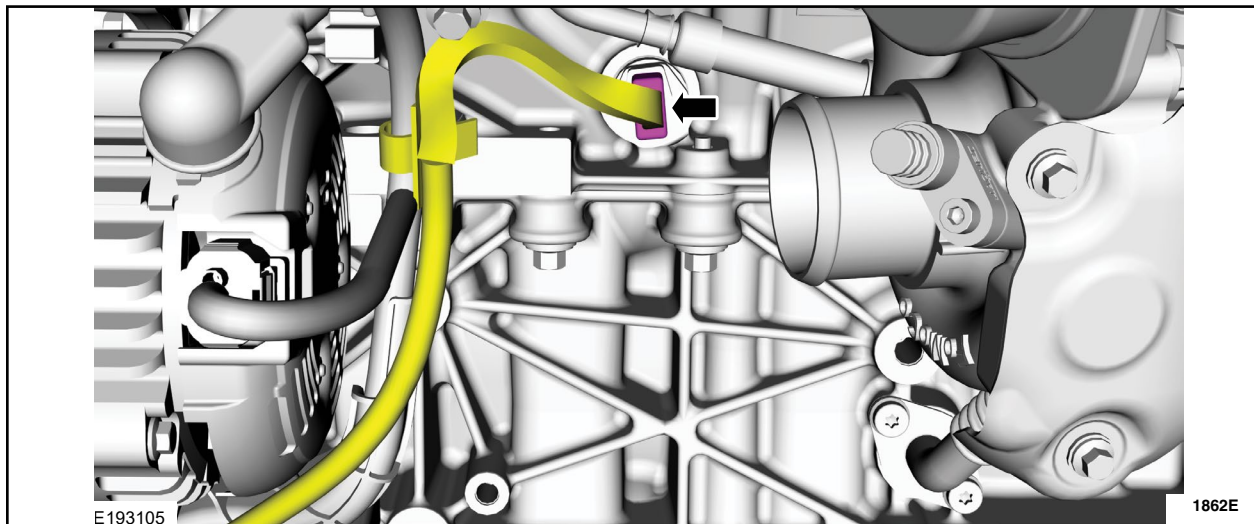

FIGURE 2



5. Remove and discard the wire assembly. See Figures 3a, 3b and 3c.
6. Apply XG-12 Motorcraft® Electrical Grease or equivalent to the *new* wire assembly in-line connector pins, on both sides of the wire assembly connector.
7. Connect the wire assembly in-line connector. See Figure 3b.
8. Install the *new* wire assembly in the vehicle following the same routing as the wire assembly that is being replaced. See Figures 3a, 3b and 3c.
9. Connect the *new* wire assembly to the block heater element. See Figure 2.

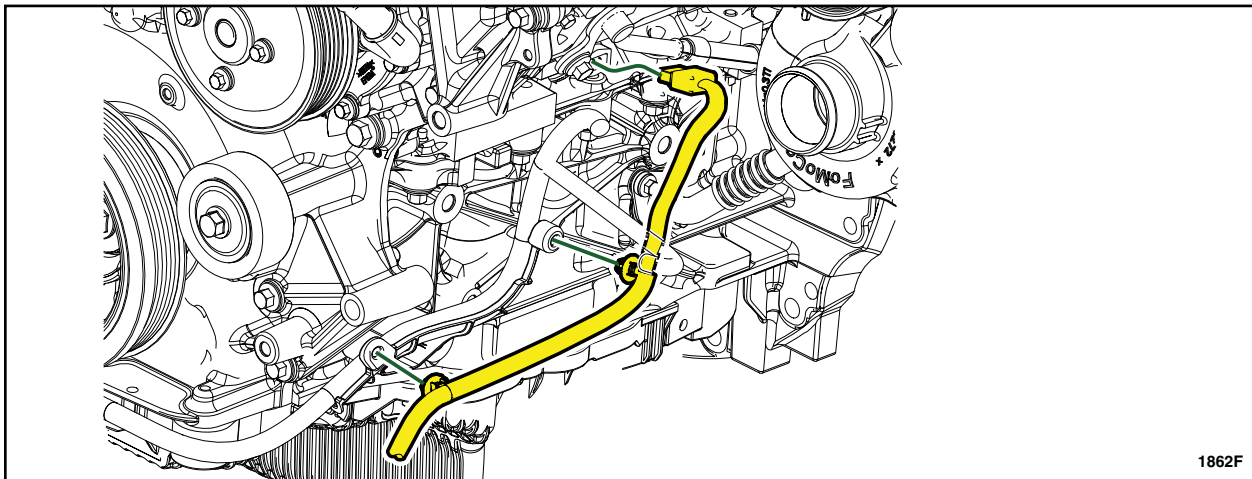

FIGURE 3a

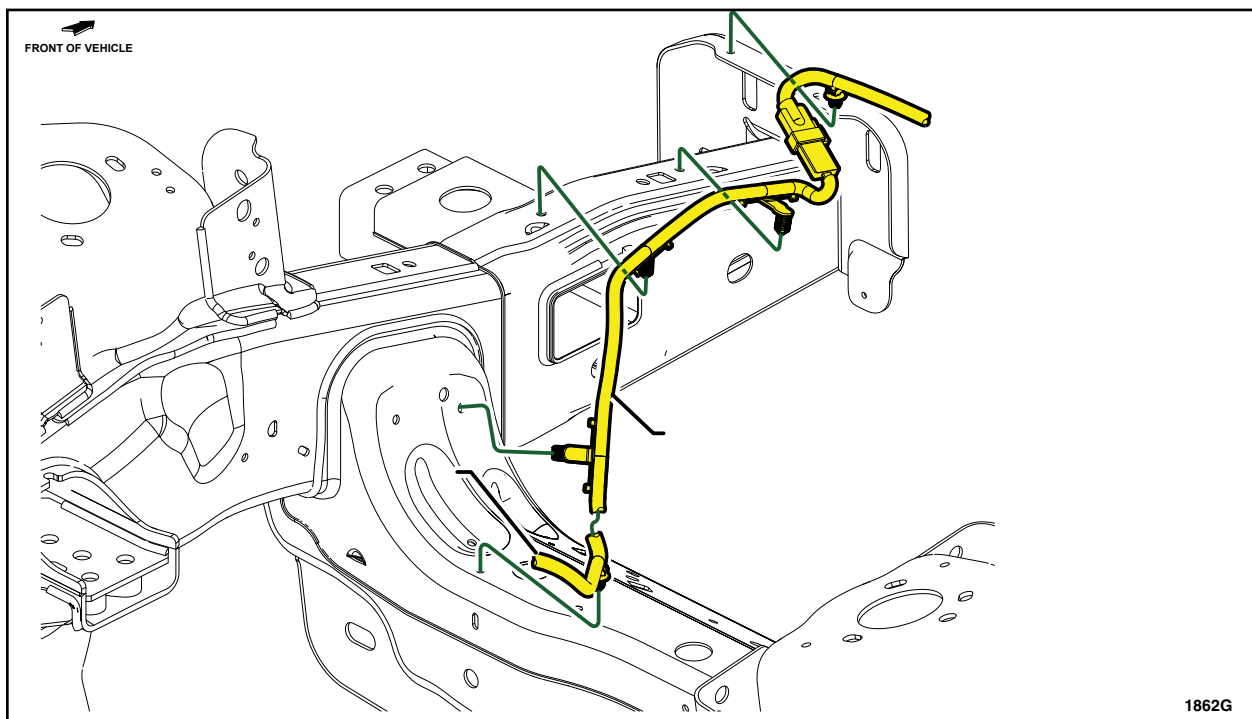

FIGURE 3b



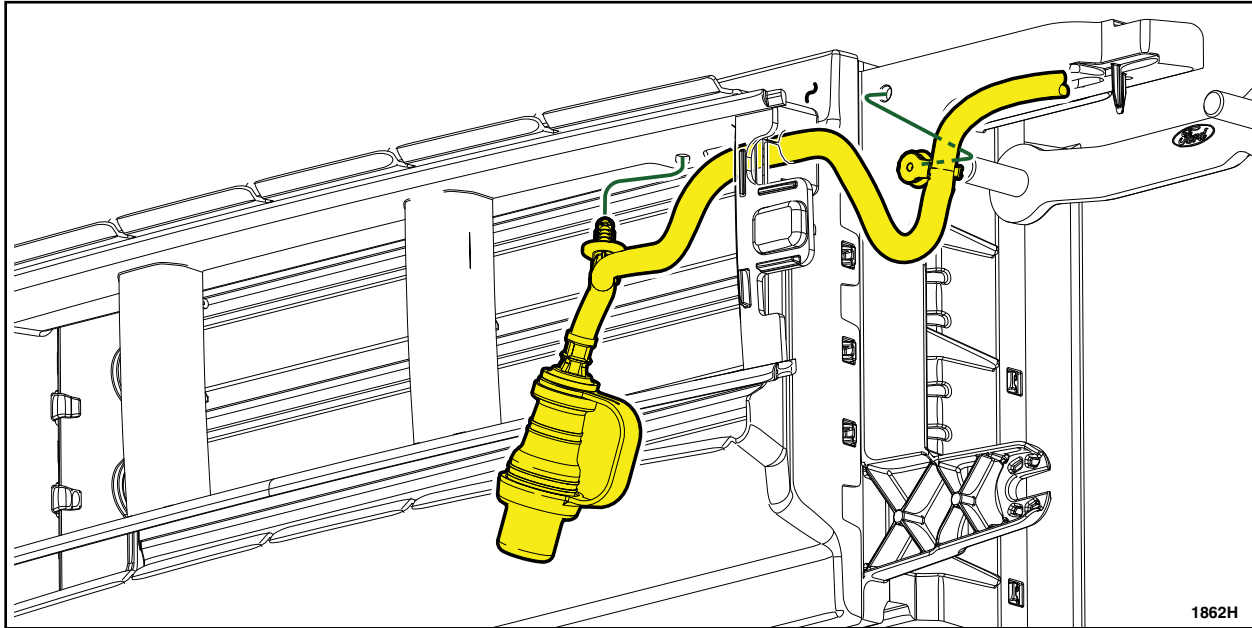

FIGURE 3c

10. Install the CAC tube. See Figure 1.

- Torque to 48 lb.in (5.4 Nm)

11. Install the LH side fender splash shield. Please follow WSM procedures in Section 501-02.

12. Install the LH side wheel and tire assembly. Please follow WSM procedures in Section 204-04A.



Vehicles Equipped with 3.0L Diesel Engines

1. Remove the LH side wheel and tire assembly. Please follow WSM procedures in Section 204-04A.
2. Remove the LH side fender splash shield. Please follow WSM procedures in Section 501-02.
3. Route the new wire assembly in the vehicle following the same routing as the wire assembly that is being replaced.
4. Disconnect the block heater electrical connector. See Figure 4.

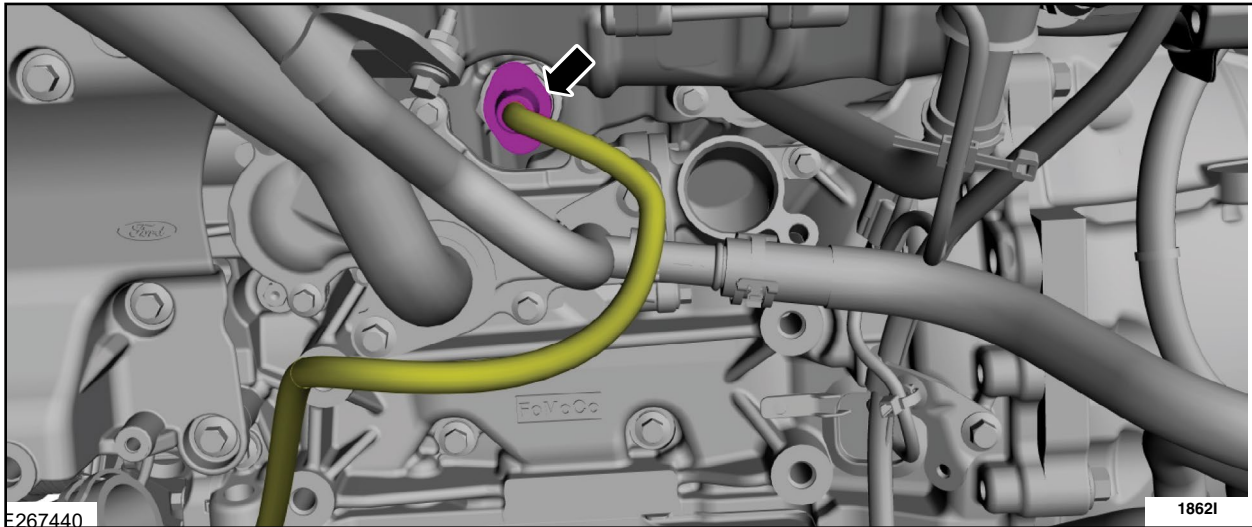

FIGURE 4

5. Remove and discard the wire assembly. See Figures 5a, 5b.
6. Apply XG-12 Motorcraft® Electrical Grease or equivalent to the *new* wire assembly in-line connector pins, on both sides of the wire assembly connector.
7. Connect the wire assembly in-line connector. See Figure 5b.
8. Install the *new* wire assembly in the vehicle following the same routing as the wire assembly that is being replaced. See Figures 5a, 5b.
9. Connect the *new* wire assembly to the block heater element. See Figure 4.



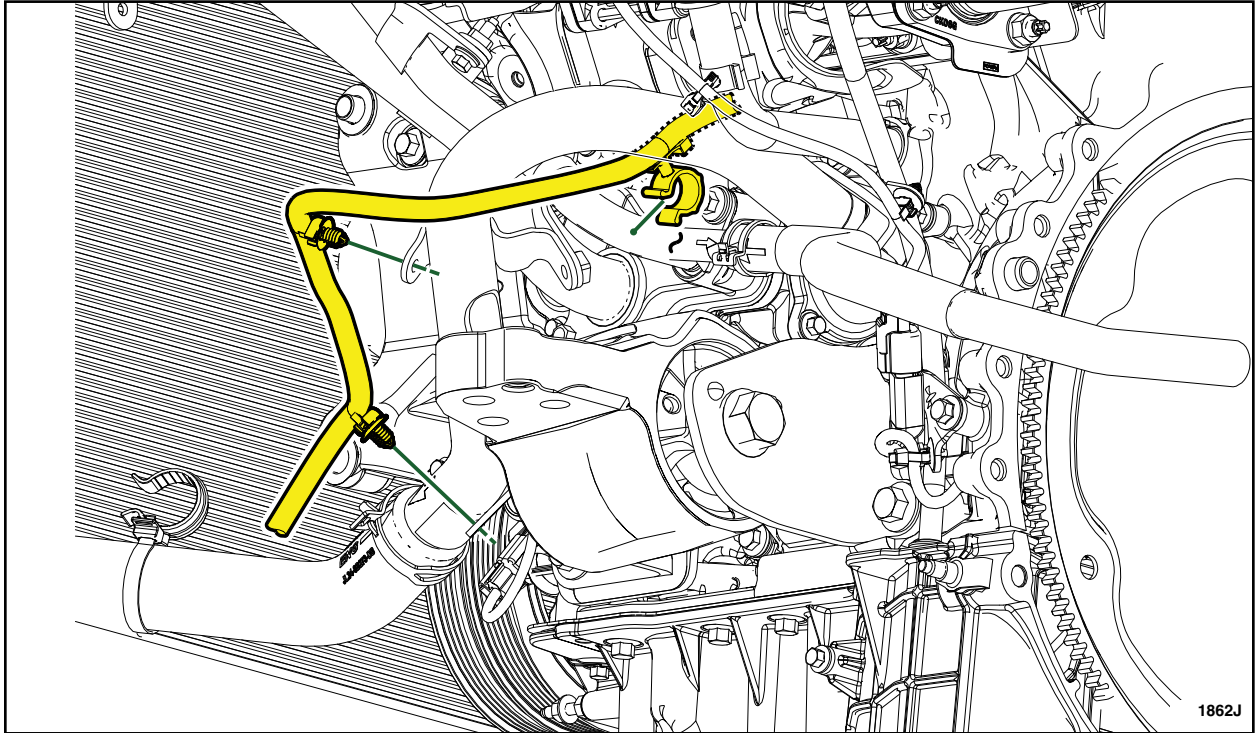

FIGURE 5a



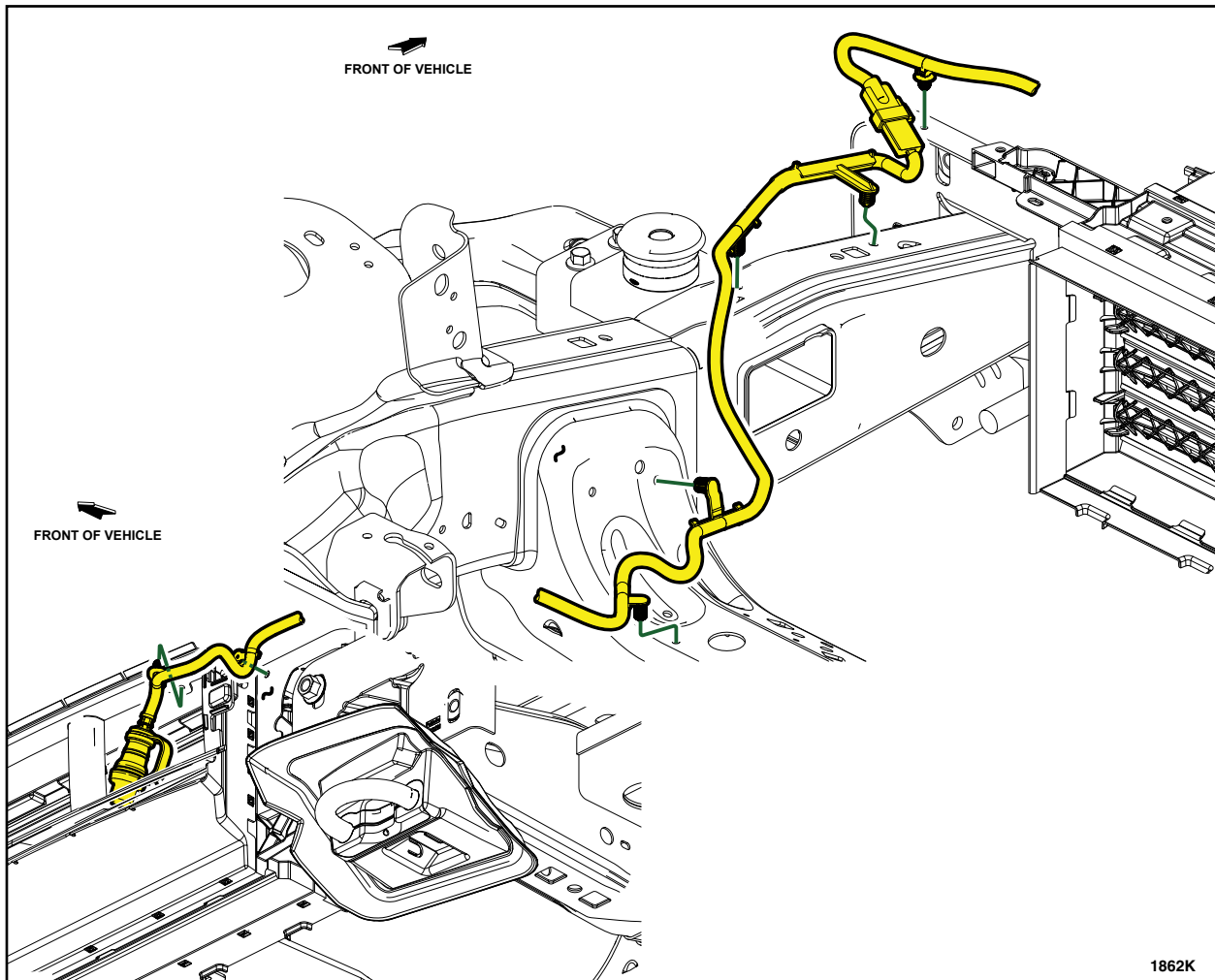

FIGURE 5b

10. Install the LH side fender splash shield. Please follow WSM procedures in Section 501-02.
11. Install the LH side wheel and tire assembly. Please follow WSM procedures in Section 204-04A.



Vehicles Equipped with 3.3L TiVCT Engines

1. Remove the LH side wheel and tire. Please follow WSM procedures in Section 204-04A.
2. Disconnect the block heater electrical connector. See Figure 6.

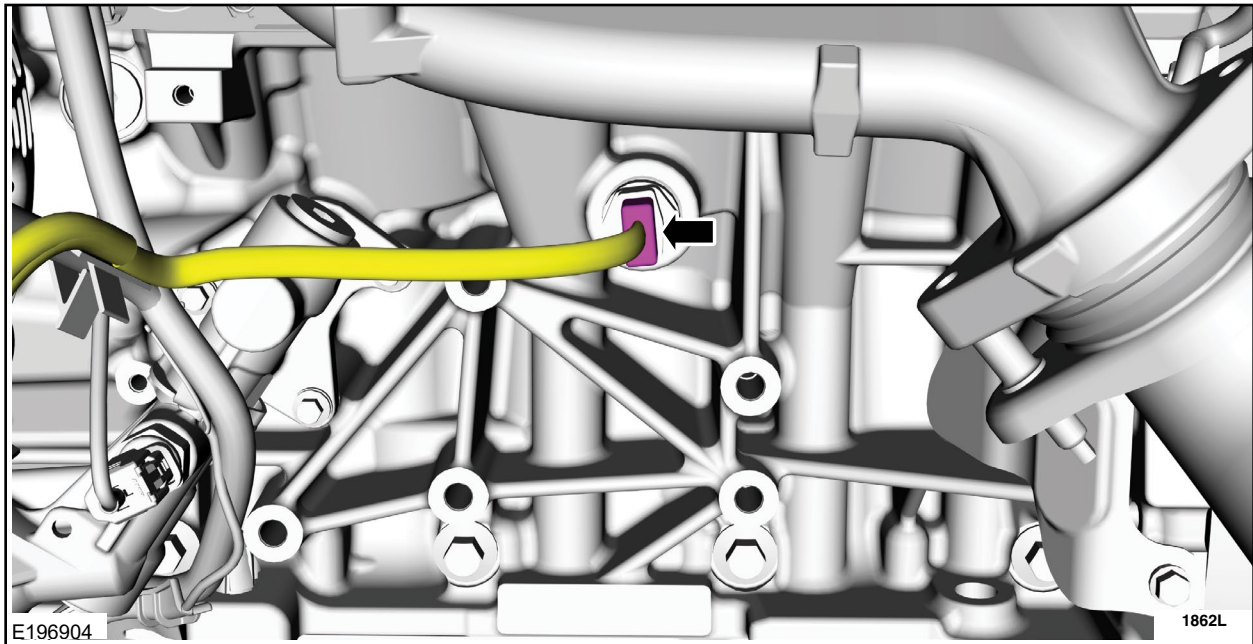

FIGURE 6

3. Remove and discard the wire assembly. See Figures 7a, 7b, 7c and 7d.
4. Apply XG-12 Motorcraft® Electrical Grease or equivalent to the *new* wire assembly in-line connector pins, on both sides of the wire assembly connector.
5. Connect the wire assembly in-line connector. See Figure 7c.
6. Install the *new* wire assembly in the vehicle following the same routing as the wire assembly that is being replaced. See Figures 7a, 7b, 7c and 7d.
7. Connect the *new* wire assembly to the block heater element. See Figure 6.
8. Install the LH side wheel and tire. Please follow WSM procedures in Section 204-04A.



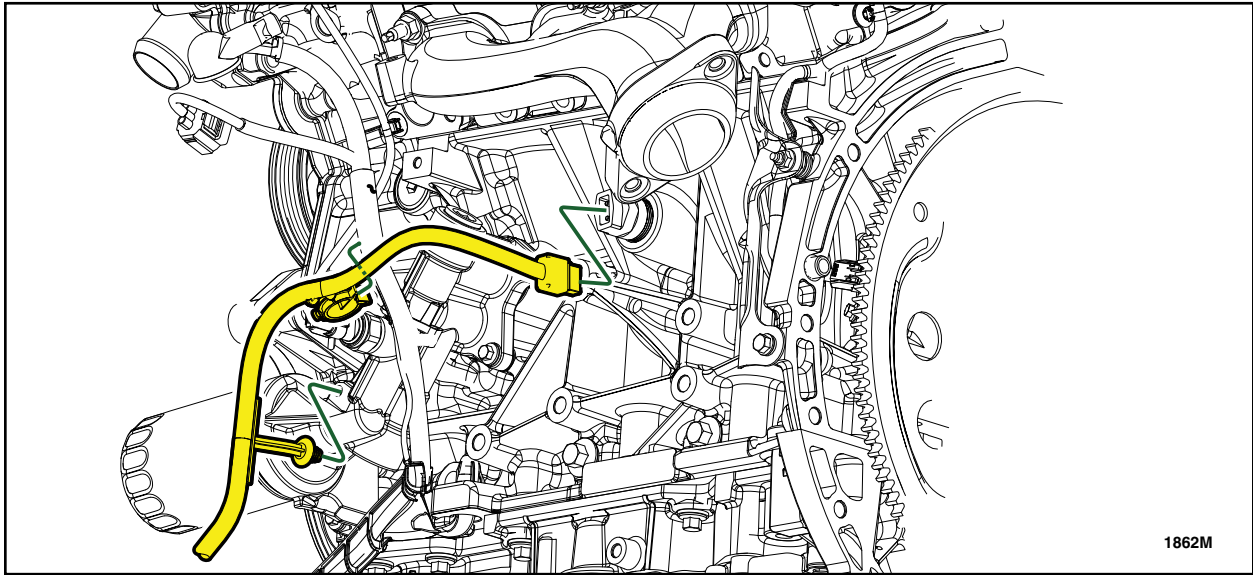

FIGURE 7a

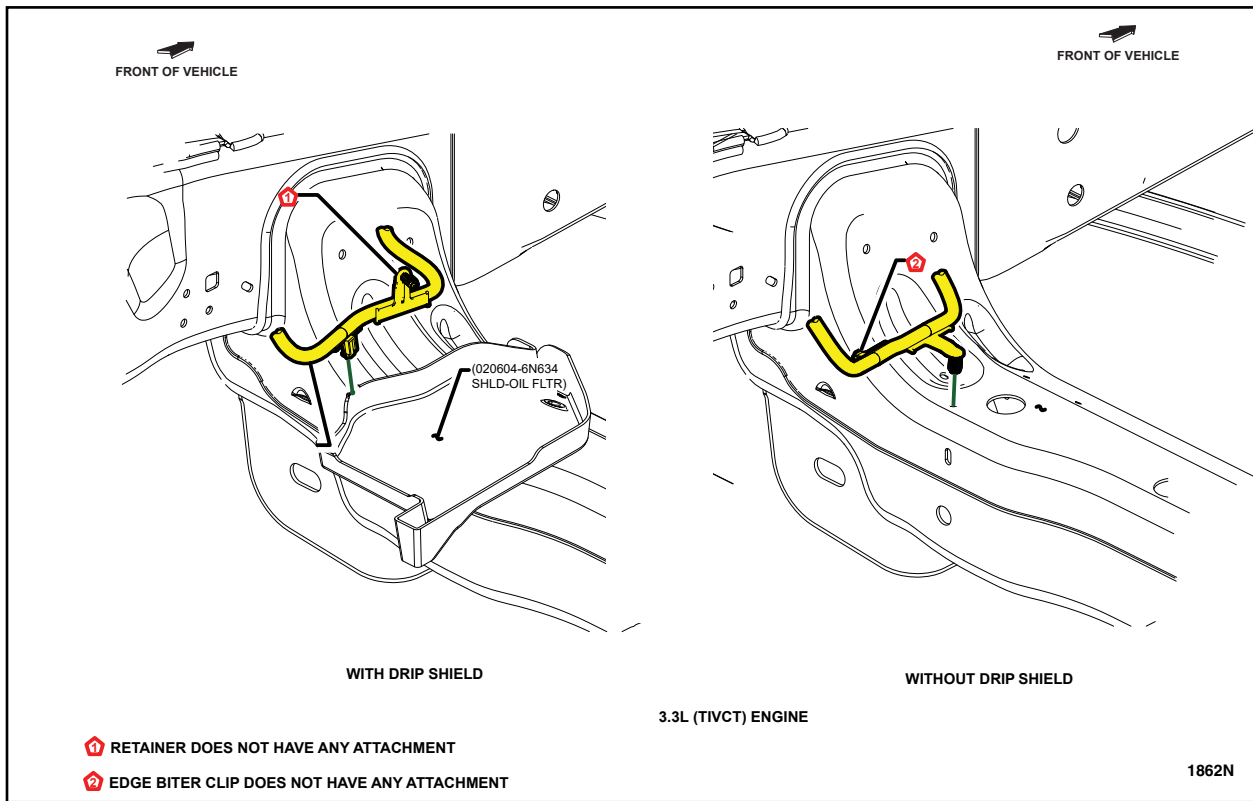

FIGURE 7b



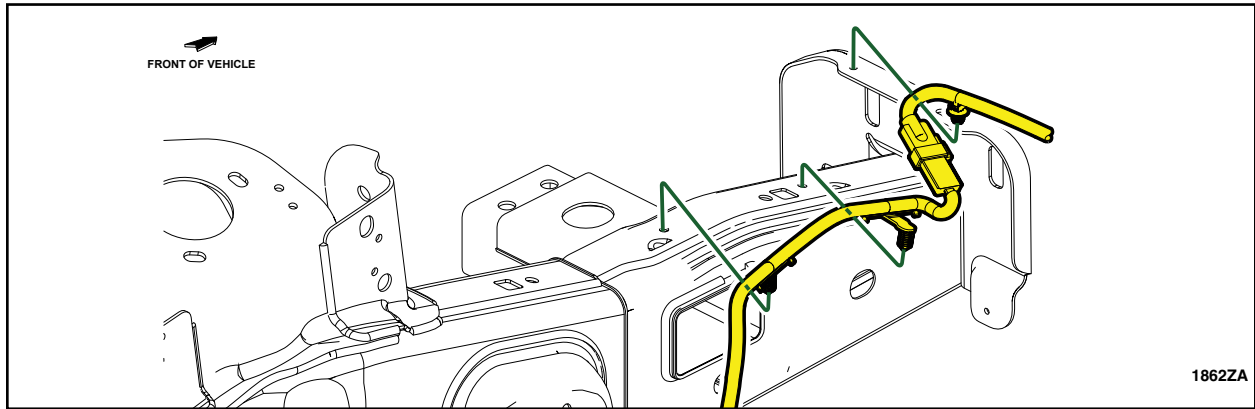

FIGURE 7c

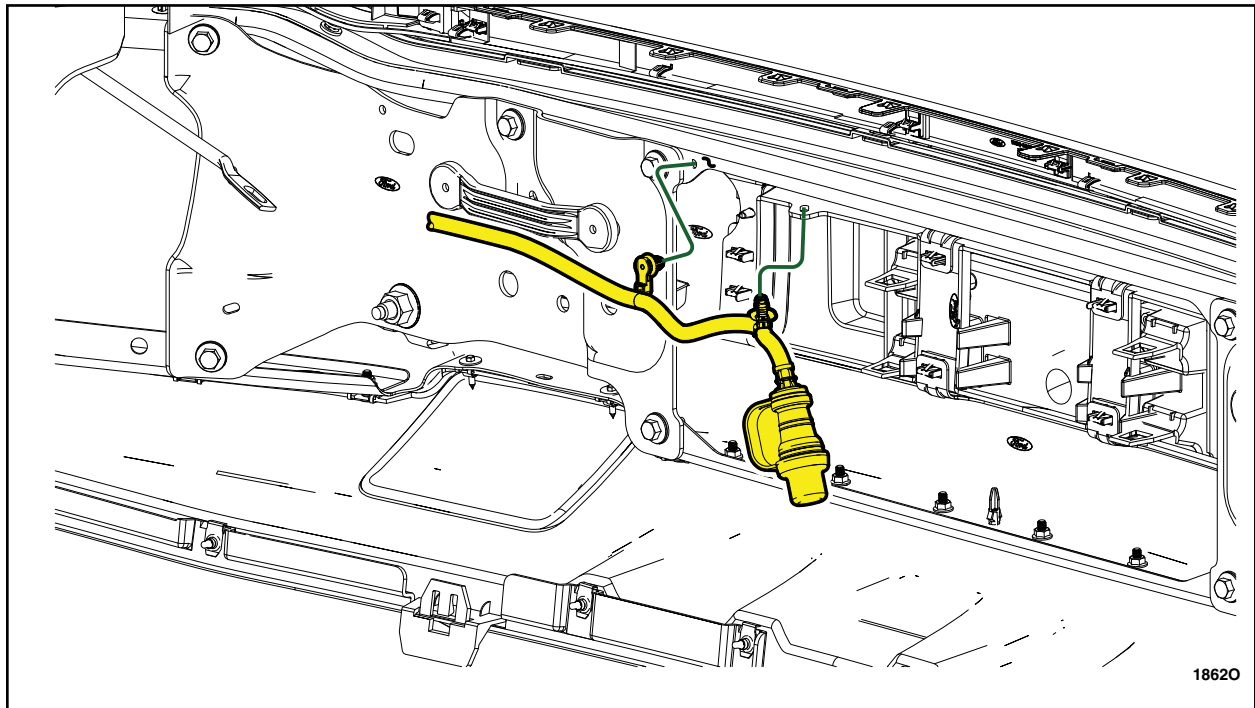

FIGURE 7d



Vehicles Equipped with 3.5L TiVCT Engines

1. Remove the LH side wheel and tire. Please follow WSM procedures in Section 204-04A.
2. Disconnect the block heater electrical connector. See Figure 8.

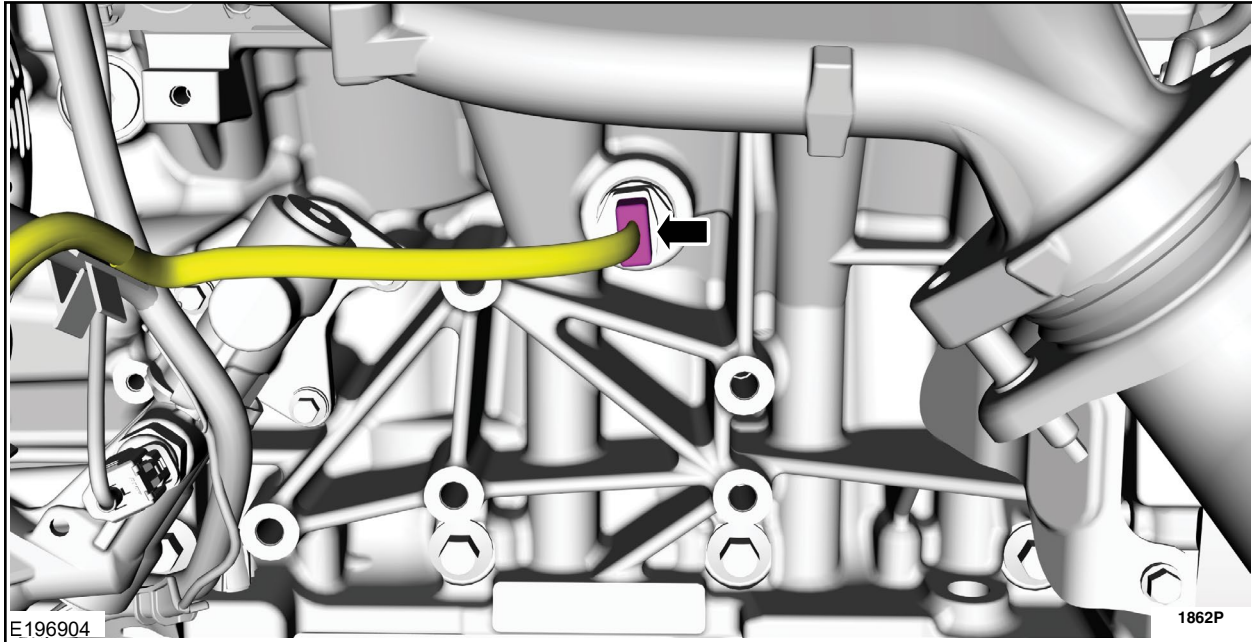
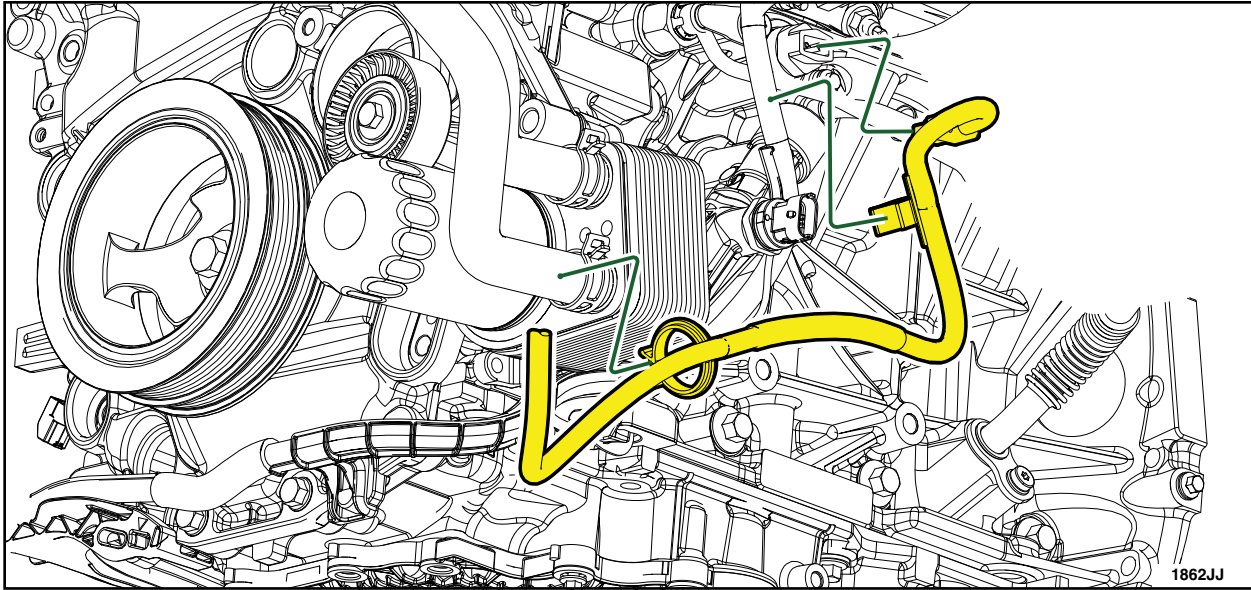

FIGURE 8

3. Remove and discard the wire assembly. See Figures 9a, 9b and 9c.
4. Apply XG-12 Motorcraft® Electrical Grease or equivalent to the *new* wire assembly in-line connector pins, on both sides of the wire assembly connector.
5. Connect the wire assembly in-line connector. See Figure 9a.
6. Install the *new* wire assembly in the vehicle following the same routing as the wire assembly that is being replaced. See Figures 9a, 9b and 9c.
7. Connect the *new* wire assembly to the block heater element. See Figure 8.
8. Install the left hand side wheel and tire assembly. Please follow WSM procedures in Section 204-04A.





1862JJ

FIGURE 9a

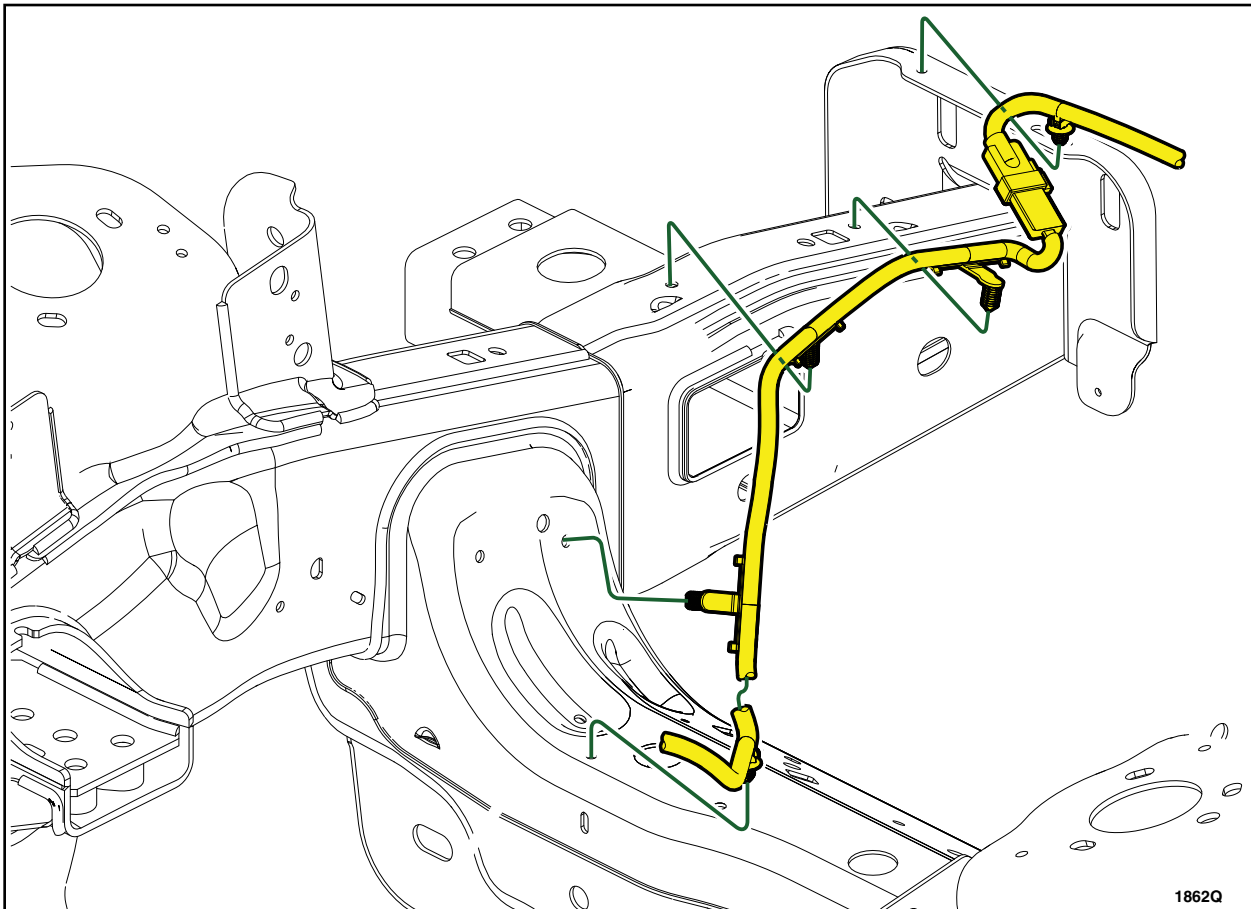

1862Q

FIGURE 9b



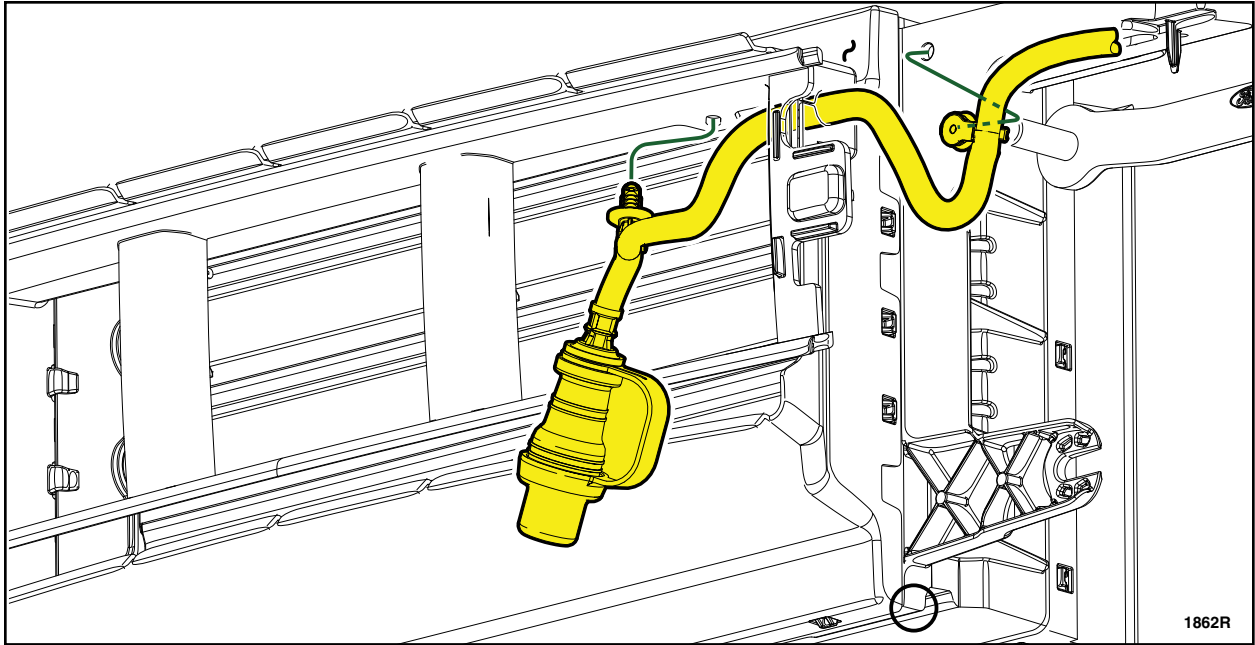

FIGURE 9c



Vehicles Equipped with 3.5L GTDI Engines

1. Remove the LH side wheel and tire. Please follow WSM procedures in Section 204-04A.
2. Remove the LH side fender splash shield. Please follow WSM procedures in Section 501-02.
3. Loosen and position aside the air cleaner outlet pipe LH. See Figure 10.

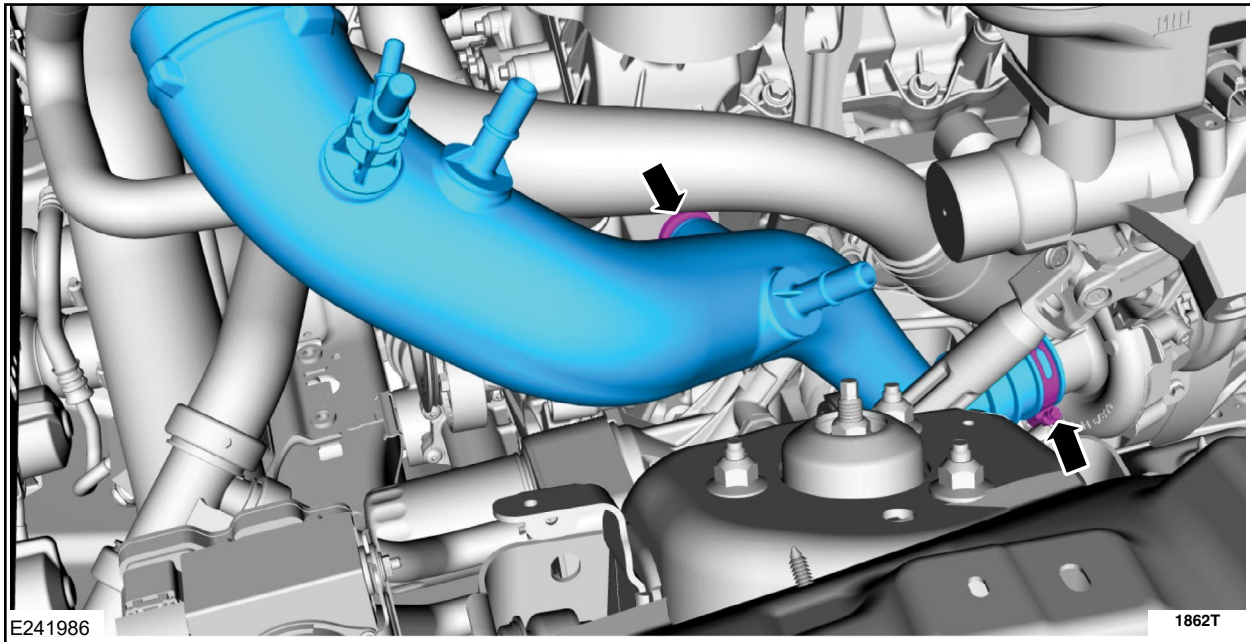

FIGURE 10

4. Disconnect the block heater electrical connector. See Figure 11.

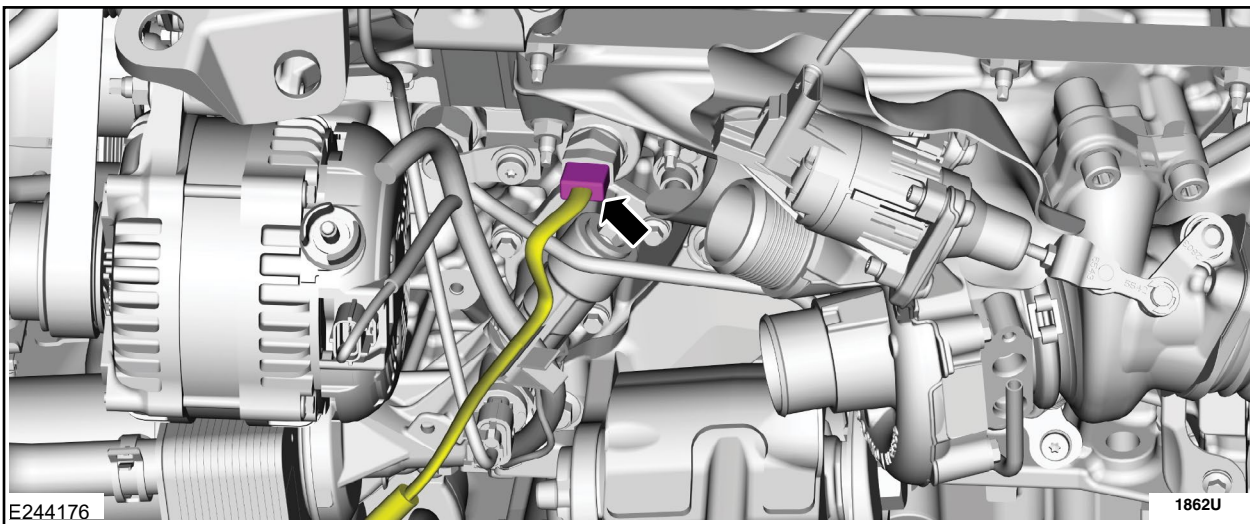

FIGURE 11



5. Remove and discard the wire assembly. See Figures 12a, 12b, 12c, 12d and 12e.
6. Apply XG-12 Motorcraft® Electrical Grease or equivalent to the *new* wire assembly in-line connector pins, on both sides of the wire assembly connector.
7. Connect the wire assembly in-line connector. See Figure 12b.
8. Install the *new* wire assembly in the vehicle following the same routing as the wire assembly that is being replaced. See Figures 12a, 12b, 12c, 12d and 12e.
9. Connect the *new* wire assembly to the block heater element. See Figure 11.
10. Install the air cleaner outlet pipe. See Figure 10.
 - Torque to 44 lb.in (5 Nm).
11. Install the LH side fender splash shield. Please follow WSM procedures in Section 501-02.
12. Install the LH side wheel and tire assembly. Please follow WSM procedures in Section 204-04A.

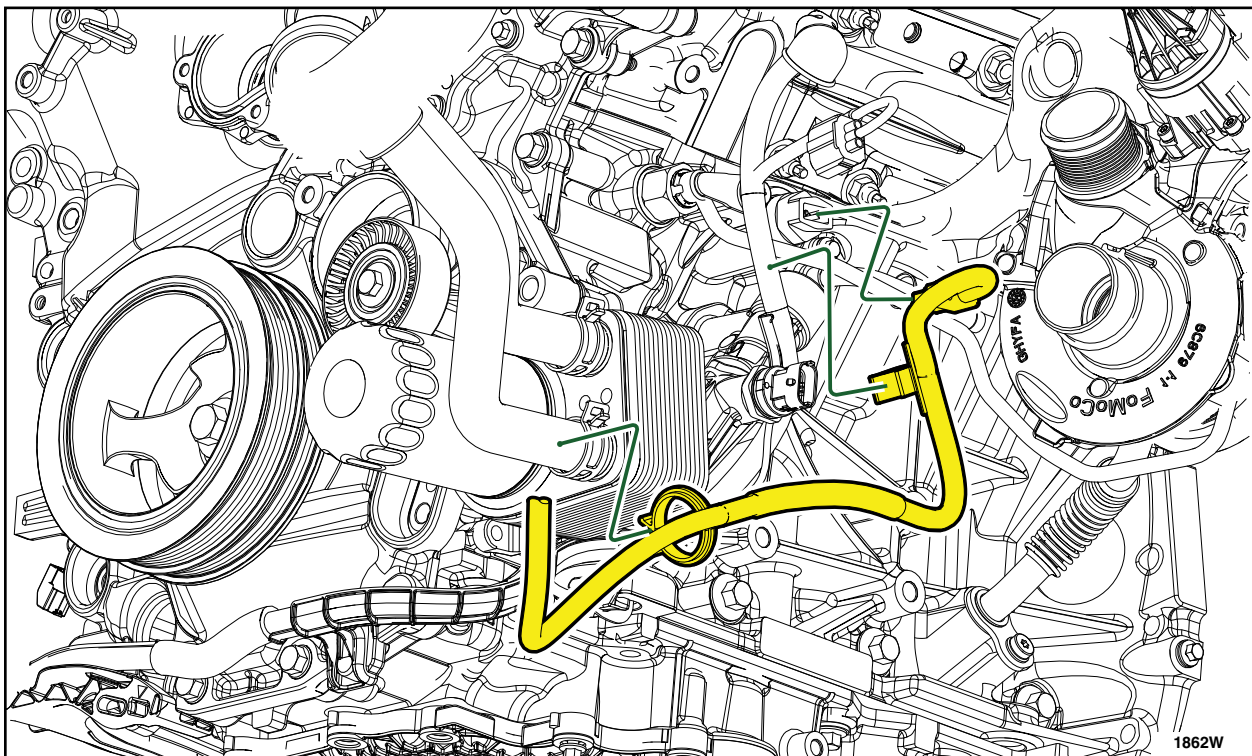

FIGURE 12a



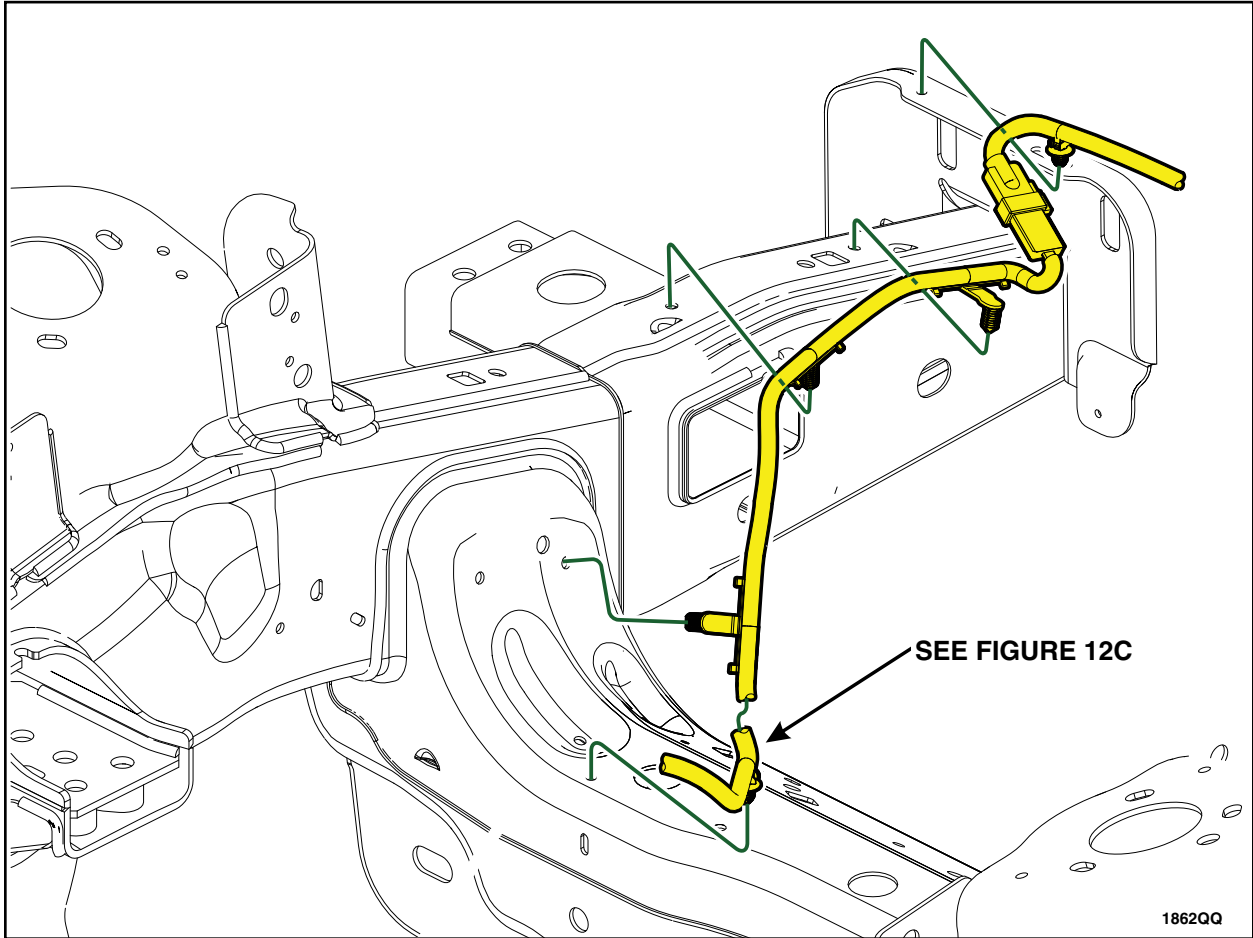

FIGURE 12b

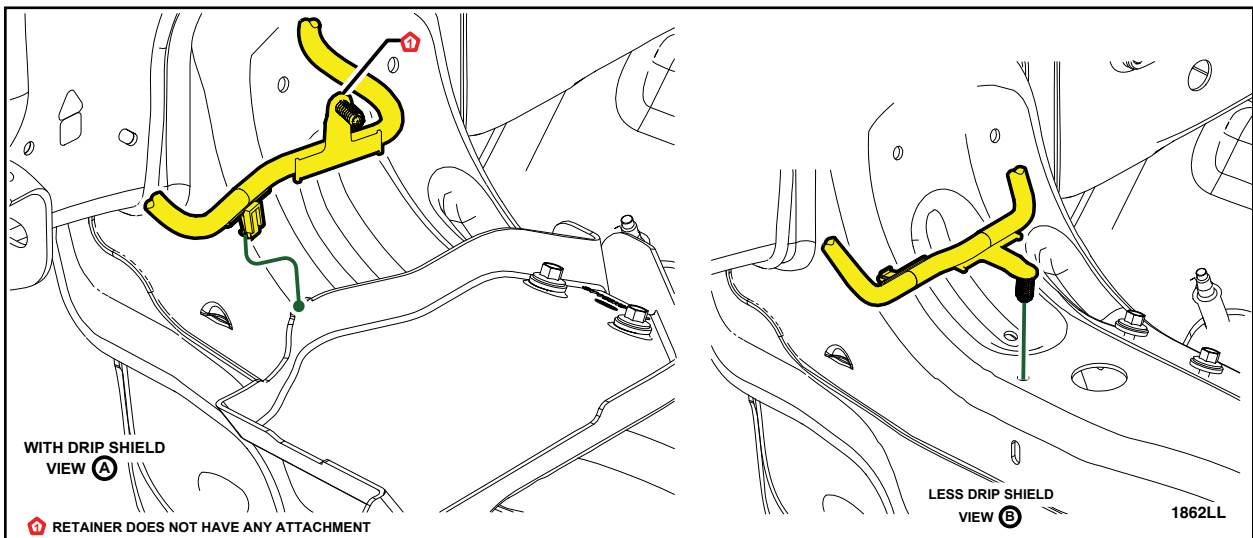

FIGURE 12c



NOTE: For all vehicles except Raptor.

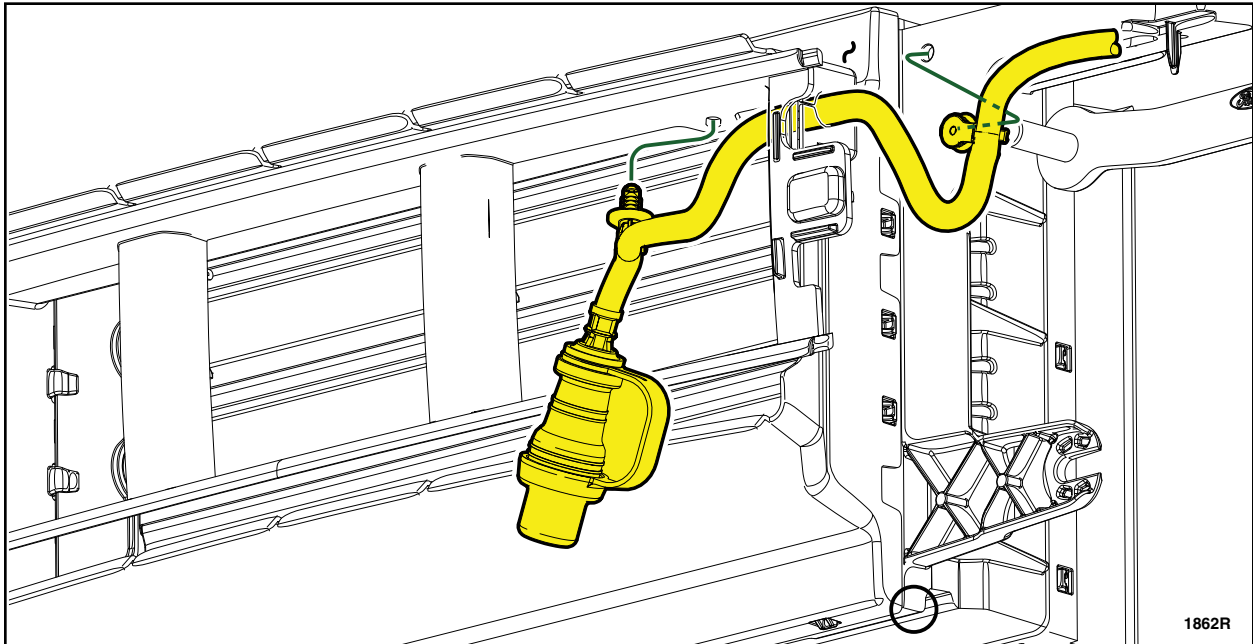

FIGURE 12d

NOTE: Figure 12e is for Raptor vehicles only.

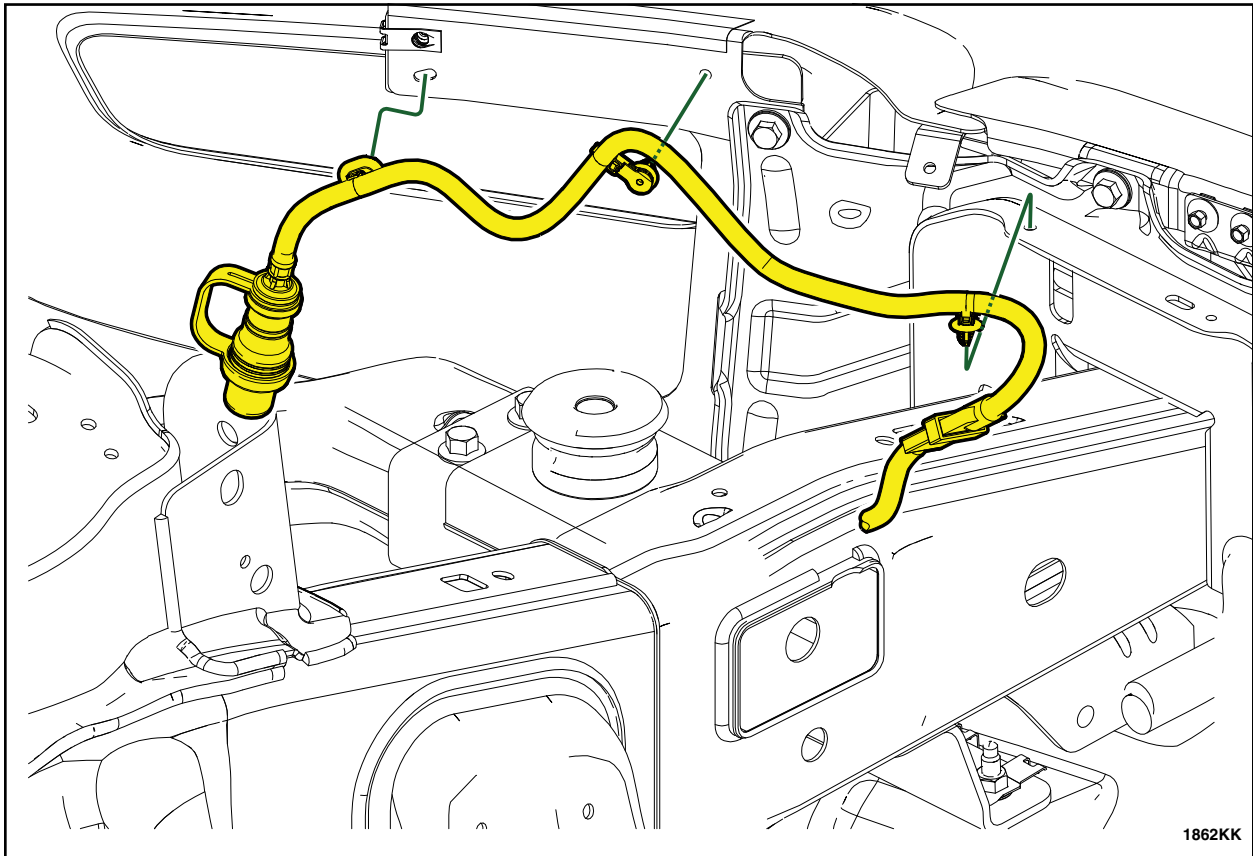

FIGURE 12e



Vehicles Equipped with 5.0L Engines

1. For 4X4 vehicles only, remove the generator. Please refer to WSM procedures in Section 414-02.
2. Disconnect the block heater electrical connector. See Figure 13.

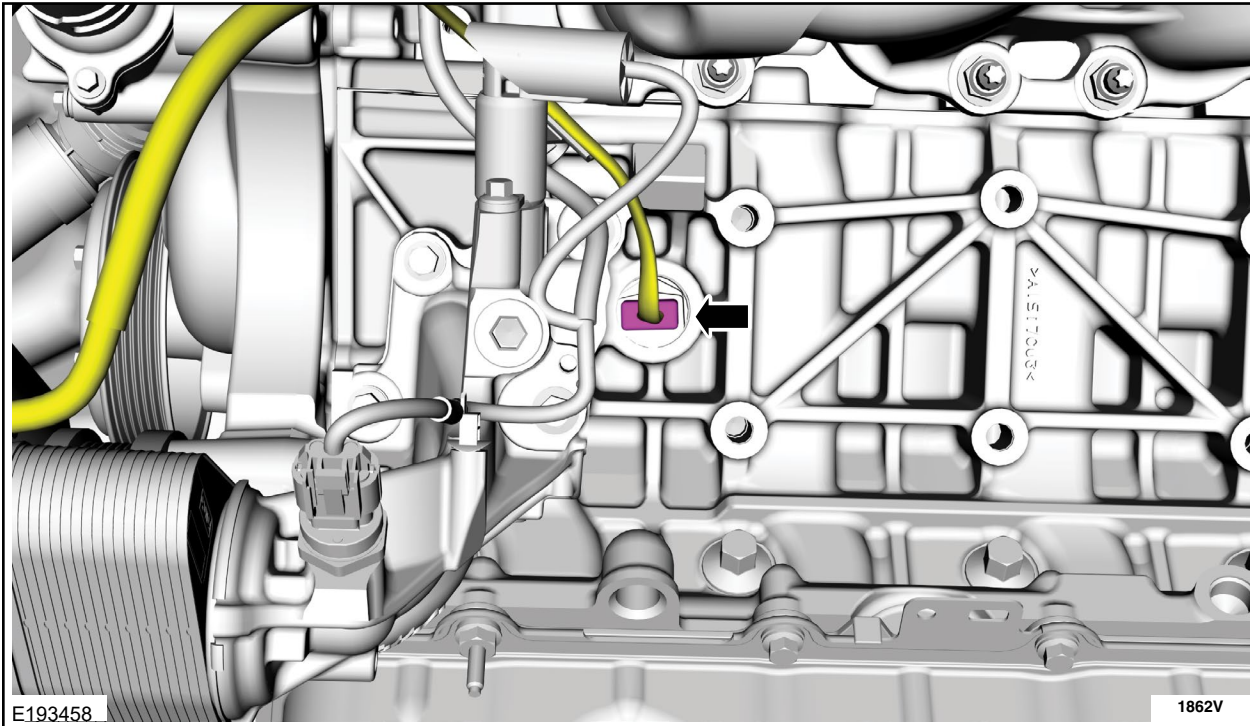

FIGURE 13

3. Remove and discard the wire assembly. See Figures 14a, 14b and 14c.
4. Apply XG-12 Motorcraft® Electrical Grease or equivalent to the *new* wire assembly in-line connector pins, on both sides of the wire assembly connector.
5. Connect the wire assembly in-line connector. See Figure 14b.
6. Install the *new* wire assembly in the vehicle following the same routing as the wire assembly that is being replaced. See Figures 14a, 14b and 14c.
7. Connect the new wire assembly to the block heater element. See Figure 13.
8. Install the alternator. Please refer to WSM procedures in Section 414-02.



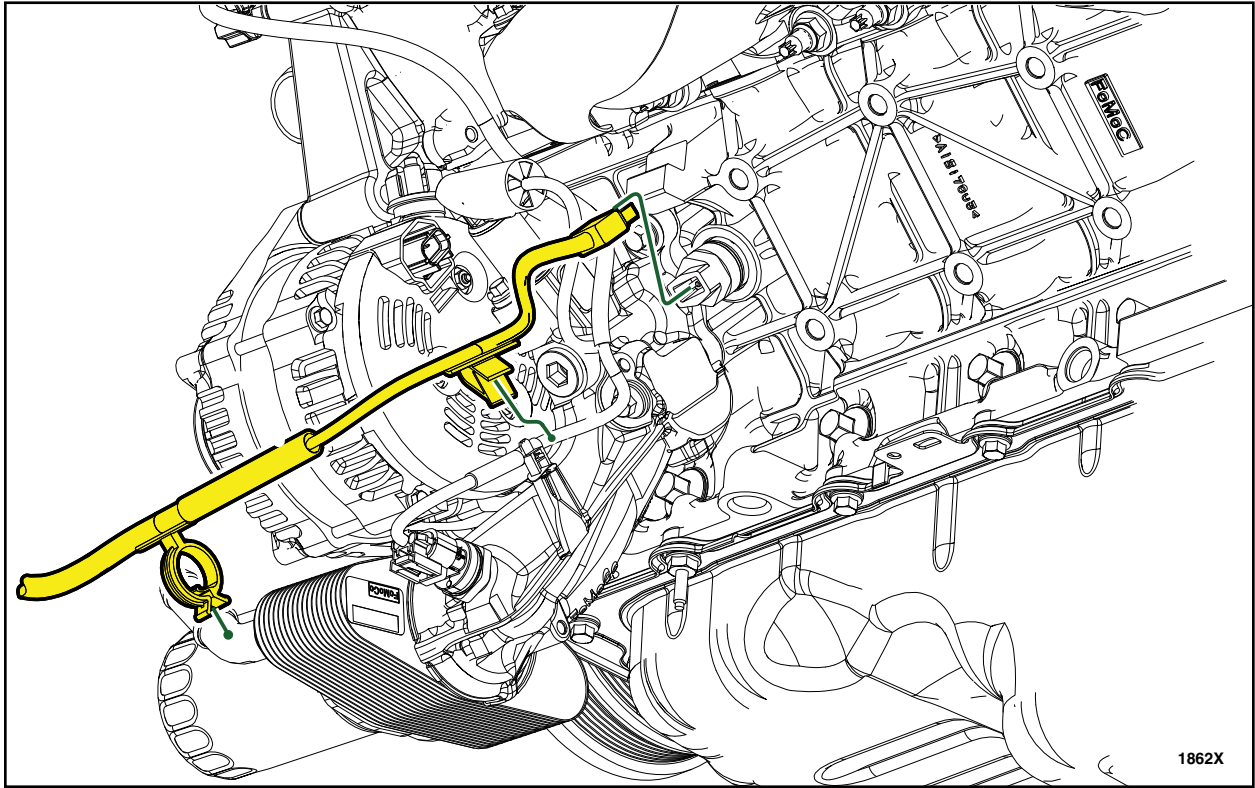

FIGURE 14a



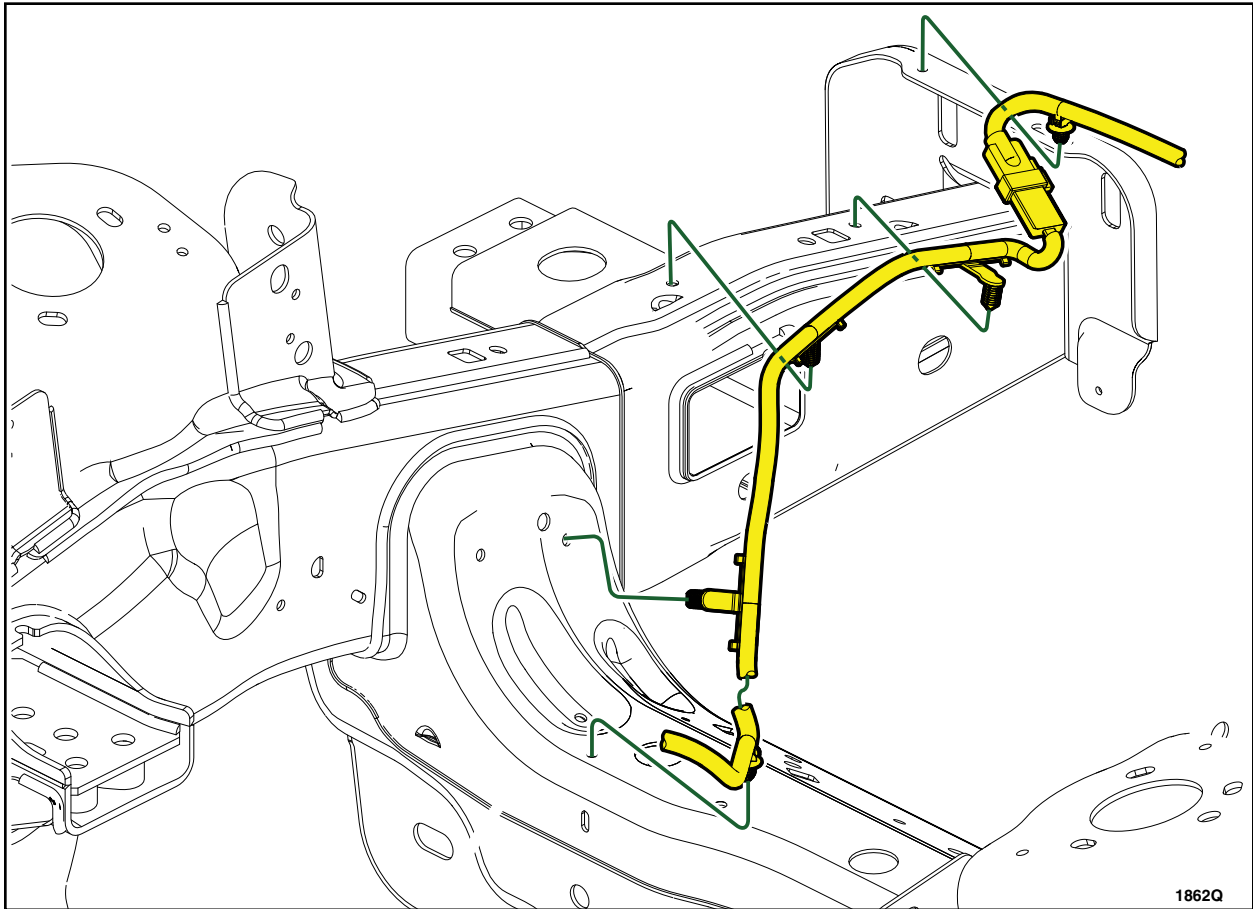

FIGURE 14b

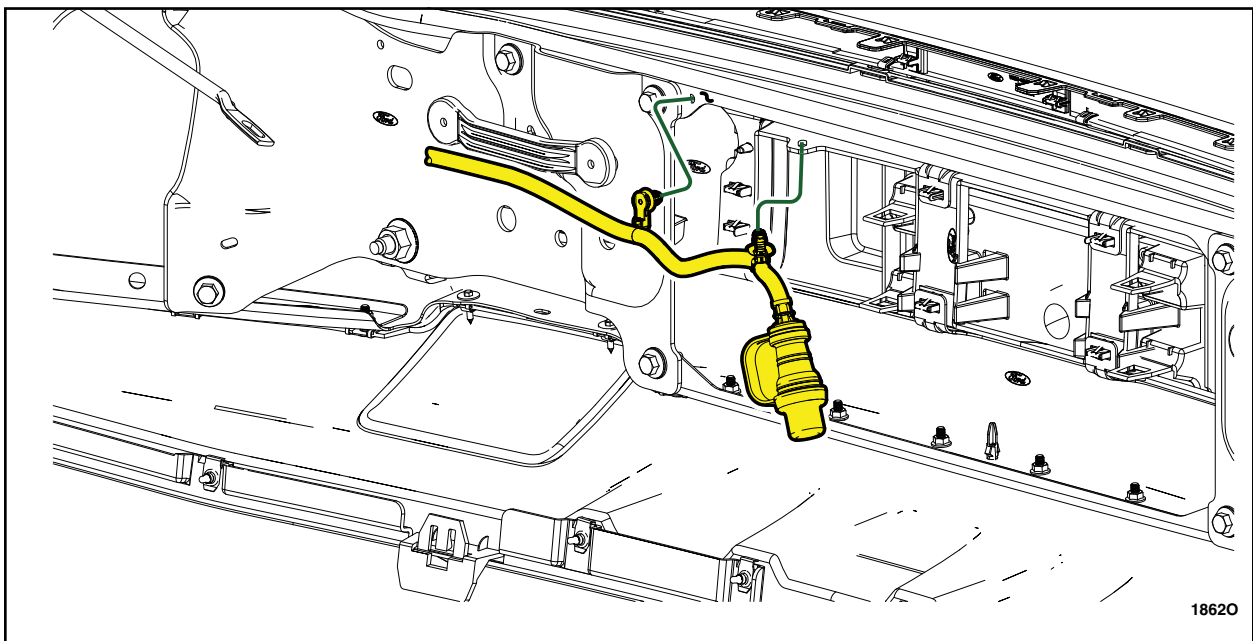

FIGURE 14c



CERTAIN 2015 - 2019 MODEL YEAR F-150 AND 2017 – 2019 MODEL YEAR F-SUPER DUTY VEHICLES EQUIPPED WITH ENGINE BLOCK HEATERS — ENGINE BLOCK HEATER WIRE ASSEMBLY WATER INTRUSION/CORROSION

OVERVIEW

In some of the affected vehicles, the engine block heater wire assembly may be susceptible to excess water intrusion or corrosion in the in-line connector. While the vehicle is parked and the block heater is plugged in, an inoperative engine block heater, tripping of household breakers or GFCI equipped outlets, and/or resistive short may result. A resistive short may increase the risk of overheated or melted wiring, and/or fire. Before demonstrating or delivering any new in-stock vehicles involved in this recall, dealers are to inspect the engine block-heater wire assembly in-line connector for water intrusion and/or corrosion:

SERVICE PROCEDURE

- Pass, apply electric grease, no part replacement required.
- Failed, part is available, replace engine block heater wire assembly, and apply electric grease to in-line connector on new wire assembly before installing on vehicle.
- Failed, no parts available, dry in-line connector, apply grease, use labor operation 18S45BB as an interim repair, and provide a copy of Attachment VI Customer Information Sheet to customer.

This service must be performed on all affected vehicles at no charge to the vehicle owner.

At this time, parts are not available to repair all vehicles; however, less than 6% of the affected vehicle population is expected to require engine block heater wire assembly replacement. Until parts are available to repair all vehicles, dealers may submit an approval request, with photos of corrosion in the in-line connector, to the SSSC to authorize repairs on customer-owned vehicles in extenuating circumstances and unsold vehicles with a signed sales contact. Parts to repair all vehicles are expected to be available first quarter 2019, at which time this bulletin will be supplemented.

Over – The – Counter Engine Block Heater Kit Sales

Dealers are to review their part sales records and contact any customers to whom an affected genuine Ford engine block heater kit has been sold. Give the customer a copy of the Owner Notification Letter and schedule a service date when parts are available.

Please contact the Special Service Support Center (SSSC) via the Web Contact Site, using a VIN specific Non-Involved Vehicle Request to request adding an affected VIN to this safety recall prior to performing this service action. Please include an image of the genuine Ford Part Number label with the engine block heater kit installed and a photo of the Vehicle Certification Label showing the VIN.



F-SUPER DUTY VEHICLES - SERVICE PROCEDURE

Recommended Tool List For Replacement:

General Tools 6.2L Vehicles	General Equipment
15" Push Pin Removal Tool	Flash Light
General Tools 6.8L Vehicles	
15" Push Pin Removal Tool	
General Tools 6.7L Vehicles	
1/2" Drive Power Tool	
1/2" Drive 21 mm Socket	
1/2" Drive Torque Wrench	
1/4" Drive Power Tool	
1/4" Drive Ratchet	
1/4" Drive Torque Wrench	
1/4" Drive 5.5 mm Socket	
1/4" Drive T30 Torx Socket	
Trim Tool	
Push Pin Removal Tool	



Vehicles Equipped with 6.2L Engines

1. Disconnect the block heater electrical connector. See Figure 1.

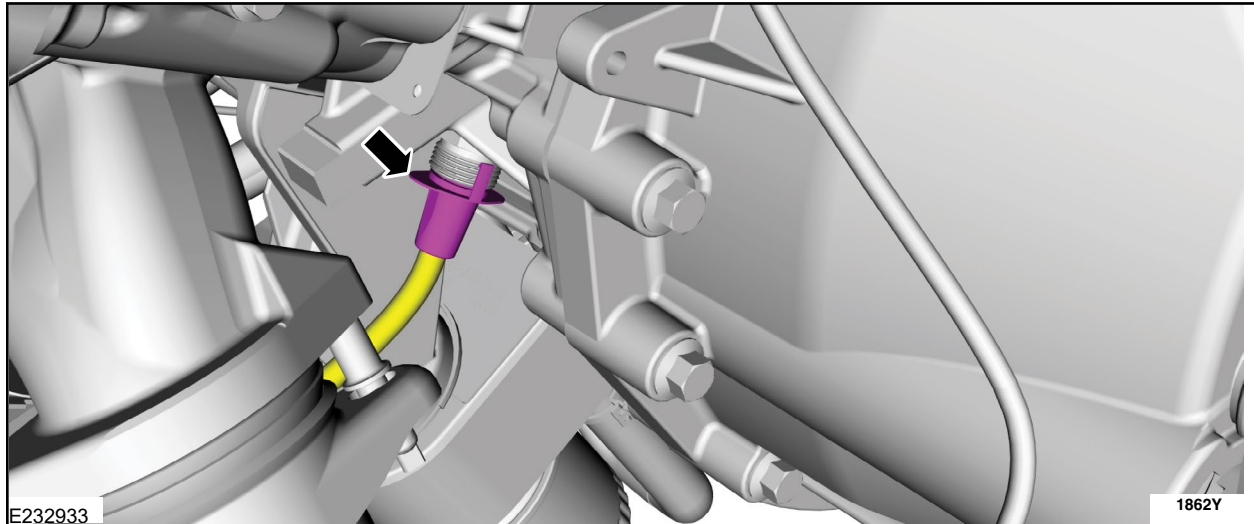

FIGURE 1

2. Remove and discard the wire assembly. See Figures 2a, 2b and 2c.
3. Apply XG-12 Motorcraft® Electrical Grease or equivalent to the *new* wire assembly in-line connector pins, on both sides of the wire assembly connector.
4. Connect the wire assembly in-line connector. See Figure 2c.
5. Install the *new* wire assembly in the vehicle following the same routing as the wire assembly that is being replaced. See Figures 2a, 2b and 2c.
6. Connect the *new* wire assembly to the block heater element. See Figure 1.



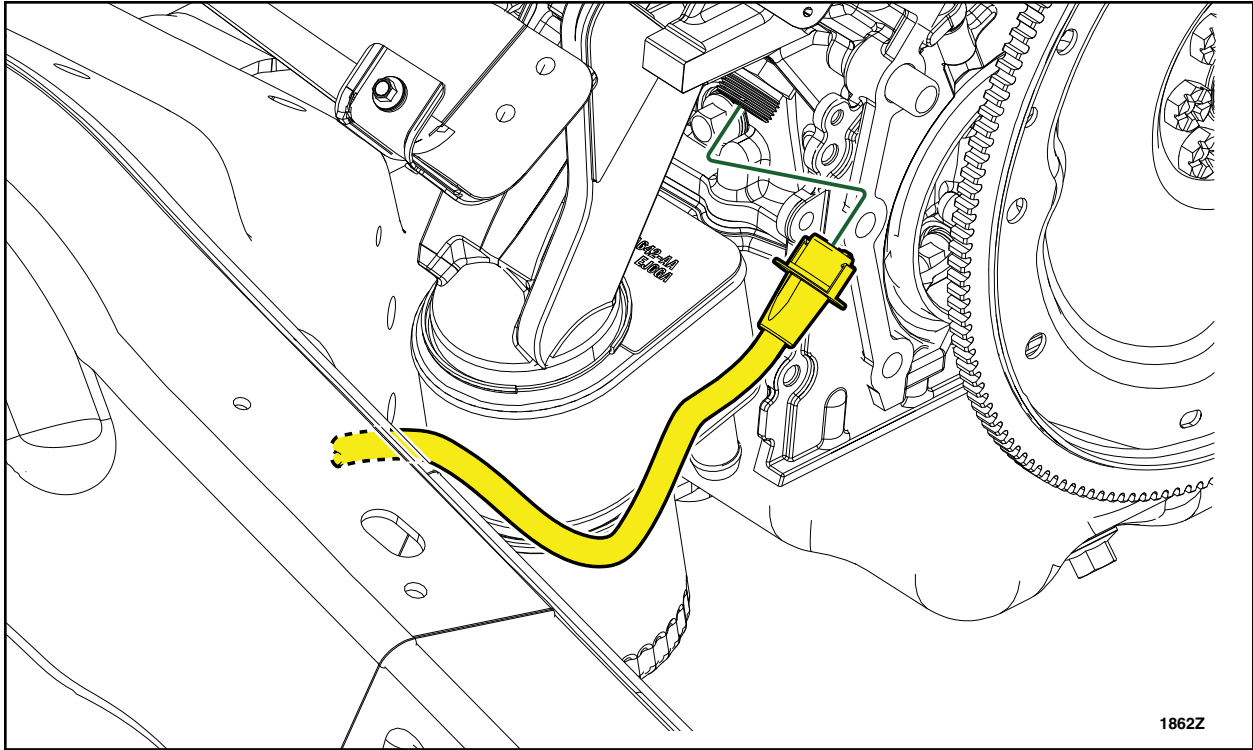

FIGURE 2a

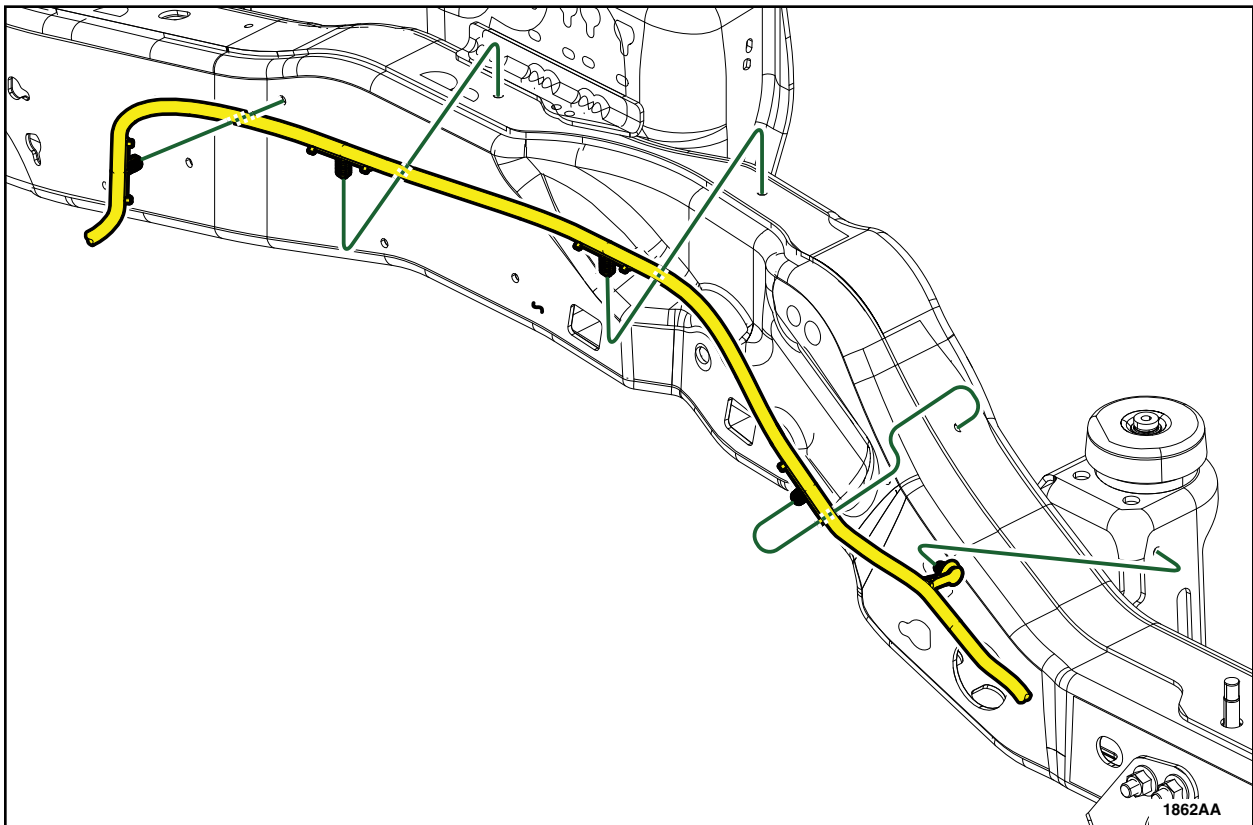

FIGURE 2b



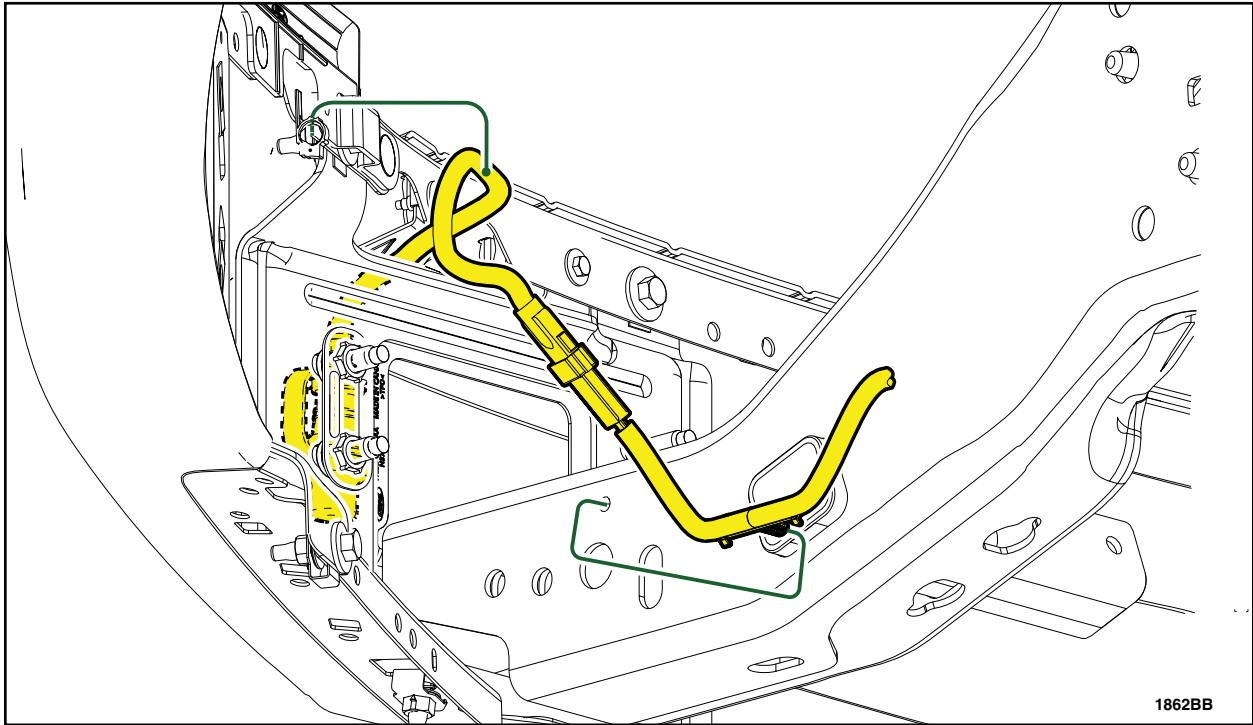

FIGURE 2c



Vehicles Equipped with 6.7L Engines

1. Remove the LH side wheel and tire. Please follow Workshop Manual (WSM) procedures in Section 204-04A.
2. For F-450/550 vehicles only, remove the LH front fender moulding. Please follow WSM procedures in Section 501-08.
3. Remove the LH side fender splash shield. Please follow WSM procedures in section 501-02.
4. Disconnect the block heater electrical connector. See Figure 3.

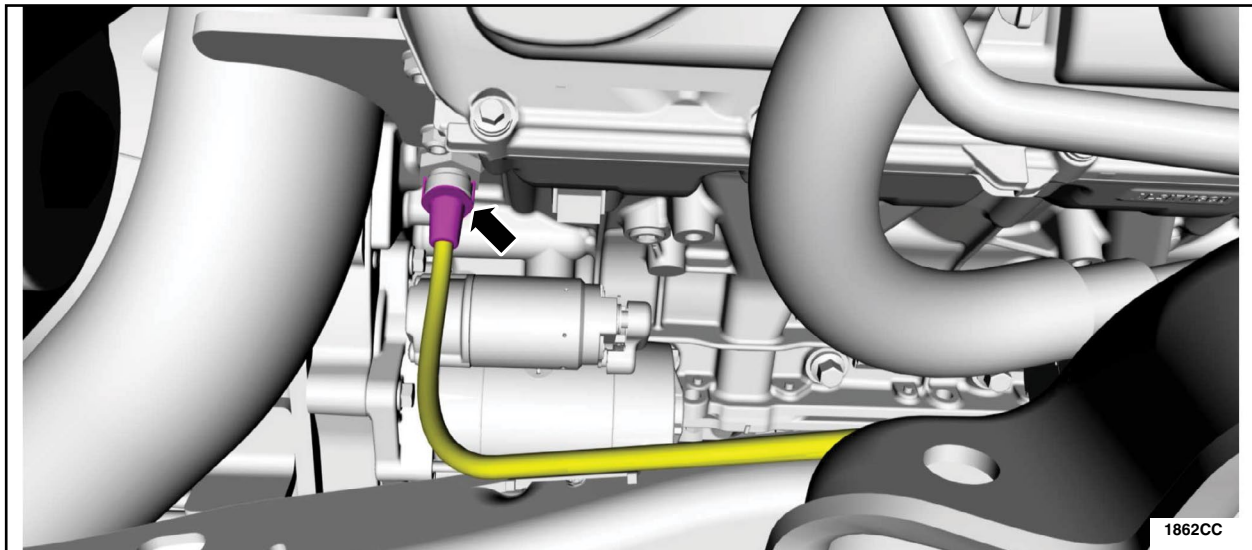

FIGURE 3

5. Remove and discard the wire assembly. See Figures 4a, 4b and 4c.
6. Apply XG-12 Motorcraft® Electrical Grease or equivalent to the *new* wire assembly in-line connector pins, on both sides of the wire assembly connector.
7. Connect the wire assembly in-line connector. See Figure 4c.
8. Install the *new* wire assembly in the vehicle following the same routing as the wire assembly that is being replaced. See Figures 4a, 4b and 4c.
9. Connect the *new* wire assembly to the block heater element. See Figure 3.
10. Install the LH side fender splash shield. Please follow WSM procedures in Section 501-02.
11. For F-450/550 vehicles only, install the LH front fender moulding. Please follow WSM procedures in Section 501-08.
12. Install the LH side wheel and tire assembly. Please follow Workshop Manual (WSM) procedures in Section 204-04A.



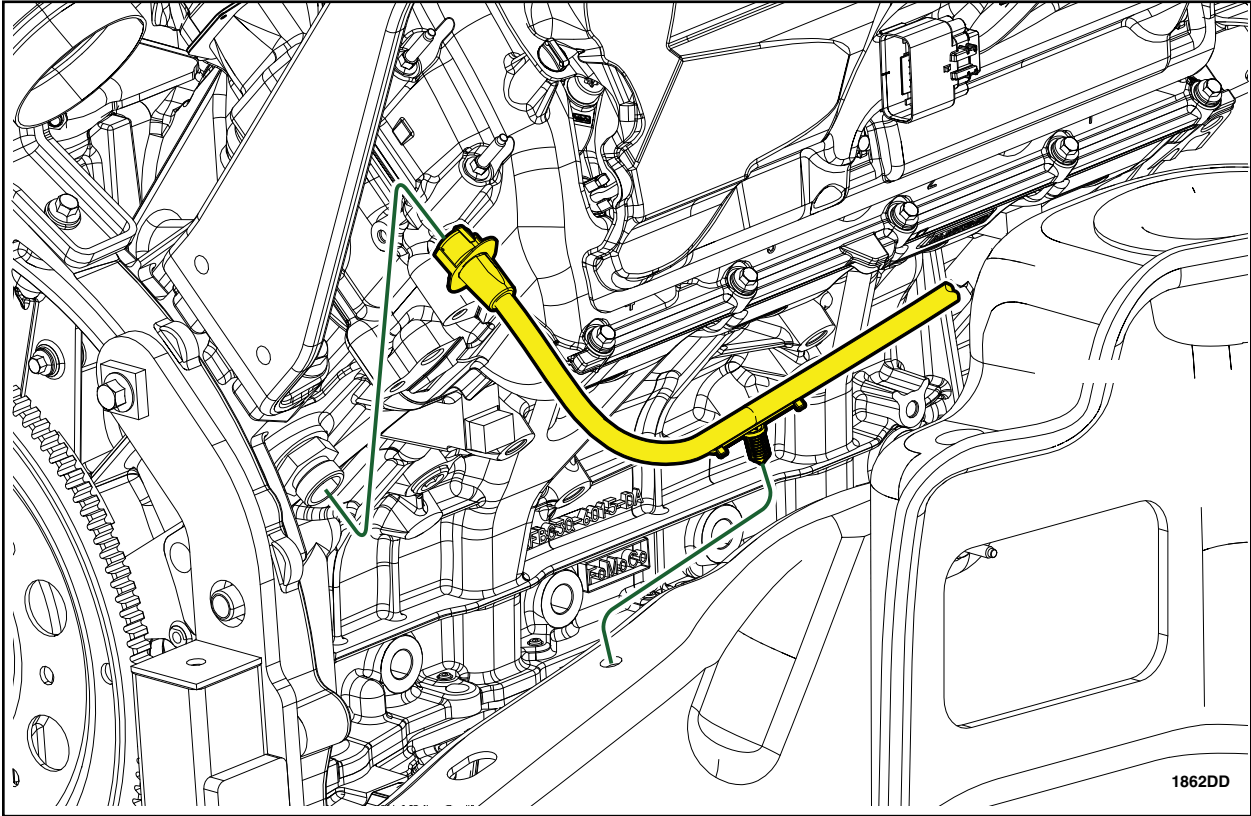

FIGURE 4a

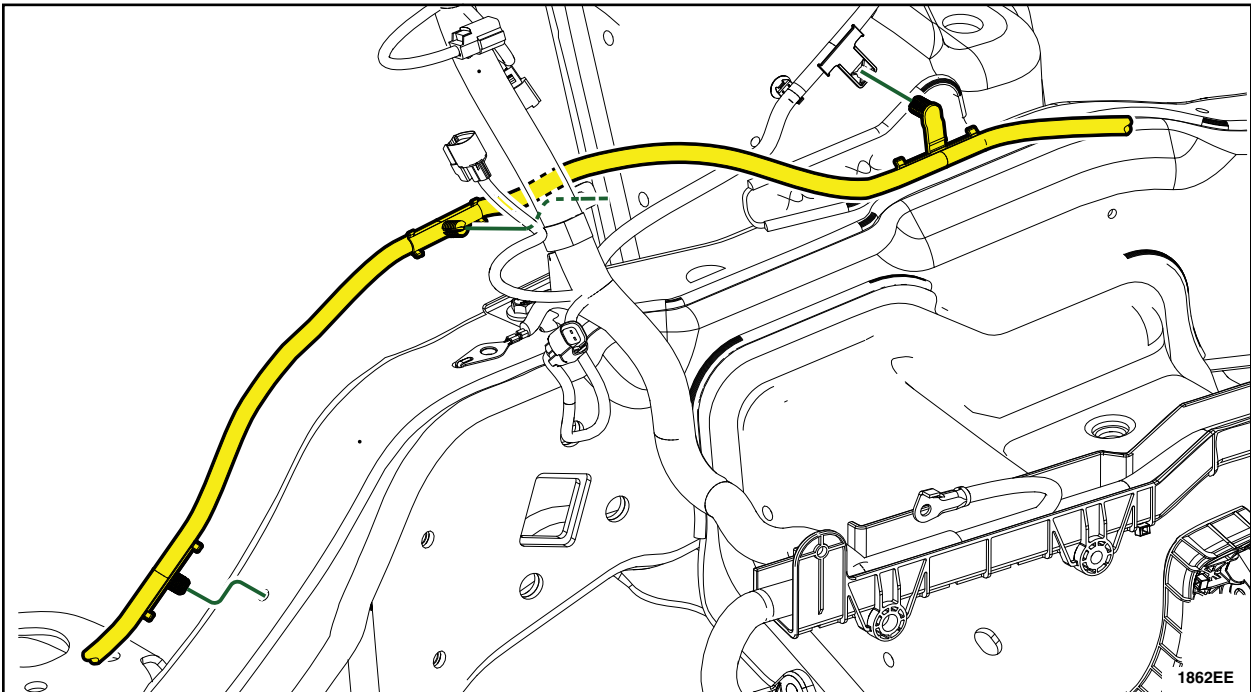
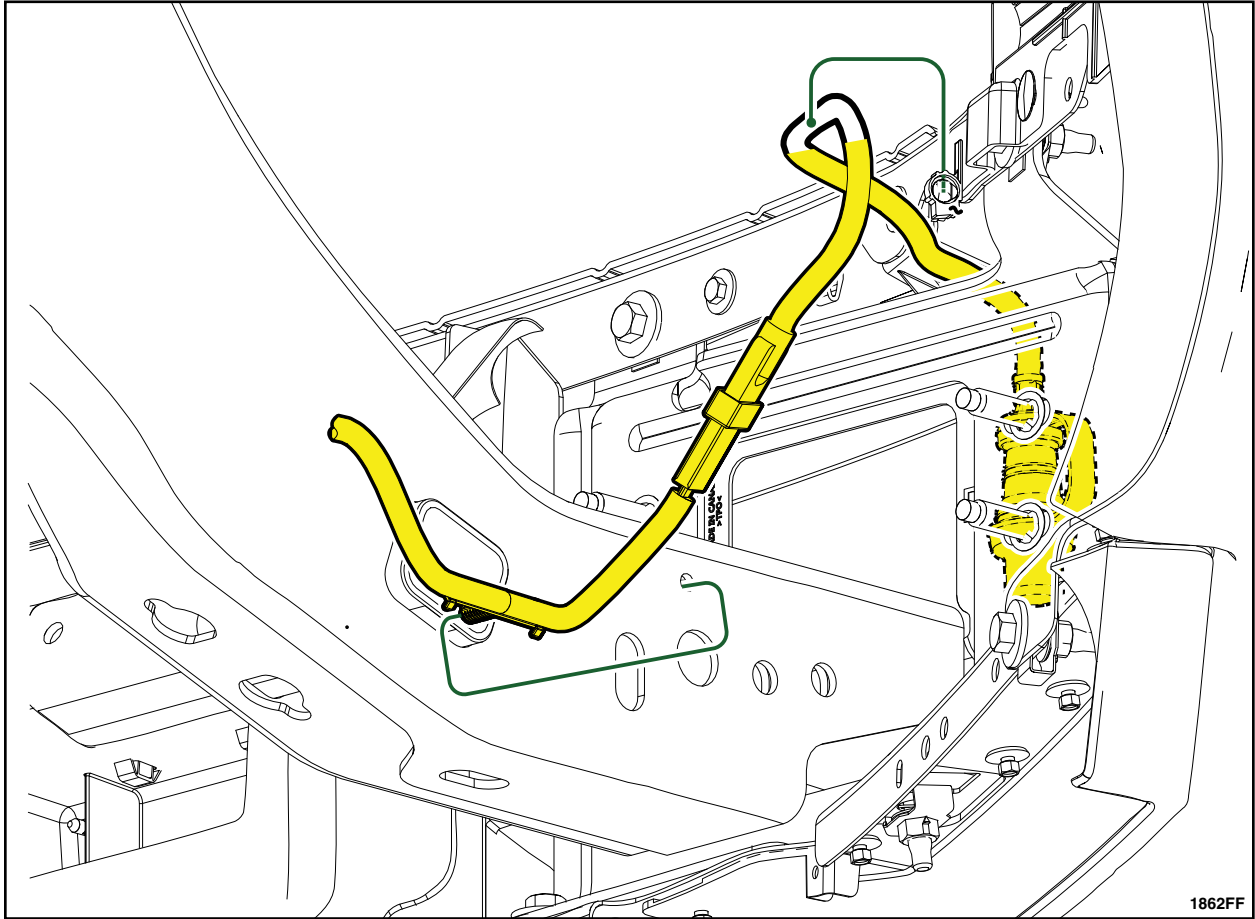

FIGURE 4b





1862FF

FIGURE 4c



Vehicles Equipped with 6.8L Engines

1. Disconnect the block heater electrical connector. See Figure 5.

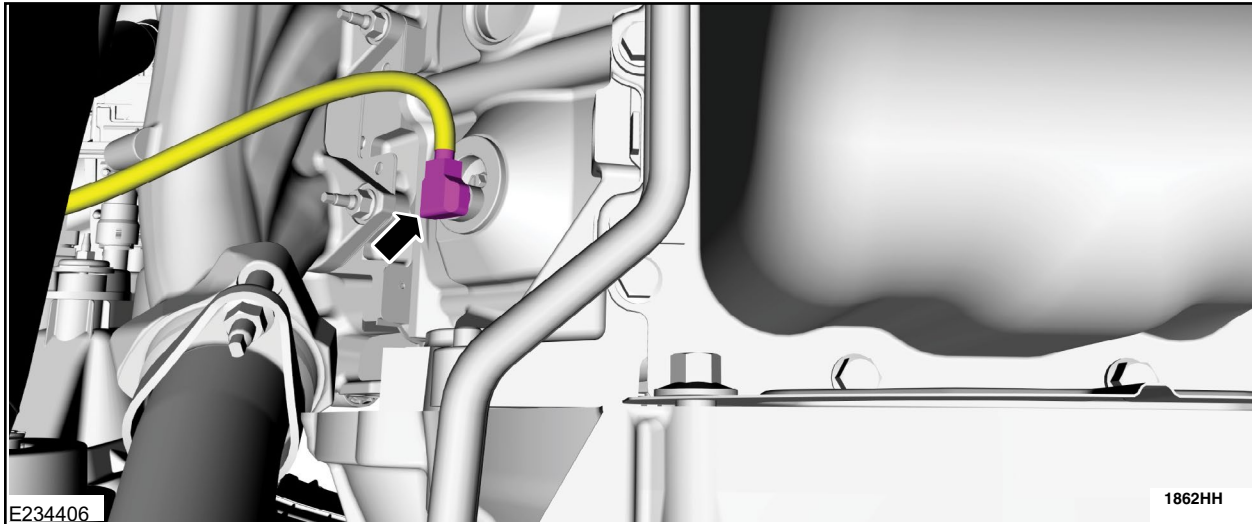
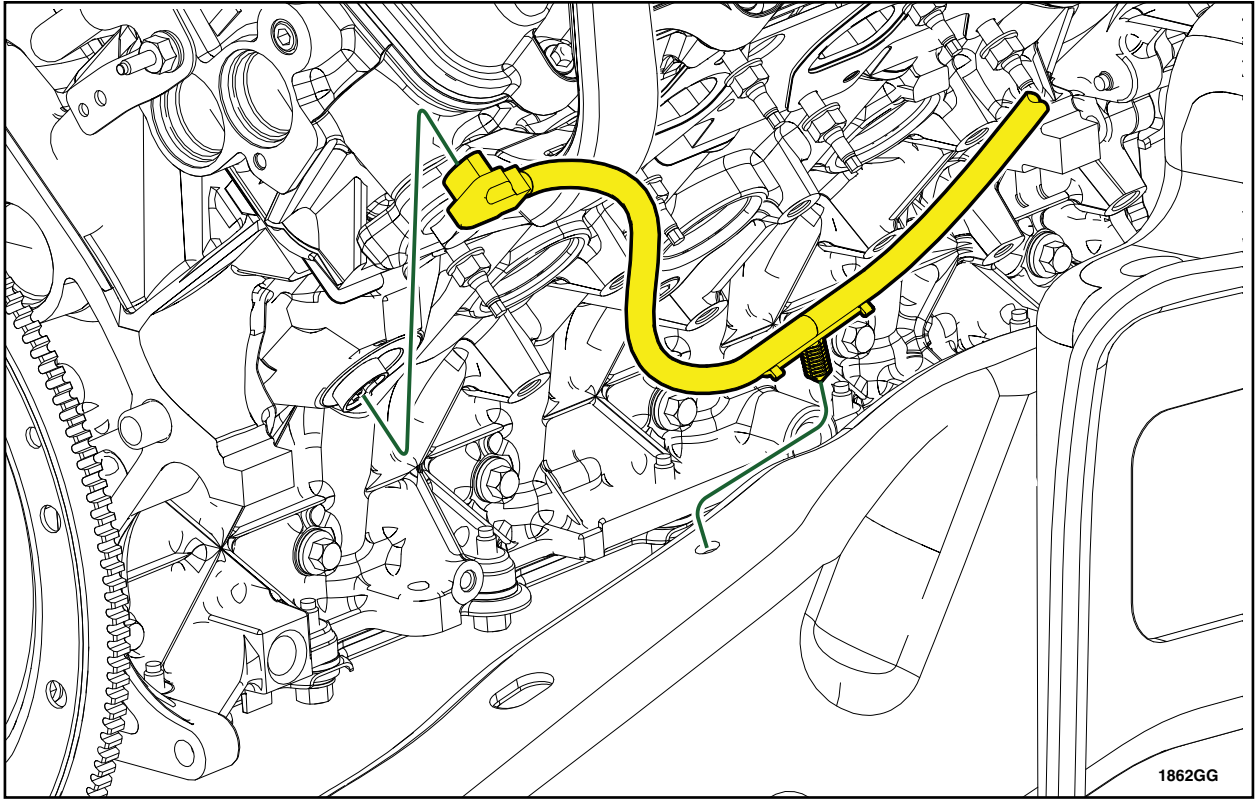

FIGURE 5

2. Remove and discard the wire assembly. See Figures 6a, 6a and 6c.
3. Apply XG-12 Motorcraft® Electrical Grease or equivalent to the *new* wire assembly in-line connector pins, on both sides of the wire assembly connector.
4. Connect the wire assembly in-line connector. See Figure 6c.
5. Install the *new* wire assembly in the vehicle following the same routing as the wire assembly that is being replaced. See Figures 6a, 6b and 6c.
6. Connect the *new* wire assembly to the block heater element. See Figure 5.





1862GG

FIGURE 6a



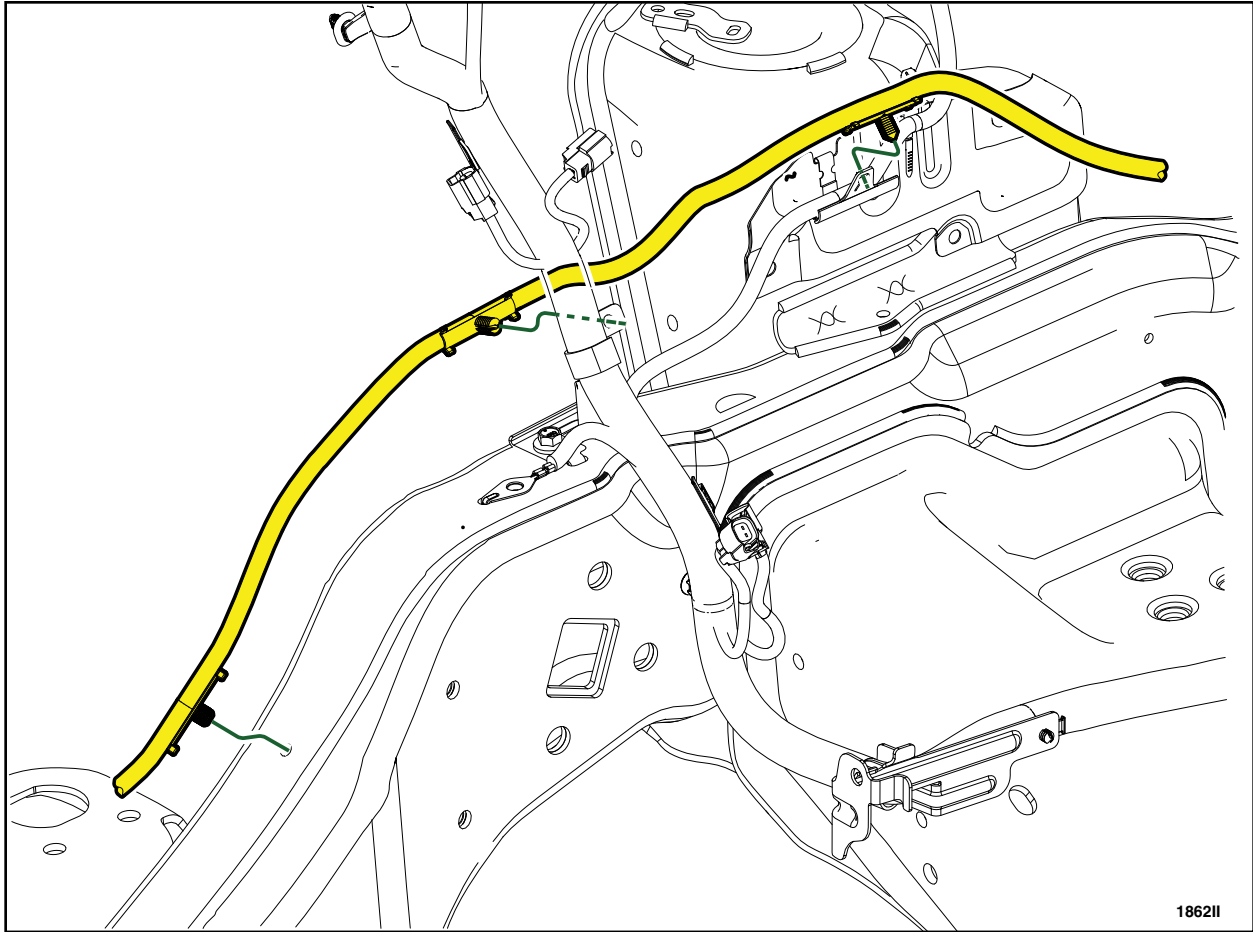
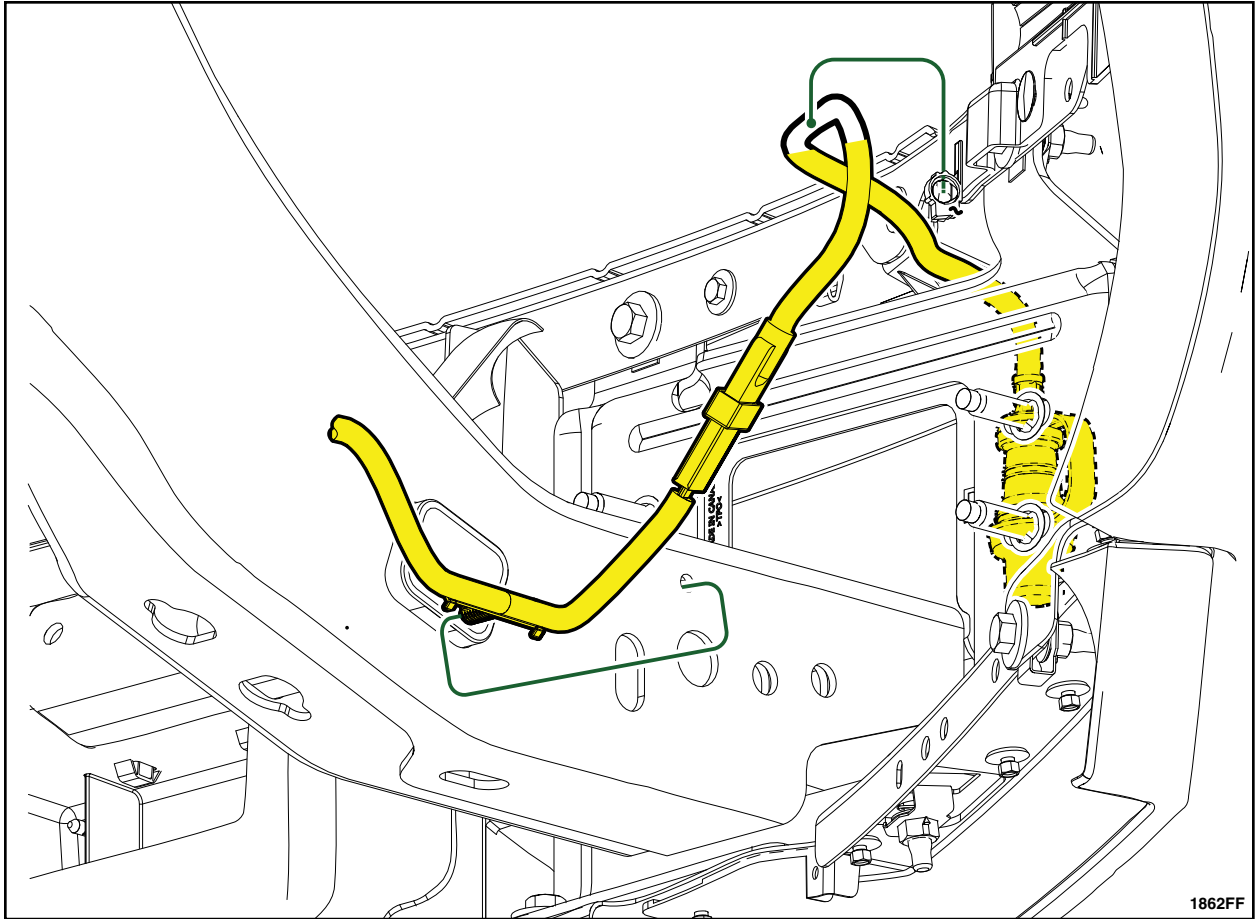

FIGURE 6b





1862FF

FIGURE 6c



Did Not Pass Engine Block Heater Corrosion Inspection Customer Information Sheet

Ford Motor Company is voluntarily recalling certain 2015 - 2019 Model Year F-150 and 2017 – 2019 Model Year F-Super Duty vehicles equipped With Engine Block Heaters. Your dealer has completed an inspection of the wire assembly connector and has found that your engine block heater wire assembly requires replacement.

Parts for the permanent repair of your vehicle are not currently available. We apologize for any inconvenience this part shortage may cause you. When parts become available, Ford Motor Company will notify you via mail to schedule a service appointment with your dealer for repairs to be completed free of charge (parts and labor). Parts are anticipated to be available 1st Quarter, 2019.

DO NOT USE THE ENGINE BLOCK HEATER IN YOUR VEHICLE DUE TO THE RISK OF AN ENGINE COMPARTMENT FIRE AND/OR PROPERTY DAMAGE.

If the engine block heater continues to be used, ensure vehicle is parked outside and away from any structures, connect the system to a ground-fault circuit interrupter (GFCI) 120-volt AC electrical outlet and follow all instructions and warnings below, which are in your vehicles owner's manual.

- Failure to follow engine block heater instructions could result in property damage or serious personal injury
- Do not use your heater with ungrounded electrical systems or two-pronged adapters. There is a risk of electrical shock.
- Make sure your vehicle is parked in a clean area, clear of combustibles.
- Use a 16-gauge outdoor extension cord that is product certified by Underwriter's Laboratory (UL) or Canadian Standards Association (CSA). This extension cord must be suitable for use outdoors, in cold temperatures, and be clearly marked Suitable for Use with Outdoor Appliances. Do not use an indoor extension cord outdoors. This could result in an electric shock or become a fire hazard.
- Use as short an extension cord as possible.
- Do not use multiple extension cords.
- Make sure that when in operation, the extension cord plug and heater cord plug connections are free and clear of water. This could cause an electric shock or fire.
- Make sure the heater, heater cord, and extension cord are firmly connected.
- Check for heat anywhere in the electrical hookup once the system has been operating for approximately 30 minutes.
- Make sure the system is unplugged and properly stowed before starting and driving your vehicle. Make sure the protective cover seals the prongs of the block heater cord plug when not in use.

Ford has not issued instructions to stop driving your vehicle under this safety recall. Owners can continue to safely drive their vehicle if they follow all instructions and warnings. Again, we apologize for the inconvenience this situation causes and assure you that we are doing everything possible to expedite resolution.

Sincerely,

Ford Motor Company
Ford Customer Service Division

Ford Motor Company
Recall Reimbursement Plan for 18S45

Ford and Lincoln dealers are in the best position to quickly and efficiently process reimbursement requests. However, federal legislation requires all motor vehicle manufacturers to establish processes through which customers may seek recall reimbursement directly from the manufacturer or from the dealers.

Regarding the specific reimbursement plan for Recall # 18S45, owners who have paid for service to remedy the defect or noncompliance must have had that service performed prior to January 28, 2019. After this date, if repairs related to this recall are performed by a non-Ford repair facility in an emergency situation, customers must submit any refund requests through their dealership. As required by this federal regulation, Ford Motor Company submitted the details of its latest General Recall Reimbursement Plan in a letter to the National Highway Traffic Safety Administration (NHTSA) in February 2015. The following is the text of that letter and the Plan:

General Recall Reimbursement Plan
(As submitted to the NHTSA)

Pursuant to the requirements set forth in 49 CFR Part 573 and Part 577 of the Code of Federal Regulations, Ford Motor Company (Ford) is submitting required information pertaining to our general reimbursement plan for the cost of remedies paid for by vehicle owners before they are notified of a related safety recall.

Set forth below is Ford's general plan to reimburse owners and purchasers for costs incurred for remedies in advance of notification of potential safety-related defects or noncompliances pursuant to Part 573.6 (c)(8)(i). This plan has not changed since our February 20, 2015 submission.

Reimbursement Notification

Ford's notice to a vehicle owner in accordance with 49 CFR Part 577 will indicate that Ford is offering a refund if the owner paid to have service to remedy the defect or noncompliance prior to a specified ending date. In accordance with Part 573.13 (c)(2), this ending date will be defined as a minimum of ten calendar days after the date on which Ford mailed the last of its Part 577 notifications to owners, and will be indicated in the specific reimbursement plan available to owners for an individual recall. This notice will direct owners to seek eligible reimbursement through authorized dealers or, at their option, directly through Ford at the following address:

Ford Motor Company
P.O. Box 6251
Dearborn, MI 48121-6251

Ford notes that this rule allows for the identification of a beginning date for reimbursement eligibility. Under the rule, an owner who paid to remedy the defect or noncompliance prior to the identified beginning date would not be eligible for reimbursement. Ford generally has not established such a beginning date for reimbursement eligibility and does not presently anticipate changing this general policy. However, in any case where Ford determines a beginning date is appropriate, Ford will indicate that date in the owner notice. As permitted by 577.11(e), Ford may not include a reimbursement notification when all vehicles are well within the warranty period, subject to approval by the agency.

Costs to be Reimbursed

For vehicles, reimbursement will not be less than the lesser of:

- The amount paid by the owner for the remedy that specifically addressed and was reasonably necessary to correct the defect or noncompliance that is the subject of the recall, or
- The cost of parts for the remedy (to be no more than the manufacturer's list retail price for authorized part(s), plus associated labor at local labor rates, miscellaneous fees (such as disposal of waste) and taxes.

For replacement equipment, reimbursement will be the amount paid by the owner for the replacement item (limited by the amount of the retail list price of the defective or noncompliant item that was replaced, plus taxes, where the brand or model purchased by the owner was different than the brand or model that was the subject of the recall). If the item of motor vehicle equipment was repaired, the reimbursement provisions identified above for vehicles will apply.

Ford notes that costs incurred by the owner within the period during which Ford's original or extended warranty would have provided for a free repair of the problem will not be eligible for reimbursement, as provided by Part 573.13 (d)(1).

Entities Authorized to Provide Reimbursement

Ford will continue to use authorized dealers to reimburse owners under the specific reimbursement plans for a particular recall, and will encourage owners to pursue requests for reimbursement directly through dealers to expedite reimbursement. Ford will also provide a mailing address to which customers can, at their option, send requests for reimbursement directly to Ford, as previously noted. Requests for reimbursement sent directly to Ford may take up to 60 days to process. Whether the owner chooses to pursue reimbursement requests through a dealer or directly through Ford, the owner will be directed to submit the required documentation, upon which reimbursement eligibility will be determined.

Required Documentation

The reimbursement determination will depend upon the information provided by the customer. Consistent with Part 573.13 (d)(4) the following information must be submitted:

- Claimant name and address
- Vehicle make, model, and model year
- Vehicle identification number (VIN) and, for replacement equipment, a description of such equipment or, for tires, the model, size and TIN (DOT code)
- Identification of the recall number (either the Ford recall number or the NHTSA recall number)
- Identification of the owner of the recalled vehicle at the time that the pre-notification remedy was obtained
- An original receipt for the pre-notification remedy that includes a breakdown of the amount for parts, labor, other costs and taxes, including costs for the replacement item. Where the receipt covers work other than to address the recall or noncompliance, Ford may require the claimant to separately identify costs that are eligible for reimbursement.
- If the remedy was obtained during the warranty period, documentation indicating that the warranty was not honored or the warranty repair did not correct the problem related to the recall.

Failure to submit all of the above information may result in denial of the reimbursement request.

Additional Information

The Part 577 required owner notice will provide a toll-free telephone number through which specific information about the reimbursement plan can be requested from Ford. This general reimbursement plan will be incorporated into notifications pursuant to Part 573.6 by reference. Information specific to an individual recall also may be incorporated into the Part 573.6 notification.