



David J. Johnson  
 Director  
 Service Engineering Operations  
 Ford Customer Service Division

Ford Motor Company  
 P. O. Box 1904  
 Dearborn, Michigan 48121

November 15, 2018

**TO:** All U.S. Ford and Lincoln Dealers

**SUBJECT: NEW VEHICLE DEMONSTRATION / DELIVERY HOLD - Safety Recall 18S35**  
 Certain 2018 Model Year Explorer Vehicles Equipped with GTDI Engines  
 Fuel Tank Jumper Tube Replacement

**AFFECTED VEHICLES**

Vehicle	Model Year	Assembly Plant	Build Dates
Explorer with GTDI Engines	2018	Chicago	July 29, 2018 through July 31, 2018

Affected vehicles are identified in OASIS and FSA VIN Lists.

**REASON FOR THIS SAFETY RECALL**

In some of the affected vehicles, it is possible that the fuel line pressure sensor may not have been assembled correctly into the fuel tank jumper tube, which can result in a fuel leak. A fuel leak in the presence of an ignition source increases the risk of a fire.

**SERVICE ACTION**

Before demonstrating or delivering any new in-stock vehicles involved in this recall, dealers are to replace the fuel tank jumper tube, which includes the fuel pressure sensor. This service must be performed on all affected vehicles at no charge to the vehicle owner.

**OWNER NOTIFICATION MAILING SCHEDULE**

Owner letters are expected to be mailed the week of December 3, 2018. Dealers should repair any affected vehicles that arrive at their dealerships, whether or not the customer has received a letter.

**PLEASE NOTE:**

**Federal law requires dealers to complete this recall service before a new vehicle is delivered to the buyer or lessee. Violation of this requirement by a dealer could result in a civil penalty of up to \$21,000 per vehicle. Correct all vehicles in your new vehicle inventory before delivery.**

**ATTACHMENTS**

- Attachment I: Administrative Information
- Attachment II: Labor Allowances and Parts Ordering Information
- Attachment III: Technical Information
- Owner Notification Letters

**QUESTIONS & ASSISTANCE**

For questions and assistance, contact the Special Service Support Center (SSSC) via the SSSC Web Contact Site. The SSSC Web Contact Site can be accessed through the Professional Technician Society (PTS) website using the SSSC link listed at the bottom of the OASIS VIN report screen or listed under the SSSC tab.

Sincerely,

David J. Johnson

**NEW VEHICLE DEMONSTRATION / DELIVERY HOLD - Safety Recall 18S35**  
Certain 2018 Model Year Explorer Vehicles Equipped with GTDI Engines  
Fuel Tank Jumper Tube Replacement

**OASIS ACTIVATION**

OASIS will be activated on November 15, 2018.

**FSA VIN LISTS ACTIVATION**

FSA VIN Lists will be available through <https://web.fsavinlists.dealerconnection.com> on November 15, 2018. Owner names and addresses will be available by December 21, 2018.

**NOTE:** Your FSA VIN Lists may contain owner names and addresses obtained from motor vehicle registration records. The use of such motor vehicle registration data for any purpose other than in connection with this recall is a violation of law in several states, provinces, and countries. Accordingly, you must limit the use of this listing to the follow-up necessary to complete this recall.

**SOLD VEHICLES**

- Ford has not issued instructions to stop selling/delivering or driving used vehicles under this safety recall. Owners should contact their dealer for an appointment to have their vehicles remedied as soon as practicable.
- Owners of affected vehicles will be directed to dealers for repairs.
- Immediately contact any of your affected customers whose vehicles are not on your VIN list but are identified in OASIS. Give the customer a copy of the Owner Notification Letter (when available) and schedule a service date.
- Correct other affected vehicles identified in OASIS which are brought to your dealership.
- Dealers are to prioritize repairs of customer vehicles over repairs of new and used vehicle inventory.

**STOCK VEHICLES**

- Correct all affected units in your new vehicle inventory before delivery.
- Use OASIS to identify any affected vehicles in your used vehicle inventory.

**DEALER-OPERATED RENTAL VEHICLES**

The Fixing America's Surface Transportation (FAST) Act law effective June 2016 prohibits a rental company from selling, renting or leasing vehicles subject to a safety or compliance recall. Please consult your legal counsel for legal advice.

**TITLE BRANDED / SALVAGED VEHICLES**

Affected title branded and salvaged vehicles are eligible for this recall.

**OWNER REFUNDS**

Refunds are not approved for this program.

**RENTAL VEHICLES**

Rental vehicles are not approved for this program.

**NEW VEHICLE DEMONSTRATION / DELIVERY HOLD - Safety Recall 18S35**  
Certain 2018 Model Year Explorer Vehicles Equipped with GTDI Engines  
Fuel Tank Jumper Tube Replacement

**ADDITIONAL REPAIR (LABOR TIME AND/OR PARTS)**

Additional repairs identified as necessary to complete the FSA should be managed as follows:

- For related damage and access time requirements, refer to the Warranty and Policy Manual / Section 6 – Ford & Lincoln Program Policies / General Information & Special Circumstances for FSA's / Related Damage.
- For vehicles within new vehicle bumper-to-bumper warranty coverage, no SSSC approval is required, although related damage must be on a separate repair line with the "Related Damage" radio button checked.
  - Ford vehicles – 3 years or 36,000 miles
- For vehicles outside new vehicle bumper-to-bumper warranty coverage, submit an Approval Request to the SSSC Web Contact Site prior to completing the repair.

**CLAIMS PREPARATION AND SUBMISSION**

- **Claim Entry:** Enter claims using Dealer Management System (DMS) or One Warranty Solution (OWS) online.
  - When entering claims, select claim type 31: Field Service Action. The FSA number (18S35) is the sub code.
  - For additional claims preparation and submission information, refer to the Recall and Customer Satisfaction Program (CSP) Repairs in the OWS User Guide.
- **Related Damage/Additional labor and/or parts:** Must be claimed as Related Damage on a separate repair line from the FSA with same claim type and sub code as described in Claim Entry above.

**IMPORTANT:** Click the Related Damage Indicator radio button.

**NEW VEHICLE DEMONSTRATION / DELIVERY HOLD - Safety Recall 18S35**

Certain 2018 Model Year Explorer Vehicles Equipped with GTDI Engines

Fuel Tank Jumper Tube Replacement

**LABOR ALLOWANCES**

Description	Labor Operation	Labor Time
Replace fuel tank jumper tube	18S35B	0.7 Hours

**PARTS REQUIREMENTS / ORDERING INFORMATION****SSSC Web Contact Site:**

To place an order for a fuel tank jumper tube, submit a VIN-specific Part Order contact via the SSSC Web Contact Site.

Part Number	Description	Order Quantity	Claim Quantity
DA8Z-9S278-A	Fuel tank jumper tube	1	1
N811781-S439	Fuel tank strap bolt	1	1

Dealers will be notified via a DOES II communication if circumstances warrant a change in part supply strategy and when open ordering resumes.

**DEALER PRICE**

For latest prices, refer to DOES II.

**PARTS RETENTION AND RETURN**

Follow the provisions of the Warranty and Policy Manual, Section 1 - WARRANTY PARTS RETENTION AND RETURN POLICIES.

**EXCESS STOCK RETURN**

Excess stock returned for credit must have been purchased from Ford Customer Service Division in accordance with Policy Procedure Bulletin 4000.

## CERTAIN 2018 MODEL YEAR EXPLORER VEHICLES EQUIPPED WITH GTDI ENGINES – FUEL TANK JUMPER TUBE REPLACEMENT

### OVERVIEW

In some of the affected vehicles, it is possible that the fuel line pressure sensor may not have been assembled correctly into the fuel tank jumper tube, which can result in a fuel leak. Before demonstrating or delivering any new in-stock vehicles involved in this recall, dealers are to replace the fuel tank jumper tube, which includes the fuel pressure sensor. This service must be performed on all affected vehicles at no charge to the vehicle owner.

### SERVICE PROCEDURE

#### Recommended Tool List For Replacement:

General Tools	Special Tool
Ratchet - 1/4", 3/8"	Fuel line disconnect tool 310-250
1/4" Drive deep socket - 10mm	
Power tool - 1/4", 3/8"	
3/8" Drive standard length socket - 10mm, 15mm	
Torque wrench - 1/4", 3/8"	
Fuse puller	



**WARNING:** Before beginning any service procedure in this section, refer to Safety Warnings in Section 100-00 General Information. Failure to follow this instruction may result in serious personal injury.

1. Position the vehicle on a hoist. Please follow the Workshop Manual (WSM) procedures in Section 100-02.

**NOTE:** Release the fuel system pressure by performing the following steps.

2. Open the hood and remove the battery junction box cover.



3. Remove the 30 amp, F63 Fuel Pump relay fuse. See Figure 1.

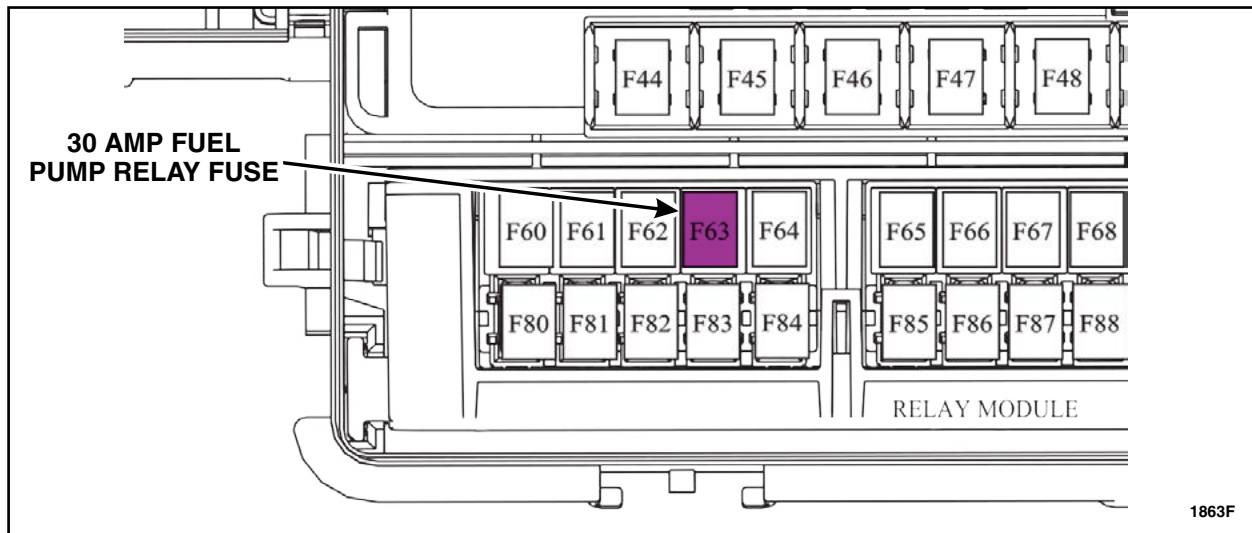
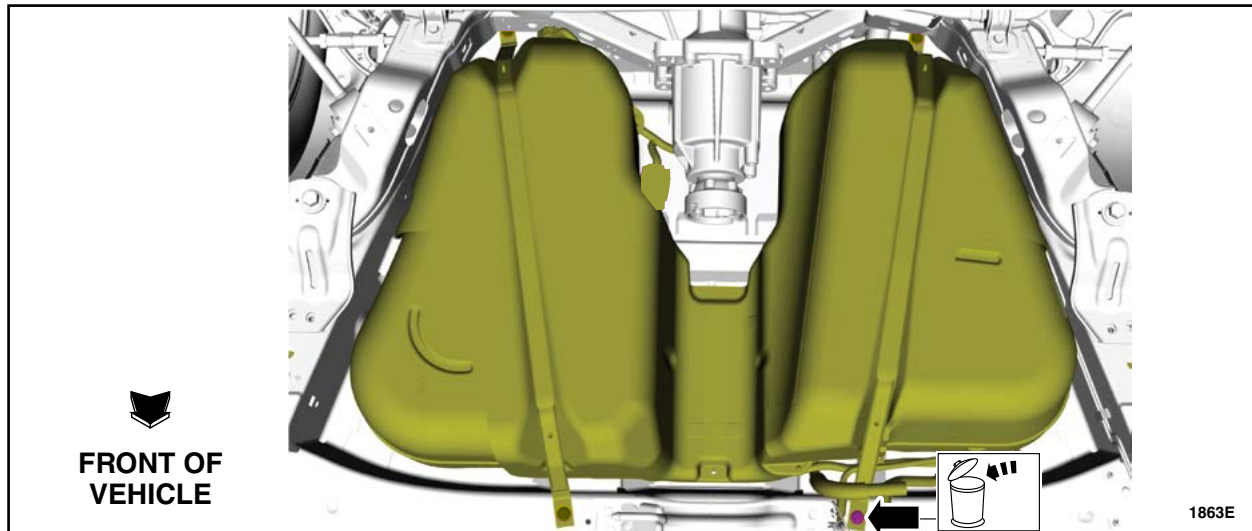

**FIGURE 1**

4. Start the engine and allow it to idle until it stalls.
5. After the engine stalls, crank the engine for approximately 5 seconds to make sure the fuel rail pressure has been released.
6. Turn the ignition switch to the OFF position.
7. Disconnect the battery ground cable. Please follow the WSM procedures in Section 414-01.
8. Remove the Evaporative Emission Canister.
  - For 2.3L EcoBoost engine, please follow the WSM procedures in Section 303-13A.
  - For 3.5L EcoBoost engine, please follow the WSM procedures in Section 303-13B.
9. Support the right side of the fuel tank using suitable jack stand.



10. Remove and discard the right front fuel tank strap bolt only and lower the right front section of the fuel tank enough to service the fuel tank jumper tube. See Figure 2.



**FIGURE 2**

11. Remove the retaining clip and disconnect the fuel tank jumper tube spring lock coupling (Special tool 310-250). See Figures 3.

- For 2.3L EcoBoost engine, please follow the WSM procedures in Section 310-00A.
- For 3.5L EcoBoost engine, please follow the WSM procedures in Section 310-00B.

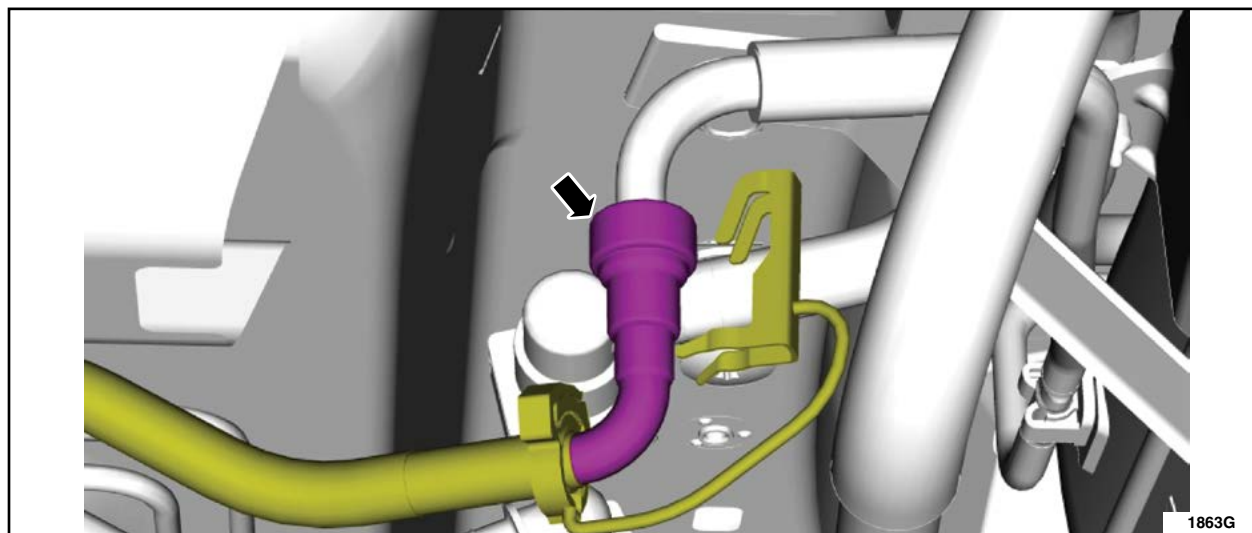
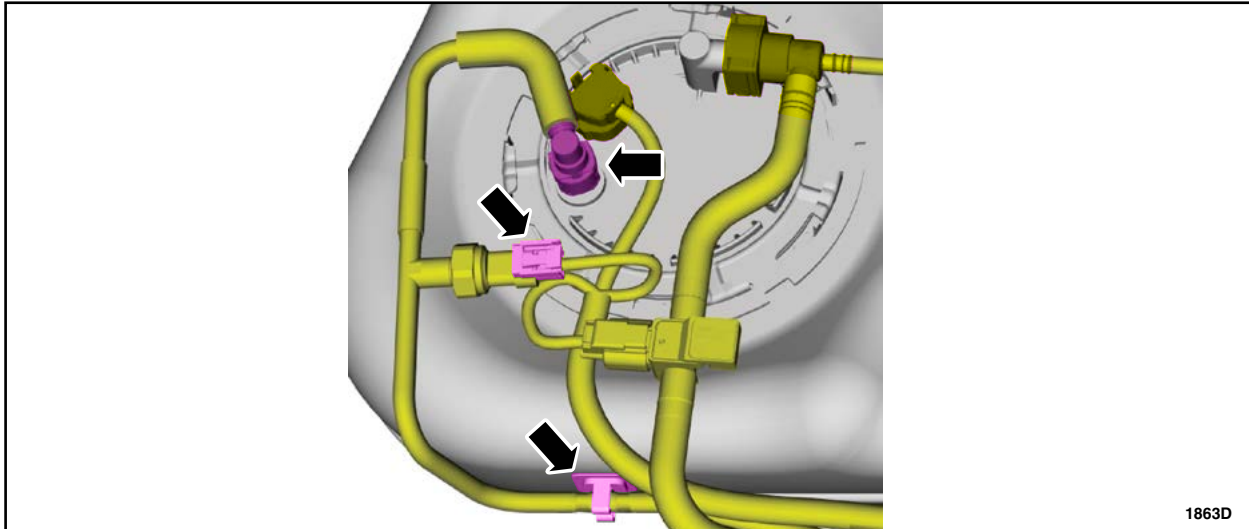

**FIGURE 3**



12. Disconnect the fuel tank clip, quick release coupling and fuel pressure sensor electrical connector. Remove and discard the fuel tank jumper tube. See Figure 4.

- For 2.3L EcoBoost engine, please follow the WSM procedures in Section 310-00A.
- For 3.5L EcoBoost engine, please follow the WSM procedures in Section 310-00B.



**FIGURE 4**

13. Install a *new* fuel tank jumper tube. See Figures 3 and 4.

14. Lift the tank and install a new right front tank strap bolt.

- Torque: 26 lb. ft. (35 Nm).

15. Install the evaporative emission canister.

- For 2.3L EcoBoost engine, please follow WSM procedures in Section 303-13A.
- For 3.5L EcoBoost engine, please follow WSM procedures in Section 303-13B.

16. Connect the battery ground cable. Please follow the WSM procedures in Section 414-01.

17. Install the 30 amp, F63 Fuel Pump relay fuse. See Figure 1.

18. Check for leaks before starting the engine by cycling the ignition on for 3 seconds to pressurize the fuel system.

19. Start the engine and check for leaks.

20. Using Integrated Diagnostic System (IDS) clear any Diagnostic Trouble Codes (DTCs).

