



David J. Johnson
 Director
 Service Engineering Operations
 Ford Customer Service Division

Ford Motor Company
 P. O. Box 1904
 Dearborn, Michigan 48121

December 20, 2018

TO: All U.S. Ford and Lincoln Dealers

**SUBJECT: NEW VEHICLE DEMONSTRATION / DELIVERY HOLD -
 Safety Recall 18S37 - Supplement #1**

Certain 2018 Model Year Expedition and Navigator Vehicles with 40/20/40 Second Row Seating
 Second Row Center Seat Frame Inspection

REF: NEW VEHICLE DEMONSTRATION / DELIVERY HOLD - Safety Recall 18S37
 Dated November 15, 2018

New! REASON FOR THIS SUPPLEMENT

- **Service Action:** Parts are now available, in limited supply, for repairs to customer-owned vehicles in extenuating circumstances and unsold vehicles with a signed sales contract.
- **Parts Requirements / Ordering Information:** Part orders will be placed by the SSSC. Part Order contacts should include images of the seat frame showing missing J-channel bracket(s) and the VIN tag.
- **Labor Allowance:** Labor operation for seat frame replacement has been added.

AFFECTED VEHICLES

Vehicle	Model Year	Assembly Plant	Build Dates
Expedition	2018	Kentucky Truck	March 14, 2017 through August 18, 2018
Navigator			March 31, 2017 through August 18, 2018

Affected vehicles are identified in OASIS and FSA VIN Lists.

REASON FOR THIS SAFETY RECALL

In some of the affected vehicles, the second row center seat frame may not have been assembled with one or both of the J-channel brackets in the seat track. A second row center seat frame assembled without a J-channel bracket, and is adjusted at or near the full forward position, may not restrain an occupant properly in the event of a crash.

New! SERVICE ACTION

Before demonstrating or delivering any new in-stock vehicles involved in this recall, dealers are to inspect the second row center seat frame track to ensure both J-channel brackets are present. If one or both brackets are missing, dealers will replace the seat frame assembly. This service must be performed on all affected vehicles at no charge to the vehicle owner.

At this time, parts are not available to repair all vehicles; however, less than 2% of the affected vehicle population is expected to require seat frame replacement. Until parts are available to repair all vehicles, dealers may submit an approval request to the SSSC to authorize repairs on customer-owned vehicles in extenuating circumstances and unsold vehicles with a signed sales contact.

New! SERVICE ACTION, Continued

Parts to repair all vehicles are expected to be available in the first quarter 2019, at which time this bulletin will be supplemented.

OWNER NOTIFICATION MAILING SCHEDULE

Owner letters are expected to be mailed the week of December 17, 2018. Dealers should inspect any affected vehicles that arrive at their dealerships, whether or not the customer has received a letter. Until the vehicle is serviced for this concern, passengers should adjust the second row center seat to its full rearward position.

PLEASE NOTE:

Federal law requires dealers to complete this recall service before a new vehicle is delivered to the buyer or lessee. Violation of this requirement by a dealer could result in a civil penalty of up to \$21,000 per vehicle. Correct all vehicles in your new vehicle inventory before delivery.

ATTACHMENTS

Attachment I: Administrative Information
Attachment II: Labor Allowances and Parts Ordering Information
Attachment III: Technical Information
Owner Notification Letters

QUESTIONS & ASSISTANCE

For questions and assistance, contact the Special Service Support Center (SSSC) via the SSSC Web Contact Site. The SSSC Web Contact Site can be accessed through the Professional Technician Society (PTS) website using the SSSC link listed at the bottom of the OASIS VIN report screen or listed under the SSSC tab.

Sincerely,



David J. Johnson

NEW VEHICLE DEMONSTRATION / DELIVERY HOLD -**Safety Recall 18S37 - Supplement #1**

Certain 2018 Model Year Expedition and Navigator Vehicles with 40/20/40 Second Row Seating
Second Row Center Seat Frame Inspection

OASIS ACTIVATION

OASIS was activated on November 15, 2018.

New! FSA VIN LISTS ACTIVATION

FSA VIN Lists was available through <https://web.fsavinlists.dealerconnection.com> on November 15, 2018. *Owner names and addresses will be available once parts are available to repair all vehicles.*

NOTE: Your FSA VIN Lists may contain owner names and addresses obtained from motor vehicle registration records. The use of such motor vehicle registration data for any purpose other than in connection with this recall is a violation of law in several states, provinces, and countries. Accordingly, you must limit the use of this listing to the follow-up necessary to complete this recall.

SOLD VEHICLES

- Ford has not issued instructions to stop selling/delivering or driving used vehicles under this safety recall. Owners should contact their dealer for an appointment to have their vehicles remedied as soon as practicable. Owners can continue to safely drive their vehicles if they follow all instructions and warnings contained in the recall notice.
- Owners of affected vehicles will be directed to dealers for repairs.
- When parts are available to repair all vehicles, immediately contact any of your affected customers whose vehicles are not on your VIN list but are identified in OASIS. Give the customer a copy of the Owner Notification Letter (when available) and schedule a service date.
- Correct other affected vehicles identified in OASIS which are brought to your dealership.
- Dealers are to prioritize repairs of customer vehicles over repairs of new and used vehicle inventory.

STOCK VEHICLES

- Correct all affected units in your new vehicle inventory before delivery.
- Use OASIS to identify any affected vehicles in your used vehicle inventory.

DEALER-OPERATED RENTAL VEHICLES

The Fixing America's Surface Transportation (FAST) Act law effective June 2016 prohibits a rental company from selling, renting or leasing vehicles subject to a safety or compliance recall. Please consult your legal counsel for legal advice.

TITLE BRANDED / SALVAGED VEHICLES

Affected title branded and salvaged vehicles are eligible for this recall.

New! RENTAL VEHICLES

For sold customer vehicles in extenuating circumstance that do not pass the seat frame inspection, please contact the SSSC via the SSSC Web Contact Site if a rental vehicle is needed.

NEW VEHICLE DEMONSTRATION / DELIVERY HOLD -**Safety Recall 18S37 - Supplement #1**

Certain 2018 Model Year Expedition and Navigator Vehicles with 40/20/40 Second Row Seating
Second Row Center Seat Frame Inspection

ADDITIONAL REPAIR (LABOR TIME AND/OR PARTS)

Additional repairs identified as necessary to complete the FSA should be managed as follows:

- For related damage and access time requirements, refer to the Warranty and Policy Manual / Section 6 – Ford & Lincoln Program Policies / General Information & Special Circumstances for FSA's / Related Damage.
- For vehicles within new vehicle bumper-to-bumper warranty coverage, no SSSC approval is required, although related damage must be on a separate repair line with the "Related Damage" radio button checked.
 - Ford vehicles – 3 years or 36,000 miles
 - Lincoln vehicles – 4 years or 50,000 miles
- For vehicles outside new vehicle bumper-to-bumper warranty coverage, submit an Approval Request to the SSSC Web Contact Site prior to completing the repair.

CLAIMS PREPARATION AND SUBMISSION

- **Claim Entry:** Enter claims using Dealer Management System (DMS) or One Warranty Solution (OWS) online.
 - When entering claims, select claim type 31: Field Service Action. The FSA number 18S37 is the sub code.
 - For additional claims preparation and submission information, refer to the Recall and Customer Satisfaction Program (CSP) Repairs in the OWS User Guide.
- **Related Damage/Additional labor and/or parts:** Must be claimed as Related Damage on a separate repair line from the FSA with same claim type and sub code as described in Claim Entry above.

IMPORTANT: Click the Related Damage Indicator radio button.

NEW VEHICLE DEMONSTRATION / DELIVERY HOLD -**Safety Recall 18S37 - Supplement #1**

Certain 2018 Model Year Expedition and Navigator Vehicles with 40/20/40 Second Row Seating
Second Row Center Seat Frame Inspection

New! LABOR ALLOWANCES

Description	Labor Operation	Labor Time
Inspect second row center seat; Pass (both J-channel brackets present). Recall will be closed.	18S37A	0.2 Hours
Inspect second row center seat; Does Not Pass (one or both J-channel brackets not present, seat frame replacement required). <i>Recall will remain open until parts are available to repair all vehicles.</i>	18S37B	0.2 Hours
<i>Replace seat frame assembly (Customer-owned vehicles in extenuating circumstances and unsold vehicles with a signed sales contract only).</i>	18S37C	2.2 Hours

Less than 2% of the affected vehicle population is expected to require seat frame replacement.

New! PARTS REQUIREMENTS / ORDERING INFORMATION

Parts are not yet available to repair all vehicles assembled with seat frames missing the J-channel brackets. *Additional information to support this safety recall will be published to dealers as a supplement in the first quarter 2019. Until parts are available to repair all vehicles, dealers may only repair customer-owned vehicles in extenuating circumstances and unsold vehicles with a signed sales contact.*

To place an order for the seat frame and related parts, submit a VIN-specific Part Order contact via the SSSC Web Contact Site. Part Order contacts should include images of the seat frame showing missing J-channel bracket(s) and the VIN tag.

Part Number	Description	Order Quantity	Claim Quantity
-78613A10-	Seat frame assembly (vehicle specific)	1	1
W714836-S437M	Seat belt anchor bolt	1	1
W715617-S900	Seat belt buckle bolt	1	1
W520113-S450B	Seat belt retractor nut	1	1
-7863388-	RH Seat frame outer side shield (vehicle specific)	1	1
-7863389-	LH Seat frame outer side shield (vehicle specific)	1	1
-7861348-	RH Seat frame inner side shield (vehicle specific)	1	1
-7861349-	LH Seat frame inner side shield (vehicle specific)	1	1
-7867460-	Seat release handle bezel (vehicle specific)	1	1
-78666B14-	RH Seat track front shield (vehicle specific)	1	1
-78666B15-	LH Seat track front shield (vehicle specific)	1	1

Less than 2% of the affected vehicle population is expected to require seat frame replacement.

NEW VEHICLE DEMONSTRATION / DELIVERY HOLD -

Safety Recall 18S37 - *Supplement #1*

Certain 2018 Model Year Expedition and Navigator Vehicles with 40/20/40 Second Row Seating
Second Row Center Seat Frame Inspection

DEALER PRICE

For latest prices, refer to DOES II.

PARTS RETENTION AND RETURN

Follow the provisions of the Warranty and Policy Manual, Section 1 - WARRANTY PARTS
RETENTION AND RETURN POLICIES.

EXCESS STOCK RETURN

Excess stock returned for credit must have been purchased from Ford Customer Service Division in
accordance with Policy Procedure Bulletin 4000.

CERTAIN 2018 MODEL YEAR NAVIGATOR AND EXPEDITION VEHICLES — SECOND ROW CENTER SEAT FRAME INSPECTION

NEW ! OVERVIEW

In some of the affected vehicles, the second row center seat frame may not have been assembled with one or both of the J-channel brackets in the seat track. A second row center seat frame assembled without a J-channel bracket, and is adjusted at or near the full forward position, may not restrain an occupant properly in the event of a crash. Before demonstrating or delivering any new in-stock vehicles involved in this recall, dealers are to inspect the second row center seat frame track to ensure both J-channel brackets are present. If one or both brackets are missing, dealers will replace the seat frame assembly.

At this time, parts are not available to repair all vehicles; however, less than 2% of the affected vehicle population is expected to require seat frame replacement. Until parts are available to repair all vehicles, dealers may submit an approval request to the SSSC to authorize repairs on customer-owned vehicles in extenuating circumstances and unsold vehicles with a signed sales contact.

NEW ! SERVICE PROCEDURE

Recommended Tool List:

General Tools	
1/4" Drive Ratchet (Power and Hand Tool)	Side Cutters
1/4" Drive T20, T25 and T27 Sockets	Flat Head Screw Driver
3/8" Drive Ratchet (Power and Hand Tool)	Plastic and Metal Retainer/Trim Tools
3/8" Drive 13mm and 15mm Deep Sockets	
3/8" Drive T45 and T50 Sockets	
3/8" Drive 3" and 10" Extension	
1/4" Drive Torque Wrench	
3/8" Drive Torque Wrench	



Second Row Center Seat Frame Inspection Procedure

1. Fold down the second row center seat backrest and tilt both outboard seats forward.
2. Inspect the rearward end of both seat tracks for the presence of j-channel brackets. See Figure 1.
 - Use the seatbelt retractor and the seatbelt buckle anchor bolts as a reference point for the j-channel brackets location as shown in Figure 2.
3. Are the second row center seat track j-channel brackets present?

Yes - Place the second row seat backrest in the upright position. The repair is complete.
No - Proceed to the Second Row Center Seat Frame Replacement Procedure, on Page 3.

NOTE: At this time, dealers may only repair customer-owned vehicles in extenuating circumstances and unsold vehicles with a signed sales contract.

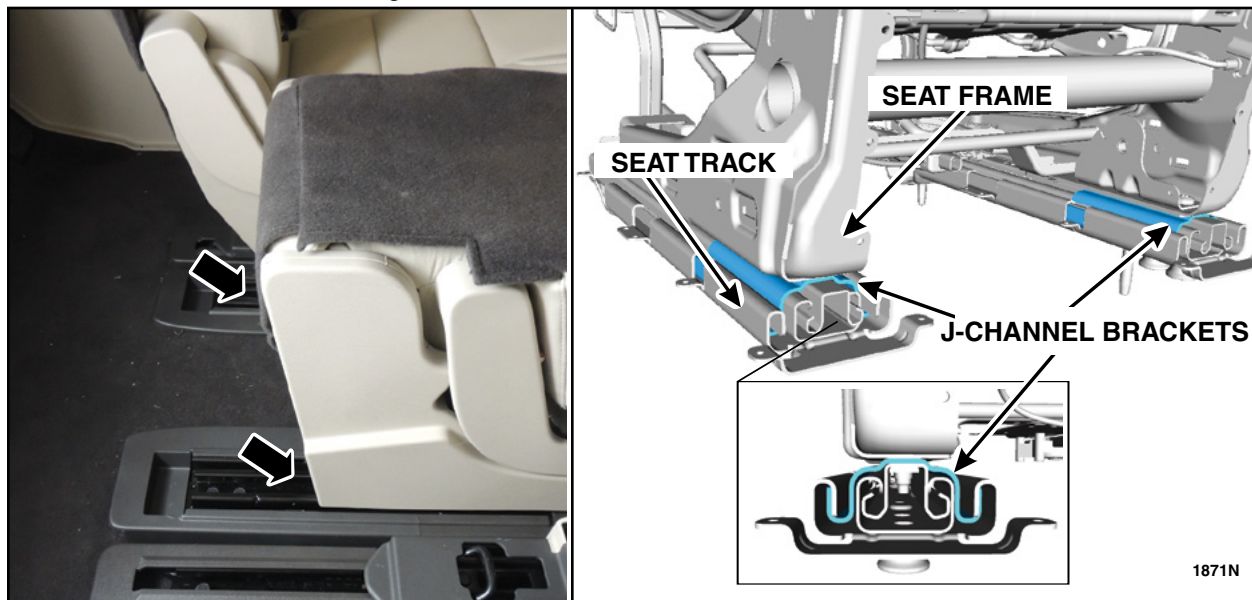

FIGURE 1



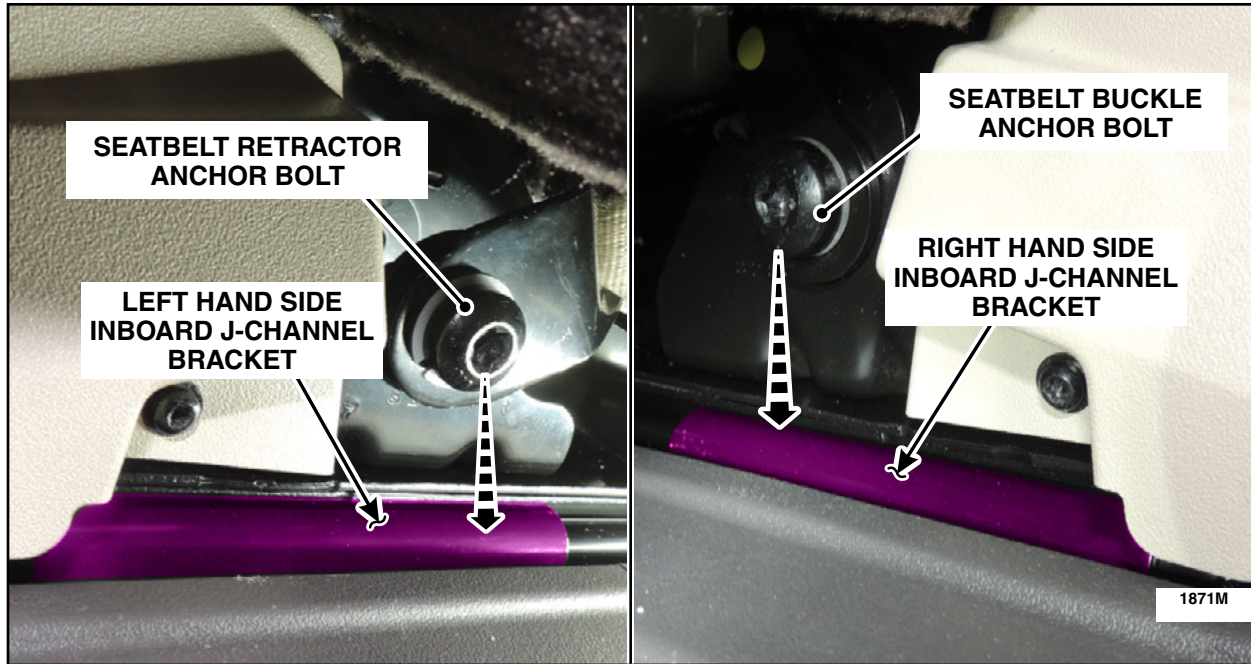

FIGURE 2



NEW ! Second Row Center Seat Frame Replacement Procedure

NOTICE: Hand tools are required for installation of a thread forming fastener. Do NOT use power tools, as the possibility for over-torquing or stripped threads exists. If a fastener is over-torqued, the joint can fail. Please refer to the Workshop Manual (WSM) procedures in Section 100-00 for additional information.

1. Remove the second row center seat. Please follow WSM procedures in Section 501-10.

NOTE: Do not separate the seat cushion cover from the seat cushion foam.

2. Remove the second row center seat cushion cover. Please follow the WSM procedures in Section 501-10.

NOTE: Do not separate the seat backrest cover from the seat backrest foam.

3. Remove the second row center seat backrest cover. Please follow the WSM procedures in Section 501-10.

4. Remove both of the lower second row center seat track shields. See Figure 3.

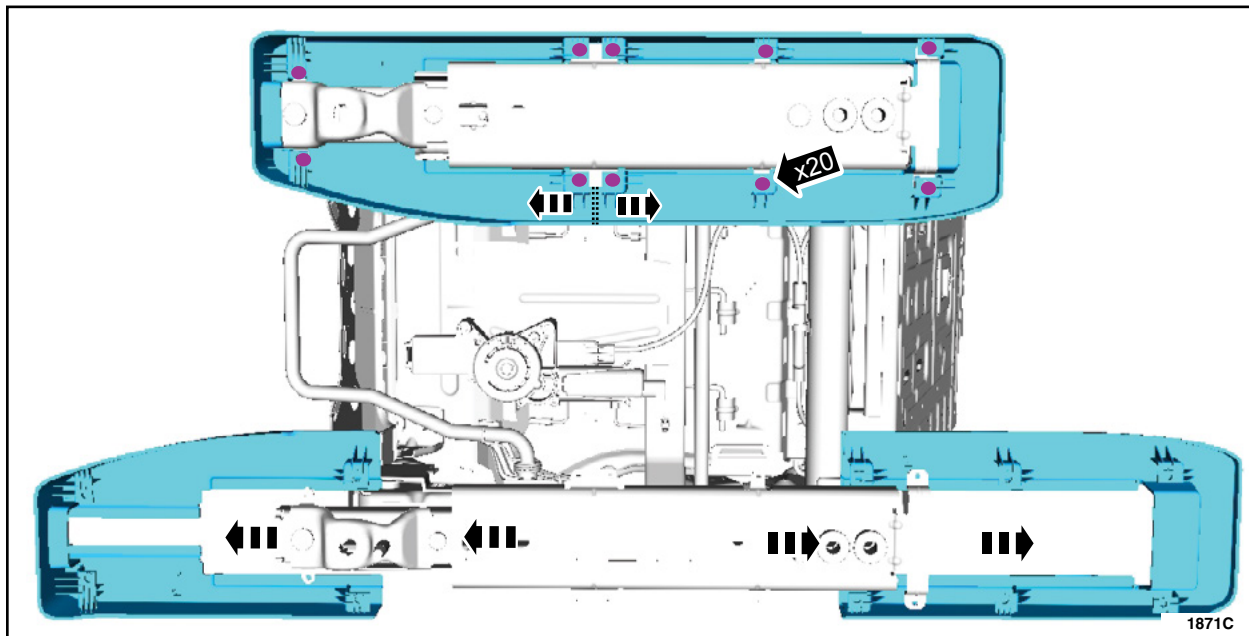

FIGURE 3



5. Remove the push pins and the foam spacer from inside the second row center seatbelt web guide. See Figure 4.

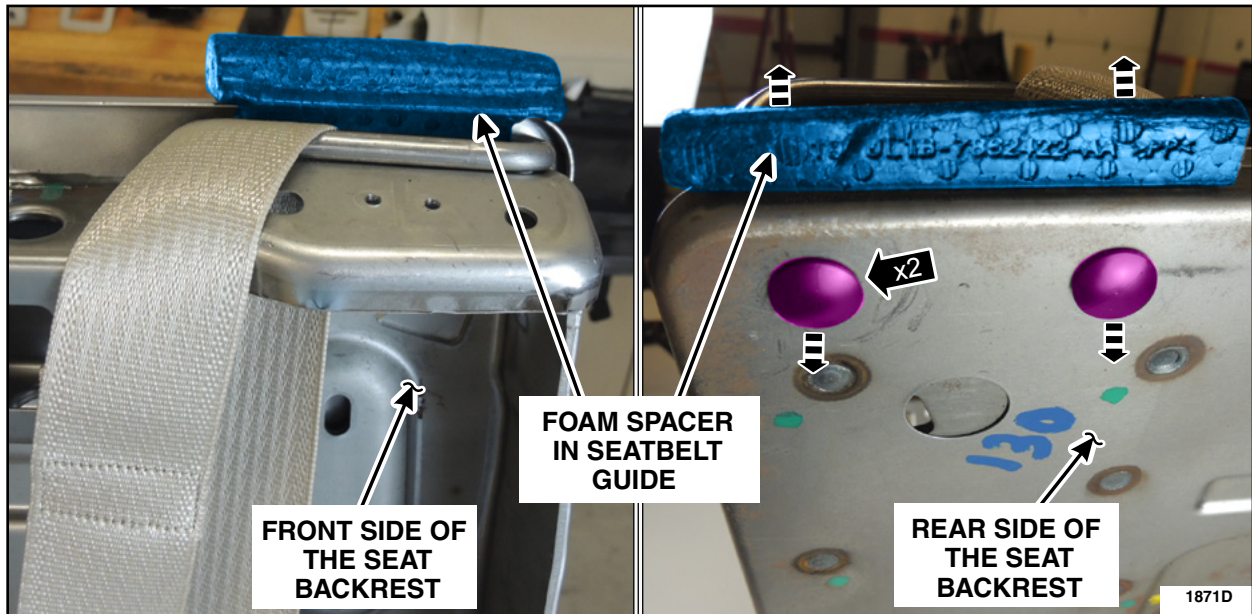

FIGURE 4

6. Remove the second row center seatbelt retractor. See Figure 5.
- Remove and discard the nut.
 - Torque: 30 lb.ft (40 Nm).
 - Feed the seatbelt through the seatbelt guide.

NOTE: During installation, make sure the seatbelt webbing is not twisted and the seatbelts and buckles are accessible to the occupants.

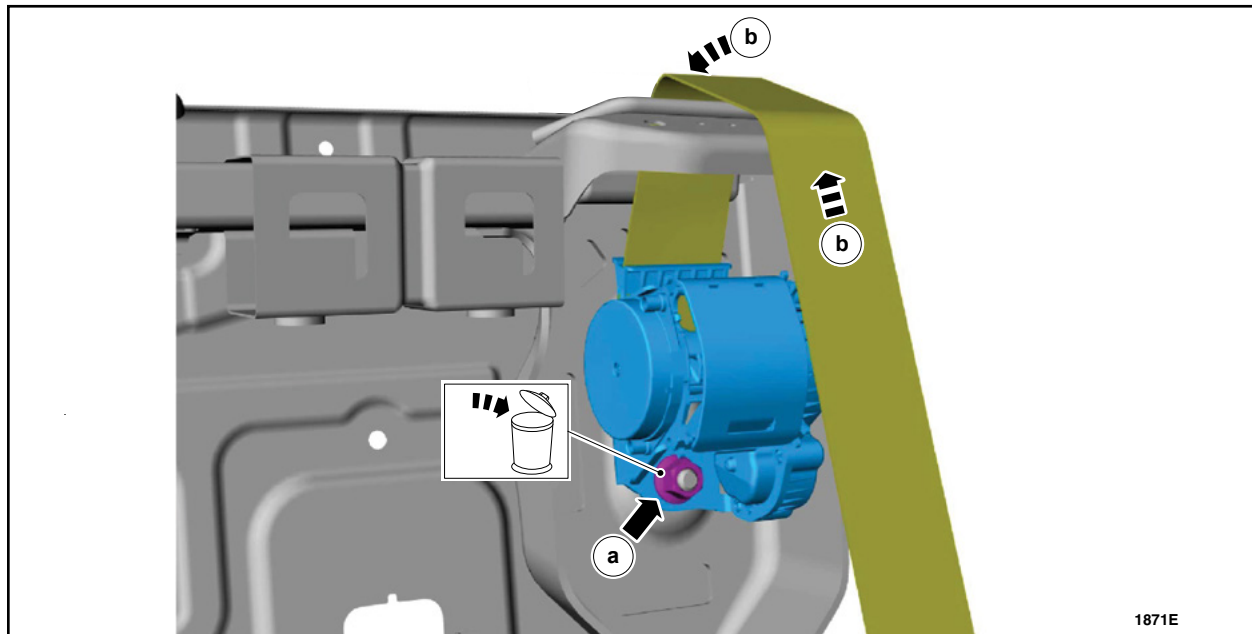

FIGURE 5



7. Remove the retainers and both front seat track shields. See Figure 6.

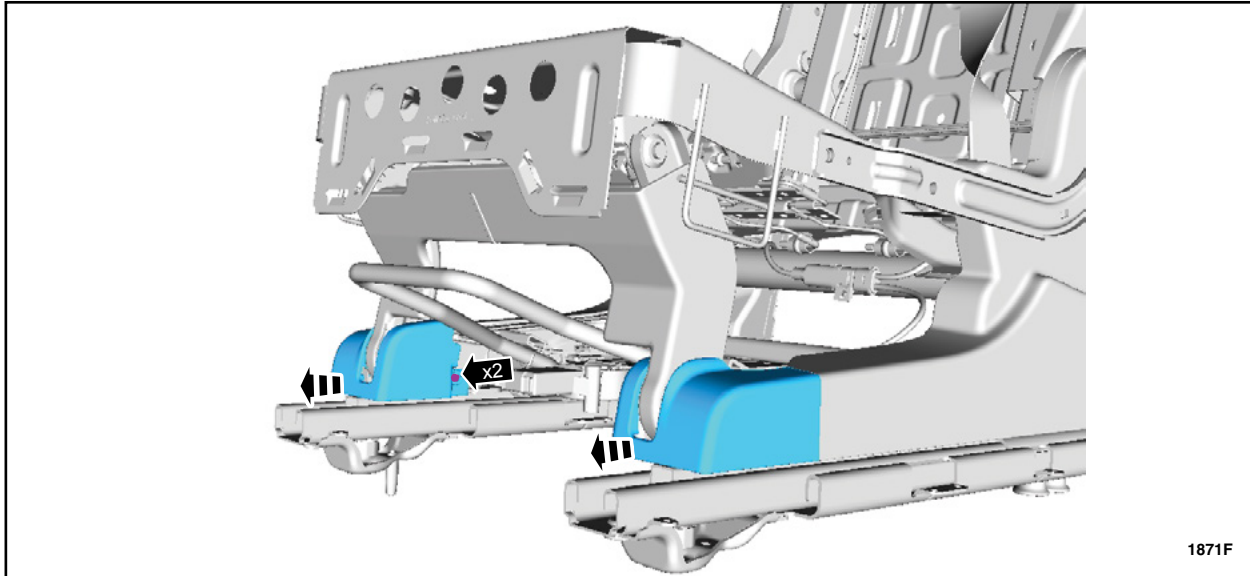

FIGURE 6

8. On both sides, remove the seat cushion frame pivot arm retainer from the seat backrest frame and position the seat cushion frame forward. See Figure 7.

- Torque: 11 lb.ft (15 Nm).

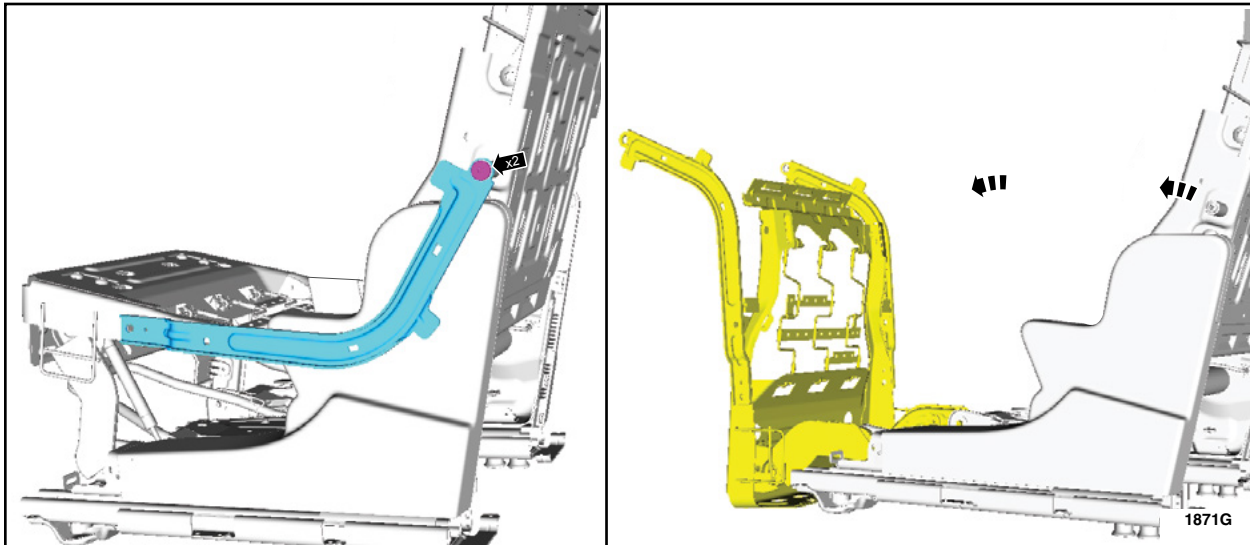

FIGURE 7



9. Remove the retainers and the front crossbar frame panel. See Figure 8.

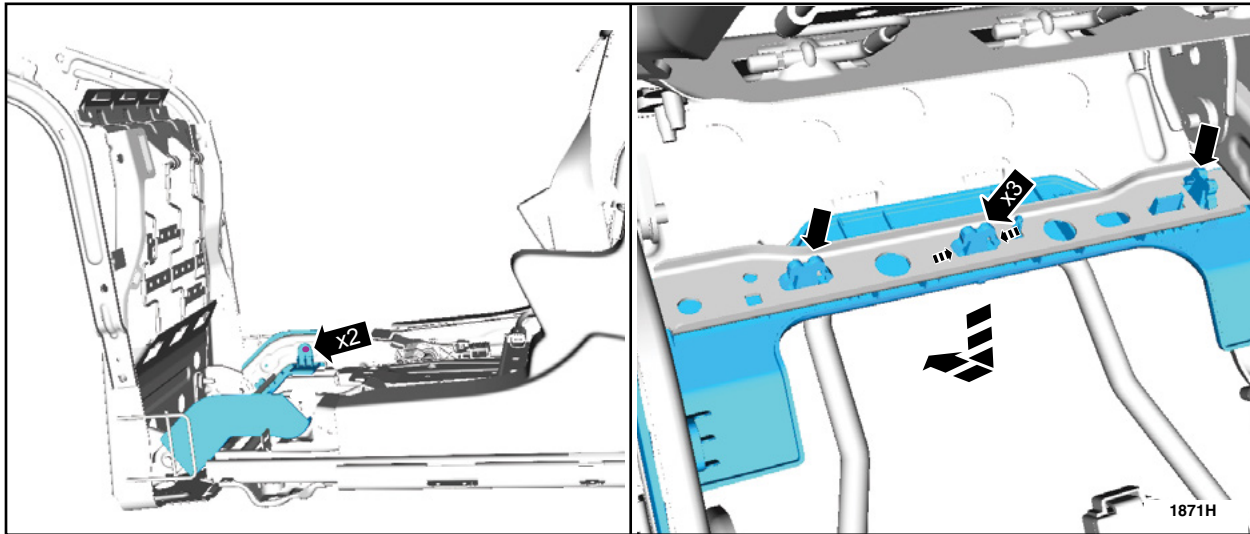

FIGURE 8

10. Remove the retainers and the inner side seat shields. See Figure 9.

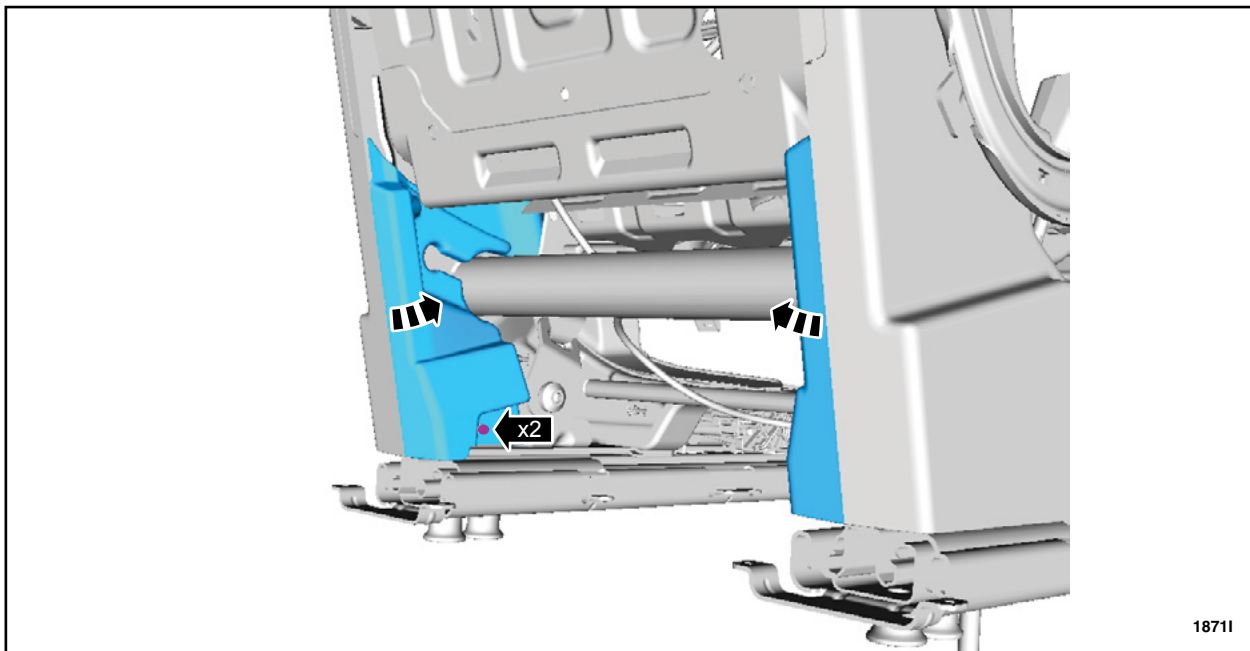

FIGURE 9



11. Remove the rear and the side retainers from the seat outer side shield and remove the shields.
See Figure 10.



FIGURE 10

12. Detach the push pin retainer and disconnect the second row center seatbelt buckle electrical connector. See Figure 11.
13. Remove and discard the second row center seatbelt buckle retainer and position aside the buckle.
See Figure 11.

- Torque: 30 lb.ft (40 Nm).

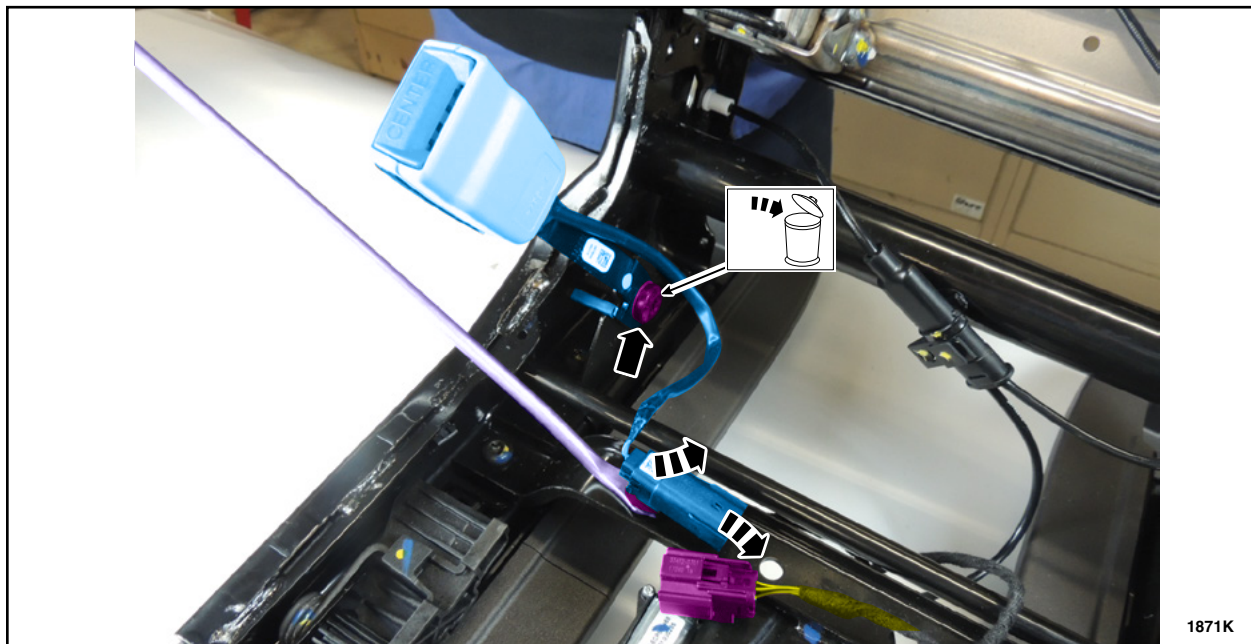

FIGURE 11



14. Disconnect the power release seat actuator motor electrical connector. See Figure 12.
15. Detach the pin-type retainers and remove the seat jumper harness assembly from the seat frame. See Figure 12.

NOTE: Note the jumper harness routing for proper installation.

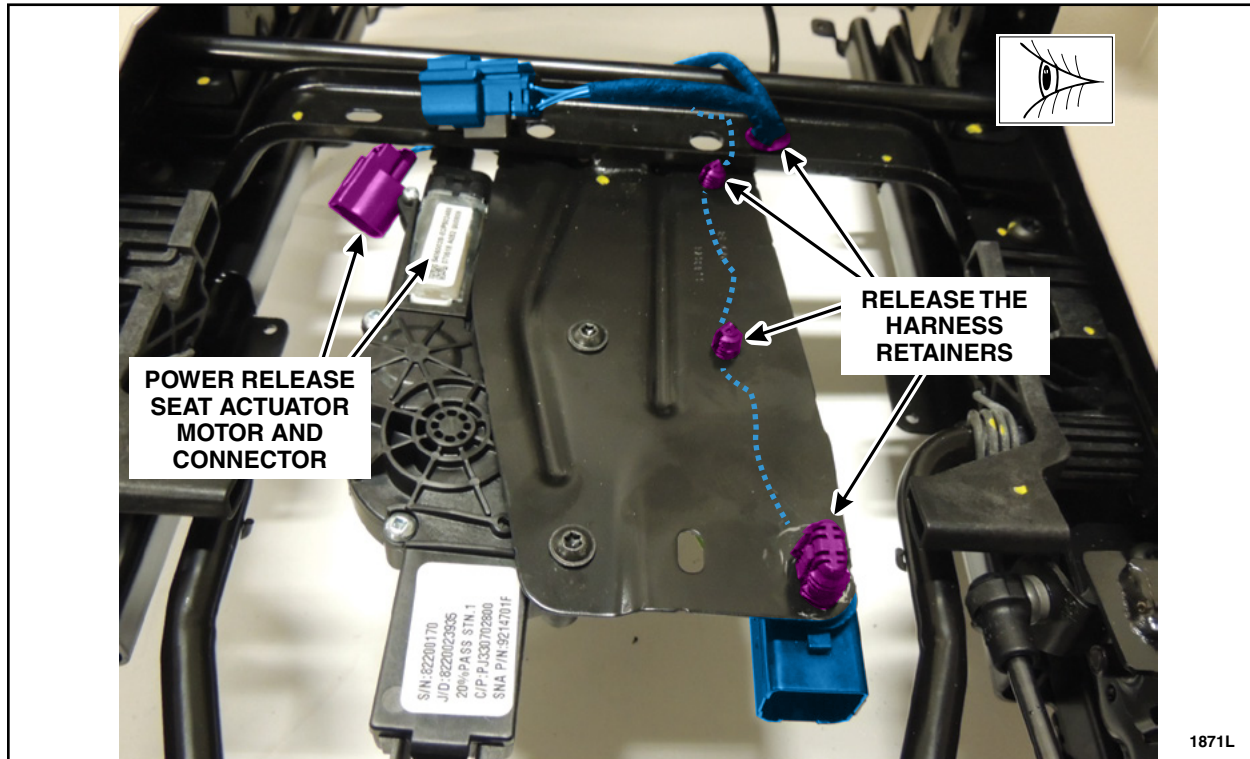

FIGURE 12



NOTE: The replacement frame will be shipped with the seat cushion pivot arms assembled to the seat backrest frame. It will be necessary to remove the replacement frames seat cushion pivot arm retainers before continuing with the installation of the seat components. See Figure 13.

16. On the both sides of the *new* seat frame, remove the seat cushion frame pivot arm retainers from the seat backrest frame and position the seat cushion frame forward. See Figure 13.

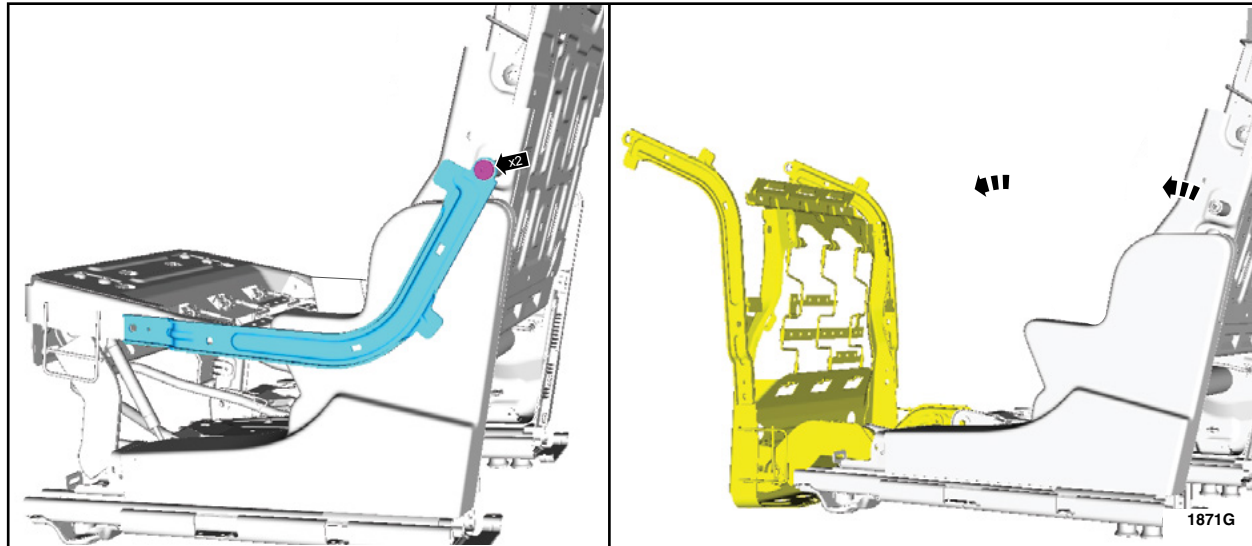

FIGURE 13

17. Install the seat jumper harness assembly to the seat frame. See Figure 12.
18. Connect the power release seat actuator motor electrical connector. See Figure 12.
19. Using a *new* retainer, install the seatbelt buckle. See Figure 11.
20. Connect the seatbelt buckle electrical connector and attach the push pin retainer. See Figure 11.
21. Install the seat outer side shields and the retainers. See Figure 10.
22. Install the inner side seat shields and the retainers. See Figure 9.
23. Install the front crossbar frame panel and the retainers. See Figure 8.
24. Position the seat cushion frame rearward toward the seat backrest frame and install the retainers. See Figure 7.
25. Install the front upper seat track covers and the retainers. See Figure 6.
26. Using a *new* retainer install the seatbelt retractor. See Figure 5.
27. Install the seatbelt guide foam spacer and the push pins. See Figure 4.
28. Install both of the lower seat track shields. See Figure 3.



29. Install the seat backrest cover. Please follow the WSM procedures in Section 501-10.

NOTE: The seatbelt retractor anchor bolt will need to be discarded and a *new* bolt installed.

30. Install the seat cushion cover. Please follow the WSM procedures in Section 501-10.

31. Install the second row center seat. Please follow the Workshop Manual (WSM) procedures in Section 501-10.

