

Automotive

Safety Recall Campaign
SC-82

August 2, 2019
Revised September 13, 2019

Safety and Emissions Recall Campaign "CY" (4011 and 4012) Kizashi Fuel Tank

Affected Models: All 2010 - 2013 Kizashi Models (A6B424)

Affected Departments: Management, Service, Warranty, Parts

Special Note: Repair Procedure begins on [Page 10](#)

This notice is sent to you in accordance with the requirements of the National Traffic and Motor Vehicle Safety Act.

Suzuki Motor Corporation has decided that a defect which relates to motor vehicle safety and emissions control performance exists in 2010 - 2013 model-year Kizashi vehicles.

NOTE:

This CY Campaign supersedes the VG Campaign of 2014, and requires all 2010 - 2013 Suzuki Kizashi vehicles to be repaired. (See "What is the problem?" below for further information.)

SERVICE PROVIDER CAMPAIGN RESPONSIBILITY

Suzuki Service Providers will complete this important safety and emissions recall campaign on all affected vehicles, including branded title vehicles. This repair must be performed regardless of vehicle age or mileage, and at no charge to the customer. When contacted by the customer, Suzuki Service Providers need to schedule an appointment to perform the campaign service and order required parts.

If you have questions, please contact your Suzuki District Service and Parts Manager (DSPM) or the Warranty Assistance Help-Line at (714) 996-7042.

What is the problem?

In 2014, Suzuki initiated a safety and emissions recall (**Recall VG / 14V-464**) for certain 2010 - 2013 model-year Kizashi vehicles. The reason for the safety and emissions recall was that a spider could enter the evaporative emissions canister air vent line and weave a web, causing a restriction in the vent line.

The repair of the safety recall in 2014 involved the installation of a vent line, which incorporated a filter to prevent the entry of spiders.

Suzuki has determined that vehicles equipped with the canister vent hose spider filter (or the original unfiltered vent hose) and operated for extended periods of time on non-paved roads or under extremely dusty conditions can accumulate dust in the vent hose filter, causing a restriction. If the vent hose filter becomes restricted, it could result in excessive negative pressure in the fuel tank, causing deformation and possible cracking of the fuel tank, resulting in a fuel leak. A fuel leak in the presence of an ignition source can cause a fire.

Affected Models:

All 2010 - 2013 Kizashi FWD and Kizashi AWD Models

Verify if the vehicle is affected by the campaign:

Confirm the recall campaign status by checking the VIN on the driver's side dashboard against the Vehicle Master Inquiry in Suzuki Connect to see if the repair needs to be completed. If you have a question regarding vehicle eligibility, contact the Suzuki Motor of America, Inc. (Suzuki) Warranty Department.

What you will do as a Suzuki Service Provider:

- 1) Replace the following:
 - A) Pipe Set, Air Suction
 - B) Tank, Fuel (FWD / AWD)
 - C) Cap Set, Fuel (FWD / AWD)
 - D) Canister Set (depending on inspection results)
- 2) Complete a completion repair sticker and attach it to the vehicle.
- 3) Complete a Vehicle Emission Recall - Proof of Correction card, and give it to the customer at the time of delivery or repair.
- 4) Submit a Long Form warranty claim as instructed on page 5.

IMPORTANT NOTICE FOR CALIFORNIA DEALERS

The California Air Resources Board requires that all applicable emission recall campaigns be completed prior to California registration renewal. If the owner does not have this recall performed, they will not be able to renew their California vehicle registration.

After completing the recall service, your Service Department must give each owner a "Proof of Correction" certificate. If required, the owner must present this certificate to the Department of Motor Vehicles when renewing their California registration.

What Suzuki Motor of America, Inc. (Suzuki) will do:

During the week of August 5, 2019, Suzuki will mail notification letters to owners of affected vehicles for whom we have information. The letter instructs the customer to contact a Suzuki Service Provider to schedule an appointment.

Parts Ordering:

- Parts for this campaign are available now.
- Use the normal parts ordering procedure to order the parts needed for vehicles in your inventory or for customer vehicles in your shop.
- With each parts kit you order for the repair, you will receive 1 repair completion sticker and 1 Vehicle Emission Recall - Proof of Correction certificate. This will include instructions for what to do with these items. (See below for a sample of these instructions. Complete instructions are provide on page 58.)
- If you have any questions related to parts ordering, contact Suzuki National Parts Coordination at (714) 854-2165.
- If additional parts are required to complete the repair due to corrosion or rust, contact Suzuki Tech-Line at 1-800-934-1616 or District Service and Parts Manager Joe Taylor at 1-615-975-8059 for assistance.

Model	Model Year	Part Description	Part Number	Qty
Kizashi FWD	2010 - 2013	Tank, Fuel FWD	89101-57L31-RX0	1
Kizashi FWD	2010 - 2013	Cap Set, Fuel FWD	89101-57810-RX0	1
Kizashi AWD	2010 - 2013	Tank, Fuel AWD	89101-57L81-RX0	1
Kizashi AWD	2010 - 2013	Cap Set, Fuel AWD	89102-57810-RX0	1
Kizashi FWD / AWD	2010 - 2013	Pipe Set, Air Suction	18560-57850-RX0	1
Kizashi FWD / AWD	2010 - 2013	Canister Set	18560-57L11-RX0	1 Depending on inspection

Instructions for Completion Repair Sticker and Vehicle Emission Recall - Proof of Correction certificate

NOTE:

- The recall completion code to be used for the Proof of Correction Certificate is **CY**.
- Only use the code **CY** when filling out the Proof of Correction Certificate that you provide to the customer.
- If the warranty claim number (4011 or 4012) is mistakenly written on the certificate, it will be rejected by the California Department of Motor Vehicles (DMV) and the customer may not be able to renew their vehicle registration.



SUZUKI
SUZUKI MOTOR OF AMERICA, INC.

Dear Suzuki Service Provider,

Please use the enclosed items to complete the 2010 - 2013 Kizashi Fuel Tank Canister Vent Pipe Recall Campaign. After you have completed the repairs, do the following:

Repair Completion Sticker:

All Service Providers:

- 1) Write "CY" in the top box of the repair completion sticker using a permanent marker or pen with black ink such as a Sharpie® brand marker with a fine point.
- 2) Write your six-digit Service Provider Number in the bottom box.
- 3) Attached the sticker to the vehicle as shown below.

KIZASHI CAMPAIGN

CY

SUZUKI SERVICE PROVIDER #

400200

Sample

Attach the repair completion sticker to front bumper/facia, forward of the air cleaner.



For California Dealers:

In addition to attaching a repair completion sticker:

- 1) Complete a Vehicle Emission Recall - Proof of Correction certificate and give it to your customer at the time of delivery. Write "CY" in the Recall Number section of the card.
- 2) Explain to your customer that it is important for them to save this certificate as they may need to provide it to the California Department of Motor Vehicles when renewing their vehicle registration.

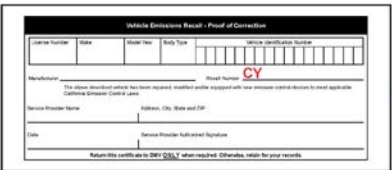

Sample

If your dealership needs more repair completion stickers and/or Proof of Correction certificates, contact your District Service and Parts Manager or Tech-Line at (800) 934-1616.

Identifying Countermeasure Parts

FUEL TANK



*NOTE:
A new fuel tank rollover/inlet valve is included.*

Current Part



Fuel Tank Pad

Countermeasure Part

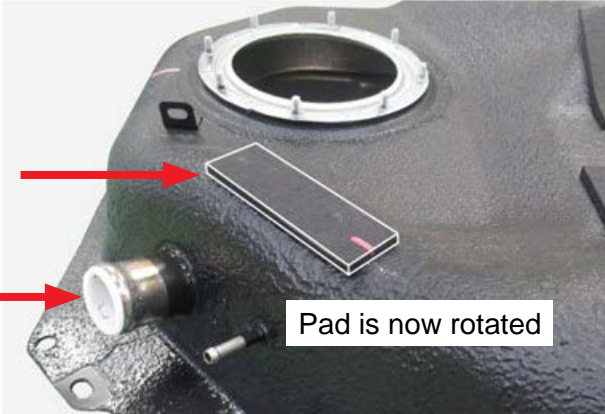

Fuel Tank Pad

Pad is now rotated

FUEL FILLER CAP

Current Part

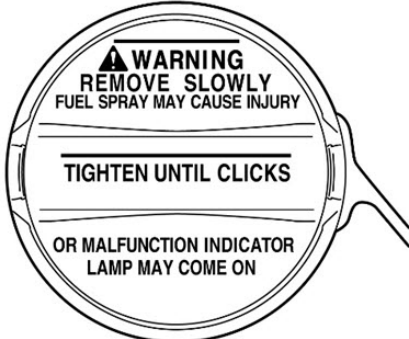

Countermeasure Part

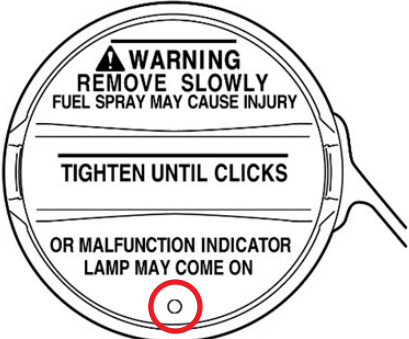

Identification Mark

Warranty Claim Processing:

This safety and emissions recall requires you to submit a Long Form warranty claim – refer to the flow chart below to determine which campaign number you need to file. (Short Form warranty claims will **not** be accepted.)

When the repair is complete, submit the warranty claim on Suzuki Connect using the **FWD** (FWD) warranty claim table on page 6 or the **AWD** warranty claim table on page 7.

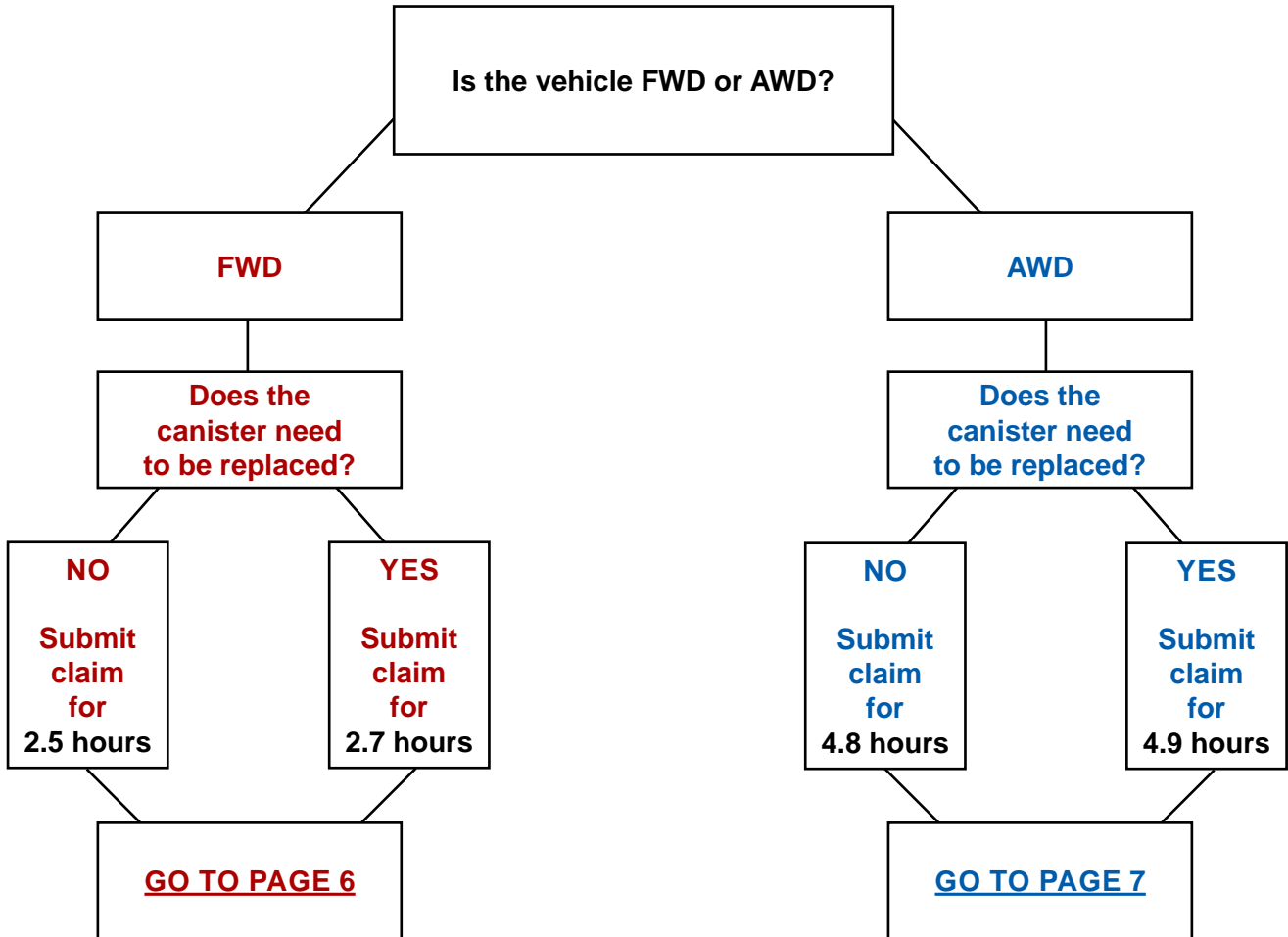

CAMPAIGN 4011 FUEL TANK (FWD) SUZUKI CONNECT LONG FORM INSTRUCTIONS	
CLAIM INFORMATION	
CLAIM NUMBER:	XXXXXX (Service Provider enters number)
ENTRY TYPE:	Vehicle Identification Number (VIN)
VIN:	XXXXXXXXXXXXXXXXXXXX
REPAIR DATE:	Enter date of repair
MILEAGE:	Enter mileage at repair date
CAMPAIGN NUMBER (Choose one):	4011
VARIATION CODE:	
LABOR OPERATION:	Pre-set
LABOR HOURS:	2.5 Hour - 2WD - without replacement of canister - OR - 2.7 Hour - 2WD - with replacement of canister Or as authorized by your Suzuki DSPM
PARTS INFORMATION	
FAILED PART NUMBER:	18560-57850-RX0
REPLACEMENT PARTS AND QUANTITIES:	Tank, Fuel 2WD (PN 89101-57L31-RX0) Cap Set, Fuel 2WD (PN 89101-57810-RX0) Depending on inspection: Canister Set (PN 18560-57L11-RX0) As authorized by your Suzuki DSPM
AUTHORIZATION NUMBER:	Pre-set
FAILURE DESCRIPTION	
DEFECT DESCRIPTION:	
REPAIR DESCRIPTION:	
SUBLET INFORMATION:	

6 / 57

CAMPAIGN 4012 FUEL TANK (AWD) SUZUKI CONNECT LONG FORM INSTRUCTIONS	
CLAIM INFORMATION	
CLAIM NUMBER:	XXXXXX (Service Provider enters number)
ENTRY TYPE:	Vehicle Identification Number (VIN)
VIN:	XXXXXXXXXXXXXXXXXXXX
REPAIR DATE:	Enter date of repair
MILEAGE:	Enter mileage at repair date
CAMPAIGN NUMBER (Choose one):	4012
VARIATION CODE:	
LABOR OPERATION:	Pre-set
LABOR HOURS:	4.8 Hour -4WD - without replacement of canister - OR - 4.9 Hour -4WD - with replacement of canister Or as authorized by your Suzuki DSPM
PARTS INFORMATION	
FAILED PART NUMBER:	18560-57850-RX0
REPLACEMENT PARTS AND QUANTITIES:	Tank, Fuel 4WD (PN 89101-57L81-RX0) Cap Set, Fuel 4WD (PN 89101-57810-RX0) Depending on inspection: Canister Set (18560-57L11-RX0) As authorized by your Suzuki DSPM
AUTHORIZATION NUMBER:	Pre-set
FAILURE DESCRIPTION	
DEFECT DESCRIPTION:	
REPAIR DESCRIPTION:	
SUBLET INFORMATION:	

7 / 57

**CAMPAIGN 4011 FUEL TANK (FWD)
SUZUKI CONNECT LONG FORM INSTRUCTIONS**

CLAIM INFORMATION

CLAIM NUMBER:	XXXXX,X (Service Provider enters number)
ENTRY TYPE:	Vehicle Identification Number (VIN)
VIN	XXXXXXXXXXXXXXXXXX
REPAIR DATE:	Enter date of repair
MILEAGE:	Enter mileage at repair date
CAMPAIGN NUMBER (Choose one)	4011
VARIATION CODE:	JK
LABOR OPERATION:	Pre-set
LABOR HOURS:	2.5 Hour – FWD - without replacement of canister – OR – 2.7 Hour – FWD - with replacement of canister Or as authorized by your Suzuki DSPM

PARTS INFORMATION

FAILED PART NUMBER:	18560-57850-RX0
REPLACEMENT PARTS AND QUANTITIES:	18560-57850-RX0 (Qty 1) – must be the first replaced part number 89101-57L31-RX0 (Tank, Fuel FWD) (Qty 1) 89101-57810-RX0 (Cap Set, Fuel FWD) (Qty 1) Depending on inspection: 18560-57L11-RX0 (Canister Set)
AUTHORIZATION NUMBER:	Required if any parts other than the air suction pipe, fuel tank, or fuel tank cap set are used, or if a different labor time is requested

FAILURE DESCRIPTION

DEFECT DESCRIPTION:	
REPAIR DESCRIPTION:	
SUBLET INFORMATION:	

NOTE:

Only the Long Form warranty claim is available for this campaign. If you attempt to file a Short Form warranty claim, you will see an error message in Suzuki Connect stating that the variation code does not exist.

Do not use a Short Form campaign claim.

REVISED

**CAMPAIGN 4012 FUEL TANK (AWD)
SUZUKI CONNECT LONG FORM INSTRUCTIONS**

CLAIM INFORMATION

CLAIM NUMBER:	XXXXX,X (Service Provider enters number)
ENTRY TYPE:	Vehicle Identification Number (VIN)
VIN	XXXXXXXXXXXXXXXXXX
REPAIR DATE:	Enter date of repair
MILEAGE:	Enter mileage at repair date
CAMPAIGN NUMBER (Choose one)	4012
VARIATION CODE:	JK
LABOR OPERATION:	Pre-set
LABOR HOURS:	4.8 Hour –AWD - without replacement of canister – OR – 4.9 Hour –AWD - with replacement of canister Or as authorized by your Suzuki DSPM

PARTS INFORMATION

FAILED PART NUMBER:	18560-57850-RX0
REPLACEMENT PARTS AND QUANTITIES:	18560-57850-RX0 (Qty 1) – must be the first replaced part number 89101-57L81-RX0 (Tank, Fuel AWD) (Qty 1) 89102-57810-RX0 (Cap Set, Fuel AWD) (Qty 1) Depending on inspection: 18560-57L11-RX0 (Canister Set)
AUTHORIZATION NUMBER:	Required if any parts other than the air suction pipe, fuel tank, or fuel tank cap set are used, or if a different labor time is requested

FAILURE DESCRIPTION

DEFECT DESCRIPTION:	
REPAIR DESCRIPTION:	
SUBLET INFORMATION:	

NOTE:

Only the Long Form warranty claim is available for this campaign. If you attempt to file a Short Form warranty claim, you will see an error message in Suzuki Connect stating that the variation code does not exist.

Do not use a Short Form campaign claim.



SUZUKI MOTOR OF AMERICA, INC.

IMPORTANT SAFETY RECALL

This Notice Applies to Your Suzuki Vehicle Identification Number (VIN)
XXXXXXXXXXXXXXXXXXXX

August 9, 2019

Dear Suzuki Owner:

This notice is sent to you in accordance with the requirements of the National Traffic and Motor Vehicle Safety Act.

Suzuki Motor Corporation has decided that a defect, which relates to motor vehicle safety, exists in 2010 - 2013 model-year Kizashi vehicles. According to our records, you own one of the vehicles affected by this recall.

What is the problem?

In 2014, Suzuki initiated a safety and emissions recall (**Recall VG / 14V-464**) for certain 2010 - 2013 model-year Kizashi vehicles. The reason for the safety and emissions recall was that a spider could enter the evaporative emissions canister air vent line and weave a web, causing a restriction in the vent line.

The repair for the safety recall in 2014 involved the installation of a vent line, which incorporated a filter to prevent the entry of spiders.

Suzuki has determined that vehicles equipped with the canister vent hose spider filter (or the original unfiltered vent hose) and operated on non-paved roads or under dusty conditions can accumulate dust in the vent hose filter, causing a restriction. If the vent hose filter becomes restricted, it could result in excessive negative pressure in the fuel tank, causing deformation and possible cracking of the fuel tank, resulting in a fuel leak. A fuel leak in the presence of an ignition source can cause a fire.

IMPORTANT NOTICE FOR CALIFORNIA RESIDENTS

The California Air Resources Board requires that all applicable emission recall campaigns be completed prior to California registration renewal. If you do not have this recall campaign performed, you will not be able to renew your California vehicle registration.

After completing the recall service, your California Suzuki dealer will give you a "Proof of Correction" certificate. If required, present this certificate to the Department of Motor Vehicles when renewing your California registration.

What is Suzuki Motor of America, Inc. (Suzuki) doing to solve the problem?

Your Suzuki Service Provider will replace the fuel tank and fuel cap, and if necessary, the canister set. Depending on whether your Kizashi is a two-wheel drive or four-wheel drive model, the repair procedure will take approximately 3 - 5 hours to complete. Parts are available now, and there will be no charge to you for any recall campaign service-related parts or labor.

What you should do:

Make sure you are prepared for the service by taking the following steps:

- Before taking your vehicle to your Suzuki Service Provider, contact them as soon as possible to set up an appointment for the service.
- We suggest that you bring this letter to your Suzuki Service Provider to help them process your vehicle for repair.

What to do if you receive this notice in error:

This notice was mailed to you according to the most current information we have available. If you no longer own the Suzuki vehicle described in this letter, please forward this campaign information to the current owner (if known), or contact the Suzuki Automotive Customer Relations Department at (714) 572-1490.

Federal regulations require that any vehicle lessor receiving this campaign notice must forward a copy of this notice to the lessee within ten days.

Customer reimbursement for repairs prior to this Safety Recall Notification:

If your vehicle is included in this recall and you have paid for repairs to address the defect that led to this recall, you may be eligible for full or partial reimbursement. Please note the following conditions for reimbursement:

- Only repairs made to address the defect that led to this recall are reimbursable. Additional expenses such as towing, car rental, accommodations, damage repairs, etc., will not be reimbursed. Reimbursement will not be provided for routine scheduled maintenance.
- Reimbursement may be limited to the suggested list price for parts, the Suzuki published flat-rate time allowance for the repair, and the labor rate that an authorized Suzuki Service Provider in the same area would charge for the same repair.
- An owner will not be eligible for reimbursement if the expenses for repairs are incurred more than 10 days after the date of this notice.
- Reimbursement claims may also be excluded when adequate documentation is not submitted by the claimant. This includes a proof of ownership, a repair order, and proof of payment for the repair.

To apply for reimbursement, contact Suzuki's Customer Service Department at (714) 572-1490.

Who to contact if you experience problems:

Your Suzuki Service Provider can provide you the fastest response to your questions or concerns about this safety recall campaign. If you have any difficulty with this recall campaign, you may contact Suzuki's Customer Service Department for assistance at (714) 572-1490 during the hours of 7:00 AM to 4:30 PM Pacific Time. Please have your vehicle identification number (VIN) ready when calling. The VIN for your vehicle is listed at the top of this notice.

If you need to locate your nearest Suzuki Service Provider, please visit **www.suzuki.com**, click on **Automotive**, followed by the **Service Provider** tab at the top of the web page.

If you believe that Suzuki has failed to provide the safety recall campaign service without charge or is unable to do so within a reasonable time, you may submit a complaint to the Administrator of the National Highway Traffic Safety Administration, 1200 New Jersey Ave., S.E., Washington D.C., 20590 or call the toll-free Vehicle Safety Hotline at 1-888-327-4236 (TTY: 1-888-424-9153) or go to www.safercar.gov.

We apologize for any inconvenience this recall campaign causes you. We hope you understand that your safety and satisfaction are important priorities for us.

Sincerely,

Suzuki Motor of America, Inc.

NECESSARY TOOLS

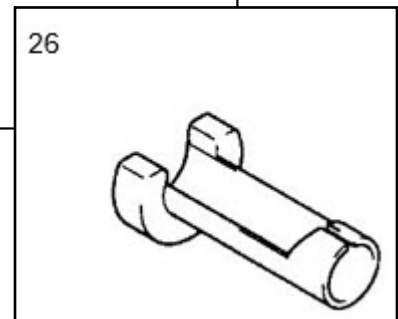

No.	Tool name	No.	Tool name
1	Box-end wrench (10 mm)	13	Socket (17 mm, 12.7 sq)
2	Box-end wrench (12 mm)	14	Socket (Deep type, 22 mm, 12.7 sq)
3	Box-end wrench (14 mm)	15	Flat-bladed screwdriver (medium)
4	Ratchet handle (9.5 sq)	16	Phillips screwdriver (medium)
5	Extension bar (250 mm, 9.5 sq)	17	Pen
6	Extension bar (75 mm, 9.5 sq)	18	Torque wrench (9.5 sq, 8 – 60 N•m)
7	Socket (10 mm, 9.5 sq)	19	Torque wrench (12.7 sq, 40 – 200 N•m)
8	Socket (12 mm, 9.5 sq)	20	Spinner handle (12.7 sq)
9	Socket (14 mm, 9.5 sq)	21	Pliers
10	Socket (17 mm, 9.5 sq)	22	Wire hook
11	Hexagon Socket (6mm, 9.5 sq)*1	23	Lift Table
12	Extension bar (150 mm, 12.7 sq)	24	Transmission jack
25	Electronic Scale (1.0 g / 0.05 oz. accuracy)	26	*Quick Joint Remover (P/N 09919-47020)

**The Quick Joint Remover is included in the countermeasure parts kit.*

REPLACEMENT PARTS



No.	Replacement Parts Set	Parts No.	Contents	Qty
1 - 1	Pipe Set, air Suction 2	18560-57850-RX0	Pipe Comp, Suct (Valve to Fltr)	1
1 - 2			Cap, air Suction	1
1 - 3			Bracket, Suction Filter No. 1	1
1 - 4			Bracket, Suction Filter No. 2	1
1 - 5			Cover, Rear Lining Front	1
1 - 6			Bolt, Filter Bracket	4
1 - 7			Nut, Filter Bracket	1
1 - 8			Screw, Lining Cover	1
1 - 9			Clip, Lining Cover	1

NEWLY ADDED PARTS FOR FWD MODELS



3-1		3-2		3-3	
3-4		3-5		3-6	
3-7		3-8			

No.	Replacement Parts Set	Parts No.	Contents	Qty
2	Tank, Fuel FWD	89101-57L31-RX0	Tank Assy, Fuel	1
3 - 1	Cap Set, Fuel FWD	89101-57810-RX0	Filter, Cstr Air Suction	1
3 - 2			Bolt, Fuel Tank Retaining Strap	4
3 - 3			Gasket, Exh Pipe	1
3 - 4			Gasket, Exh Pipe	2
3 - 5			Gasket, Fuel Pump	1
3 - 6			Quick Joint Remover	1
3 - 7			Cap Assy, Fuel	1
3 - 8			Nut, Main Floor Undercover	18

NEWLY ADDED PARTS FOR AWD MODELS



<p>5-1</p> 	<p>5-2</p> 	<p>5-3</p> 	<p>5-4</p> 	<p>5-5</p> 
<p>5-6</p> 	<p>5-7</p> 	<p>5-8</p> 	<p>5-9</p> 	<p>5-10</p> 
<p>5-11</p> 	<p>5-12</p> 	<p>5-13</p> 	<p>5-14</p> 	<p>5-15</p> 
<p>5-16</p> 	<p>5-17</p> 			

No.	Replacement Parts Set	Parts No.	Contents	Qty
4	Tank, Fuel AWD	89101-57L81-RX0	Tank Assy, Fuel	1
5 - 1	Cap Set, Fuel AWD	89102-57810-RX0	Filter, Cstr Air Suction	1
5 - 2			Gasket, Fuel Pump	1
5 - 3			Bolt, Fuel Tank Retaining Strap	4
5 - 4			Bolt, Center Support	4
5 - 5			Quick Joint Remover	1
5 - 6			Cap Assy, Fuel	1
5 - 7			Gasket, Exh Pipe	1
5 - 8			Bolt, Propeller Shaft	6
5 - 9			Nut, Rear Spnsn Frame Front	4
5 - 10			Bolt, Rear Spnsn Frame Rear	2
5 - 11			Bolt, RR Frame Bar Fr	4
5 - 12			Bolt, RR Spnsn Trlg Arm Fr	4
5 - 13			Gasket, Exh Pipe	2
5 - 14			Bolt, Propeller Shaft Rear	4
5 - 15			Gasket, Fuel Level Gauge	1
5 - 16			Nut, Heat Protector Panel	6
5 - 17			Nut, Main Floor Undercover	18

6



NOTE:
The canister should only be replaced based on the test results of page 43.

6	Canister Set 1	18560-57L11-RX0	Canister	1
---	----------------	-----------------	----------	---

REVISED

IDENTIFYING COUNTERMEASURE PARTS

FUEL TANK



*NOTE:
A new fuel tank rollover/inlet valve is included.*

Current Part



Fuel Tank Pad

Countermeasure Part

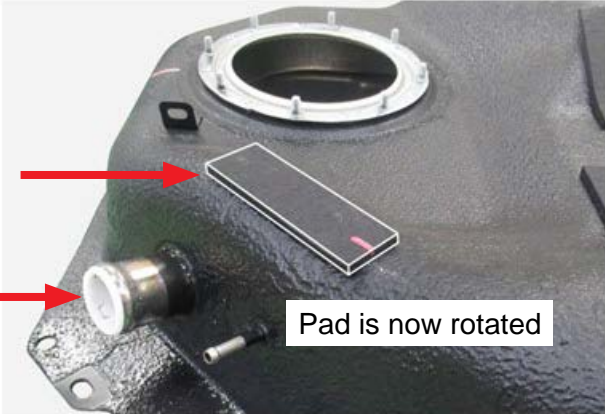

Fuel Tank Pad

Pad is now rotated

Fuel Filler Cap

Current Part

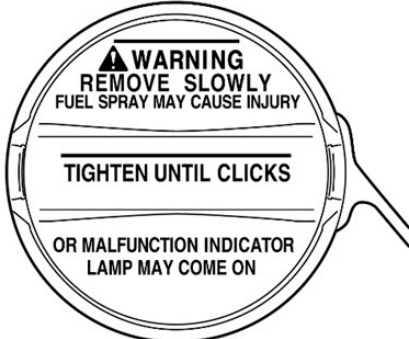

Countermeasure Part

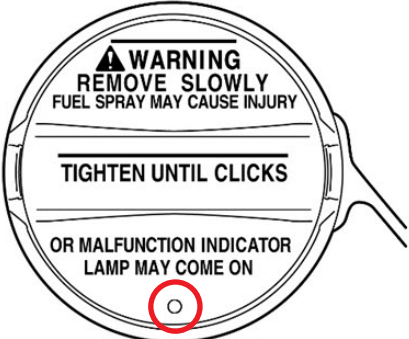

Identification Mark

REPAIR PROCEDURE

WARNING

Service operation of any type performed on the fuel system involves a risk of fire and personal injury if proper precautions are not taken.

Take the following safety precautions whenever working on the fuel system:

- Disconnect the negative cable from the battery.
- Do not smoke. Put up no smoking signs around the work area.
- Have CO2 fire extinguishers handy.
- Perform service operations only in a well-ventilated area away from any open flames such as gas water heaters.
- Wear safety glasses.
- When disconnecting a fitting on the fuel line, cover the fitting with a shop cloth to soak up the small amount of fuel that may flow out from the disconnected fuel line. Put the used cloth in an approved container.
- Never perform service work when engine and exhaust system are hot.
- Since fuel hose connections vary with the pipe type, connect and clamp each hose using the correct method for each specific connection.
- After connecting a hose, check that there is no twist or kink in the hose.

FUEL TANK REMOVAL

- 1) Write down the customer's radio presets.
- 2) Relieve the fuel pressure in the fuel feed line as follows:

NOTICE

Performing this procedure when the engine is still hot can damage the catalyts.

Wait until the engine has cooled down before performing this procedure.

- a) Make sure the engine and exhaust are cool to allow safe engine repair.
- b) For M/T (manual transmission) models, shift the transmission into **Neutral**, apply the parking brake, and block the drive wheels.

For CVT (continuously variable transmission) models, place the shift lever into **Park**, apply the parking brake, and block the drive wheels.

- c) Remove the fuel pump relay (2) from the main fuse box (1).

Set the fuel pump relay aside until the repairs are complete.

- d) Remove the fuel filler cap to release fuel vapor pressure from the fuel tank, then reinstall the fuel filler cap.

- e) Start the engine and run it until the engine stops for lack of fuel. Crank the engine 2 - 3 times for 3 seconds each to dissipate fuel pressure in the fuel lines.

- f) Install the fuel pump relay (2) in the main fuse box and install the main fuse box cover.

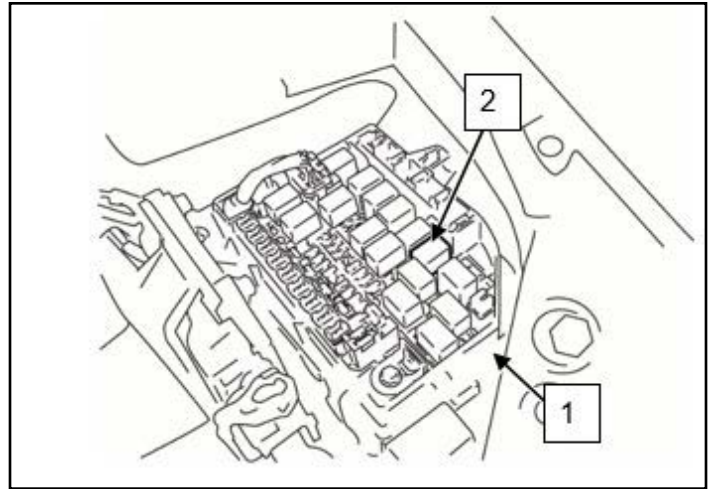

- 3) Disconnect the negative (-) battery cable.
- 4) Safely remove the excess fuel from the fuel tank. Pump out the fuel (1) in space "a" as shown to the right.

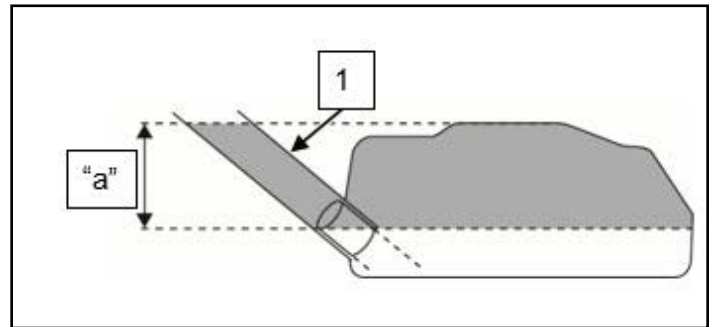

⚠ WARNING

There is a risk of fire or explosion due to static electricity if the drained fuel is stored in an open container or plastic container.

Store the fuel in a sealed metal container.

NOTICE

The hose of a hand-operated pump can damage the fuel tank inlet valve if excessive force is applied when inserting or removing it from the fuel tank.

Do not apply excessive force when inserting or removing the hose of a hand-operated pump.

5) Raise the vehicle on a lift.

6) Remove the vehicle's undercover by removing the bolts (1), nuts (2 - discard these), and clips (3) as shown below.

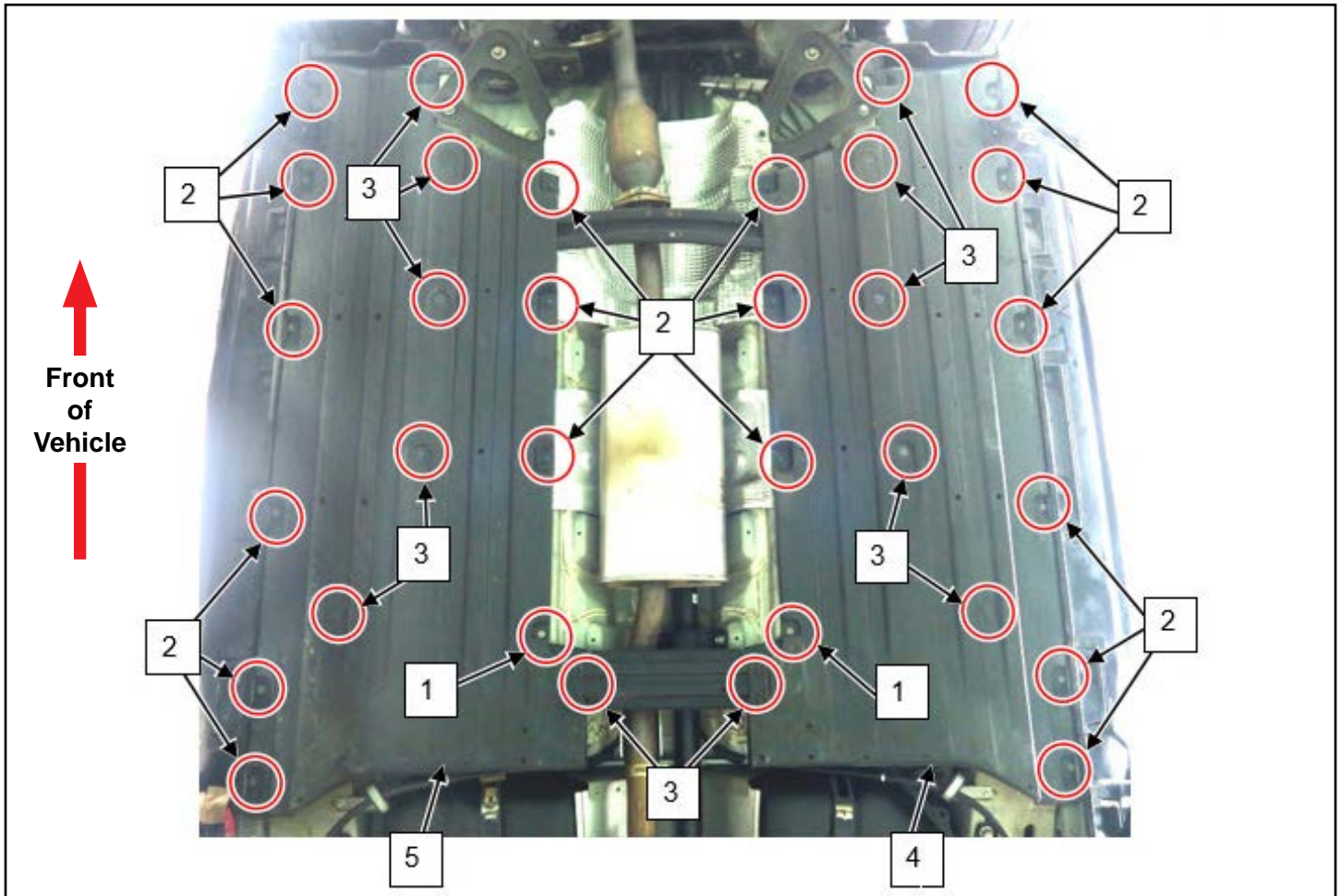

7) Remove the bolts (1) and rear brace (2).

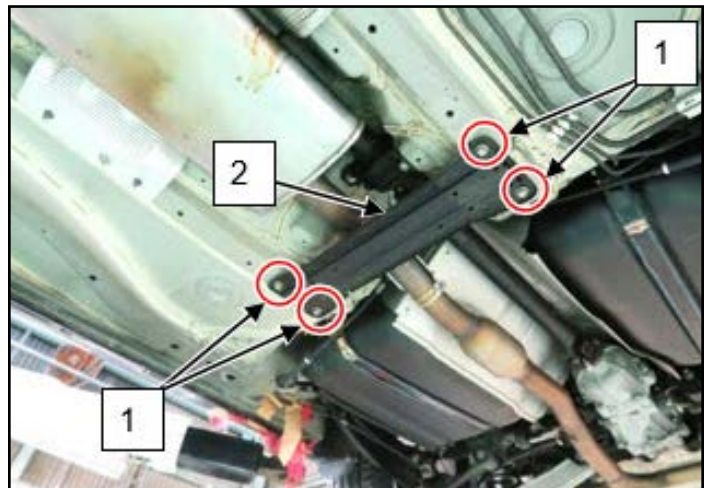

8) Remove the bolts (1) and front brace (2).

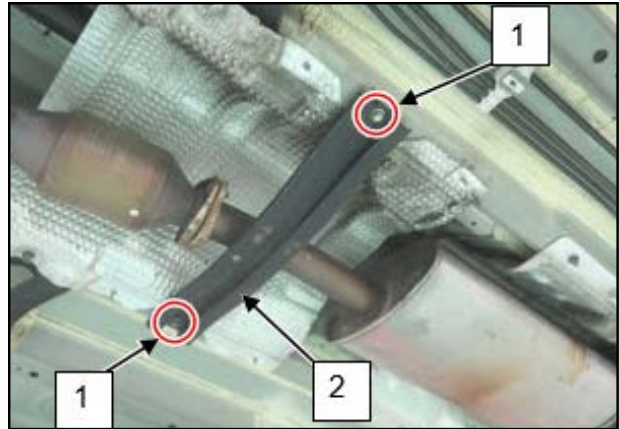

9) Remove the bolts (1) and side engine under-cover on the left (2) and right (3) sides.

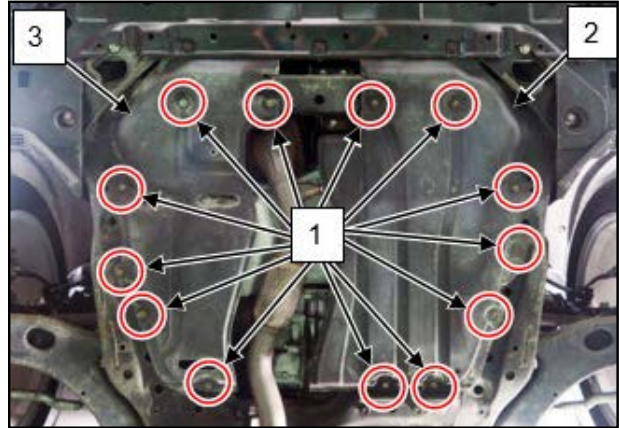

10) Disconnect the HO2S connector (1).



11) Remove the bolts (1), then remove the exhaust support bracket (2).

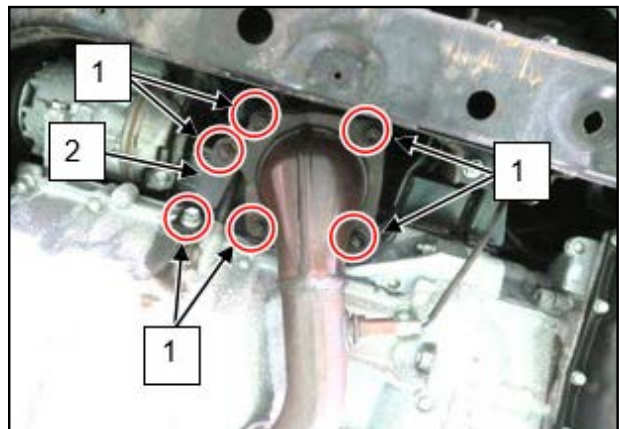

NOTE:

This is the preferred location for removing the exhaust system from the vehicle. Removing exhaust pipe No. 2 from exhaust pipe No. 1 is not recommended.

CAUTION

Touching a hot exhaust system component will cause a burn.

Do not perform any service work on the exhaust system until the exhaust system is cool.

REVISED

12) Remove the exhaust pipe No. 2 nuts (1).

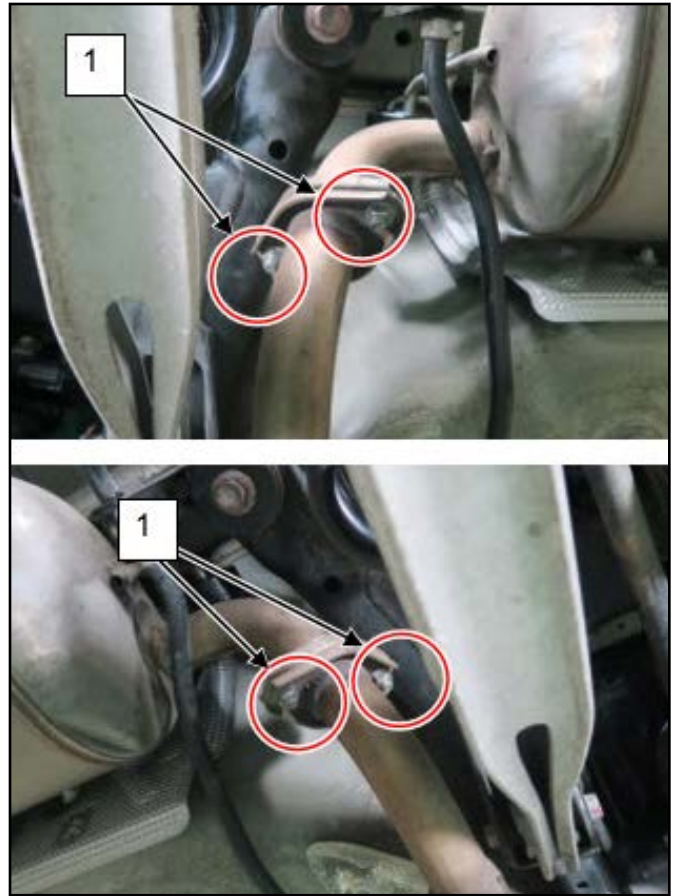

13) Support the exhaust system with a transmission jack (1).

14) Remove the exhaust pipe from mounting No. 1 (2) and No. 2 (3).

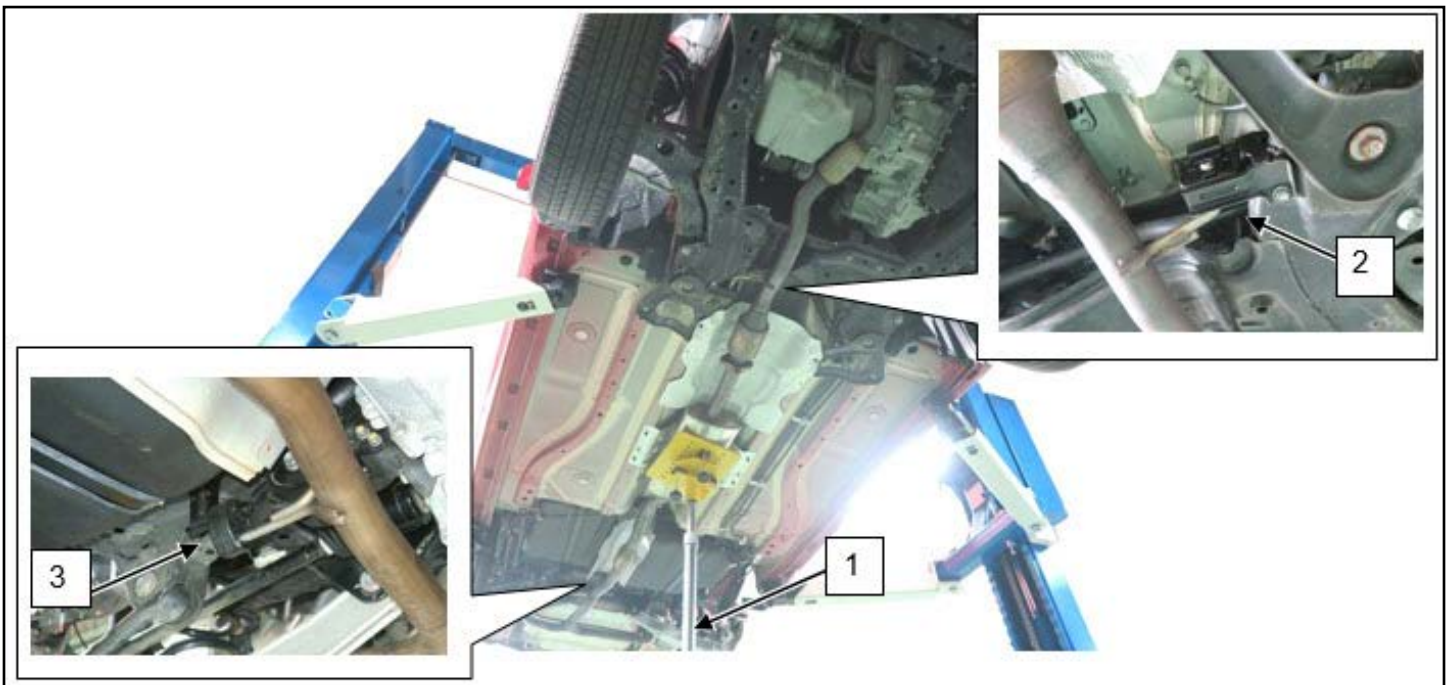

- 15) Remove the exhaust pipe gaskets (1) and discard them.

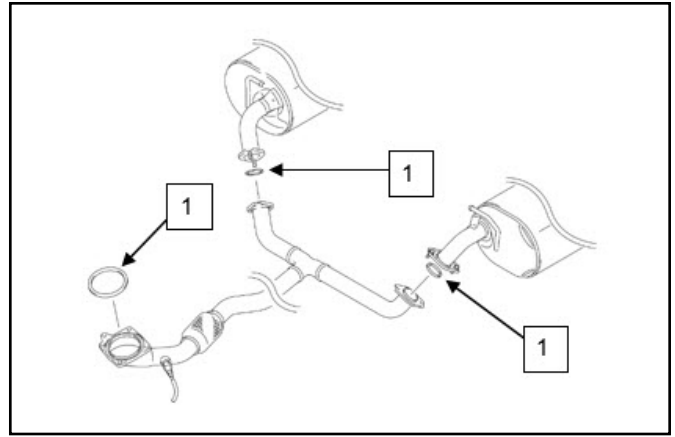

- 16) Detach the parking brake cable clamps (1) from the body.

AWD models

– proceed to Step 17.

FWD models

– proceed to Step 19.

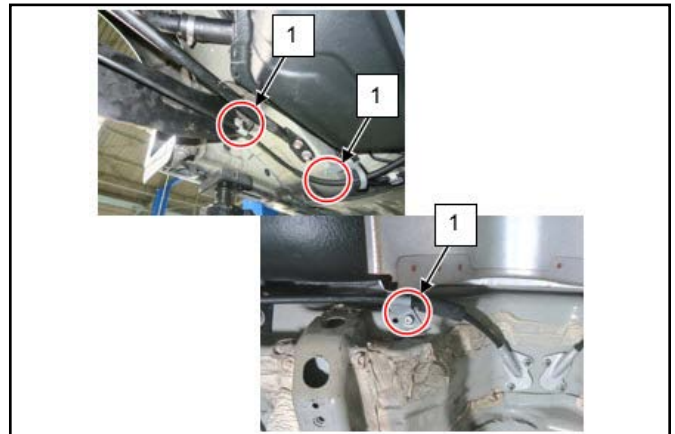

- 17) For AWD models, remove the propeller shaft as follows:

- a) For CVT models, place the shift lever in **Neutral**.
- b) Release the parking brake.
- c) Remove heat shield panel No. 1 (1).

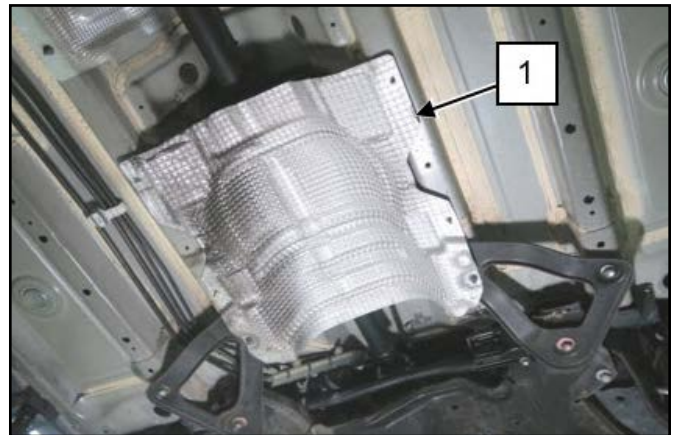

- d) Make a match mark (2) on the joint flange and the propeller shaft (1) as shown.
- e) Remove the propeller shaft bolts (3) and discard them.

Separate the propeller shaft assembly from the transfer case output flange.

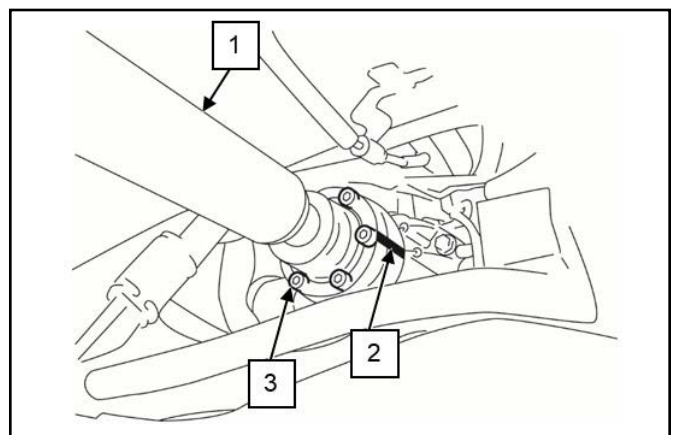

- f) Make a match mark (2) on the joint flange and propeller shaft (1) as shown.
- g) Remove the propeller shaft bolts (3) and discard them.

Separate the propeller shaft assembly from the differential pinion flange.

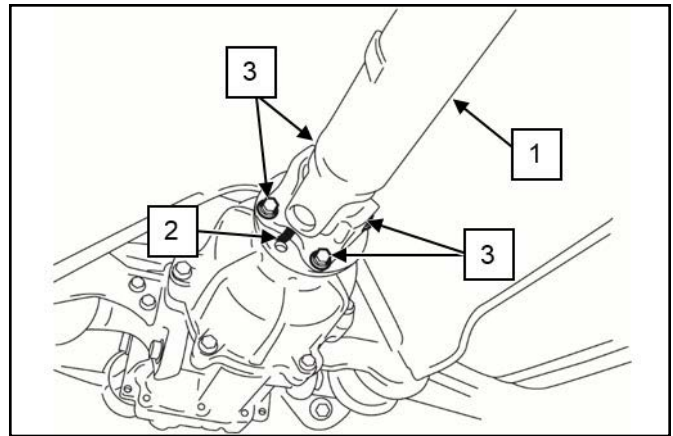

- h) Remove the propeller shaft by removing the center support bolts (1) and discard them.

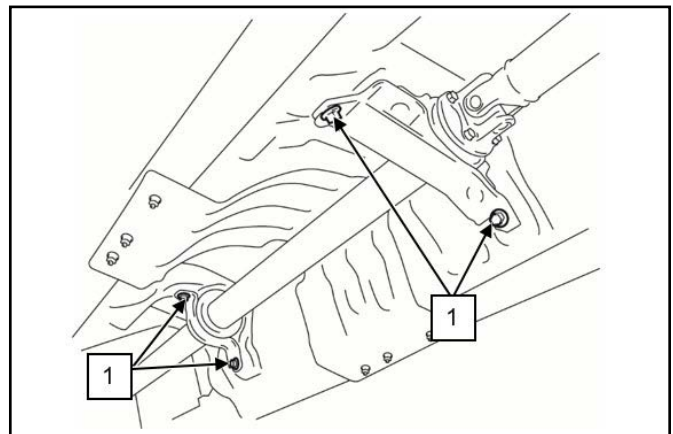

18) Remove the rear suspension frame as follow:

- a) Remove the left and right rear wheels.
- b) Remove the left wheel house liner.

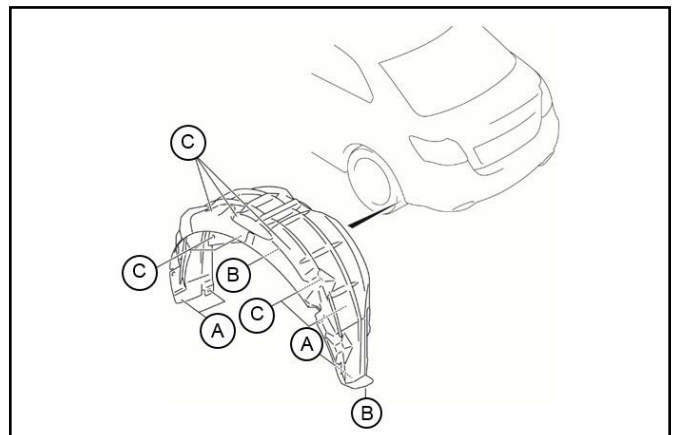

NOTE:

The rear fender lining is secured with three types of clips. Refer to the illustrations shown to the right.

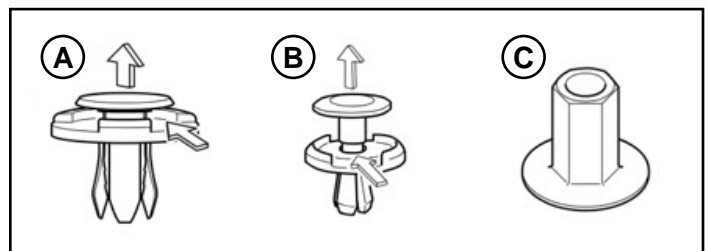

- c) Remove the left and right side shock absorber supports bolts (1).

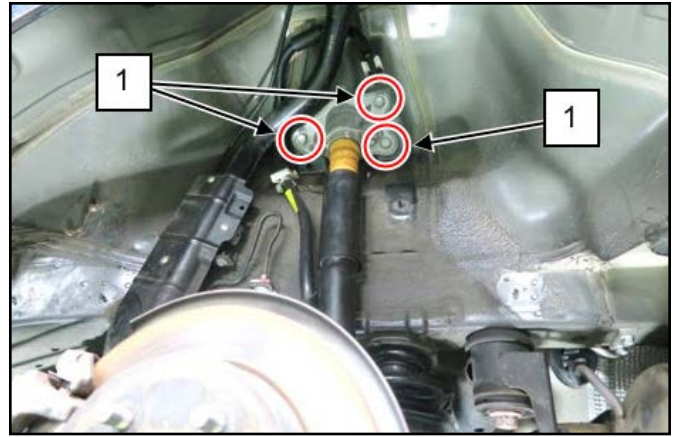

- d) Remove the left and right side rear brake caliper pin bolts (1).

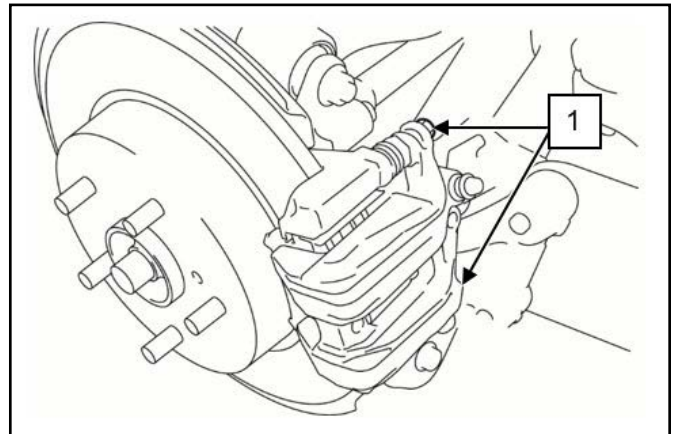

- e) Remove the left and right side rear brake calipers (1) from the rear brake caliper carriers, and suspend them with wire hangers.

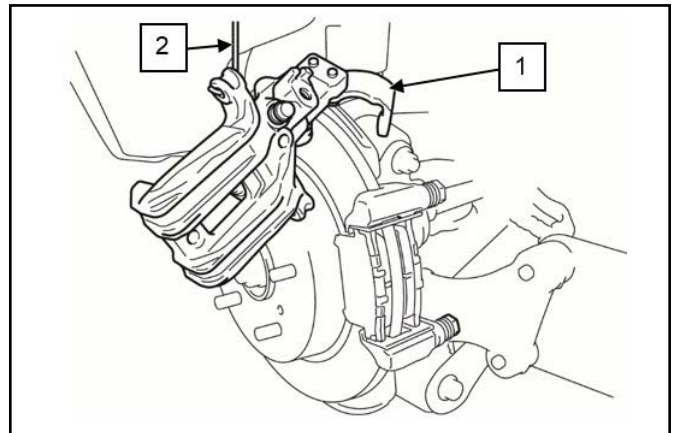

NOTICE

If the removed brake caliper is left hanging by the brake hose, the brake hose may be damaged due to the tension caused by the caliper's weight.

Suspend the removed brake caliper with a wire hook (2) or equivalent to relieve the brake hose of the tension.

- f) Disconnect the coupling assembly connector (1) and coupling air temperature sensor connector (2).

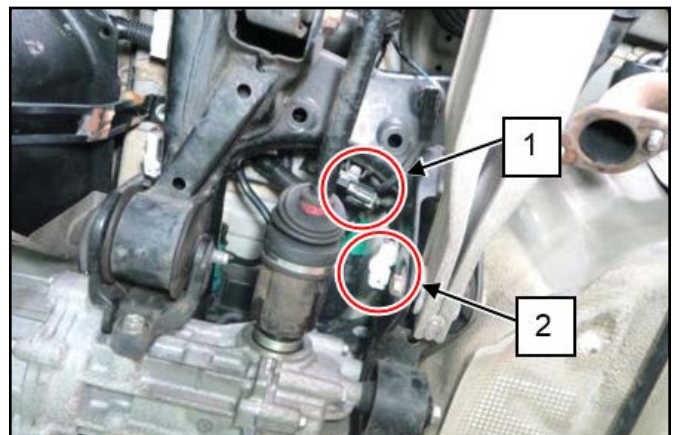

- g) Remove the left and right side frame front bar front bolts (1) and frame front bar rear nut (2) and discard them.

Set aside the frame front bar (3).

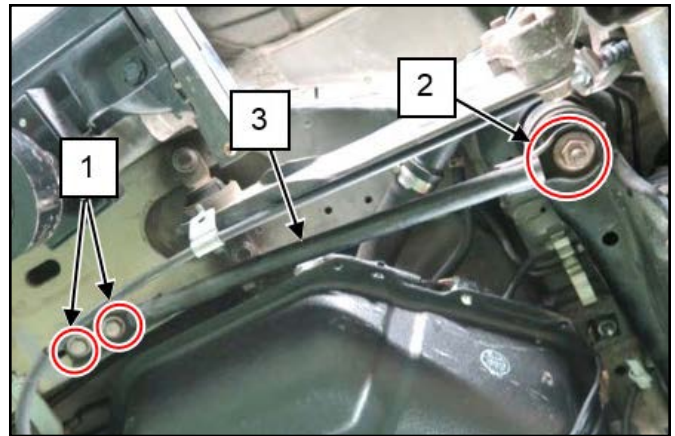

Remove and discard the left and right side trailing arm front bolts (1).

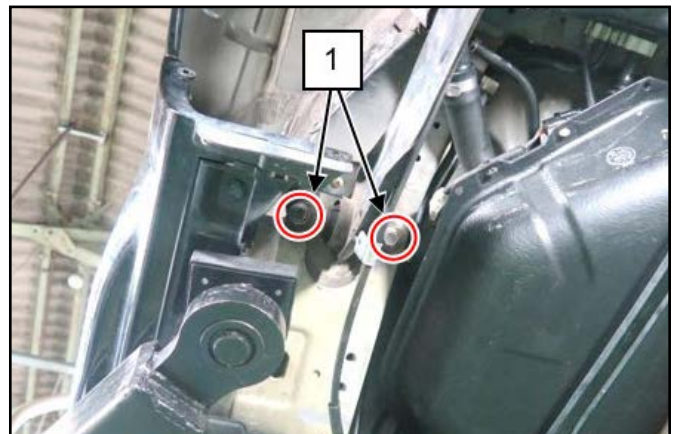

- h) Disconnect the rear wheel speed sensor connector (1).

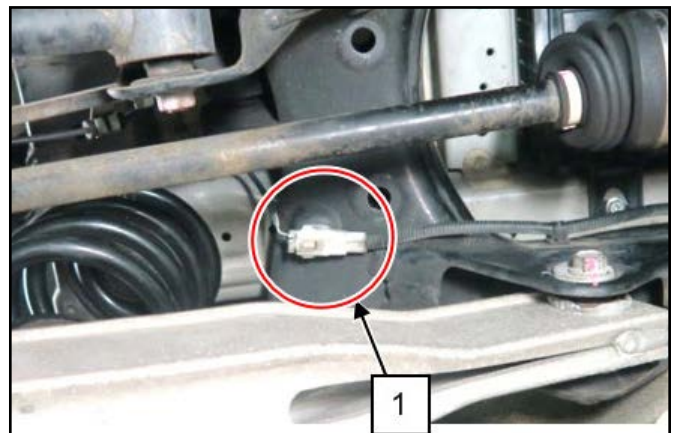

- i) Support the rear differential mounting and differential case using a lift table.

NOTE:

The rear suspension and differential will be off balance after removal. Support the differential and suspension as shown (1). Maintaining the installed orientation will aid in removal and installation of the differential and rear suspension.

- j) Remove the rear suspension frame front nuts (1) and rear suspension frame rear bolts (2), and discard them. Also remove the rear suspension frame mount washers (3).
- k) Lower the suspension frame and differential with a lift table. Remove the suspension and differential from the work area.

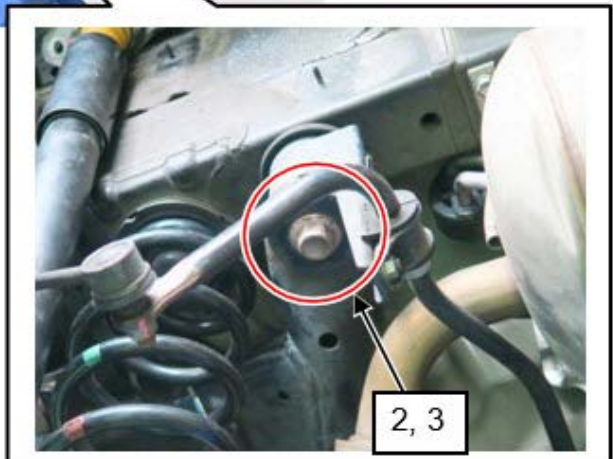
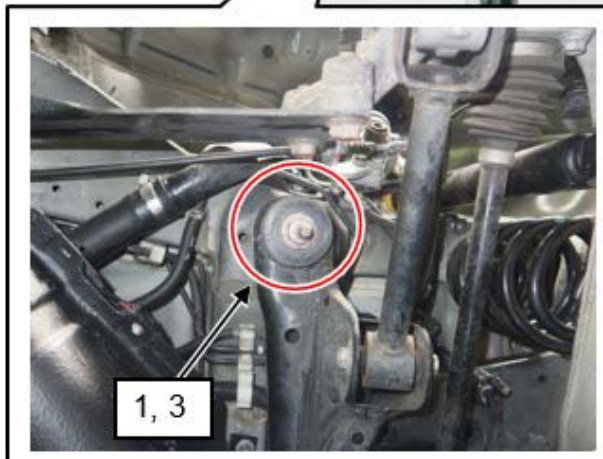
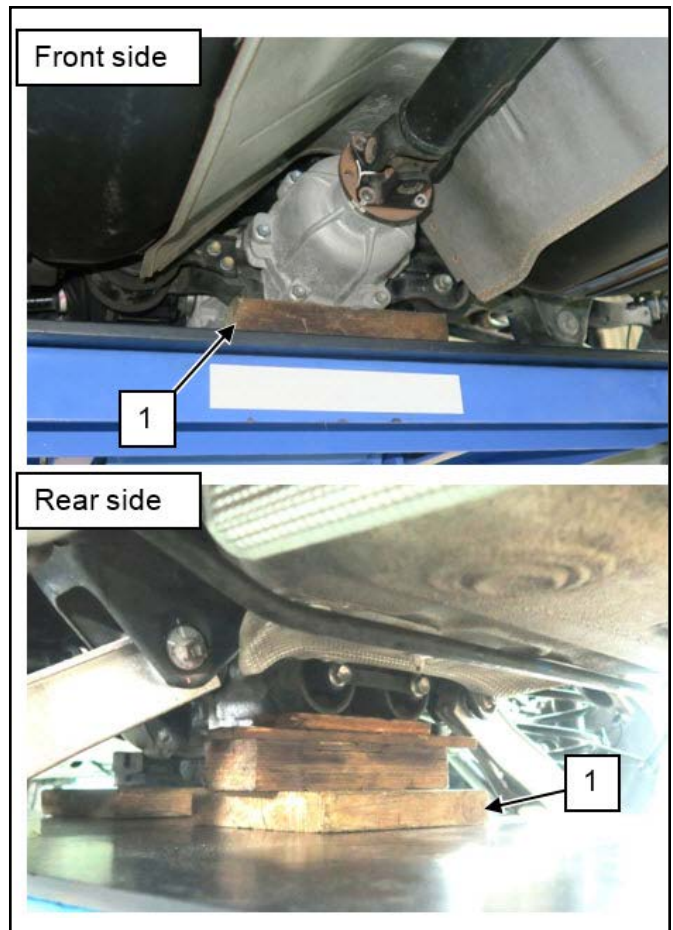

19) Remove the clamps (1) and disconnect the fuel filler hose (2) and breather hose (3).

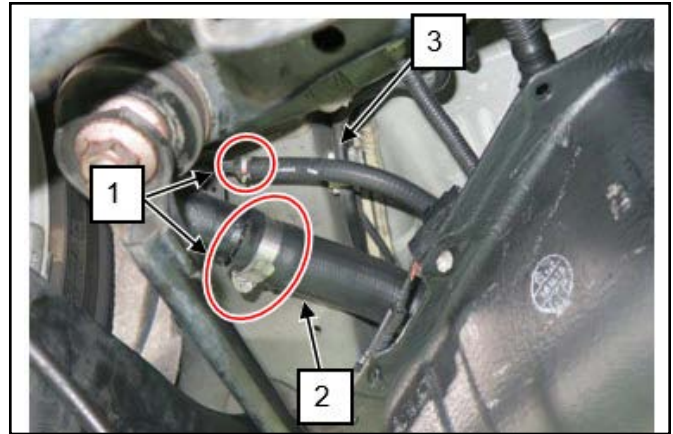

20) Disconnect the fuel tank harness connector (1).

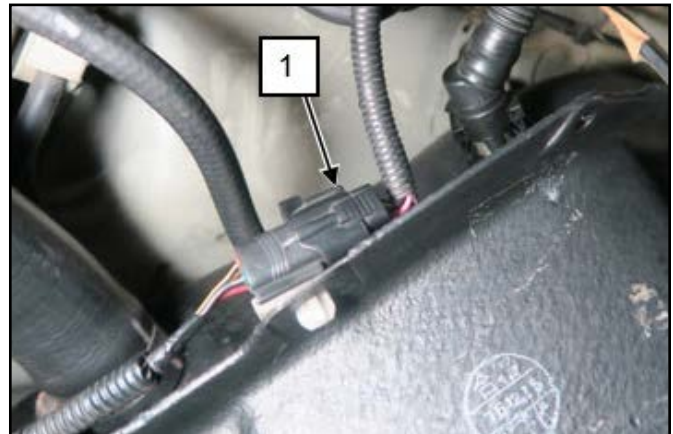

21) Disconnect the EVAP canister hose (1) from the fuel tank as follows:

- a) Depress the connector tabs (2) as shown.
- b) Disconnect the EVAP canister hose while gently wiggling it.

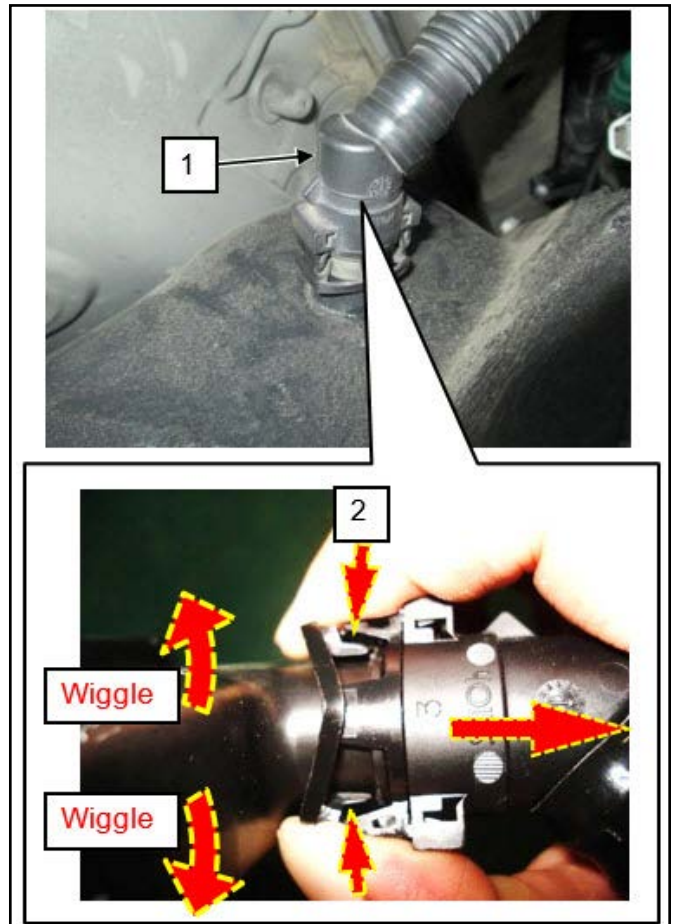

22) Disconnect the fuel feed pipe (1) as follows:

- a) Unlock the joint lock by inserting the quick joint remover between the pipe and quick joint.

**Quick Joint Remover
(A): 09919-47020**

- b) Disconnect the quick joint from the pipe.

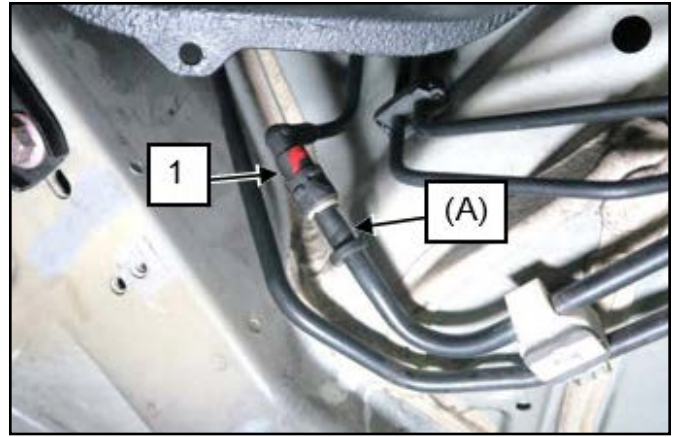

23) Support the fuel tank (1) with the transmission jack (2).

NOTE:

If using a transmission jack with a band, be sure to use the band to secure to the fuel tank to the jack to prevent the fuel tank from falling off.

24) Remove the fuel tank straps/belts (3) and the fuel tank.

NOTE:

Clean off any mud or dust from the surface of the fuel tank.

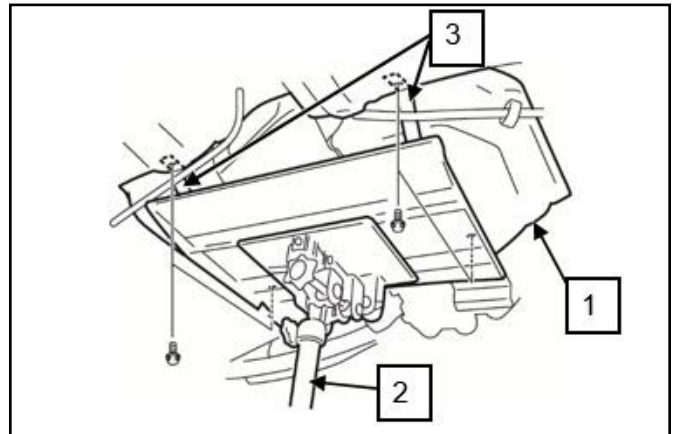

FUEL TANK DISASSEMBLY

- 1) Disconnect the fuel pump/fuel level sensor connector (2) from the fuel pump assembly (1).
- 2) Remove the fuel pump nuts (3) and ground terminal (4).

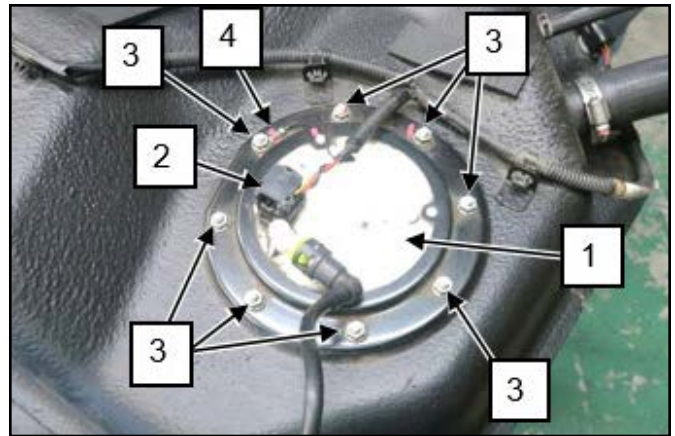

- 3) Disconnect the fuel feed pipe (1) from the fuel pump assembly as follows:
 - a) Unlock the joint lock by inserting the quick joint remover between the fuel pump assembly and quick joint.

**Quick Joint Remover
(A): 09919-47020**

- b) Disconnect the quick joint from the fuel pump assembly.

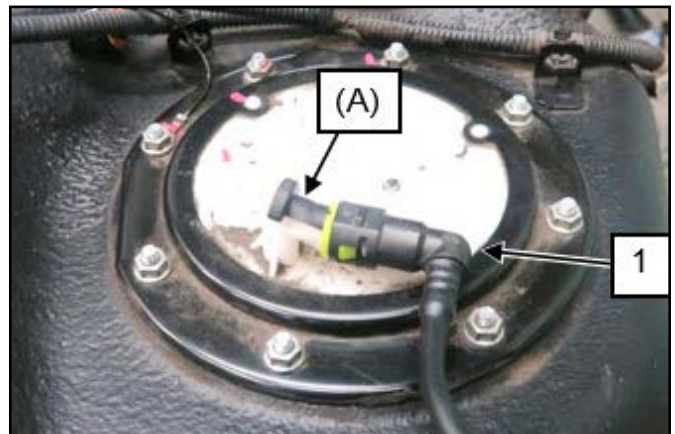

- 4) For AWD models, lift up the fuel pump and disconnect the fuel suction pipe (1) from the fuel pump assembly.
- 5) Remove the fuel pump assembly from the fuel tank.

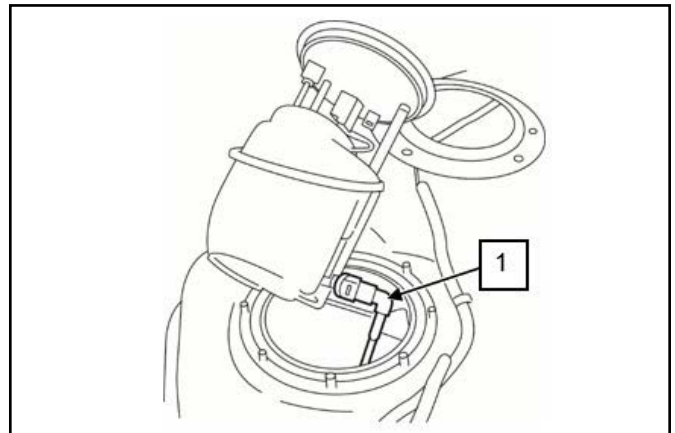

- 6) Remove and discard the fuel pump gasket (1).

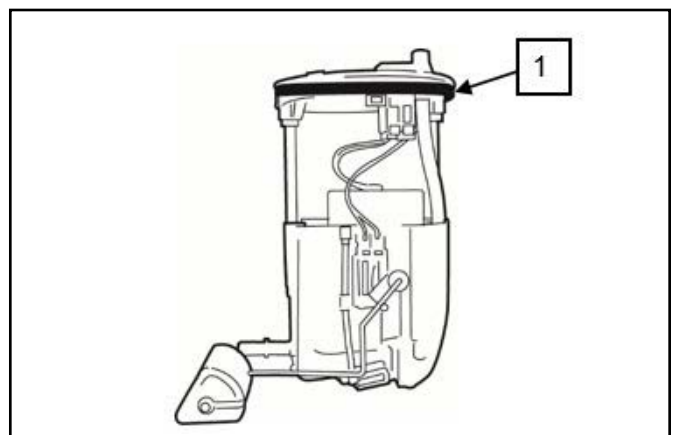

7) For AWD models, remove the sub fuel level sensor from the fuel tank as follows:

- a) Disconnect the sub fuel level sensor connector (1).
- b) Remove the screws (2) and sub fuel level sensor (3).

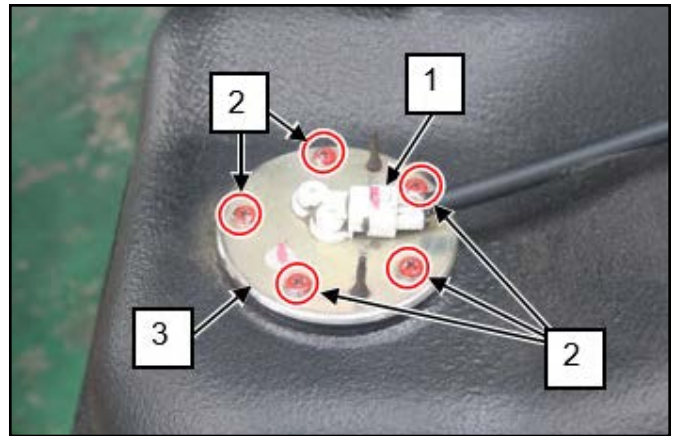

- c) Remove and discard the sub fuel level sensor gasket (1).

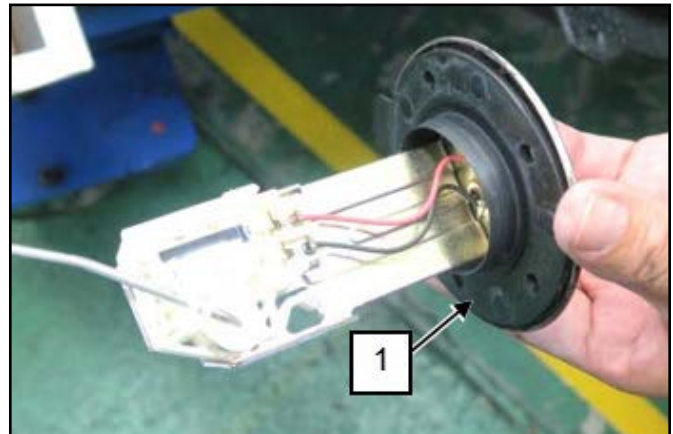

8) For AWD models, remove the fuel suction pipe (1) from the interior of the fuel tank as follows:

- a) Unlock the joint lock by insert the quick joint remover between the fuel pipe and quick joint.

**Quick Joint Remover
(A): 09919-47020**

- b) Disconnect the quick joint from the fuel pipe.

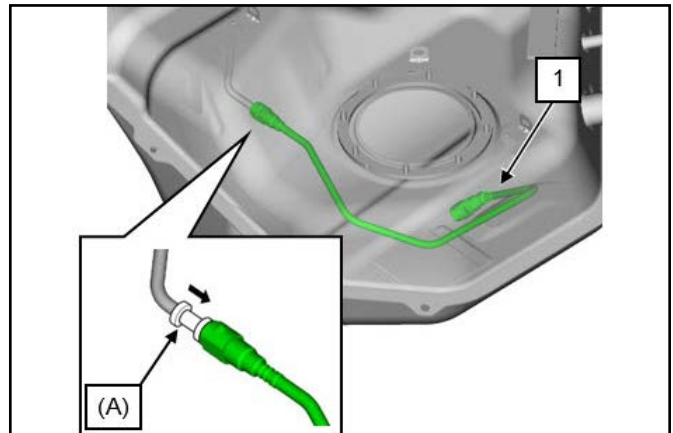

9) Remove the fuel filler hose (1).



10) Detach the clamp (1) and remove the breather hose (2).

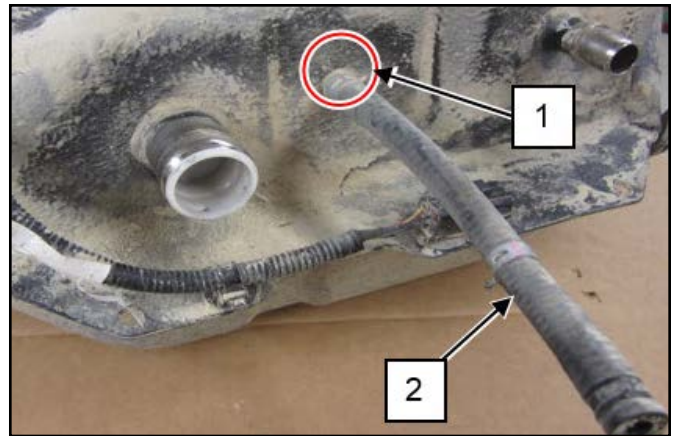

11) Detach the clamps (1) and remove the wire harness (2).

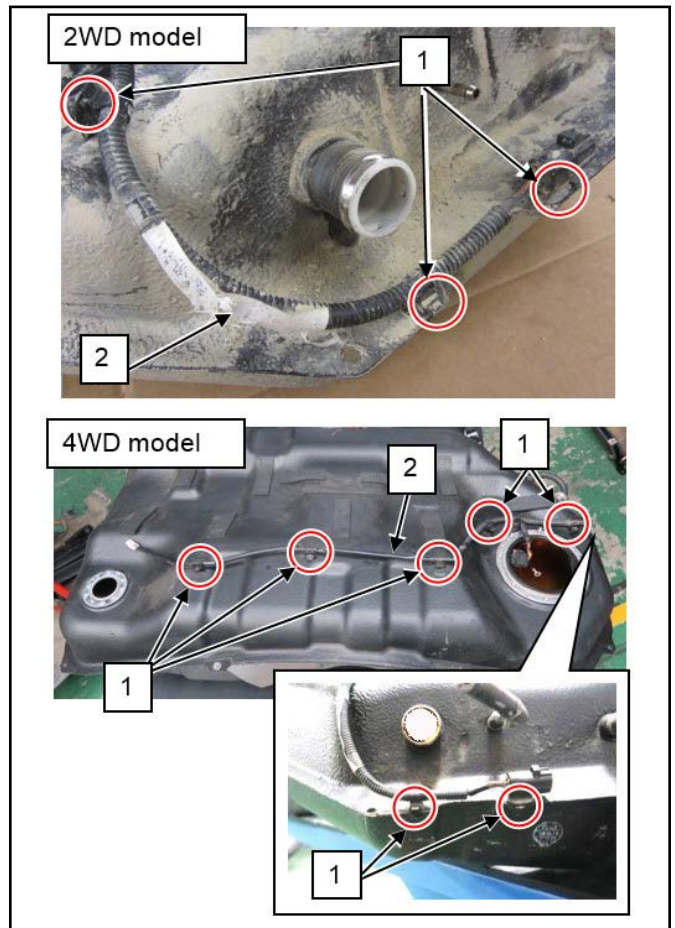

12) Remove the bolts (1) and fuel tank protector.

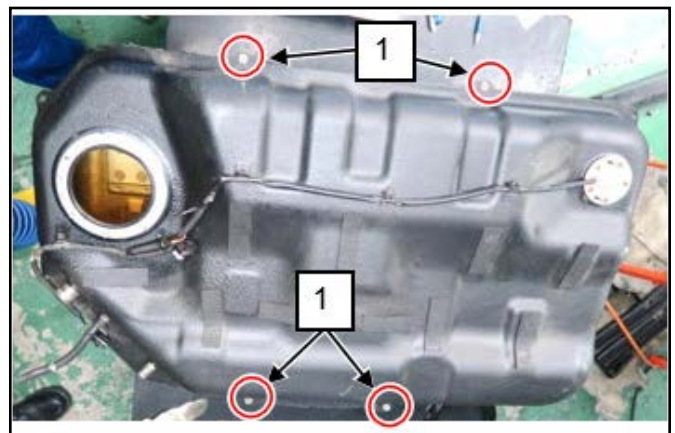

- 13) Note the specific location and then remove the fuel tank flange protectors (1). There are two flange protectors on the AWD fuel tank and three on the FWD fuel tank. The protectors are located at the intersection of the fuel tank retaining straps and the fuel tank flange.

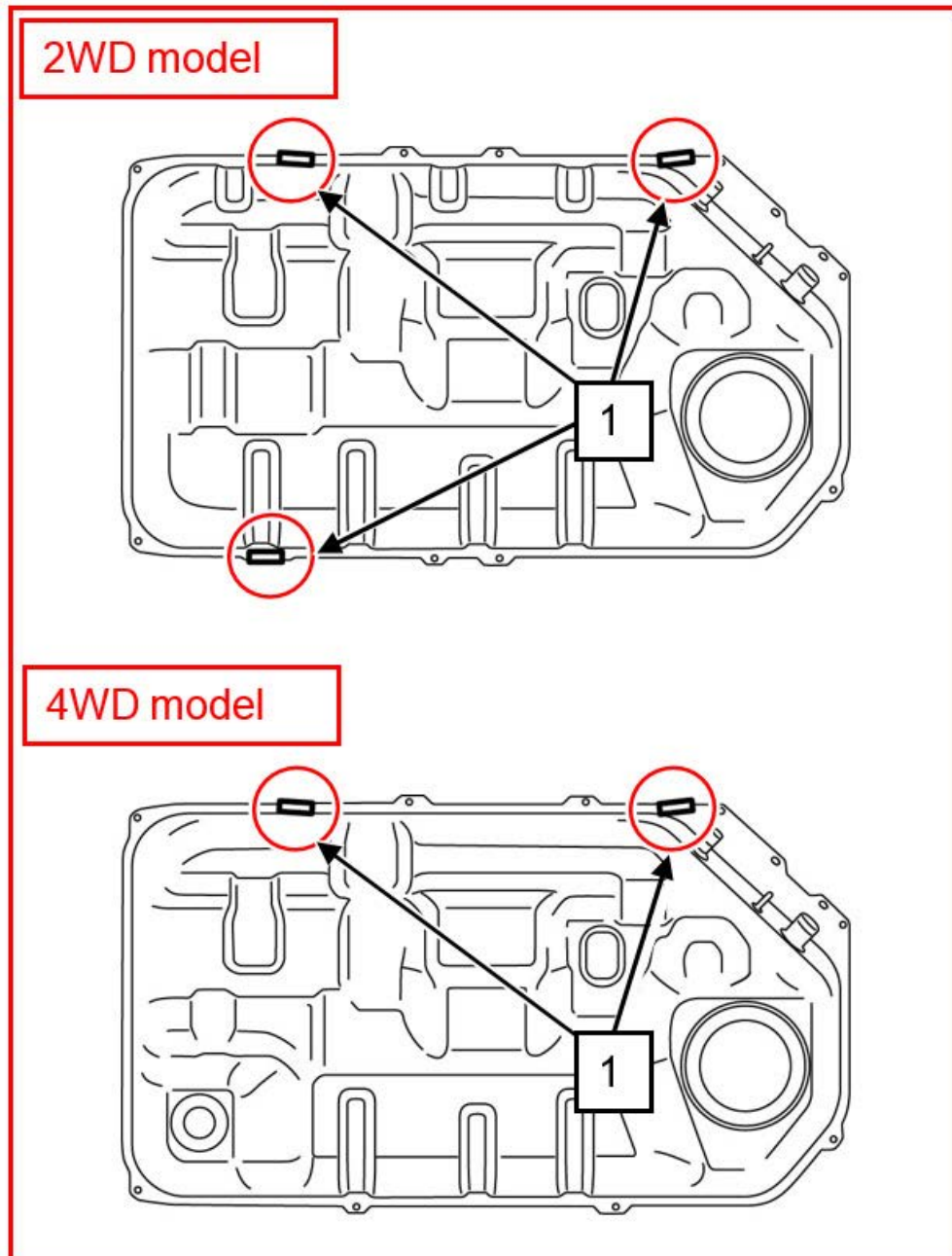

FUEL TANK REASSEMBLY

WARNING

Failure to take proper precautions when reinstalling the fuel tank connections can result in fuel leaks or damage.

Clean the outside surface of the pipe where each quick joint is to be installed, push the pipe into the joint until the joint clicks, and check that the pipe is connected securely.

- 1) Install the fuel tank flange protectors (1) removed in step 13 of the previous page.

There are two flange protectors on the AWD fuel tank, and three flange protectors on the FWD fuel tank.

(For larger images, see the previous page.)

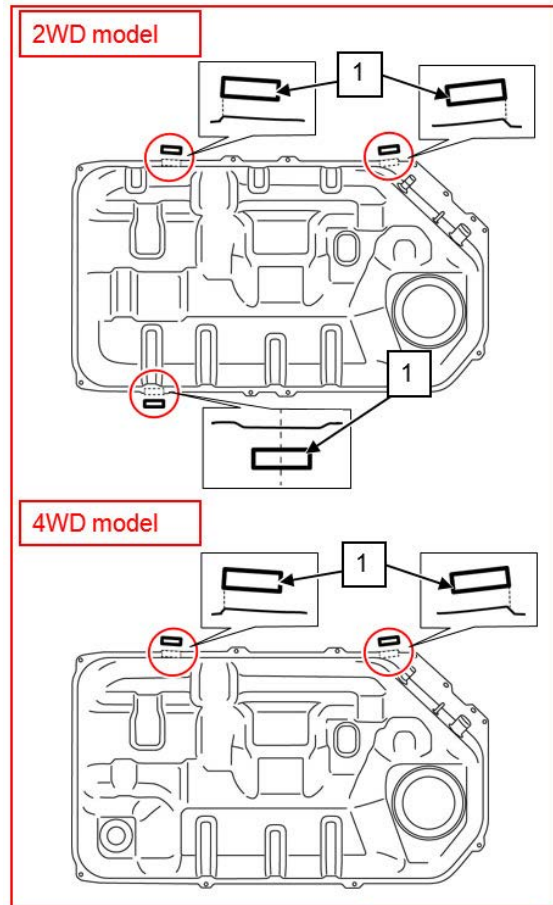

- 2) Install the fuel tank protector onto the counter-measure fuel tank.
- 3) Tighten fuel tank protector bolts (1) to the specified torque.

Tightening torque

Fuel tank protector bolt (a):
5.5 N·m (.56 kgf-m, 4.0 lbf-ft)

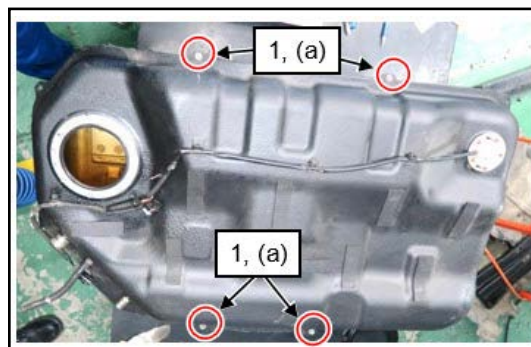

- 4) Install the wire harness (1) and attach the clamps (2).

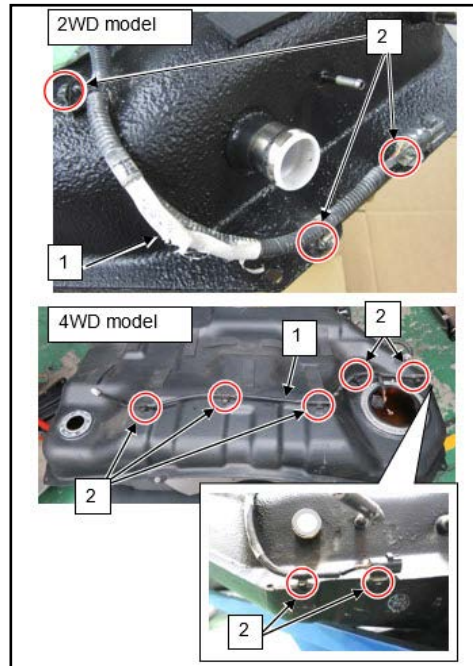

- 5) Connect the breather hose (1) and secure it with a clamp as shown.

"a": 3 - 7 mm (0.12 - 0.27 in)

"b": 0 - 2 mm (0.00 - 0.08 in)

"c": 45 degrees

"d": Vehicle passenger side

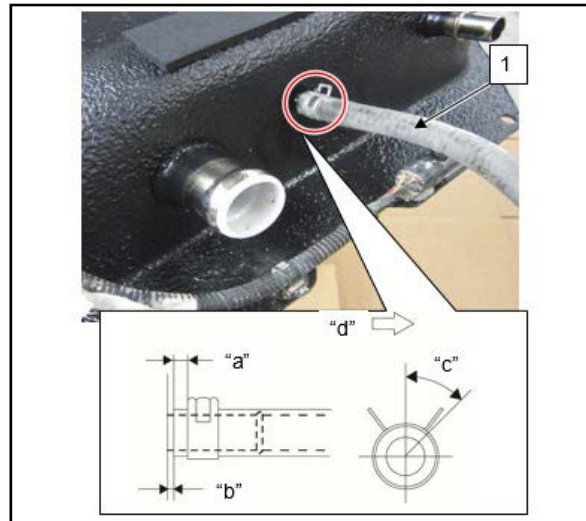

NOTE:

Be sure the roll-over/inlet valve is present prior to installing the fuel filler hose.

- 6) Connect the filler hose (1) and secure it with a clamp (2) as shown.

a: 7 - 14 mm (0.27 - 0.55 in)

b: 0 - 2 mm (0.00 - 0.08 in)

c: 45 degrees

d: Vehicle driver side

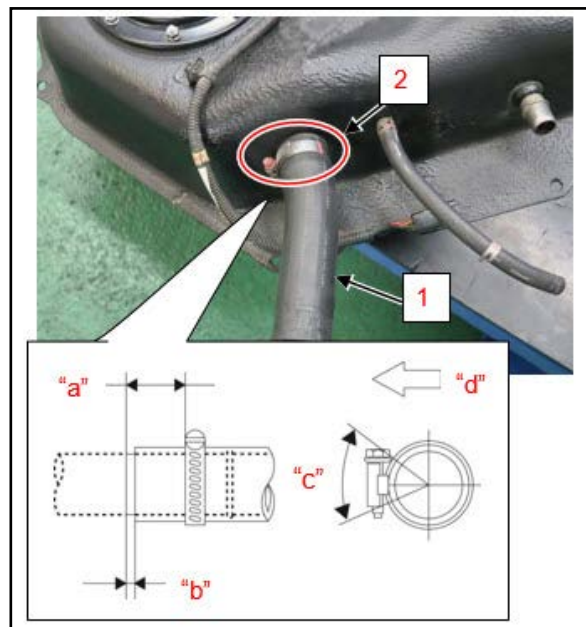

- 7) For AWD models, connect the fuel suction pipe (1) to the fuel tank interior.

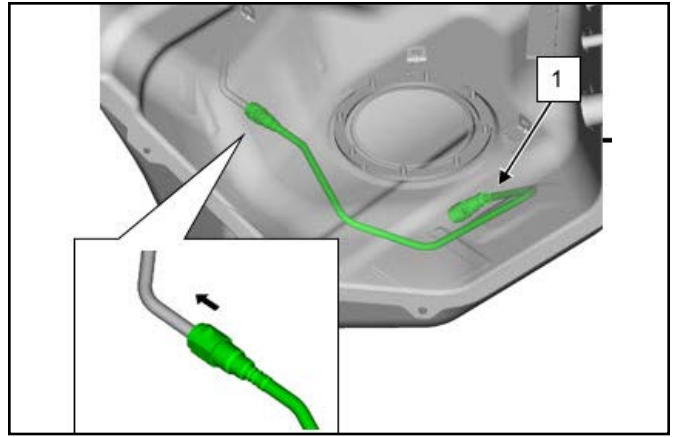

- 8) For AWD models, install the sub fuel level sensor as follows:

- a) Install a new sub fuel level sensor gasket (1).

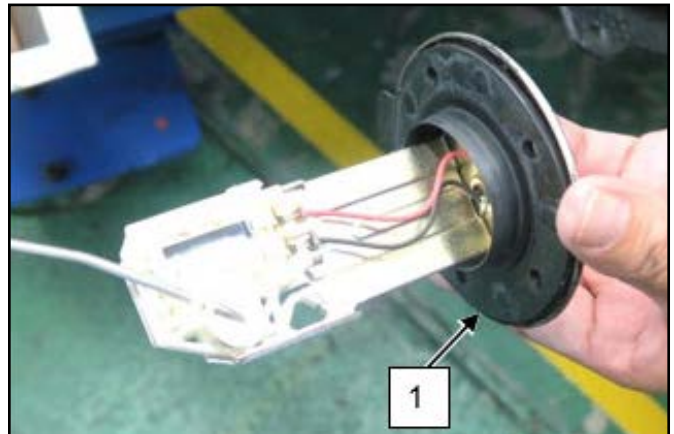

- b) Install the screws (1) of the sub fuel level sensor (2) onto the fuel tank, and tighten them to the specified torque.

Tightening torque

**Sub fuel level sensor screw:
1.6 N·m (0.16 kgf-m, 1.5 lbf-ft)**

- c) Connect the sub fuel level sensor connector (3).

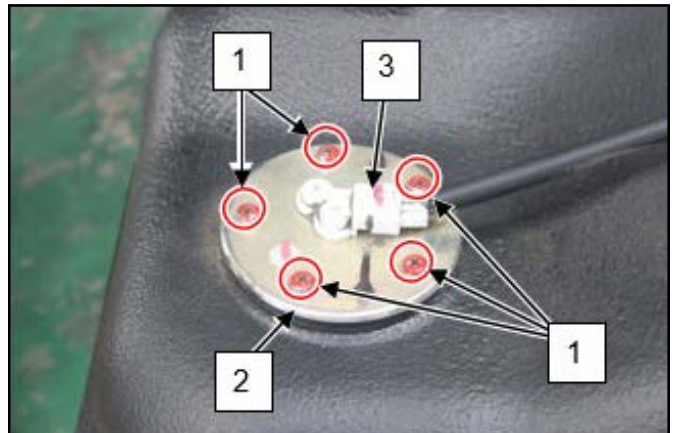

- 9) Install the new fuel pump gasket (1).

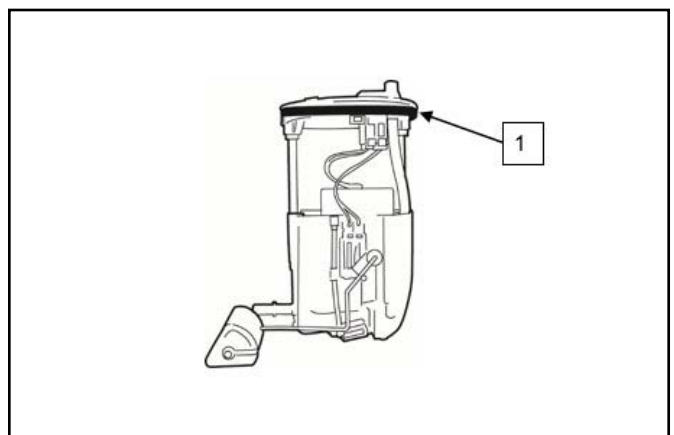

- 10) For AWD models, connect the fuel suction pipe (1) to the fuel pump assembly.

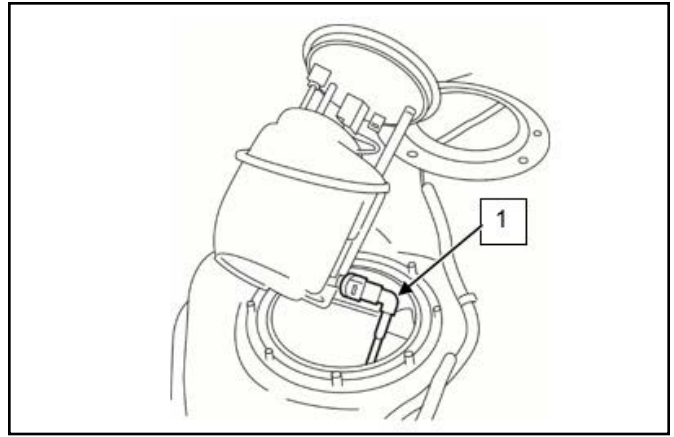

- 11) Align the protrusions (1) of the fuel pump with the aligning hole (2) on the fuel pump plate.

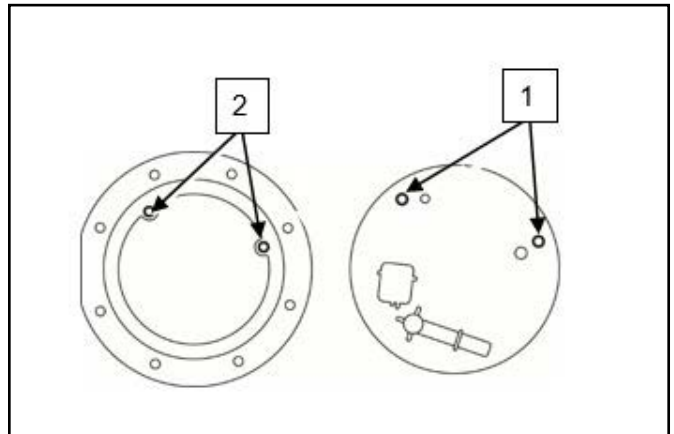

- 12) Install the fuel pump (1) and ground terminal (2).
13) Tighten the fuel pump nuts (3) to the specified torque.

Tightening torque

Fuel pump nut (a):

10 N·m (1.0 kgf-m, 7.5 lbf-ft)

- 14) Connect the fuel feed pipe (4) from the fuel pump assembly.
15) Connect the fuel pump/fuel level sensor connector (5) from the fuel pump assembly.

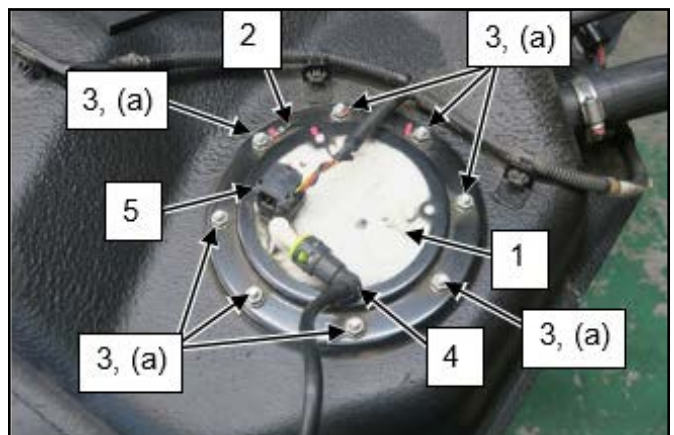

REPLACEMENT OF THE CANISTER AIR SUCTION FILTER AND VENT PIPE

NOTICE

If the EVAP leak check module is removed from the EVAP canister, the module mounting position of the EVAP canister may be damaged.

Do not remove the EVAP leak check module from the EVAP canister.

Many of the views in this section are of the FWD model, the AWD model views are similar.

REMOVAL

- 1) Remove the left rear wheel if not previously removed.
- 2) Remove the left rear fender wheel house lining if not previously removed.

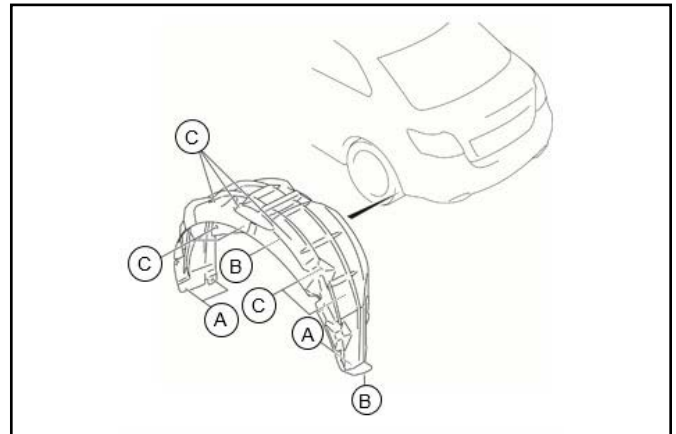

NOTE:

The rear fender lining is secured with three types of clips. To remove them, refer to the illustration.

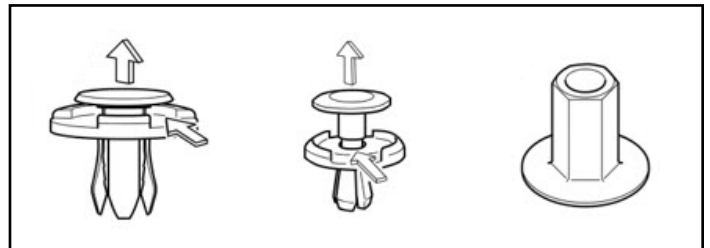

- 3) Remove the cap tether clip (1).
- 4) Remove the fuel filler cap (2).
- 5) Remove the fuel filler neck No. 1 bolts (3).

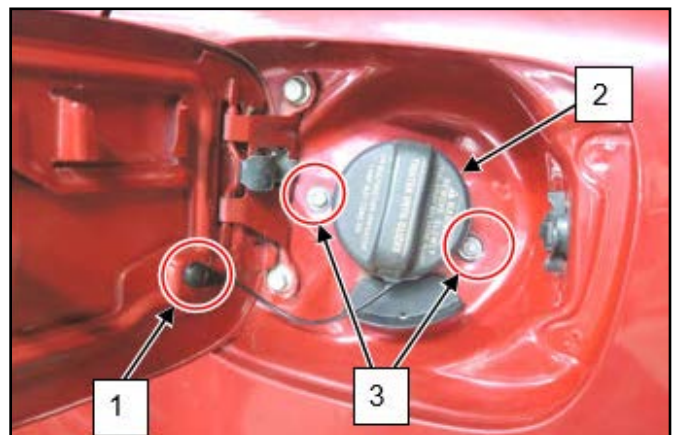

- 6) Remove the fuel filler neck bolt No. 2 (1) and fuel filler neck (2).
- 7) Remove the filter outlet pipe (3) from the clamps (4).

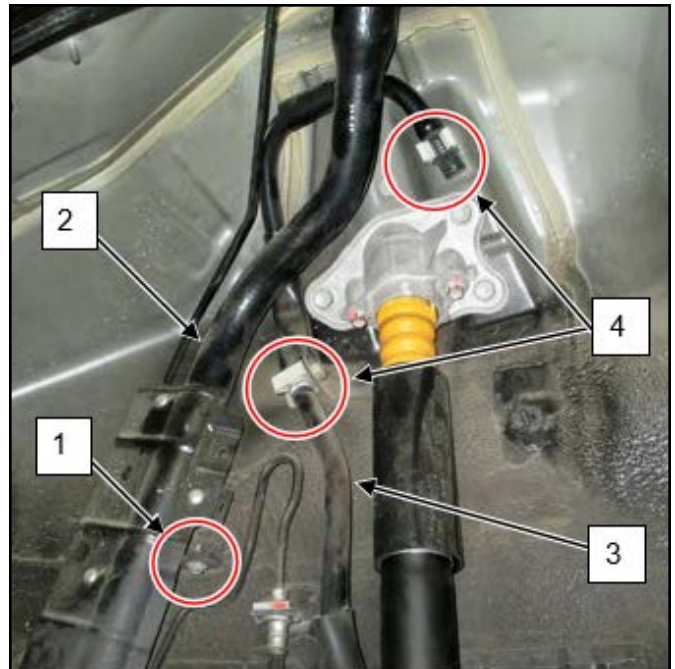

- 8) Remove the canister suction filter bolts (1).

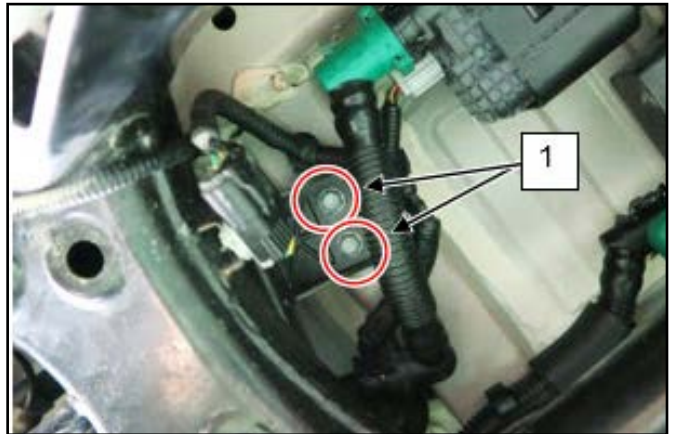

- 9) Disconnect the suction pipe (1) from the EVAP canister (2) as follows:

- a) Depress the end of the connector tabs (3).
- b) Disconnect the connector while lightly wiggling the suction pipe.

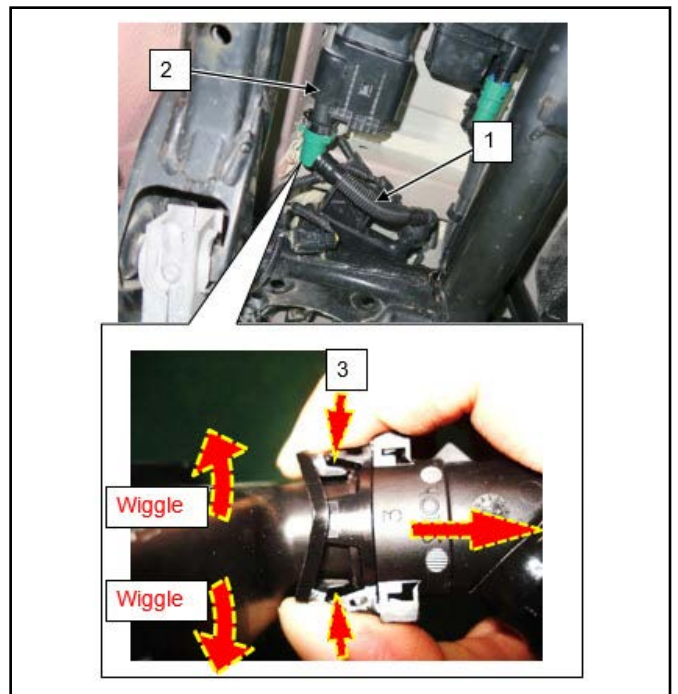

- 10) With the filter outlet pipe connected, pull out the canister filter and suction pipe from the vehicle (1).

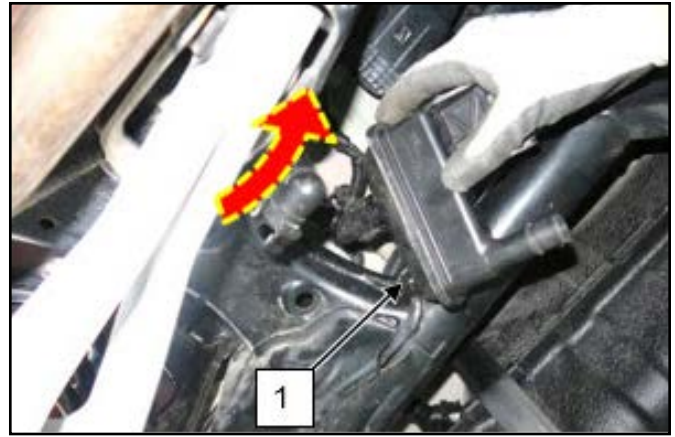

INSTALLATION

- 1) Install the new suction pipe (1) as shown.

NOTE:

If the vehicle undercarriage is dirty or contains debris, cover the canister suction hose opening prior to routing it back into the vehicle.

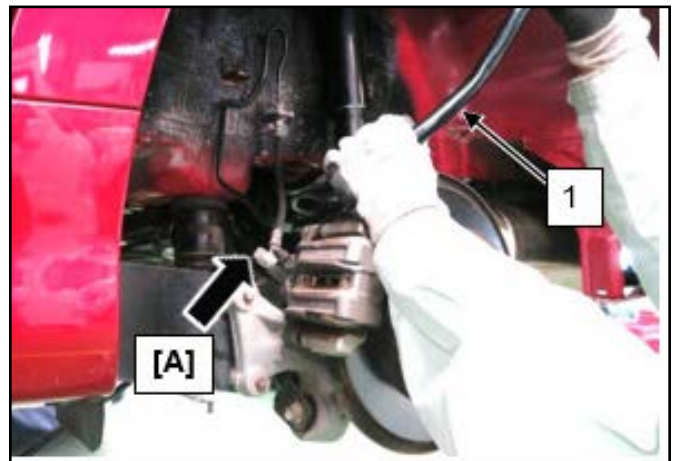

- 2) Install the suction pipe (1) onto the clamp (2).

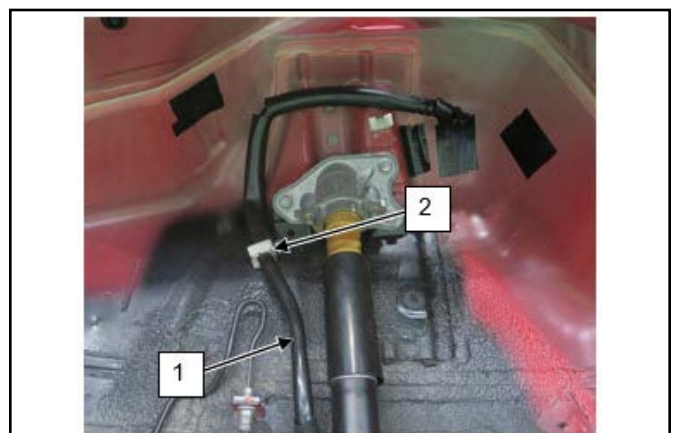

- 3) Install the fuel filler neck (1) and tighten the fuel filler neck bolt No. 2 (2) to the specified torque.

Tightening torque

Fuel filler neck bolt No. 2 (a):
5.5 N·m (0.56 kgf-m, 4.0 lbf-ft)

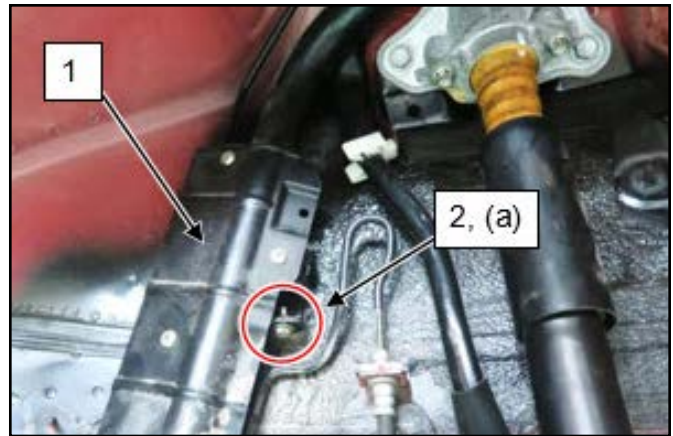

- 4) Tighten the fuel filler neck No. 1 bolts (1) to the specified torque.

Tightening torque

Fuel filler neck bolt No. 1 (a):
3.0 N·m (0.31 kgf-m, 2.5 lbf-ft)

- 5) Install the new fuel filler cap (2).
6) Install the tether clip (3).

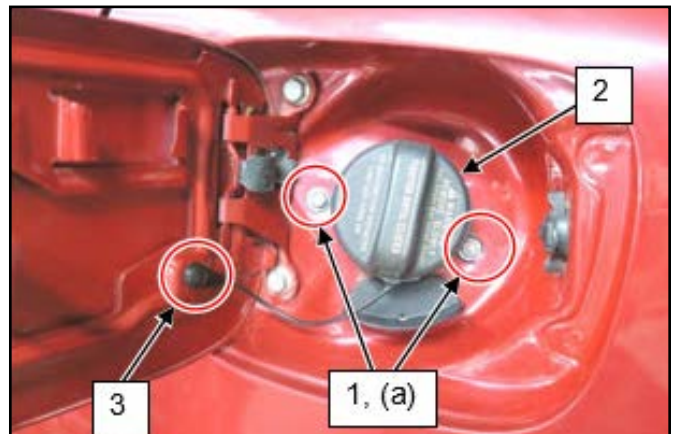

- 7) Install the new air suction cap (1) onto the new canister suction filler (2).



- 8) Install the new suction filler No. 2 bracket (1) onto the canister suction filter and tighten the new filter bracket bolts (2) to the specified torque.

Tightening torque

Filter bracket bolts (a):
10 N·m (1.0 kgf-m, 7.5 lbf-ft)

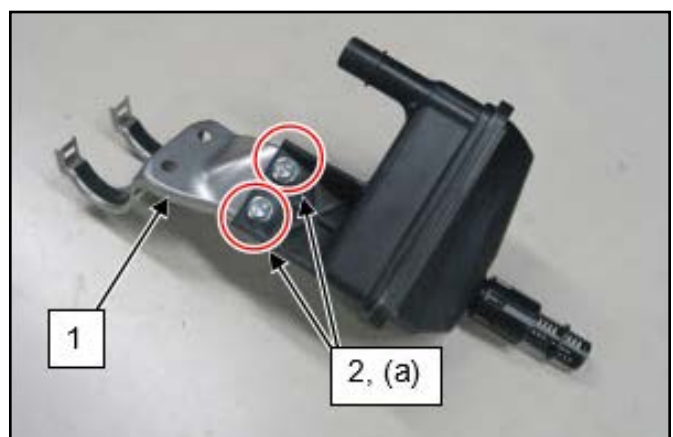

- 9) Align the notch of the new suction filter No. 1 bracket (1) with the bolt (2), and temporarily install the suction filter No. 1 bracket onto the fuel filler neck (3) and loosely install the new nut provided to retain the No. 1 bracket.



- 10) Hook the suction filter No. 1 bracket (1) into the new suction filter attached to the suction filter No. 2 bracket holes (2).

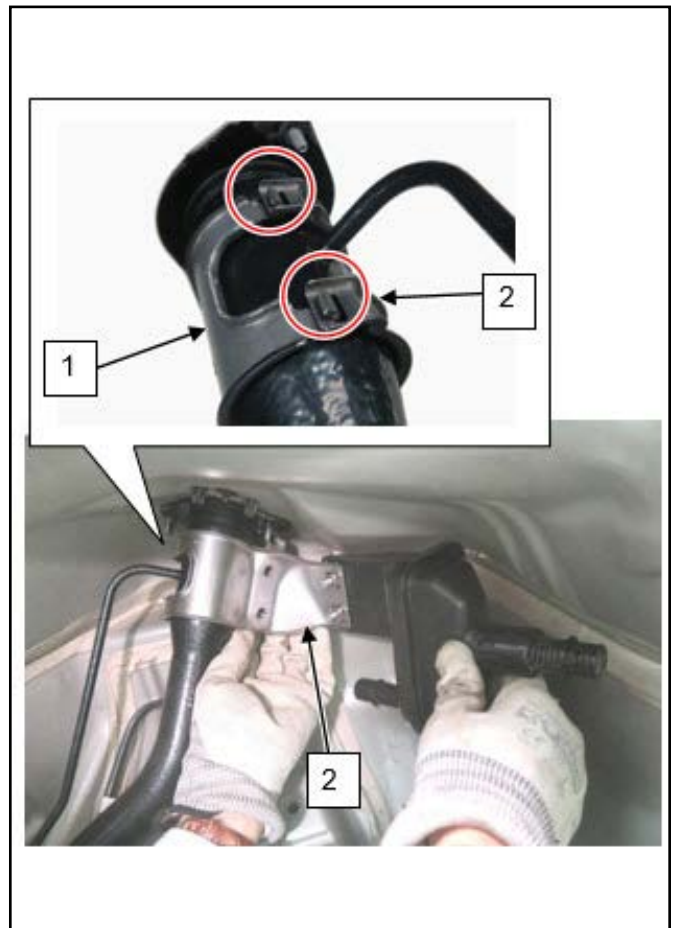

- 11) Tighten the new filter bracket bolts (1) to the specified torque.

Tightening torque

Filter bracket bolt (a):

10 N·m (1.0 kgf-m, 7.5 lbf-ft)

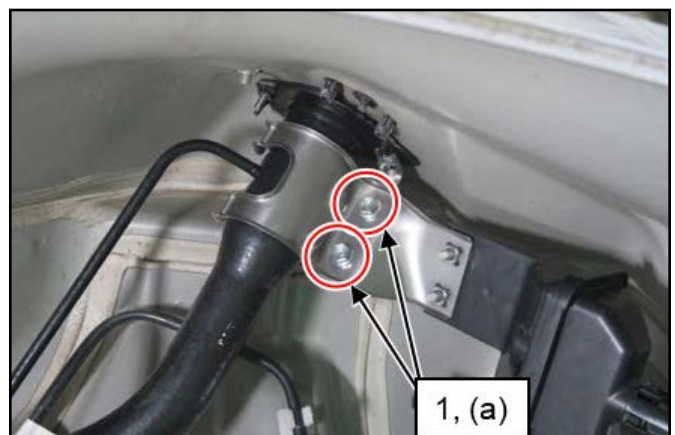

- 12) Tighten the new filter bracket nut (1) to the specified torque.

Tightening torque

Filter bracket nut (a):

3.0 N·m (0.31 kgf-m, 2.5 lbf-ft)



- 13) Connect the suction pipe (1) to the canister suction filter (2). Push the suction pipe until you can hear it click.

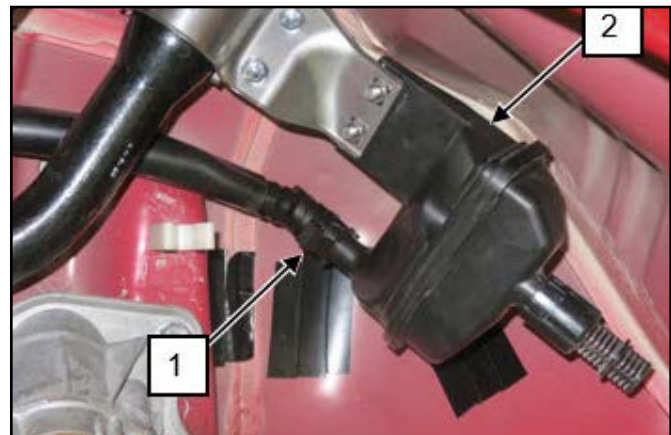

INSPECTION OF THE CANISTER SUCTION FILTER FOR EVAP CANISTER / EVAP LEAK CHECK MODULE REPAIR

INSPECTION

- 1) Check the condition of the canister suction filter (1) as follows:
 - a) Remove any mud or dust from the canister filter exterior.
 - b) Weight the canister filter; based on the weight of the filter, do the following:

Canister suction filter is more than 154 g (5.43 oz)	Canister suction filter is less than 154 g (5.43 oz)
Proceed to Replacement of the EVAP Canister / EVAP Leak Check Module Assembly	Proceed to Installation of Countermeasure Fuel Tank



REPLACEMENT OF THE EVAP CANISTER / EVAP LEAK CHECK MODULE ASSEMBLY

REMOVAL

- 1) Disconnect the EVAP canister hose (1) as follows:
 - a) Depress the end of the connector tabs (2) as shown
 - b) Disconnect the EVAP canister hose while lightly shaking the EVAP canister hose.

- 2) Disconnect the purge pipe (3) from the EVAP canister as follows:
 - a) Remove any mud or rust around the joint by blowing compressed air on it, then release the joint lock by fully pushing the joint in the direction of the arrow.
 - b) Disconnect the pipe joint while the joint lock is being released.

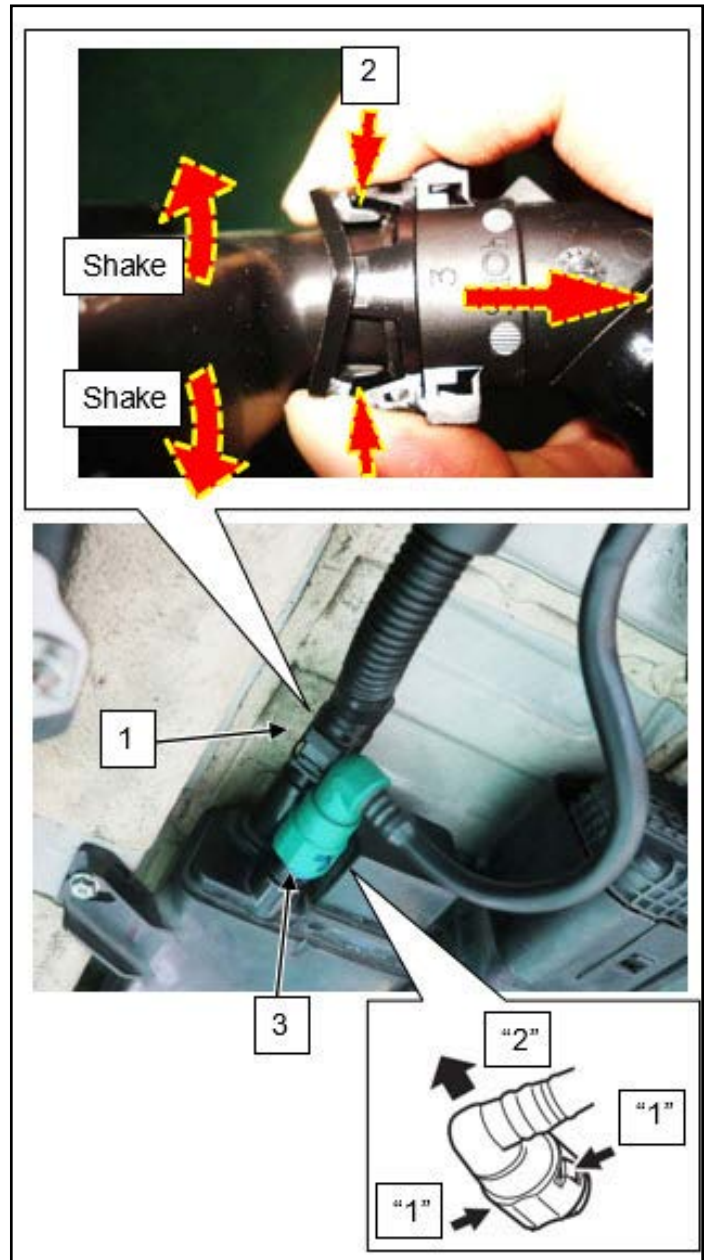

- 3) Disconnect the EVAP leak check module connector (5).
- 4) Remove the bolts (6) and EVAP canister / EVAP leak check module (7) as an assembly.

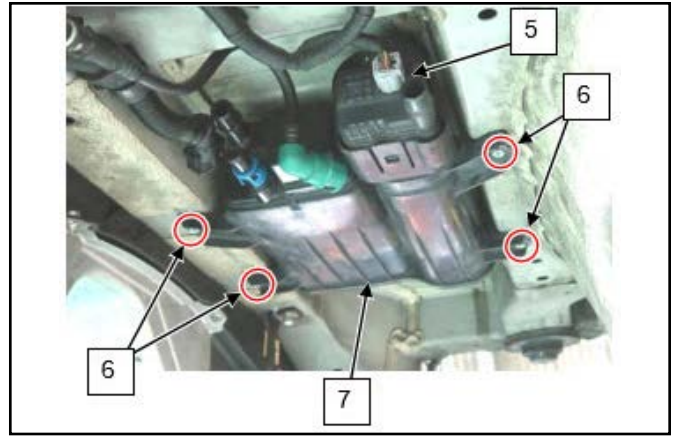

INSTALLATION

- 1) Clean the inside of the quick joint and the outside of the pipe.
- 2) Install the new EVAP canister (1) and tighten the EVAP canister bolts (2) to specified torque.

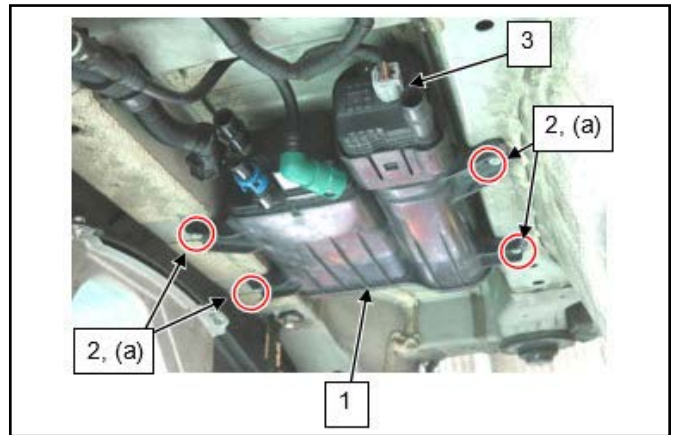

Tightening torque

EVAP canister bolt (a):

10 N·m (1.0 kgf-m, 7.5 lbf-ft)

- 3) Connect EVAP leak check module connector (3).
- 4) Connect the EVAP canister hose (1).

NOTE:

Push the joint into the pipe until the joint lock clicks. Then check that the quick joint is secure and does not disengage by pulling on the quick joint in the direction of the arrow as shown.

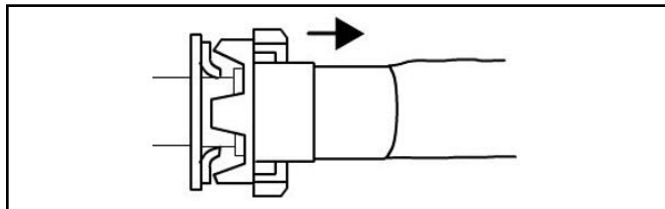

- 5) Connect the purge pipe (2) as shown.

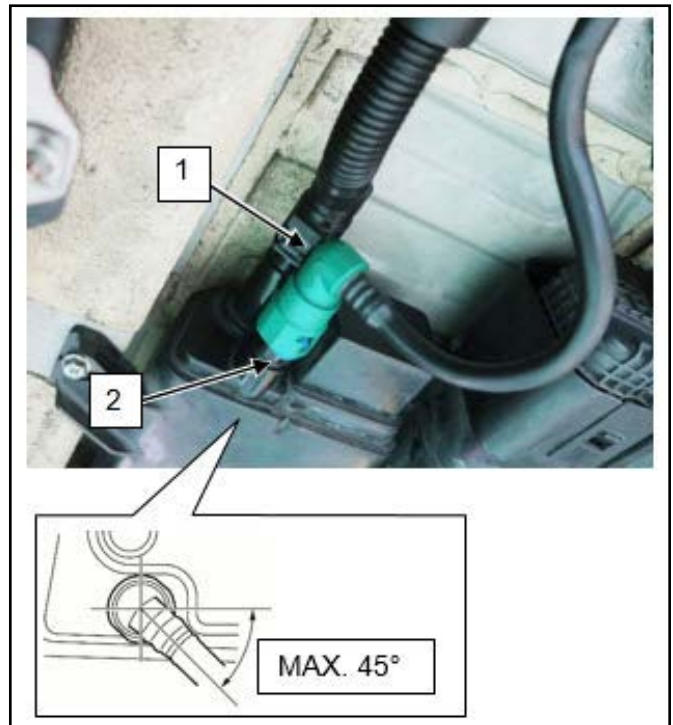

INSTALLATION OF THE COUNTERMEASURE FUEL TANK

⚠ WARNING

Failure to take proper precautions when reinstalling the fuel tank connections can result in fuel leaks or damage.

Clean the outside surface of the pipe where each quick joint is to be installed, push the pipe into the joint until the joint clicks, and check that the pipe is connected securely.

- 1) Connect the suction pipe (1) to the EVAP canister (2).



- 2) Install the fuel tank belts/straps (1).
- 3) Lift the fuel tank with a jack and install the countermeasure fuel tank.
- 4) Tighten the new fuel tank belt/straps bolts (2) to specified torque.

Tightening torque

Fuel tank belt bolt (a):

45 N·m (4.6 kgf-m, 33.5 lbf-ft)

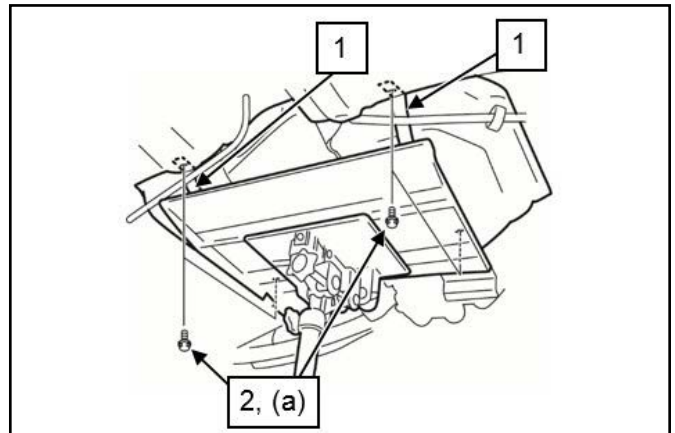

- 5) Connect the fuel feed pipe (fuel pump side) (1) to the fuel feed pipe (body side) (2), and clamp them securely.

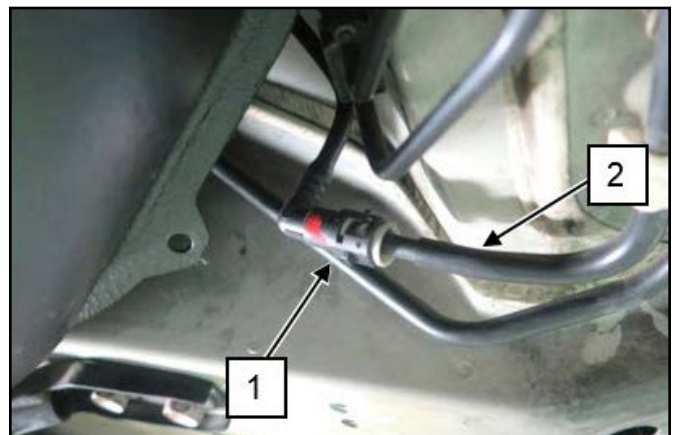

- 6) Connect the EVAP canister hose (1) and push down firmly until you hear a snap.



- 7) Install the fuel filler hose (1) and breather hose (2), and secure them with clamps as shown.

- a: 3 – 7 mm (0.12 – 0.27 in)
- b: 45 degrees
- c: 9 – 16 mm (0.36 – 0.62 in)
- d: 4 mm (0.16 in)
- e: Vehicle backward
- f: Vehicle leftward

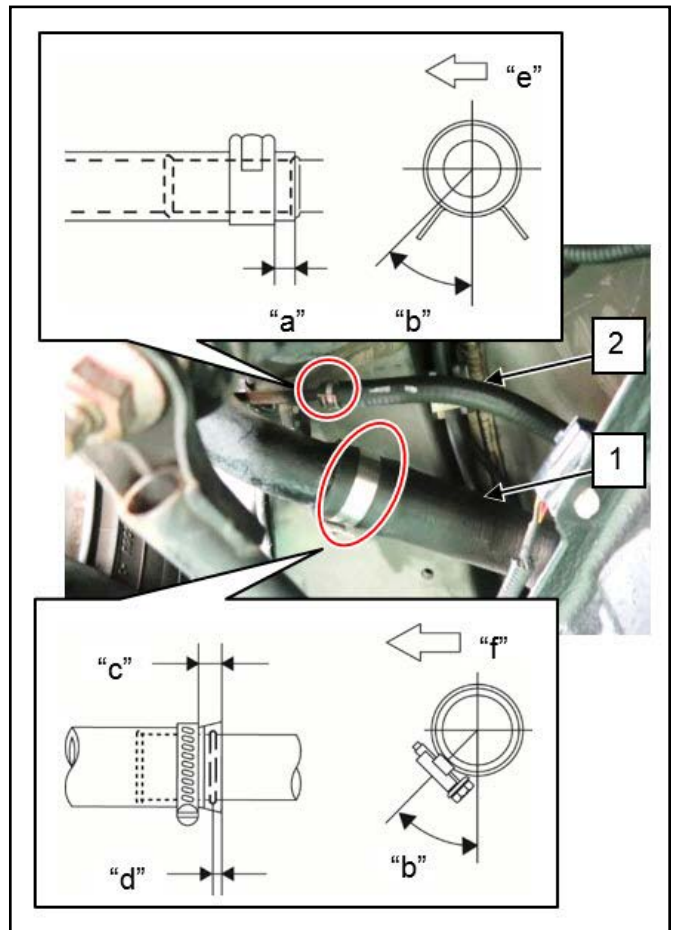

- 8) Connect the fuel tank harness connector (1).

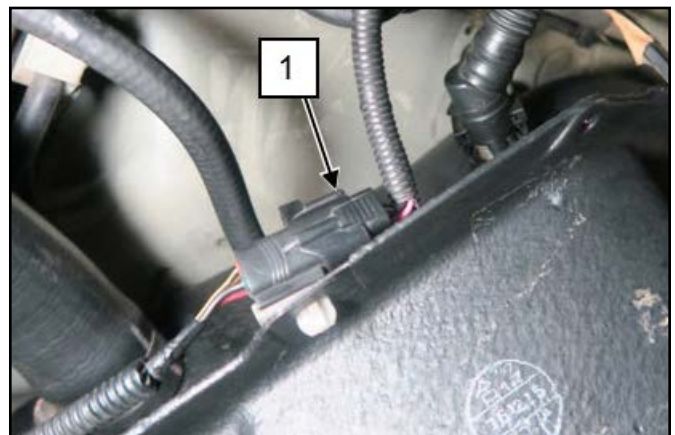

MISCELLANEOUS PARTS ASSEMBLY

- 1) Remove the screw (1) and the old rear wheel house liner front cap (2) as shown.



- 2) Install the new left wheel house lining front cover (1) as shown.



- 3) Install the new screw (1) and new clip (2).



Install the parking brake cable clamp to the vehicle body and tighten the parking brake cable clamp bolts to the specified torque.

Tightening torque

Parking brake cable bolt (a):
11 N·m (1.1 kgf-m, 8.5 lbf-ft)

Parking brake cable bolt (b):
25 N·m (2.5 kgf-m, 18.5 lbf-ft)

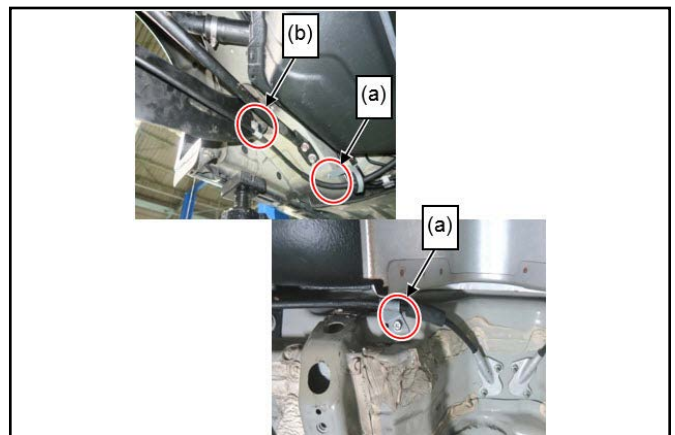

For FWD models, proceed to Step 6

For AWD models, proceed to Step 5

- 4) Install the rear suspension frame and differential as follows:
- a) Lift up the rear suspension frame and differential using the lift table.
 - b) Temporarily hand-tighten the new rear suspension frame front nuts (1) and new rear suspension frame rear bolts (2) via rear suspension frame mounting washer (3).
 - c) Tighten the rear suspension frame front nuts and rear suspension frame rear bolts to specified torque

Tightening torque

Rear suspension frame front nut (a):
110 N·m (11.2 kgf-m, 81.5 lbf-ft)

Rear suspension frame rear bolt (b):
110 N·m (11.2 kgf-m, 81.5 lbf-ft)

NOTICE

The rear suspension frame front nut and rear suspension frame rear bolt are pre-coated with friction stabilizer. If these bolts are reused, they may work loose.

Never reuse the rear suspension frame front nut and rear suspension frame rear bolt.

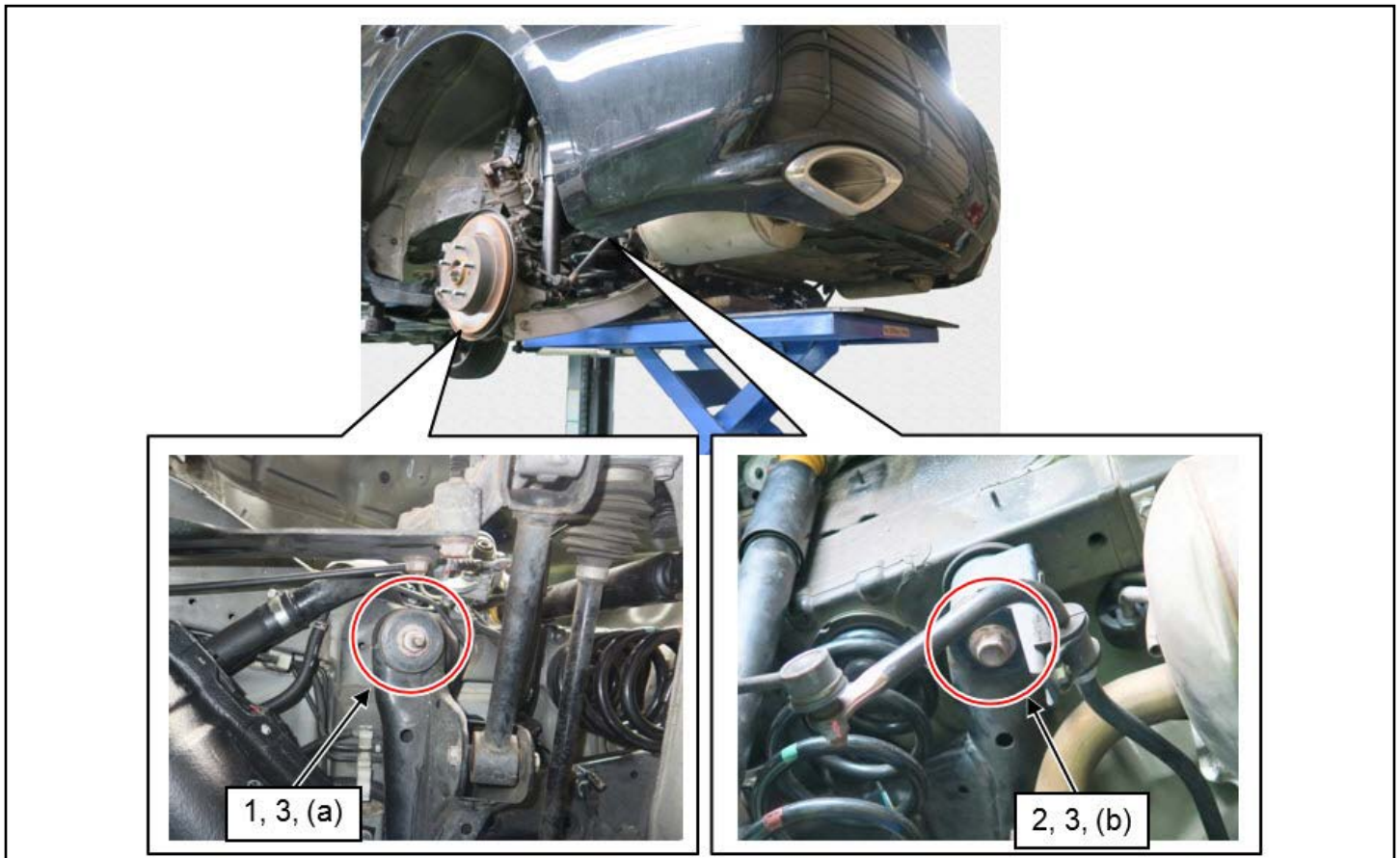

- d) Connect the rear wheel speed sensor connector (1).
- e) Install frame the front bar (1) and temporarily tighten the new frame front bar front bolts (2) and new frame front bar rear nut (3).

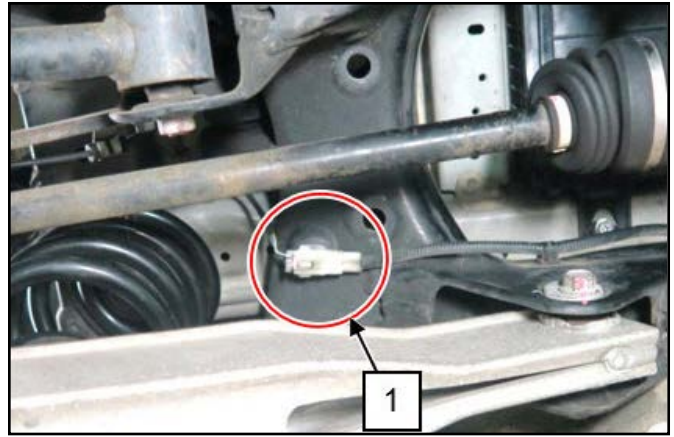

NOTICE

The frame front bar front bolt and frame front bar rear nut are pre-coated with friction stabilizer. If these bolts are reused, they may work loose.

Never reuse the frame front bar front bolt and frame front bar rear nut.

- f) Tighten the new frame front bar front bolts and frame front bar rear nuts to specified torque.

Tightening torque

**Frame front bar front bolt (a):
65 N·m (6.6 kgf-m, 48.0 lbf-ft)**

**Frame front bar rear nut (b):
110 N·m (11.2 kgf-m, 81.5 lbf-ft)**

- g) Install the trailing arm and temporarily tighten the new trailing arm front bolts (1).

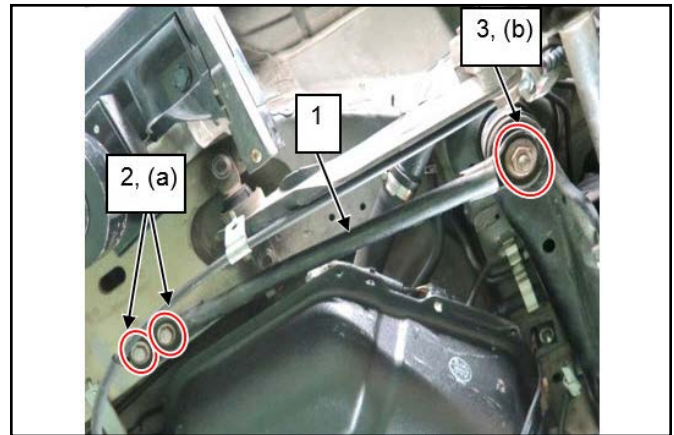

NOTICE

The trailing arm front bolt is pre-coated with friction stabilizer. If the bolt is reused, it may work loose.

Never reuse the trailing arm front bolt.

- h) Tighten the trailing arm front bolts to specified torque.

Tightening torque

**Trailing arm front bolt (a):
75 N·m (7.6 kgf-m, 55.5 lbf-ft)**

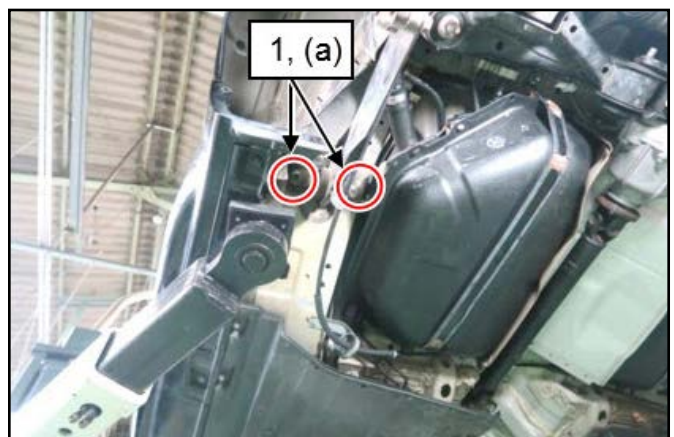

- i) Connect the coupling assembly connector (1) and coupling air temperature sensor connector (2).

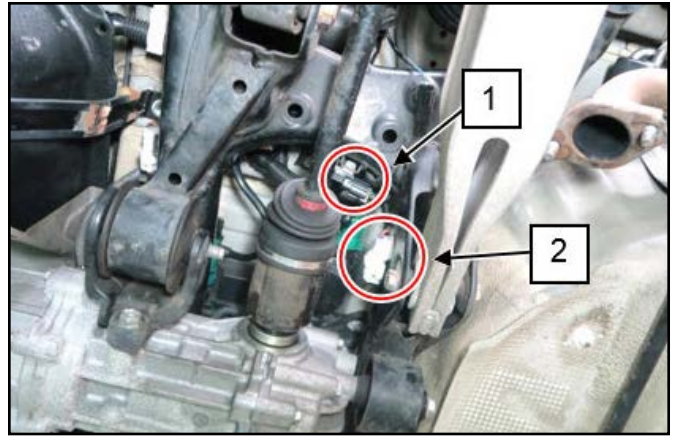

- j) Install the rear brake caliper (1) and tighten the rear brake caliper pin bolts (2) to the specified torque.

Tightening torque
Rear brake caliper pin bolt (a):
23 N·m (2.3 kgf-m, 17.0 lbf-ft)

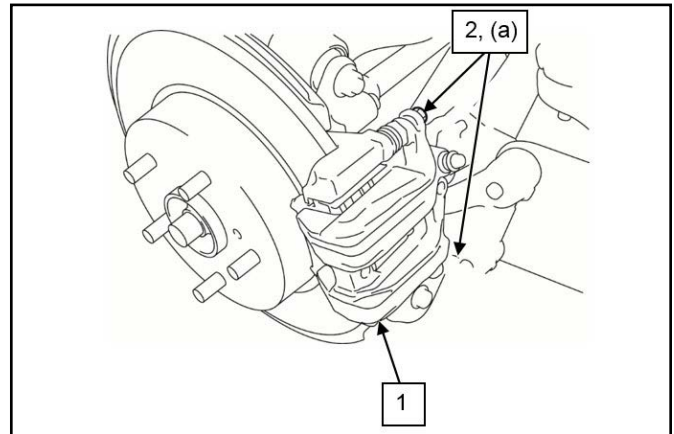

- k) Tighten the rear shock absorber support bolts in numerical order (1 - 3) to the specified torque.

Tightening torque
Rear shock absorber support bolt (a):
60 N·m (6.1 kgf-m, 44.5 lbf-ft)

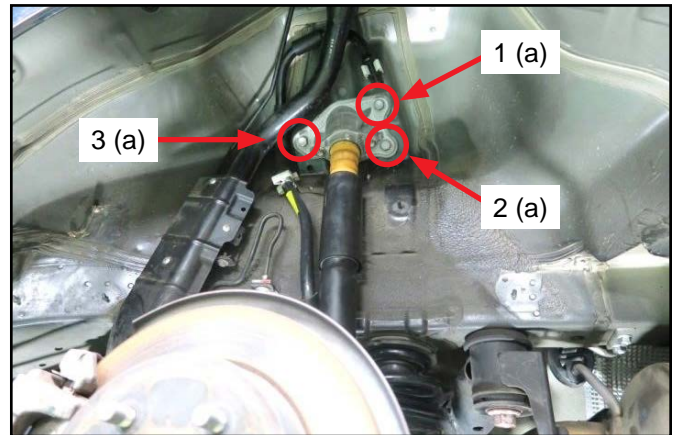

- l) Install the propeller shaft and tighten the new center support bolts (1) to the specified torque.

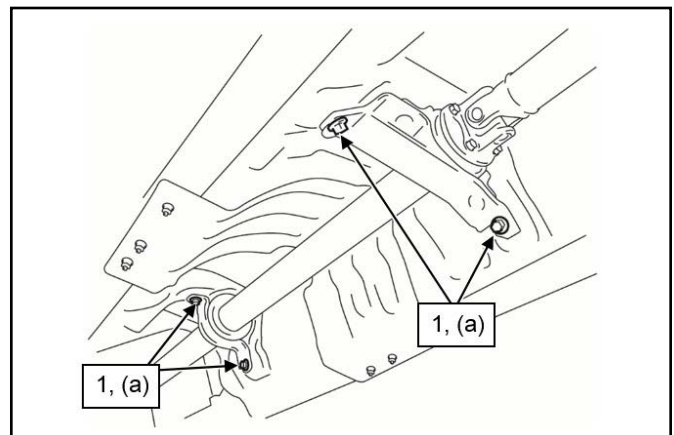

NOTICE

The center support bolt is pre-coated with friction stabilizer. If the bolt is reused, it may work loose.

Never reuse the center support bolt.

Tightening torque
Center support bolt (a):
45 N·m (4.6 kgf-m, 33.5 lbf-ft)

- m) Align the match mark (1) of each flange when installing propeller shaft.
- n) Tighten the new propeller shaft front bolts (2) and new rear bolts (3) to the specified torque.

NOTICE

The propeller shaft front bolt and propeller shaft rear bolt are pre-coated with friction stabilizer or adhesive. If these bolts are reused, they may work loose.

Never reuse the propeller shaft front bolt and propeller shaft rear bolt.

Tightening torque

Propeller shaft front bolt (a):
26 N·m (2.7 kgf-m, 19.5 lbf-ft)

Propeller shaft rear bolt (b):
33 N·m (3.4 kgf-m, 24.5 lbf-ft)

- o) Install heat protector panel No. 1 (1) and tighten the new heat protector panel No. 1 nuts to the specified torque.

Tightening torque

Heat protector panel No. 1 nut (a):
2.0 N·m (0.2 kgf-m, 1.5 lbf-ft)

- 5) Install rear left fender lining and attach with clips in the positions noted.

NOTE:

The rear fender lining is secured with three types of clips. Refer to the illustrations shown below.

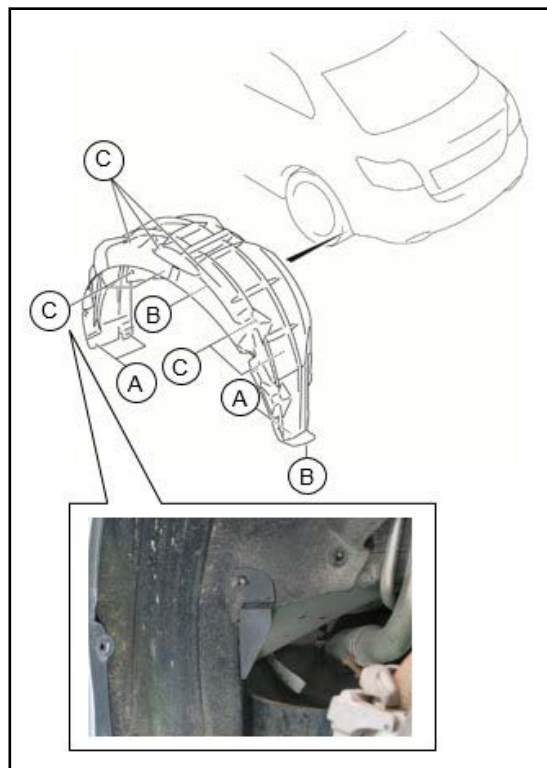
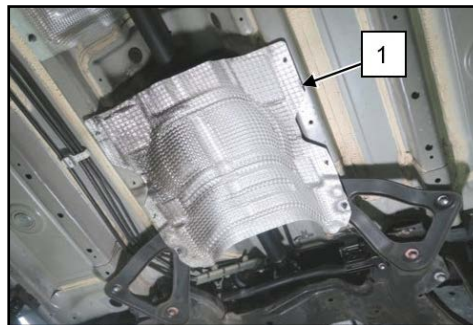
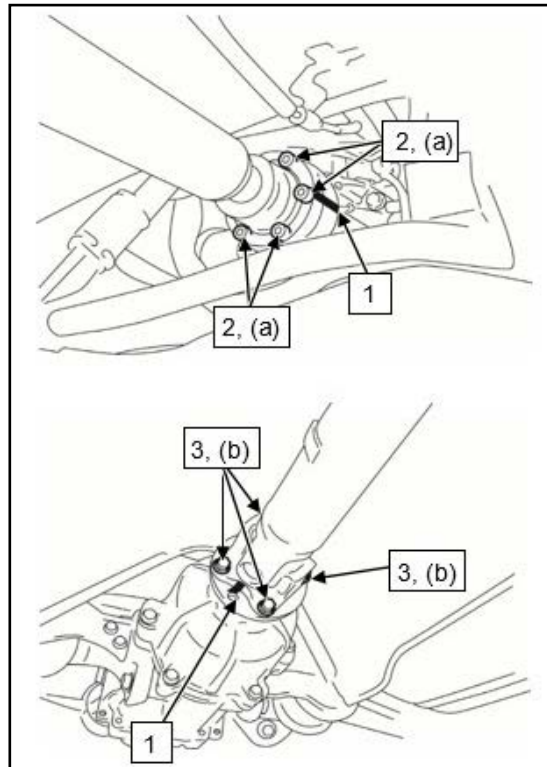
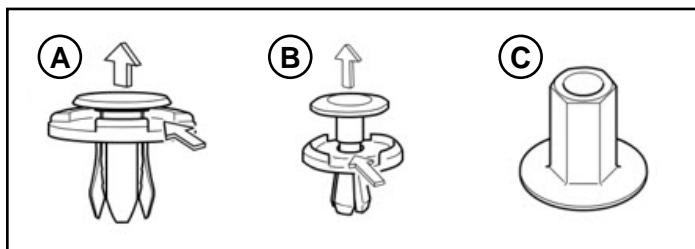

- 6) Install the rear wheels and tighten the wheel nuts in the positions noted and secure them according to the specified torque.

Tightening order: 1 – 2 – 3 – 4 – 5

Tightening torque

Wheel nut (a):

140 N·m (14.3 kgf-m, 103.5 lbf-ft)

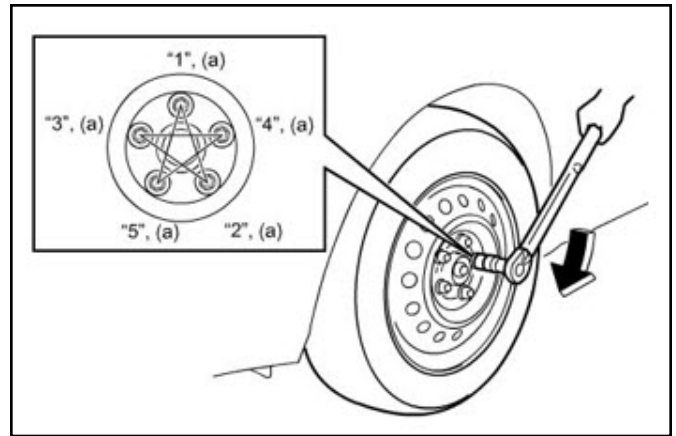

- 7) Install the new exhaust pipe gaskets (1).

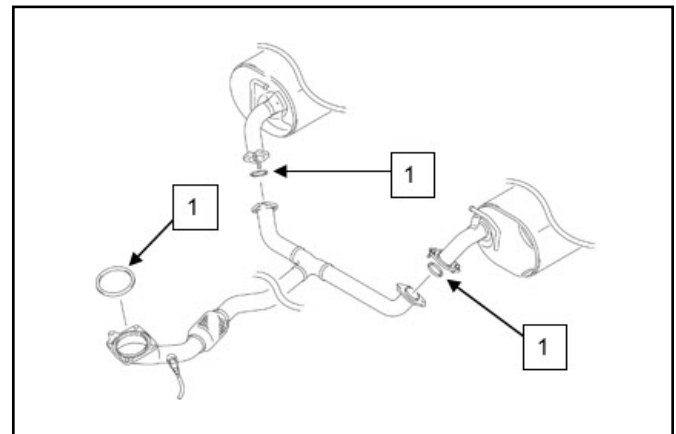

- 8) Lift the exhaust pipe with a transmission jack (1).
- 9) Install the exhaust pipe to mounting No. 1 (2) and mounting No. 2 (3).

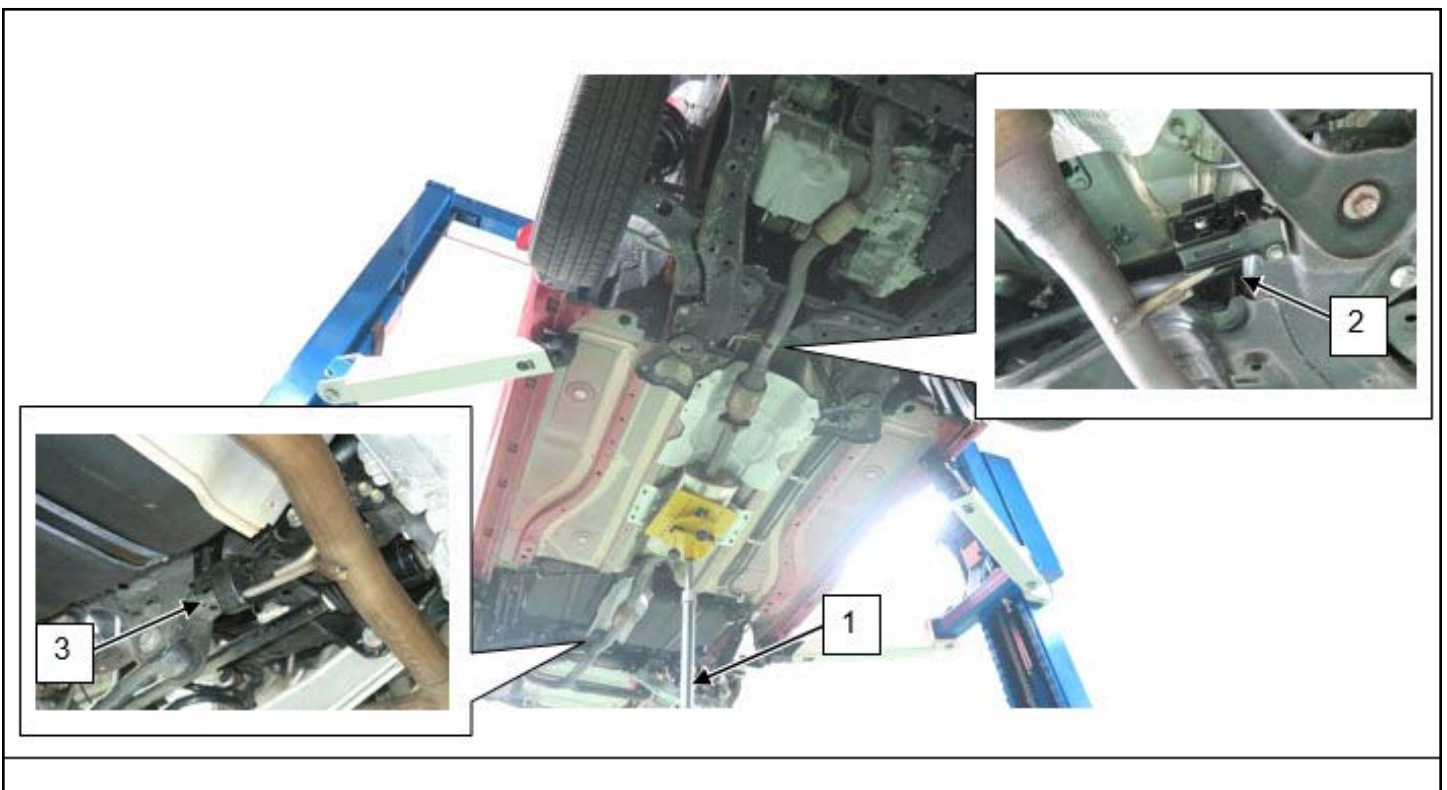

- 10) Tighten the exhaust pipe No. 2 nuts (1) to the specified torque.

Tightening torque

Exhaust pipe No. 2 nut (a):
50 N·m (5.1 kgf-m, 37.0 lbf-ft)

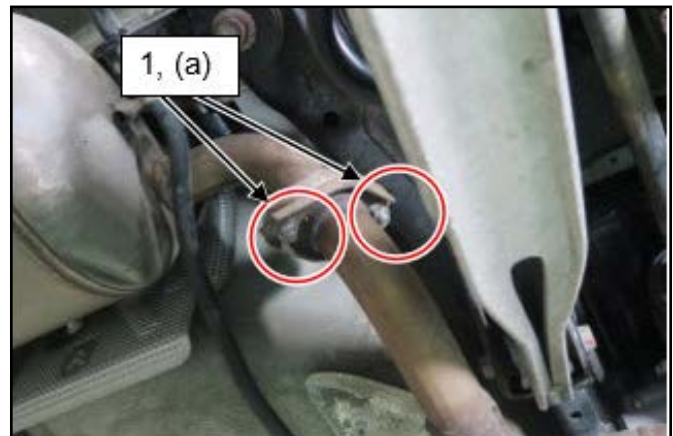
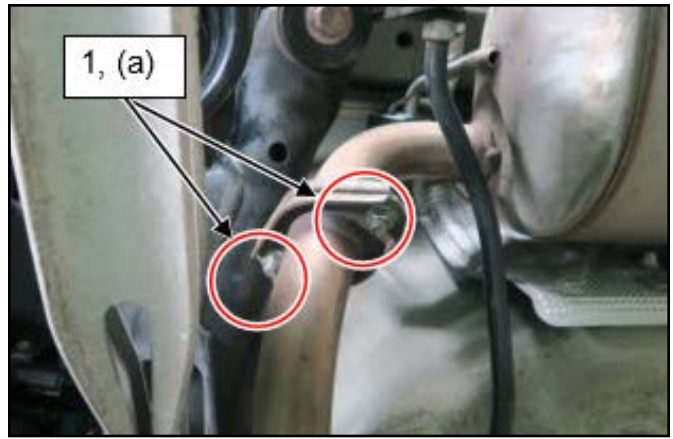

- 11) Install the exhaust manifold support bracket (1) and tighten the exhaust pipe No. 1 bolts (2) to the specified torque.

Tightening torque

Exhaust pipe No. 1 bolt (a):
50 N·m (5.1 kgf-m, 37.0 lbf-ft)

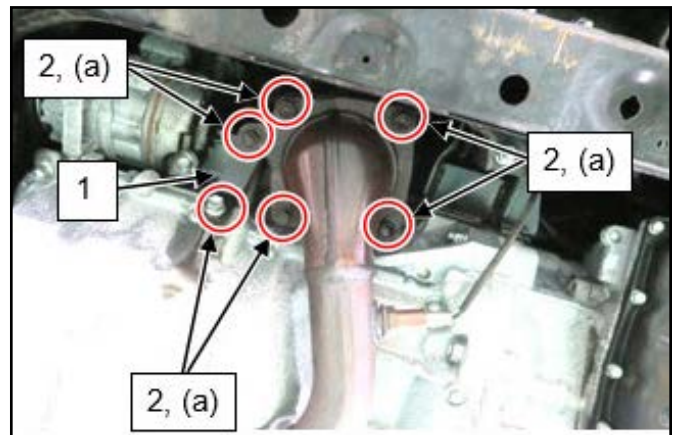

- 12) Connect the HO2S connector (1).



- 13) Install side engine undercover left (1) and right (2), and tighten bolts (3).

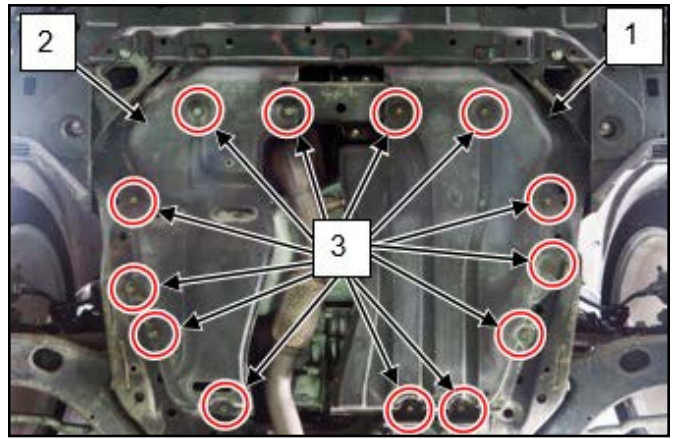

- 14) Install the floor tunnel front brace (1) and tighten the floor tunnel front brace bolts (2) to the specified torque.

Tightening torque

Floor tunnel front brace bolt (a):
37 N·m (3.8 kgf-m, 27.5 lbf-ft)

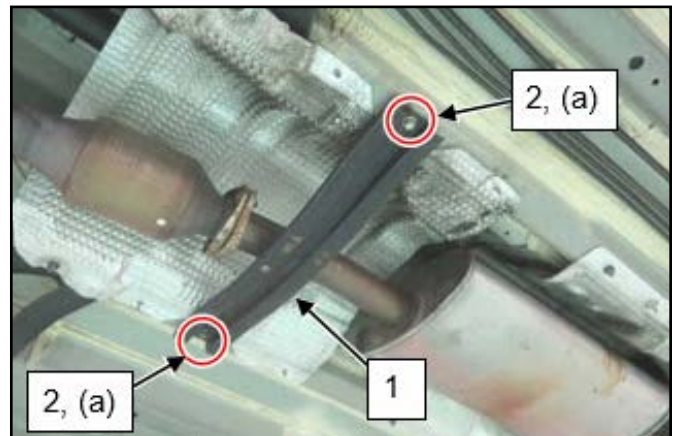

- 15) Install the floor tunnel rear bar (1) and tighten the floor tunnel rear bar bolts (2) to the specified torque.

Tightening torque

Floor tunnel rear bar bolt (a):
37 N·m (3.8 kgf-m, 27.5 lbf-ft)

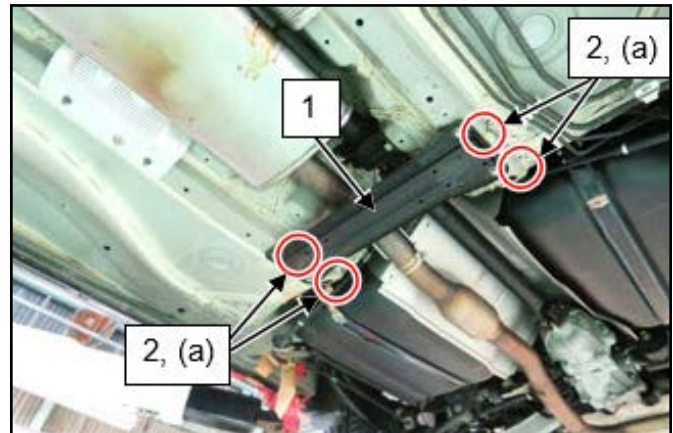

- 16) Install the left (1) and right (2) main floor undercover.
- 17) Install the clips (3).
- 18) Tighten the main floor undercover bolts (4) and new main floor undercover nuts (5) to the specified torque.

Tightening torque

Main floor undercover bolt (a):
5.5 N·m (0.56 kgf-m, 4.0 lbf-ft)

Main floor undercover nut (b):
2.4 N·m (0.24 kgf-m, 2.0 lbf-ft)

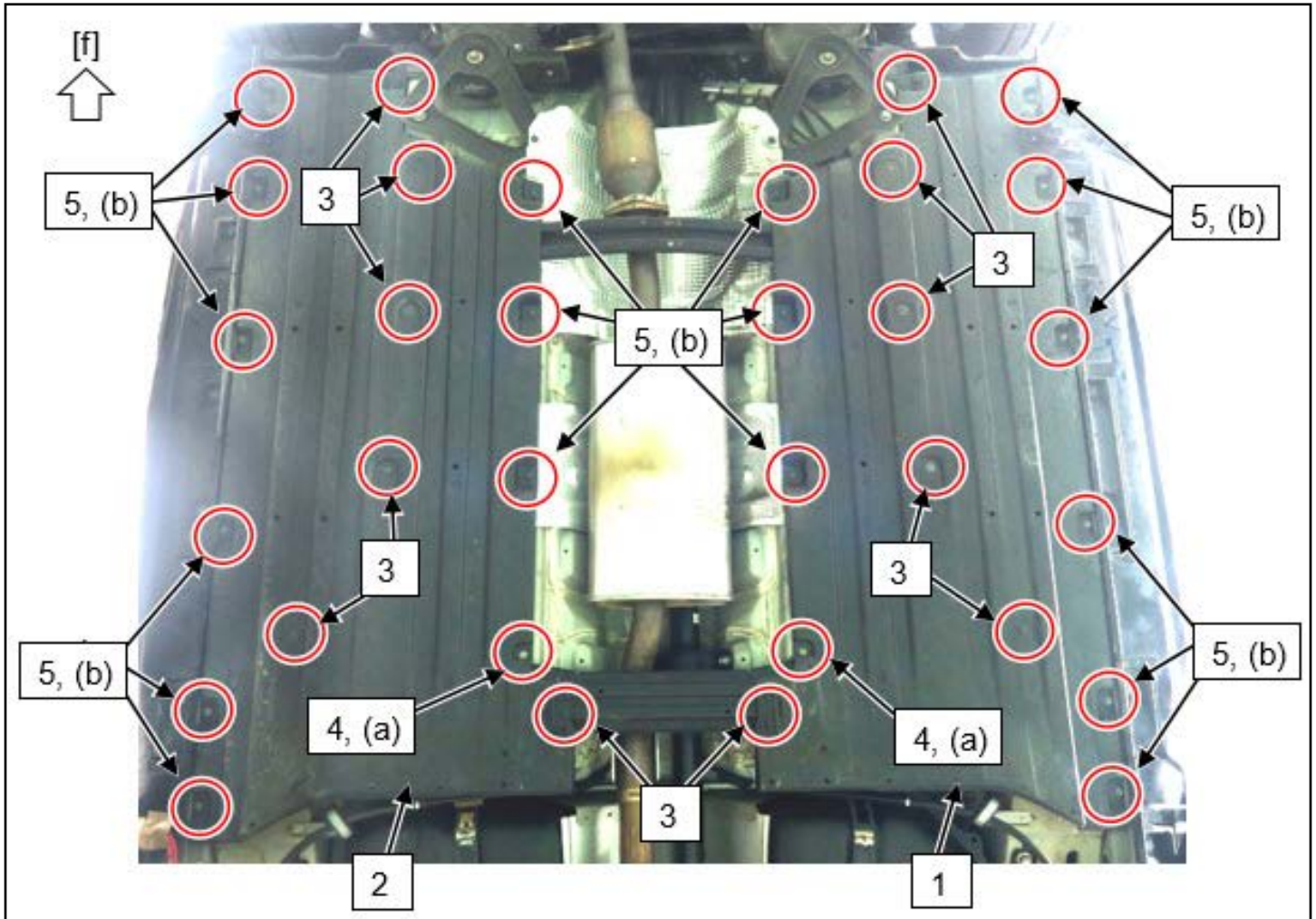

- 19) Connect negative (-) cable to battery.
- 20) Reinstall the fuel pump relay (2) into the main fuse box (1), which was removed in step 1C on page 17.
- 21) Apply fuel pressure to fuel feed line according to the following procedure.
 - a) Push the engine switch to change the ignition mode to **ON** and to operate fuel pump.
 - b) After 2 seconds, push the engine switch to change the ignition model to **OFF**.
 - c) Repeat Steps A and B above three or four times.
- 22) Check that there are no fuel leaks from any part of fuel system.
- 23) Run the engine and check for exhaust gas leaks.

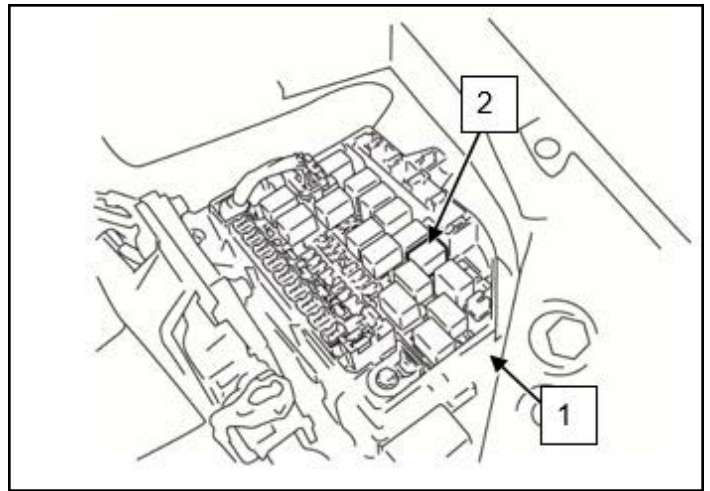

CALIBRATION AND INITIALIZATION PROCEDURES, REPAIR COMPLETION STICKER

- 1) Using the Service Manual references below, perform the throttle control system calibration and power window system initialization.

Section 1C - Engine General Information and Diagnosis > Electric Throttle Body Control System Calibration

Section 9E - Glass / Windows / Mirrors > Power Window System Initialization / Reset (Front Windows Only)
- 2) Reset the clock and the customer's radio presets.
- 3) Fill in the completion repair sticker and attach it to the vehicle as instructed on the next page.
- 4) Fill in the Vehicle Emission Recall - Proof of Correction card and give it to your customer as instructed on the next page.



SUZUKI MOTOR OF AMERICA, INC.

Dear Suzuki Service Provider,

Please use the enclosed items to complete the 2010 - 2013 Kizashi Fuel Tank Canister Vent Pipe Recall Campaign. After you have completed the repairs, do the following:

Repair Completion Sticker:

All Service Providers:

- 1) Write "CY" in the top box of the repair completion sticker using a permanent marker or pen with black ink such as a Sharpie® brand marker with a fine point.
- 2) Write your six-digit Service Provider Number in the bottom box.
- 3) Attached the sticker to the vehicle as shown below.

KIZASHI CAMPAIGN					
C		Y			
SUZUKI SERVICE PROVIDER #					
4	0	0	2	0	0

Sample

Attach the repair completion sticker to front bumper/facia, forward of the air cleaner.

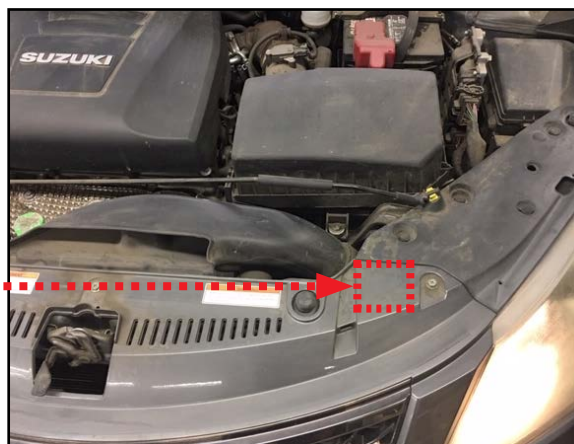

For California Dealers:

In addition to attaching a repair completion sticker:

- 1) Complete a Vehicle Emission Recall - Proof of Correction certificate and give it to your customer at the time of delivery.
Write "CY" in the Recall Number section of the card.
- 2) Explain to your customer that it is important for them to save this certificate as they may need to provide it to the California Department of Motor Vehicles when renewing their vehicle registration.

Vehicle Emissions Recall - Proof of Correction					
License Number	Make	Model Year	Body Type	Vehicle Identification Number	
				[Grid for VIN]	
Manufacturer			Recall Number CY		
The above described vehicle has been repaired, modified and/or equipped with new emission control devices to meet applicable California Emission Control Laws.					
Service Provider Name			Address, City, State and ZIP		
Date			Service Provider Authorized Signature		
Return this certificate to DMV <u>ONLY</u> when required. Otherwise, retain for your records.					

Sample

If your dealership needs more repair completion stickers and/or Proof of Correction certificates, contact your District Service and Parts Manager or Tech-Line at (800) 934-1616.