

Inspecting and Tightening Carrier Mounting Bolts

Certain Trailers Equipped with Air Disc Brakes

Hazard Alert Messages

Read and observe all Warning and Caution hazard alert messages in this publication. They provide information that can help prevent serious personal injury, damage to components, or both.

⚠ WARNING

To prevent serious eye injury, always wear safe eye protection when you perform vehicle maintenance or service.

Park the vehicle on a level surface. Block the wheels to prevent the vehicle from moving. Support the vehicle with safety stands. Do not work under a vehicle supported only by jacks. Jacks can slip and fall over. Serious personal injury and damage to components can result.

⚠ ASBESTOS AND NON-ASBESTOS FIBERS WARNING

Some brake linings contain asbestos fibers, a cancer and lung disease hazard. Some brake linings contain non-asbestos fibers, whose long-term effects to health are unknown. You must use caution when you handle both asbestos and non-asbestos materials.

How to Obtain Additional Maintenance, Service and Product Information

Refer to Maintenance Manual MM-0467, EX+™ Air Disc Brake. To access this publication, visit Literature on Demand at Meritor.com.

How to Obtain Kits

Call Meritor's Commercial Vehicle Aftermarket at 888-725-9355.

Table A: Replacement Parts

Brake Model	Kit Number	Includes	Qty.
EX225L257CD000 and EX225L258CD000	KIT225225	41X1862 (50 mm M20 x 2.0-6g Grade 10.9)	6
		MWA 520P	6

Brake Model	Kit Number	Includes	Qty.
EX225L202CD000 and EX225L201CD000	KIT225226	41X1484V (60 mm M20 x 1.5-6g Grade 10.9)	6
		MWA 520P	6
Non-Meritor	KIT225261	MS220050AM 2 (50 mm M20 x 2.5-6g Grade 10.9)	6
		MWA 520K	6

Inspecting and Tightening Carrier Mounting Bolts

This technical bulletin provides instructions for inspecting the carrier mounting bolts and tightening the bolts to the correct torque specification. This inspection only applies to certain axles on a limited number of trailers.

Caliper Model Identification

Meritor EX+ Calipers

To identify Meritor EX+ calipers, remove the protective cap from the adjuster screw and look for the part number engraved in the metal plate (EX225...). Figure 1.

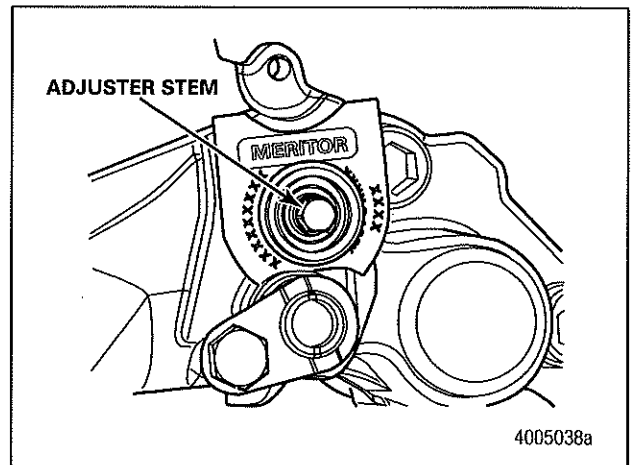

Figure 1

4005038a

Non-Meritor Caliper

To identify non-Meritor calipers, refer to the appropriate manufacturer's service manual for the ID tag location.

Inspection Procedure

1. Wear safe eye protection. Park the trailer on a level surface.
2. Raise the trailer by the ICC bar so that the axles drop down allowing access to the caliper mounting bolts. Support the trailer with jack stands.
3. Locate the carrier mounting bolts and check if any of the bolts are missing. Figure 2, Figure 3, Figure 4 and Figure 5.

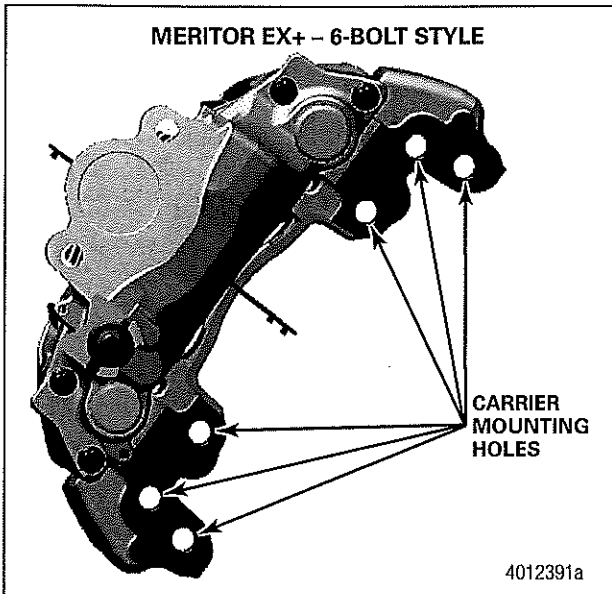

Figure 2

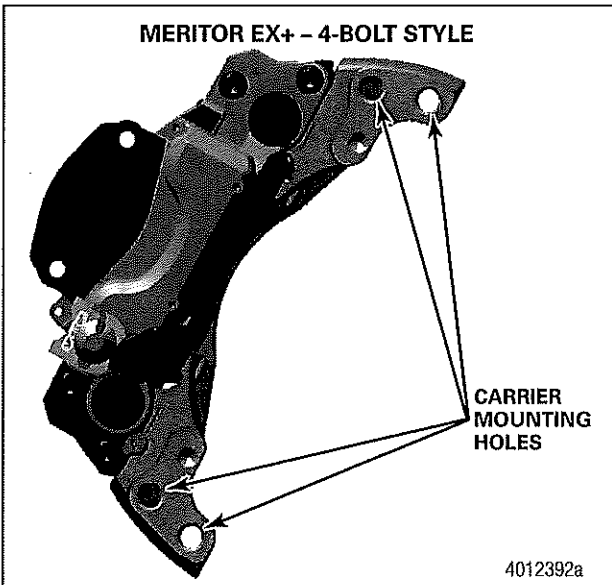

Figure 3

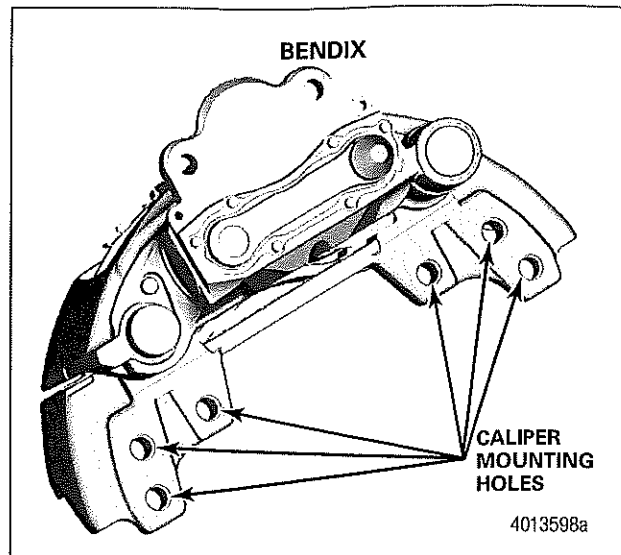

Figure 4

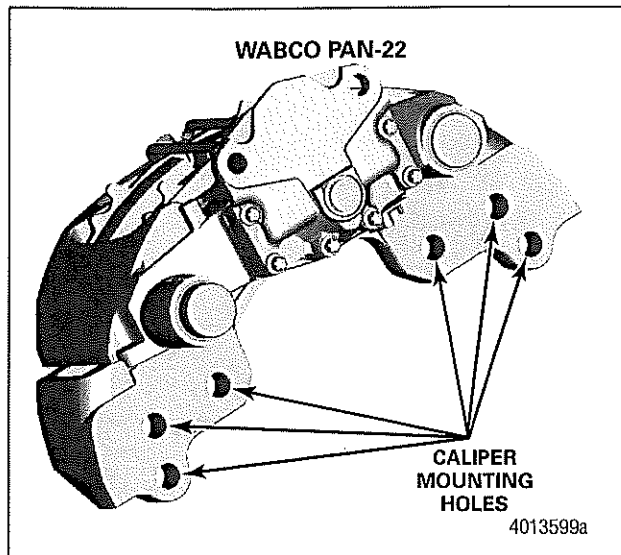





Figure 5

- If no bolts are loose (hand tight) or missing: Proceed to Step 4.
 - If one (1) bolt is loose (hand tight) or missing: Use the appropriate kit to replace all of the mounting bolts with new bolts and washers. Proceed to Step 4.
 - If more than one (1) bolt is loose (hand tight) or missing: Proceed to the "Caliper and Torque Plate Inspection" procedure in this publication.
4. Use an appropriate-length torque wrench to tighten the carrier mounting bolts at all wheel end positions on the trailer.

- **For Meritor EX+ air disc brakes:** Use a 30 mm-size socket to tighten the carrier mounting bolts to 400 lb-ft (542 N•m). Use the special torque adapter, part number 3256B1354, where needed for access to the mounting bolts. When using the special torque adapter, use the settings shown in Table B for torque compensation. Figure 6. 
- **For Bendix brakes:** Tighten the carrier mounting bolts to 350-400 lb-ft (475-542 N•m). 
- **For WABCO PAN-22 brakes:** Tighten the carrier mounting bolts to 270-310 lb-ft (366-420 N•m). 

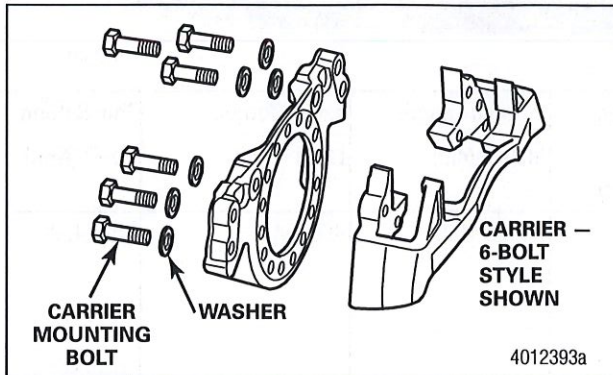





Figure 6

5. Use a white or yellow paint pen to mark the head of each bolt indicating that Step 4 has been completed.
6. When all of the caliper bolts at each wheel end have been inspected, remove the jack stands and lower the trailer.

Caliper and Torque Plate Inspection

1. Raise the axle being serviced and support it with jack stands.
2. Remove the wheels.
3. Back off the caliper adjuster.
 - **For EX+ calipers:** Refer to Maintenance Manual MM-0467 for instructions.
 - **For non-Meritor calipers:** Refer to the appropriate manufacturer's service manual for instructions.
4. Remove the caliper.
 - **For EX+ calipers:** Refer to Maintenance Manual MM-0467 for instructions.
 - **For non-Meritor calipers:** Refer to the appropriate manufacturer's service manual for instructions.
5. Inspect the caliper and torque plate for damage.
 - **If damage is found:** Inspect the rotor, caliper and pads. Take clear photos of damage on all components for submitting to the Meritor OnTrac™ Customer Call Center. Replace damaged components.

- **If no damage is found:** Proceed to the next step.
6. Use the appropriate kit to replace all of the mounting bolts with new bolts and washers.
 7. Install the caliper.
 - **For EX+ calipers:** Refer to Maintenance Manual MM-0467 for instructions.
 - **For non-Meritor calipers:** Refer to the appropriate manufacturer's service manual for instructions.
 8. Use an appropriate-length torque wrench to tighten the carrier mounting bolts at all wheel end positions on the trailer.
 - **For Meritor EX+ air disc brakes:** Use a 30 mm-size socket to tighten the carrier mounting bolts to 400 lb-ft (542 N•m). Use the special torque adapter, part number 3256B1354, where needed for access to the mounting bolts. When using the special torque adapter, use the settings shown in Table B for torque compensation. 
 - **For Bendix brakes:** Tighten the carrier mounting bolts to 350-400 lb-ft (475-542 N•m). 
 - **For WABCO PAN-22 brakes:** Tighten the carrier mounting bolts to 270-310 lb-ft (366-420 N•m). 
 9. Use a white or yellow paint pen to mark the head of each bolt indicating that Step 8 has been completed.
 10. Readjust the pad-to-rotor clearance.
 - **For EX+ calipers:** Refer to Maintenance Manual MM-0467 for instructions.
 - **For non-Meritor calipers:** Refer to the appropriate manufacturer's service manual for instructions.
 11. Install the wheels per OEM guidelines.
 12. Remove the jack stands and lower the axle.

Labor Time

Standard Repair Time (SRT)

- **0.25 hours** – Administrative (per trailer regardless of number of axles)
- **0.75 hours** – Inspection and torque (per axle)
- 1.25 hours – Remove and, if applicable, replace caliper
- 1.25 hours – Replace rotor (including removing hub and replacing wheel seal)
- 0.5 hours – Replace torque plate

Example: To inspect a sliding tandem axle set, the SRT would be 1.75 hours (0.25 + 0.75 + 0.75)

To File a Claim

For questions or when the repair has been completed, contact the Meritor OnTrac™ Customer Call Center by phone at 1-866-OnTrac1 (668-7221) or via email at OnTrac@meritor.com.

Reference Campaign Program C17AB.

Table B: Torque Compensation with Meritor Extension Tool 3256B1354

All torque settings are +/- 40 lb-ft (+/- 54 N•m)

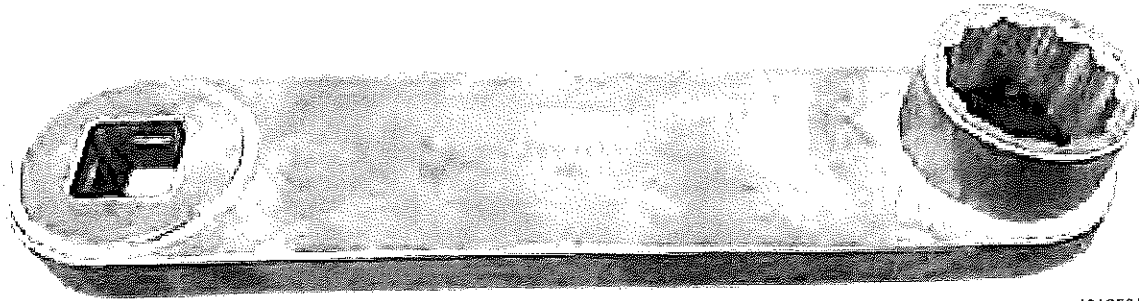

4013581a

Angle View	Extension Angle (Degrees)	Wrench Length Inches (cm)	Target Torque Lb-Ft (N•m)	Tool Setting Lb-Ft (N•m)
<p>4013582a</p>	0	43.5 (110.5)	400 (542)	334 (453)
<p>4013583a</p>	45			364 (494)
<p>4013584a</p>	90			400 (542)
<p>4013585a</p>	135			444 (602)



Meritor Heavy Vehicle Systems, LLC
 2135 West Maple Road
 Troy, MI 48084 USA
 866-OnTrac1 (868-7221)
 meritor.com

Information contained in this publication was in effect at the time the publication was approved for printing and is subject to change without notice or liability. Meritor Heavy Vehicle Systems, LLC, reserves the right to revise the information presented or to discontinue the production of parts described at any time.

Copyright 2017
 Meritor, Inc.
 All Rights Reserved

Printed in USA

TP-15141
 Revised 09-17
 (16579)



Parts, Labor and Handling Allowance

The following are the details of allowances relating to parts, labor and handling available to vehicle manufacturers' (OEM):

- Administration (per trailer regardless of number of axles) – 0.25 hours
- Inspection and torque (per axle) – 0.75 hours
- Remove and, if applicable, replace caliper – 1.25 hours
- Replace rotor (including removing hub and replacing wheel seal) – 1.25 hours
- Replace torque plate – 0.5 hours

Claims for Credit

Meritor will accept warranty claims for inspecting, tightening, and replacement of any resultant component damage associated with this notice directly from the vehicle manufacturers (OEM). To obtain credit for the claim; the repair facility should file with its OEM and the OEM will reimburse the repair facility for the work. Meritor will reimburse the OEM through its standard warranty process.

In order to receive proper credit, such warranty claims must contain the following information at the time of submission:

- Reference to Meritor Campaign ID Number: C17AB
- Reference to NHTSA Campaign ID Number : 17E049
- Reference to the vehicle manufacturer's campaign number (optional)
- 17-digit vehicle identification number (VIN)
- Vehicle owner's name, address, and telephone number
- Vehicle in-service date
- Vehicle repair date
- Vehicle mileage at the time of repair
- Dealer work order number
- Repairing facility name, address, and telephone number
- Total labor hours required performing the work, not to exceed agreed formula
- Repair facilities hourly rate
- Tracking number for shipment of returned material

Failure to provide complete information will delay processing of the warranty claim.



Communication

If you conclude that Meritor has not enabled you to remedy this condition in a reasonable time, you may submit a complaint to the:

Administrator
National Highway Traffic Safety Administration
1200 New Jersey, S.E.
Washington, D.C. 20590

- or -

Call the toll free Vehicle Safety Hotline: 1-888-327-4236; (TTY: 800-424-9153)
or go to <http://www.safercar.gov>

We regret any inconvenience that this situation may cause. Meritor wants to assure you that we are concerned for customer safety and your continued satisfaction with our products.

Sincerely,

Johnathan Christopher
Director of Quality, Global Aftermarket & Trailer
Meritor, Inc.

Enclosures:
Axle Serial number and/or VIN List
Meritor Technical Publication No. TP-15141