

Bulletin Type.....: Safety Recall

Bulletin No.....: TS-S123 (Rev01)

**Bulletin Name.....: Tag Axle Air Bellow Protection
Cover**

Bulletin Ref No.....: 700003328

Revision No.....: 01

NHTSA.....: 17V470

Release Date.....: 21.12.2017

Vehicle Model.....: TS45

Fiat Rate Code.....: TS-S123

Flat Rate Time.....: 45'

Subject: Replacement of bended or deformed tag axle air bellow protection cover.

Summary: This bulletin is made to replace bended or deformed air bellow cover with a new cover.

Rev. Details: This bulletin has been revised to add visual inspection process of the tag axle tires.

Bulletin Responsible: Serhat CELEPCI

Published by&Approved by: Hakan GÜNERDEM

Welding on the Chassis

- Always disconnect the batteries (starting with the negative lead).
- Disconnect the connectors of electrical and electronic equipment (electronic control units, sensors and actuators) if they are less than 2 meters away from the chassis part to be welded or the earth terminal of the welding equipment.
- The earth terminal should never be attached to vehicle components such as engine, axles and springs. Arcing on these parts is not permitted, because of the risk of damage to bearings, springs, etc.
- The earth terminal must make good contact and be placed as close as possible to the part to be welded.
- Plastic pipes, rubber parts and parabolic springs should be well protected against welding spatter and temperatures higher than 70°.
- The contact switch must not be in the accessory or contact position. The contact key should be removed.

GENERAL PRECAUTIONS

1. Suggested Dress Code:

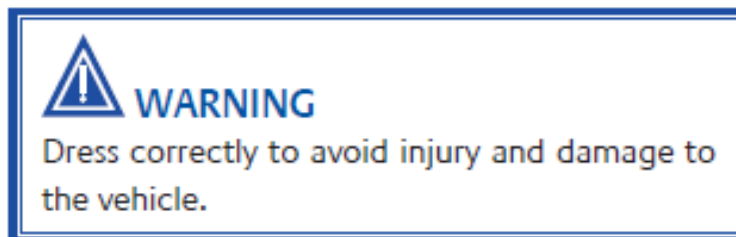



2. Before Starting the Work:

Always wear protective clothing. Do not wear any damaged or loose-fitting clothing and remove jewelry before starting the work. In case of long hair use hairnet. The illustration above shows some of the correct and incorrect clothing that should be worn during work. Sharp edges should be avoided e.g belts, watches, necklaces etc.

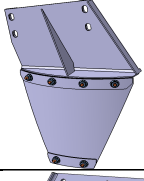
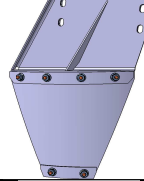
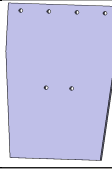

3. Interior materials protection:

Seats, trimming, upholstery stuff and carpeting should be protected with appropriate coverings.

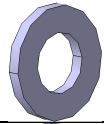
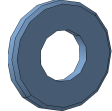
Installed Part List

No	Part No	Part Name	Picture	Qty	Unit Of Measure
1	9325-4932Y	SHEET METAL BRACKET, BELLOW GUARD, TAG AXLE, RIGHT SIDE		1	Pc
2	9325-4933Y	SHEET METAL BRACKET, BELLOW GUARD, TAG AXLE, LEFT SIDE		1	Pc
3	RP353108Y	SPLASH GUARD, AIR BELLOW, TAG AXLE		2	Pcs
4	MF100057Y	BOLT HEX (M8X1,25X25) K:5,8		8	Pcs
5	MF450405Y	WASHER, SPRING (B 8) (2X8X24)		8	Pcs
6	MF450005Y	WASHER,PLAIN (8)		8	Pcs

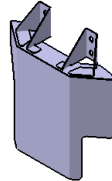
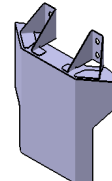
Excluded Part List

No	Part No	Part Name	Picture	Qty	Unit Of Measure
1	9325-3787Y	SHEET, BELLOW GUARD, TAG AXLE, RIGHT SIDE		1	Pc
2	9325-3788RY	SHEET, BELLOW GUARD, TAG AXLE, LEFT SIDE		1	Pc
3	MF100054Y	BOLT (M8X1.25X18) K:8.8		8	Pcs

TECHNICAL INSTRUCTIONS

Application-1: Removal Procedure

- a- Before starting the operation lift the vehicle by pushing the kneeling/lifting button placed on dashboard, see in Figure -1. Thus enough space will be achieved for the following processes (**See Figure-1**)



Figure -1: Kneeling/lifting operation



Figure - 2:

- b- Location of the tag axle air bellow at road side

If current air bellow protection covers still exist on the vehicle, remove them by loosening the bolts, (**See Figure-3**)

c- After the visual inspection of the tag axle tires, if the surface of the tires are damaged then replace the damaged tire with a new one according to Temsa tire specifications.

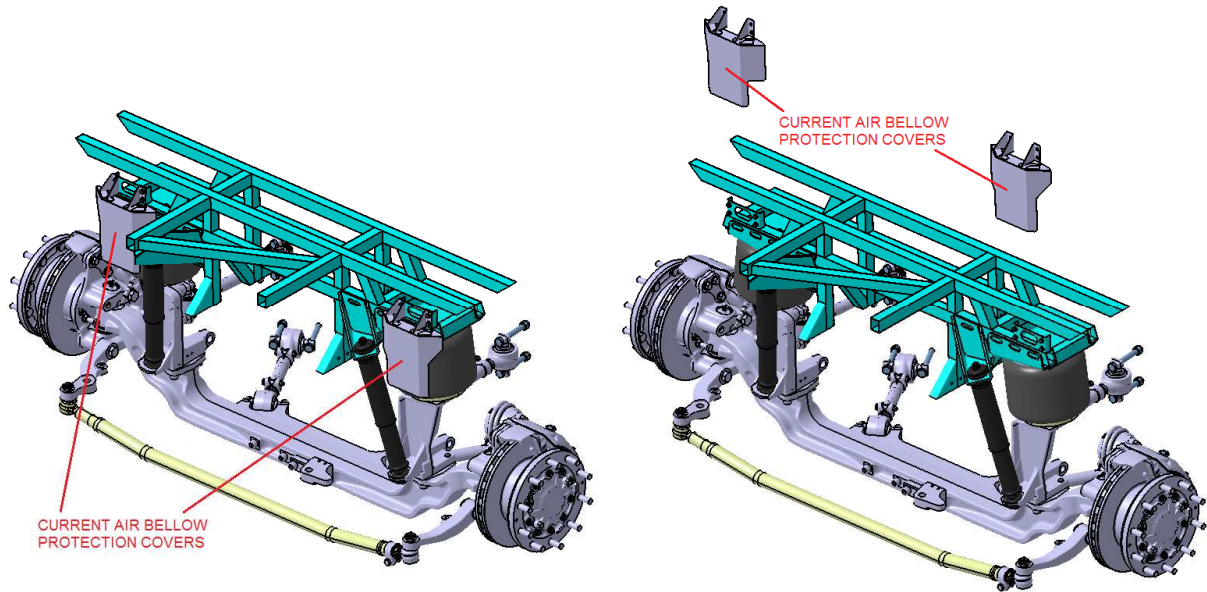

Figure - 3

Figure - 3: Removal of existing air bellow protection covers of tag axle

Application-2: Subassembly Procedure

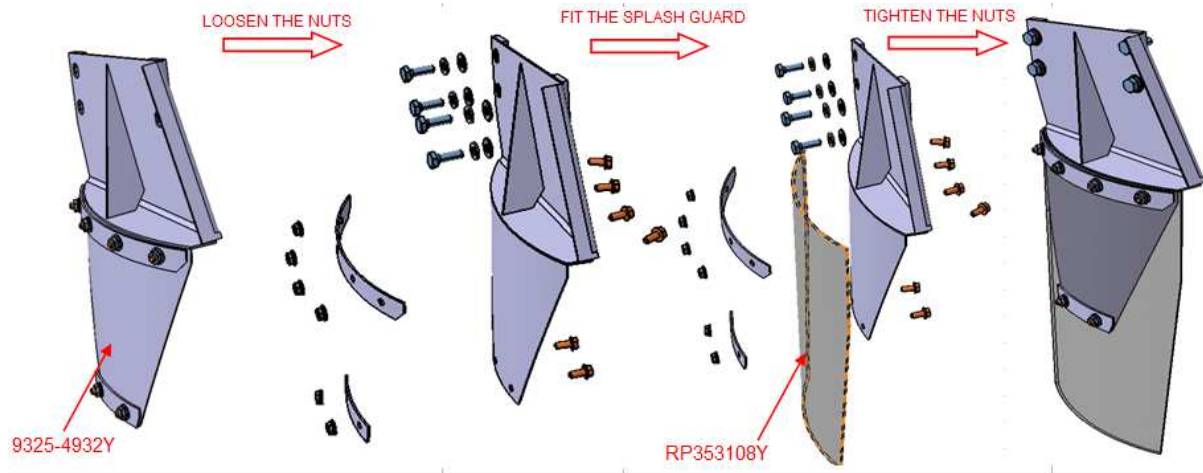

Figure – 4

Note: Same subassembly process is also valid for the air bellow protection cover at right side

Application-3: Installation Procedure

Install both air bellow protection covers to the vehicle, see in **Figure-5** and **Figure-6**.

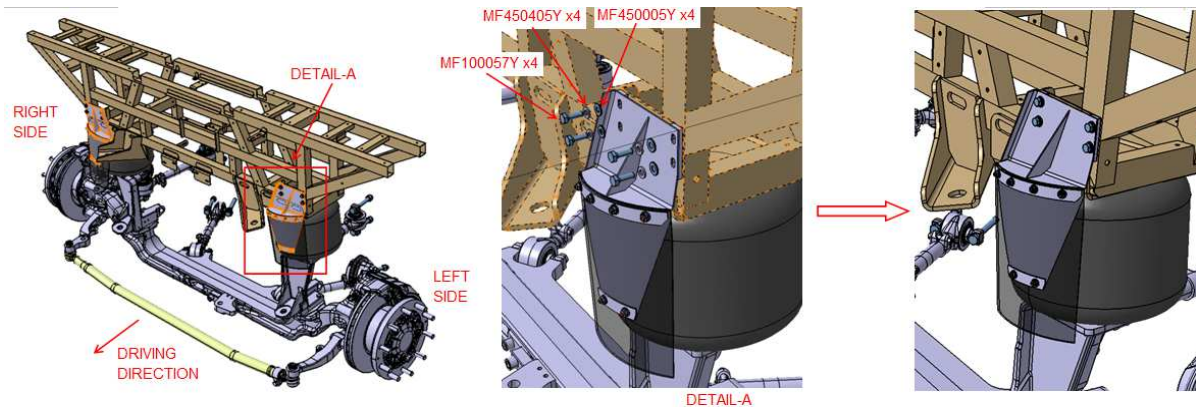

Figure - 5: Fix the protection cover at left side by the bolts given in DETAIL -A (tightening torque is 8 lbft).

Note: Same installation process is also valid for the one at right side

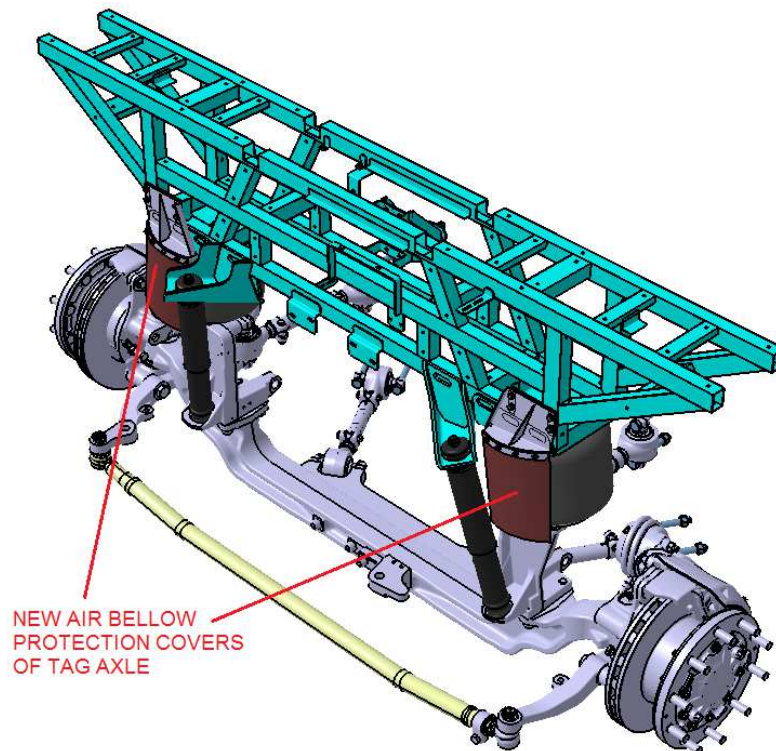

Figure - 6: New air bellow protection covers installed to the vehicle



SERVICE BULLETIN

RATE BREAK DOWN

Application	Time
Removal Procedure	15'
Subassembly Procedure	15'
Installation Procedure	15'
Total	45 min.