



“RENOTIFICATION”

IMPORTANT SAFETY RECALL

2014-2016 Mazda3 and 2014-2015 Mazda6
Hand-Operated Parking Brake Concern Safety Recall 1217F
NHTSA Campaign No. 17V-393

June 2023

This notice applies to your vehicle: VIN _____

Dear Mazda Owner:

This notice is sent to you in accordance with the National Traffic and Motor Vehicle Safety Act. Mazda Motor Corporation has decided that a defect which relates to motor vehicle safety exists in certain 2014-2016 Mazda3 vehicles produced from January 6, 2014 through September 2, 2016, and 2014-2015 Mazda6 vehicles produced from October 25, 2012 through December 1, 2014.

As of the date of this notice, your vehicle remains unrepaired.

What is the problem?

On the mechanical (cable) type parking brake, water may enter the brake caliper due to inappropriate sealing performance of the rear brake caliper protective boot, in cold temperatures. As a result, the parking brake actuator shaft, which is a component of the rear brake caliper, may rust increasing the sliding resistance of the actuator shaft. The rusted actuator shaft may stick in the brake caliper body, resulting in the rear brakes dragging while driving and a decreased parking brake holding force. This could result in unexpected movement of the vehicle if parked on a slope, increasing the risk of a collision.

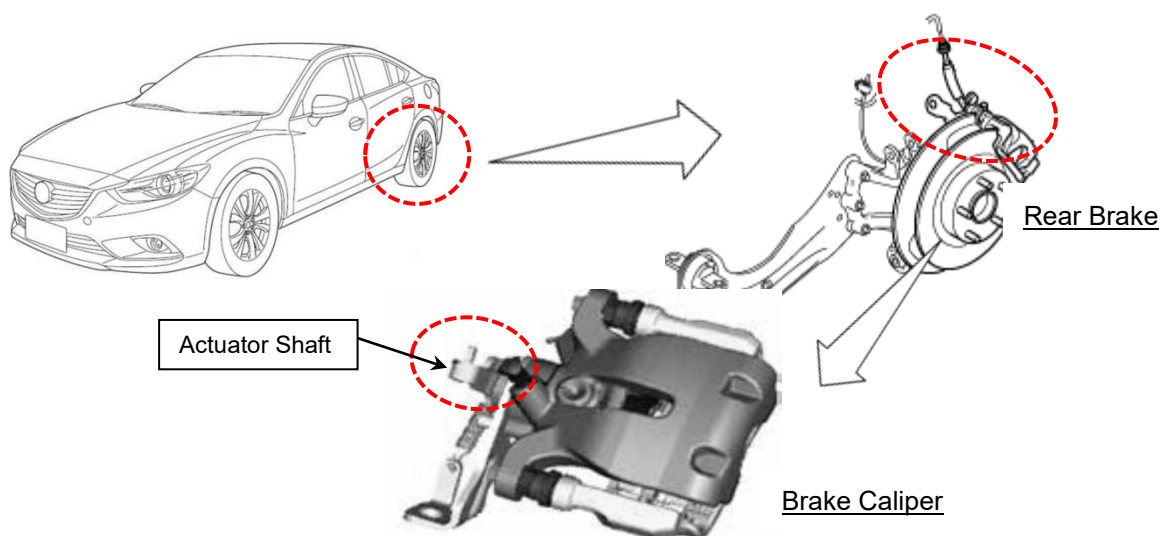

What will Mazda do?

Protect What Is Important To You

Your Mazda dealer will check the parking brake actuator shafts inside the left and right rear brake calipers. If the actuator shaft is found to be rusted, the brake caliper assembly will be replaced with a modified one. If no rust is found on the actuator shaft, the protective boot will be replaced with a modified one. The inspection and repair will be performed at no cost to you.

How long will it take?

It will take approximately one and a half hours to complete the inspection and repair; however, your Mazda dealer may need your vehicle for a longer period of time. Mazda will provide alternate transportation, if needed, when your vehicle is at an authorized Mazda dealership for a recall repair. Schedule an appointment with an authorized Mazda dealer so they can discuss and accommodate your needs.

What should you do?

Mazda is concerned about your safety, and we encourage you to contact any authorized Mazda dealer to schedule an appointment to have your Mazda vehicle inspected and repaired as soon as possible. You do not need to bring this notice to the dealer, but it may assist in the check-in process. Until the inspection/repair is performed, when parking your vehicle, please be sure to depress the brake pedal and then firmly pull the parking brake. Move the shift lever to P, if equipped with an automatic transmission, or, if equipped with a manual transmission, move the gearshift lever to either 1st or Reverse gear. Turn the ignition "Off" then slowly release the brake pedal.

What if you already paid for repair related to this concern?

If you have already paid for repairs due to conditions similar to this recall campaign prior to receiving this notice, you may be eligible for reimbursement of reasonable repair expenses based on Mazda's repair standards. For vehicles purchased in the USA, Please visit www.mazdareimbursement.com and enter your Vehicle Identification Number (VIN). Follow the online screen prompts to enter the relevant information to submit your claim. For further questions or if you do not have access to apply online, contact the Mazda Customer Experience Center at 1-800-222-5500, Option #6. For vehicles purchased in U.S. Territories, please contact the U.S. Territory where your vehicle was originally sold.

Where is the closest Mazda dealer?

In the USA, to locate your nearest Mazda dealer, visit our website www.MazdaRecallInfo.com, or call our Customer Experience Center at (800) 222-5500, option #6. If your vehicle is in a U.S. Territory, please contact Customer Service where your vehicle is located.

Puerto Rico: www.mazdapr.com, or call (787) 620-7546.

Saipan: www.carssaipan.com, or call (670) 322-7133.

Guam: www.carsguam.com, or call (671) 648-2277.

Moved or no longer own this vehicle?

If you have moved or no longer own your Mazda vehicle, please complete and mail the Information Change Card in the postage paid envelope as soon as possible. This enables us to update our records and notify the current owner. Federal law requires that any vehicle lessor receiving this recall notice must forward a copy of this notice to the lessee within ten days.

Still have questions?

If you have any questions regarding this campaign, In the USA, visit our website www.MazdaRecallInfo.com, or call our Customer Experience Center at (800) 222-5500, option #6. If your vehicle is in a U.S. Territory, please contact Customer Service where your vehicle is located.

Puerto Rico: www.mazdapr.com, or call (787) 620-7546.

Saipan: www.carssaipan.com, or call (670) 322-7133.

Guam: www.carsguam.com, or call (671) 648-2277.

If Mazda or its dealers do not repair the defect free of charge and within a reasonable amount of time, you may notify the Administrator of the National Highway Traffic Safety Administration, 1200 New Jersey Ave., SE., Washington, DC 20590; or call the toll-free Vehicle Safety Hotline at 1-888-327-4236 (TTY: 1-800-424-9153); or go to <http://www.safercar.gov>.

Important Information

As a reminder, you can always go to www.MazdaRecallInfo.com and enter your VIN to view recalls and service campaigns that apply to your vehicle as well as register to receive future recall alerts. You can also sign up for recall notifications in the MyMazda app on your smartphone.

Your safety is our first priority at Mazda. We actively work to improve our products and search for solutions to improve your ownership experience. We apologize for any inconvenience this recall may have caused you.

Sincerely,

Mazda North American Operations

*Para información en español, visite www.MazdaSeguridad.com o llame a nuestro **Centro de Experiencia para el Consumidor al (800) 222-5500, opción #8** para hablar con un representante en español.*