

# Compliance Recall

## Code: 69T7



<b>Subject</b>	<b>Head Curtain Airbags</b>
<b>Release Date</b>	January 05, 2018
<b>Affected Vehicles</b>	<b>U.S.A. : Certain 2018 MY Audi A5 Coupe</b> <i>Check Campaigns/Actions screen in Elsa on the day of repair to verify that a VIN qualifies for repair under this action. Elsa is the <u>only</u> valid campaign inquiry &amp; verification source.</i> <ul style="list-style-type: none"><li>✓ Campaign status must show "open."</li><li>✓ If Elsa shows other open action(s), inform your customer so that the work can also be completed at the same time the vehicle is in the workshop for this campaign.</li></ul>
<b>Problem Description</b>	A head curtain airbag may not unfold properly from the A-pillar during deployment. In a crash where the head curtain airbag deploys, this may result in reduced airbag protection and could increase the risk of injury to vehicle occupants. This makes the head curtain airbags noncompliant with Federal Motor Vehicle Safety Standard No. 226 – Ejection Mitigation.
<b>Corrective Action</b>	Remove excess fabric from the head curtain airbags, along with the paper sleeve on the upper part of the A-pillar.
<b>Parts Information</b>	Parts will be allocated prior to owner notification. If allocated parts have been used and your dealership is at the weekly Upper Order Limit, please submit the backordered sales document number to <a href="mailto:upperorderlimits@audi.com">upperorderlimits@audi.com</a> to have additional parts released.
<b>Code Visibility</b>	On or about January 05, 2018, affected vehicles will be listed on the Inventory Vehicle Open Campaign Action report under My Dealership Reports (found on <a href="http://www.accessaudi.com">www.accessaudi.com</a> & OMD Web). A list will not be posted for dealers who do not have any affected vehicles.  On or about January 05, 2018, this campaign code will show open on affected vehicles in Elsa.  On or about January 05, 2018, affected vehicles will be identified with this campaign code in the VIN Lookup tool at <a href="http://www.audiusa.com">www.audiusa.com</a> and on the NHTSA VIN lookup tool at <a href="http://www.safercar.gov">www.safercar.gov</a> .
<b>Owner Notification</b>	Owner notification will take place in January 2018. Owner letter examples are included in this bulletin for your reference.
<b>Additional Information</b>	<b>Please alert everyone in your dealership about this action, including Sales, Service, Parts and Accounting personnel. Contact Warranty if you have any questions.</b>  <b>IMPORTANT REMINDER ON VEHICLES AFFECTED BY SAFETY &amp; COMPLIANCE RECALLS</b>  <b><u>New Vehicles in Dealer Inventory:</u> It is a violation of Federal law for a dealer to deliver a new motor vehicle or any new or used item of motor vehicle equipment (including a tire) covered by this notification under a sale or lease until the defect or noncompliance is remedied. By law, dealers must correct, prior to delivery for sale or lease, any vehicle that fails to comply with an applicable Federal Motor Vehicle Safety Standard or that contains a defect relating to motor vehicle safety.</b>  <b><u>Pre-Owned Vehicles in Dealer Inventory:</u> Dealers should not deliver any pre-owned vehicles in their inventory which are involved in a safety or compliance recall until the defect has been remedied.</b>  Dealers must ensure that every affected inventory vehicle has this campaign completed <u>before</u> delivery to consumers.

**Claim Entry Instructions**

After campaign has been completed, enter claim as soon as possible to help prevent work from being duplicated elsewhere. Attach the Elsa screen print showing action open on the day of repair to the repair order.

If customer refused campaign work:

- ✓ U.S. dealers: Submit the request through Audi Warranty Online under the Campaigns/Update option.

<b>Service Number</b>	69T7							
<b>Damage Code</b>	0099							
<b>Parts Vendor Code</b>	002							
<b>Claim Type</b>	Sold vehicle: 7 10 Unsold vehicle: 7 90							
<b>Causal Indicator</b>	Mark labor as causal.							
<b>Vehicle Wash/Loaner</b>	Do not claim wash/loaner under this action							
<b>Criteria I.D.</b>	F5							
	<p>Check left and right head curtain airbag.            Labor operation: 7057 20 99 50 T.U.</p> <table border="1"> <thead> <tr> <th>Quantity</th> <th>Part Number</th> <th>Description</th> </tr> </thead> <tbody> <tr> <td>2.00</td> <td>8V0867276A</td> <td>A-Pillar Clip</td> </tr> </tbody> </table> <p>-AND (if required)-            Remove material from left head curtain airbag            Labor operation: 6966 50 99 10 T.U.</p> <p>-AND (if required)-            Remove material from right head curtain airbag            Labor operation: 6966 51 99 10 T.U.</p>		Quantity	Part Number	Description	2.00	8V0867276A	A-Pillar Clip
Quantity	Part Number	Description						
2.00	8V0867276A	A-Pillar Clip						

## Customer Letter Example (USA)

<MONTH YEAR>

<CUSTOMER NAME>

<CUSTOMER ADDRESS>

<CUSTOMER CITY STATE ZIPCODE>

**This notice applies to your vehicle:** <VIN>

**NHTSA:** 17V822

**Subject: Compliance Recall 69T7 – Head Curtain Airbags  
Certain 2018 Model Year Audi A5 Coupe**

Dear Audi Owner,

This notice is sent to you in accordance with the National Traffic and Motor Vehicle Safety Act. Audi has decided that certain 2018 model year Audi A5 coupe vehicles fail to conform to Federal Motor Vehicle Safety Standard No. 226 – Ejection Mitigation. Our records show that you are the owner of a vehicle affected by this action.

<b>What is the issue?</b>	A head curtain airbag may not unfold properly from the A-pillar during deployment. In a crash where the head curtain airbag deploys, this may result in reduced airbag protection and could increase the risk of injury to vehicle occupants.
<b>What will we do?</b>	To correct this noncompliance, your authorized Audi dealer will remove excess fabric from the head curtain airbags, along with the paper sleeve on the upper part of the A-pillar. This work will take about one hour to complete and will be performed for you free of charge. Please keep in mind that your dealer may need additional time for the preparation of the repair, as well as to accommodate their daily workshop schedule.
<b>What should you do?</b>	Please contact your authorized Audi dealer without delay to schedule this recall repair. For your convenience, you can also visit <a href="http://www.audiusa.com">www.audiusa.com</a> and click on the “Find a Dealer” link to locate a dealer near you and schedule this service.
<b>Lease vehicles and address changes</b>	If you are the lessor and registered owner of the vehicle identified in this action, the law requires you to forward this letter immediately via first-class mail to the lessee within ten (10) days of receipt. If you have changed your address or sold the vehicle, please fill out the enclosed prepaid Owner Reply card and mail it to us so we can update our records.
<b>Can we assist you further?</b>	If your authorized Audi dealer fails or is unable to complete this work free of charge within a reasonable time, please contact Audi Customer Experience at 1-800-253-2834 or via our “Contact Us” page at <a href="http://www.audiusa.com">www.audiusa.com</a> .
<b>Checking your vehicle for open Recalls and Service Campaigns</b>	To check your vehicle's eligibility for repair under this or any other recall/service campaign, please visit the <b>Recall/Service Campaign Lookup</b> tool at <a href="http://www.audiusa.com">www.audiusa.com</a> and enter your Vehicle Identification Number (VIN).

If you still cannot obtain satisfaction, you may file a complaint with: The Administrator, National Highway Traffic Safety Administration, 1200 New Jersey Avenue, SE., Washington, DC 20590; or call the toll-free Vehicle Safety Hotline at 1-888-327-4236 (TTY: 1-800-424-9153); or go to <http://www.safercar.gov>.

We apologize for any inconvenience this matter may cause; however we are taking this action to help ensure your safety and continued satisfaction with your vehicle.

Sincerely,

Audi Customer Protection





**NOTE**

Damages resulting from improper repair or failure to follow these work instructions are the dealer's responsibility and are not eligible for reimbursement under this action.

**Required Parts**

<u>Criteria</u>	<u>Quantity</u>	<u>Part Number</u>	<u>Part Description</u>
F5	2	8V0867276A	A-Pillar Clip

**Required Tools**

 <p>Trim Removal Wedge -3409- (or equivalent)</p>	 <p>Omega Clip Tool -T40280- (or equivalent)</p>
 <p>Metric Ruler</p>	 <p>Rounded Tip "Safety" Scissors</p>
 <p>Pry lever -80-200- (or equivalent)</p>	

## Repair Instruction

### Section A - Check for Previous Repair

Applicable criteria ID(s)	Campaign/Action Status
01 ← <b>2</b>	Open ← <b>1</b>

**EXAMPLE**

- Enter the VIN in Elsa and proceed to the “Campaign/Action” screen.

#### TIP

On the date of repair, print this screen and keep a copy with the repair order.

- Confirm the Campaign/Action is open <arrow 1>. If the status is closed, no further work is required.
- Note the Applicable Criteria ID <arrow 2> for use in determining the correct work to be done and corresponding parts associated.

**Proceed to Section B**

## Section B – Repair Procedure

### NOTE

- Damages resulting from improper repair or failure to follow these work instructions are the dealer's responsibility and are not eligible for reimbursement under this action.
- This procedure must be read in its entirety prior to performing the repair.
- Due to variations in vehicle equipment and options, the steps/illustrations in this work procedure may not identically match all affected vehicles.
- Diagnosis and repair of pre-existing conditions in the vehicle are not covered under this action.
- When working during extreme temperatures, it is recommended that the vehicle be allowed to acclimate inside the shop to avoid temperature-related component damage/breakage.

### NOTE

The procedures shown for head curtain airbag repair illustrate the driver side. Repeat the steps for the passenger side.

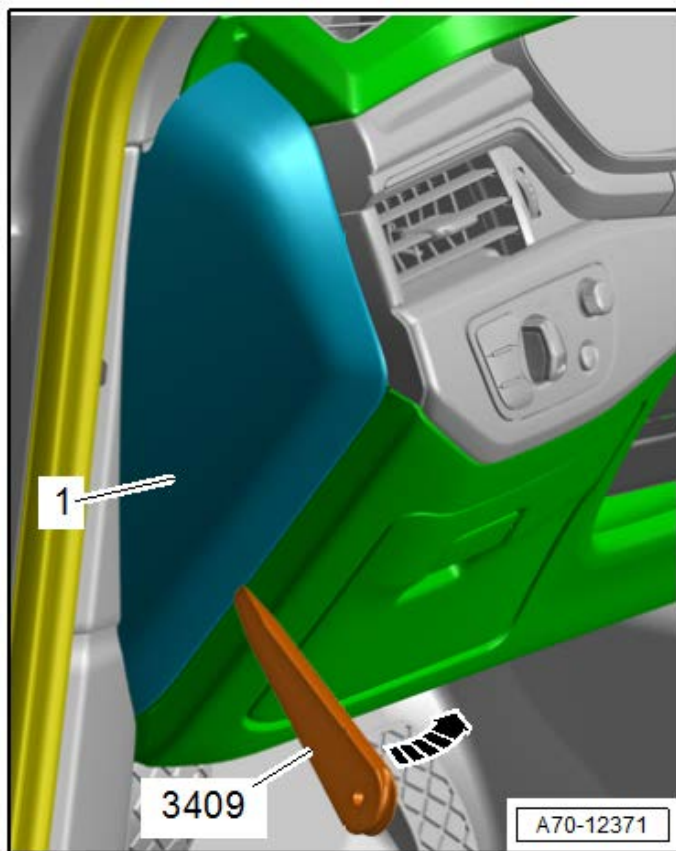

- Pry off the instrument panel side cover <1> using the -3409- in direction of <arrow>.

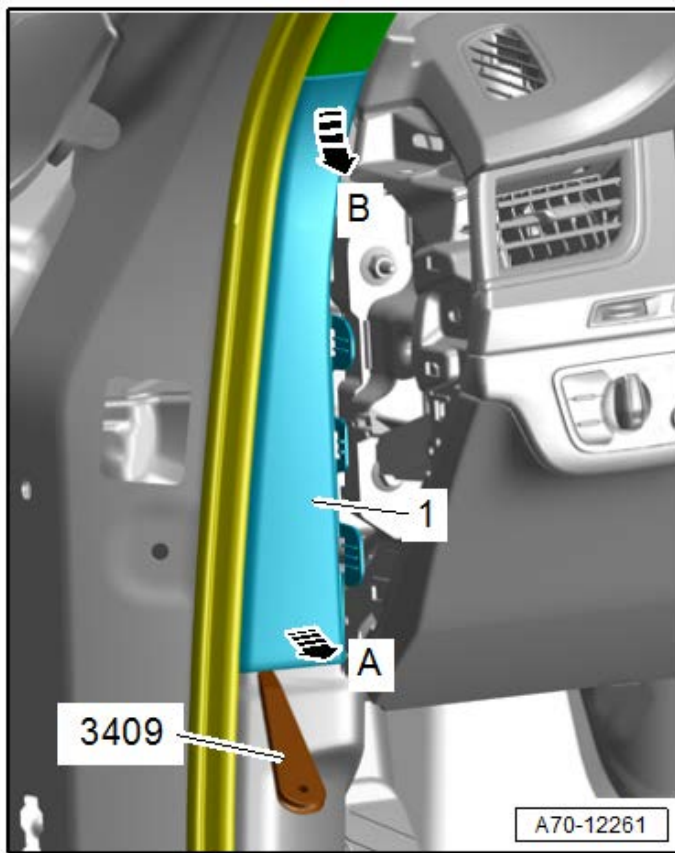

- Unclip the A-pillar gap cover <1> using the -3409- in direction of <arrow A> and disengage at the A-pillar upper trim panel in direction of <arrow B>.

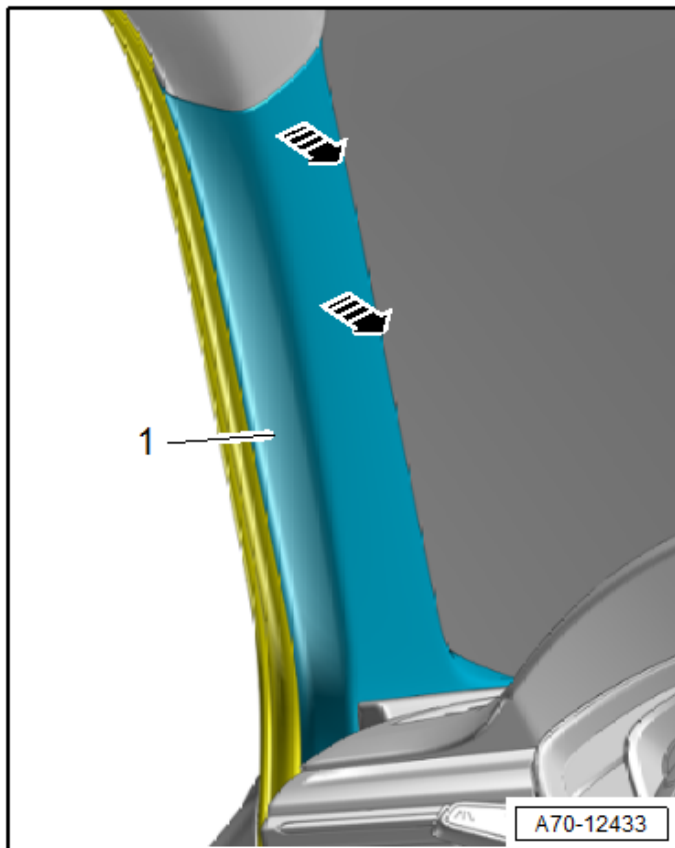

- Free up the A-pillar trim panel <1> in the door seal area.
- Detach the A-pillar trim panel using the -3409- up to the first retainer <arrows>.

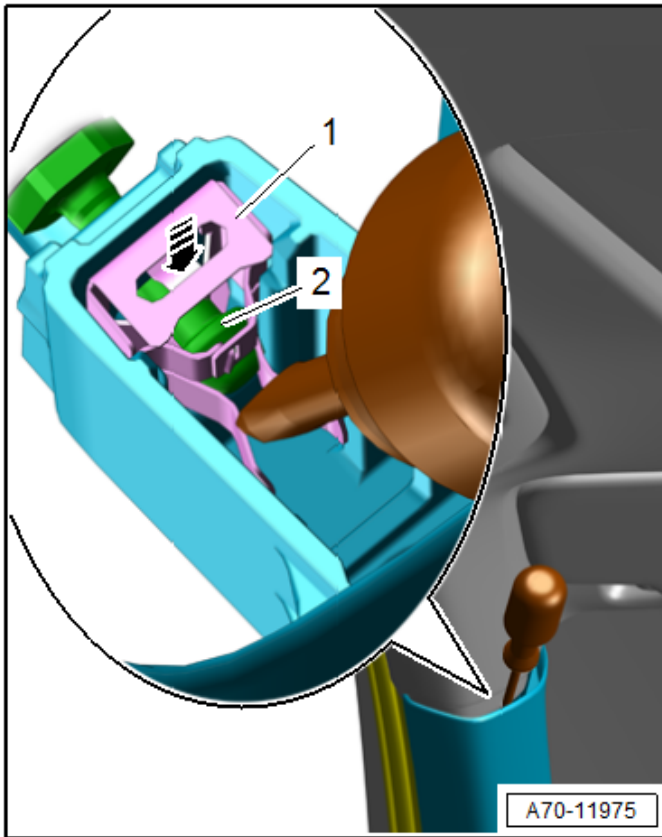

- Place a flat-head screwdriver at the position shown on the clip.
- Push the clip downward with the flat-head screwdriver into the trim panel <arrow>. This will move the clip hooks from the pin head <2>.

**NOTE**

- The A-pillar clips <1> may be damaged during removal.
- The A-pillar clip must be replaced even if was not damaged during removal.
- Take care that the A-pillar trim is not damaged during removal.

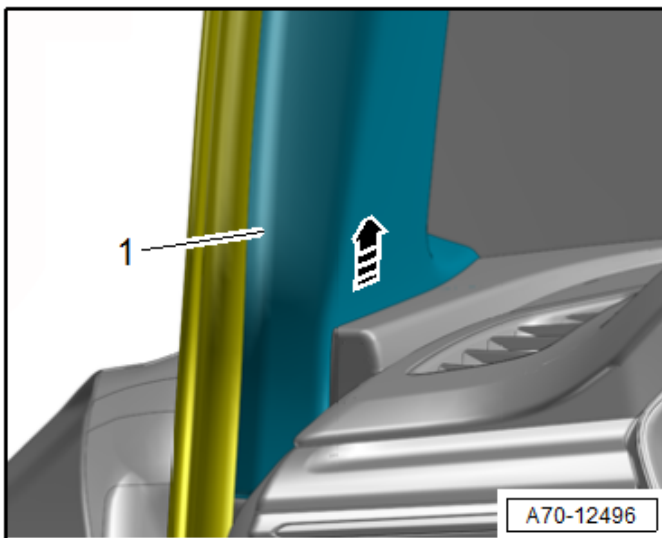

- Carefully remove the trim panel <1> upward out of the instrument panel in the direction of <arrow>.
- If equipped, disconnect the connector for the treble speaker.





- Check for presence of tape <A> and excess material <B>.
  - If tape <A> and excess material <B> are not present, **proceed to Section C.**
  - If tape <A> and /or excess material <B> are present, **proceed to the next step.**

**⚠ WARNING**

**Risk to occupant**

Do not remove the tape located on the lower section of the head curtain airbag.

**! NOTE**

The procedures shown for head curtain airbag repair illustrate the driver side. Repeat the steps for the passenger side.

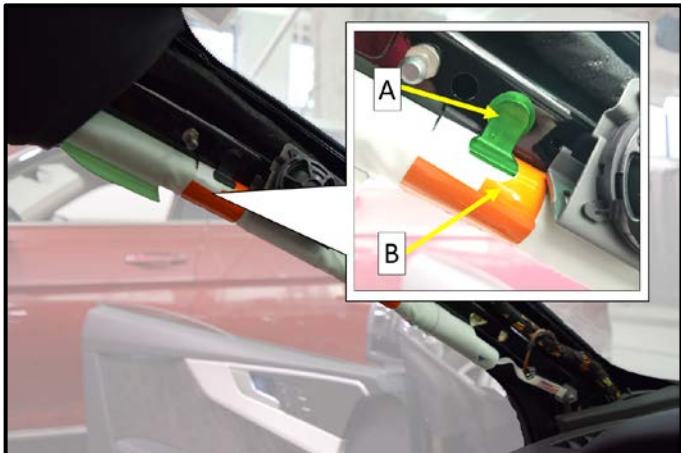

- Remove and discard clip <A> and tape <B> from the head curtain airbag.

**⚠ DANGER**

**Risk to occupant**

- Do not cut the airbag material when removing tape <B>.
- All of the tape must be removed from the head curtain airbag.

**! NOTE**

- The tape <B> is perforated and should be able to be removed without using any tools.
- If the tape cannot be torn, used curved tip scissors to cut off the tape.

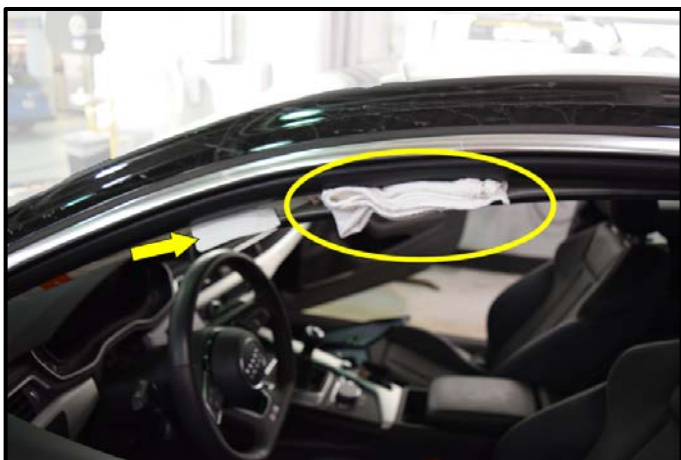

- Pull the headliner down slightly and place a clean folded shop rag <circle> between the roof and the headliner as shown.
- Pull the head curtain airbag material out slightly <arrow>.

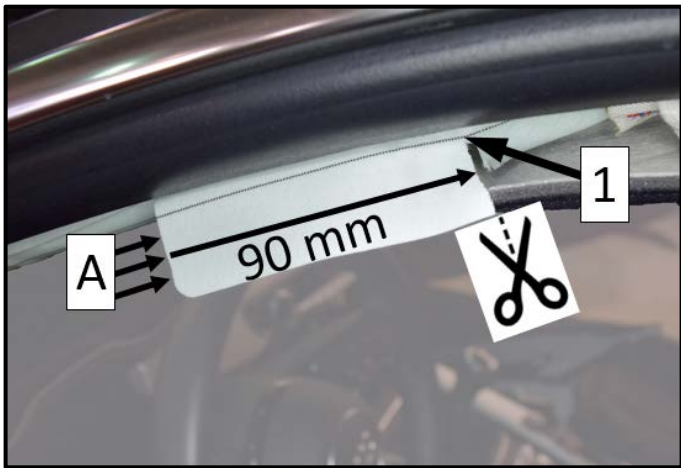

**⚠ WARNING**

**Risk to occupant**

Scissors with a curved tip must be used to avoid puncturing the head curtain airbag.

- Measure 90mm from leading edge <A> and carefully cut the fabric up to the dotted line <1>.

**⚠ CAUTION**

Do not cut the headliner.

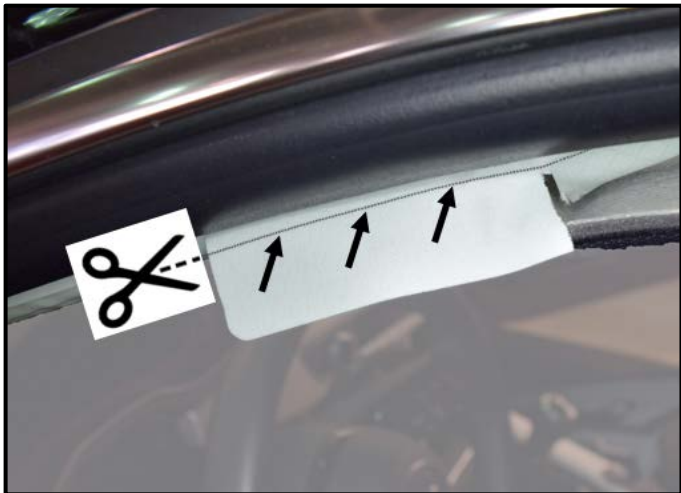

**⚠ WARNING**

**Risk to occupant**

Scissors with a curved tip must be used to avoid puncturing the head curtain airbag.

- Carefully cut along the dotted line <arrows> up to the previously made cut and remove the excess fabric.

**⚠ CAUTION**

Do not cut the headliner.

**Proceed to Section C.**

## Section C – Reassembly

### NOTE

The A-pillar clip must be replaced even if was not damaged during removal.

- Install new clip into the A-pillar trim.

Part Number	Part Description
8V0 867 276 A	A-Pillar Clip

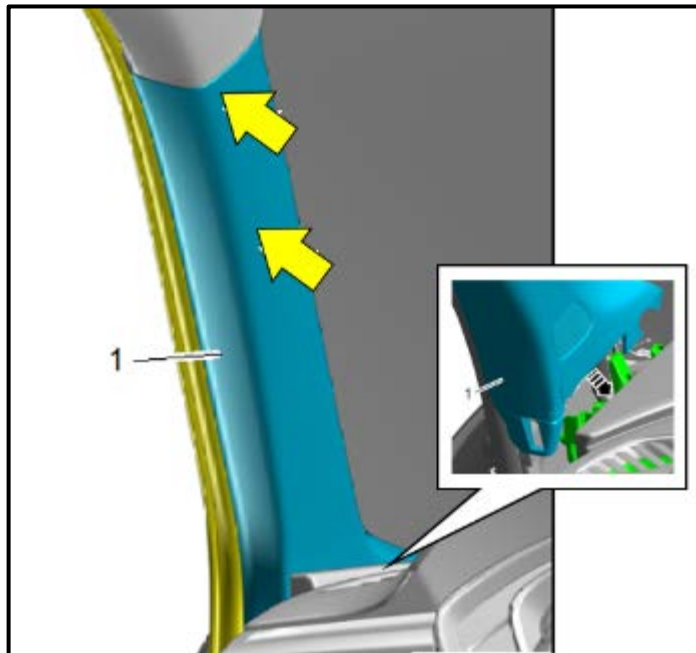

- If needed, remove trim clips from the body using Omega Clip Tool -T40280- (or equivalent) and install into the trim panel.
- Insert the A-pillar trim panel <1> in the mount on the instrument panel <arrow>.
- If equipped, connect speaker.
- Install A-pillar trim in <direction of arrows>.
- Install A-pillar gap cover.
- Install instrument panel side cover.
- Verify all seals are installed properly.
- Perform on both sides.

**Proceed to Section D.**

## Section D – Campaign Completion Stamp

I certify that this campaign  
has been performed in strict  
accordance with the applicable  
Audi repair procedure.

SAGA Code: \_\_\_\_\_

Technician: \_\_\_\_\_

Date: \_\_\_\_\_

Item#: AUD4927ENG

- Once the campaign has been completed, the technician should stamp the repair order.
- Stamps are available for ordering through the Compliance Label Ordering Portal.
- **Proceed to Section E.**

## Section E - Parts Return/Disposal

Properly store (retain), destroy or dispose of removed parts in accordance with all state/province and local requirements, unless otherwise indicated and/or requested through the Warranty Parts Portal (WPP).