 <b>HYUNDAI</b> <b>Technical Service Bulletin</b>	GROUP <b>RECALL</b>	NUMBER <b>17-01-074</b>
	DATE <b>DECEMBER, 2017</b>	MODEL(S) <b>SANTA FE SPORT (AN)</b>

**SUBJECT:** 2018 SANTA FE SPORT (AN) CURTAIN AIRBAG REPLACEMENT  
(RECALL CAMPAIGN 171)

**\* IMPORTANT**

**\*\*\* Dealer Stock and Retail Vehicles \*\*\***

Dealers must perform this Recall Campaign on all affected vehicles prior to customer retail delivery and whenever an affected vehicle is in the shop for any maintenance or repair.

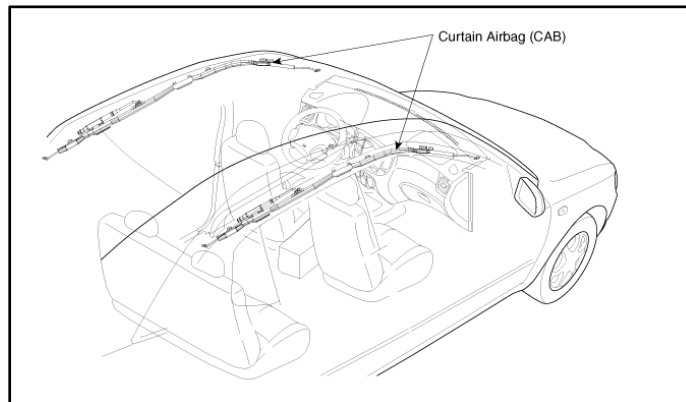

When a vehicle arrives at the service department, access Hyundai Motor America’s “Warranty Vehicle Information” screen via WEBDCS to identify open Campaigns.

**Description:** Certain 2018MY Santa Fe Sport (AN) vehicles may contain curtain airbag modules with an inflator that could potentially not meet specification. If the curtain airbag inflator does not meet specification, the airbag may not inflate as designed in a collision. A failure of the curtain airbags to properly inflate could increase the risk of injury to the driver and the passengers in a side impact/rollover collision. This bulletin describes the procedure to replace the driver’s side and passenger’s side curtain airbags.

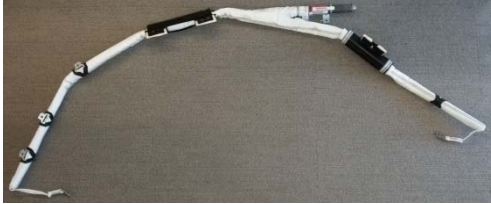

**Applicable Vehicles:**  
**2018MY Santa Fe Sport (AN) vehicles produced by Kia Motors Manufacturing Georgia (VIN beginning with a “5XY”) from September 5, 2017 through November 30, 2017.**  
**2018MY Santa Fe Sport (AN) vehicles produced by Hyundai Motor Manufacturing Alabama (VIN beginning with a “5NM”) from November 2, 2017 through November 17, 2017.**

**Parts Information:**

Part Name	Part Number	QTY.	Figure
Curtain Air Bag Module, LH	85010-4Z000QQH	1	
Curtain Air Bag Module, RH	85020-4Z000QQH	1	
Clip-Trim Mtg (A-pillar tether clip)	85815-C1000QQH	2	

**Tools & Equipment Required:**

Tool Name	Image	Remarks
Clip/Trim Tool		

**Warranty Information:**

Model	Op Code	Operation	Op Time	Causal Part	Nature Code	Causal Code
Santa Fe Sport (AN) KMMG Prod. (VIN starts with "5XY")	71CG13R0	Curtain Airbag Replacement (Both Sides)	2.1 M/H	85010-4Z000	I3R	ZZ3
Santa Fe Sport (AN) HMMA Prod. (VIN starts with "5NM")	71CG13R1	Curtain Airbag Replacement (Both Sides)	2.1 M/H	85010-4Z000	I3R	ZZ3

**NOTE 1:** Submit Claim on Campaign Claim Entry Screen

**NOTE 2:** If a part is found in need of replacement while performing Recall 171 and the affected part is still under warranty, submit a separate claim using the same Repair Order.

**Service Procedure:**

1.
  - a. Record the customer's radio presets.
  - b. Wear a set of clean rubber gloves before starting the procedure.
  - c. Place the ignition key in the 'OFF' position.



2. Open the tailgate (A).



3. Remove the luggage covering mat (B), luggage floor front board (C), luggage tray board (D), jack tool set (E), luggage floor box (F) following procedures detailed in the 2013-2018 Santa Fe Sport Service Manual (Body (Interior and Exterior)) section.

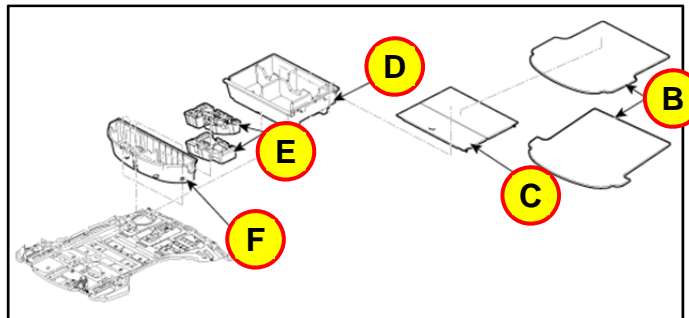

4. Move the driver seat and passenger seat to the foremost positions and lower the headrests on the second row seat.

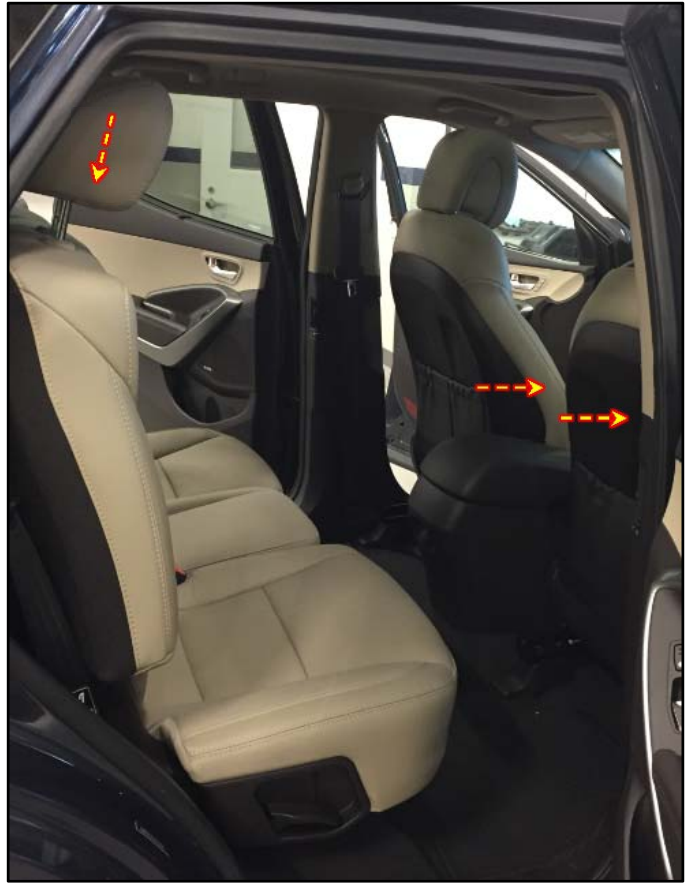

5. Position the second row seats to the foremost position and fold down the second rows.

**NOTE:** For the vehicles with the non-sliding second row seats, remove the seat track mounting covers (G) and the mounting bolts (H) and position the second rows to the foremost position manually.

**Tightening torque:**

**Bolt : 16.7 ~ 25.5 N.m (1.7 ~ 2.6 kgf.m, 12.3 ~ 18.8 lb-ft)**

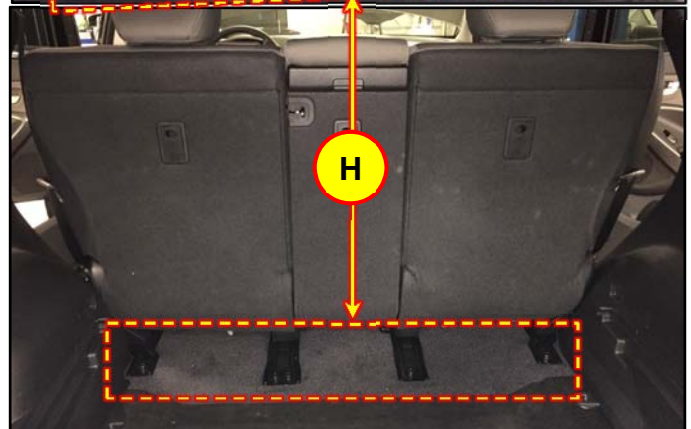
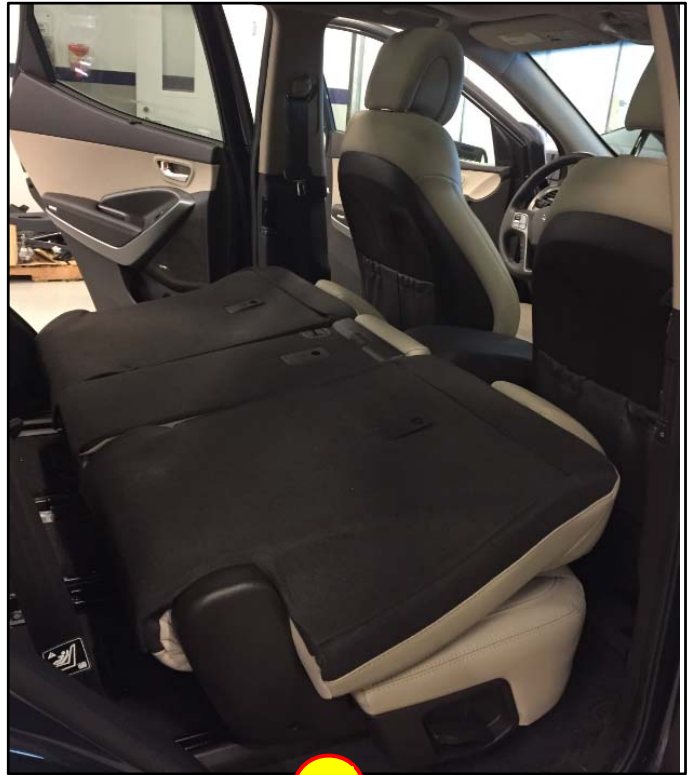

6. Tilt the front seats as far back as possible and remove both the driver and passenger headrests (I).

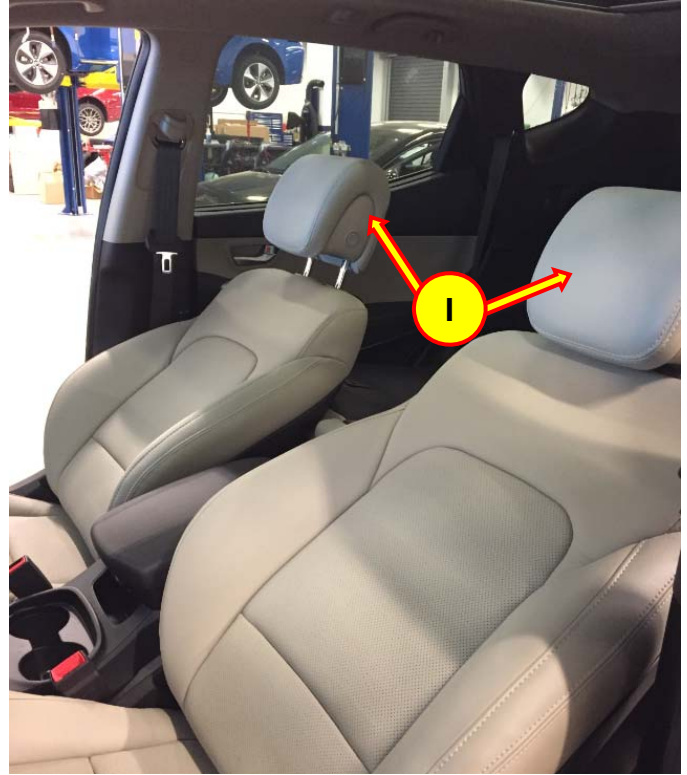

7. Open the hood and disconnect the Negative (-) terminal (J) from the battery.

**NOTICE**

**NOTE:** Wait at least 3 minutes before proceeding to make sure voltage is bled off.

**⚠ WARNING**

Not removing the Negative (-) terminal from the battery may result in accidental airbag deployment and possible physical injury.



8. Carefully remove the body-side weather stripping and A-pillar (K), B-pillar (L), and C-pillar trim (M) panels for the passenger and driver sides following procedures detailed in the 2013-2018 Santa Fe Sport Service Manual (Body (Interior and Exterior)) section.

**NOTICE**

**NOTE: A-pillar tether clips MUST be replaced prior to reinstalling the A pillar trims.**

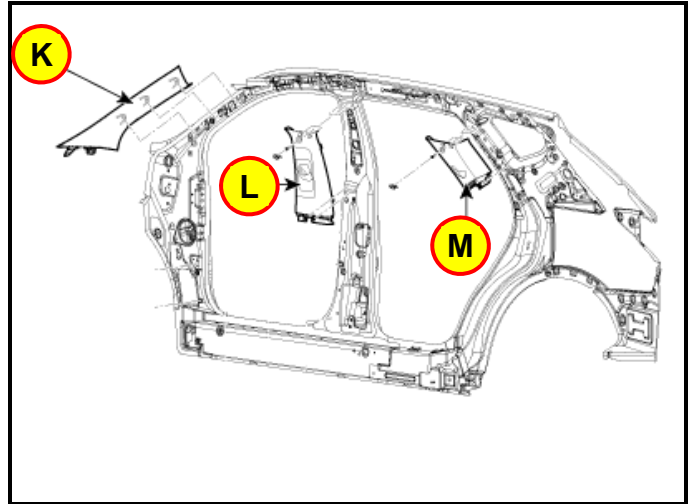

9. Follow the removal procedures detailed in the 2013-2018 Santa Fe Sport Service Manual (Body (Interior and Exterior)) section to remove the roof trim assembly.

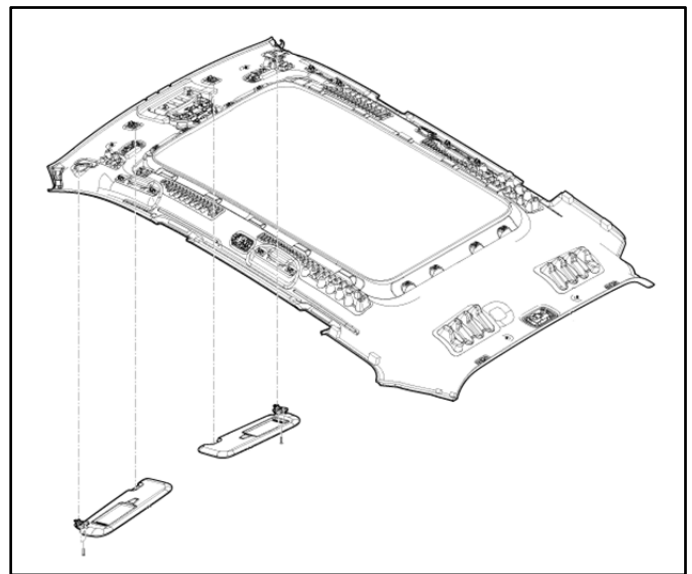

10. Place a protective cover over the dash to avoid permanent markings/scuffing on the dash panel from the corner of the headliner edges.  
Lower the headliner (N).

**NOTICE**

Use caution not to lean or crease the headliner while replacing the curtain airbag modules.





11. Carefully disconnect the driver curtain airbag harness connector by lifting up the locking tab (O) first, then separating the squib connector (P). Repeat for the passenger curtain airbag.

**CAUTION**

Be **EXTREMELY** careful when removing the locking tab. If the locking tab breaks, the entire airbag harness will need to be replaced.

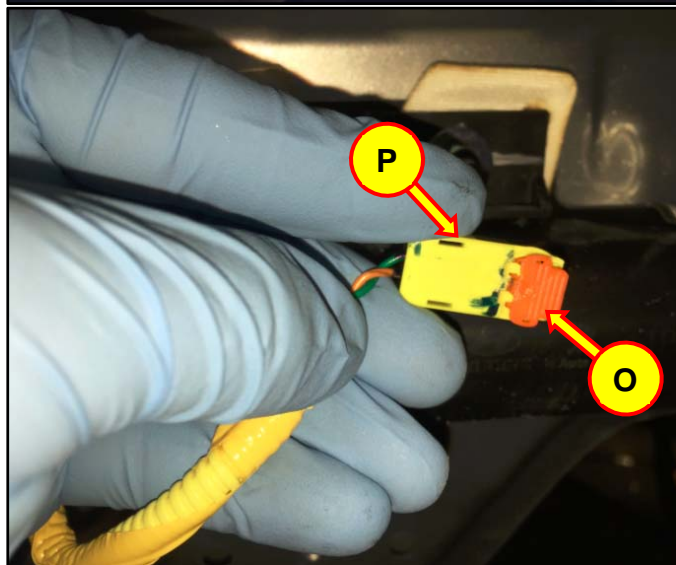
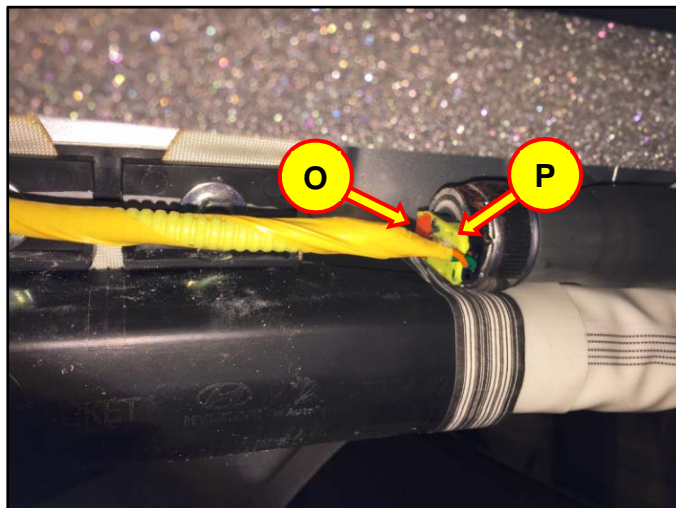

12. Remove all mounting bolts and nuts from the passenger and driver side curtain airbag assemblies and remove the curtain airbag assemblies from the vehicle.

**Tightening torque:**

**Bolt : 7.8 ~ 11.8 N.m (0.8 ~ 1.2 kgf.m, 5.8 ~ 8.7 lb-ft)**

**Nut : 3.9 ~ 5.9 N.m (0.4 ~ 0.6 kgf.m, 2.9 ~ 4.3 lb-ft)**

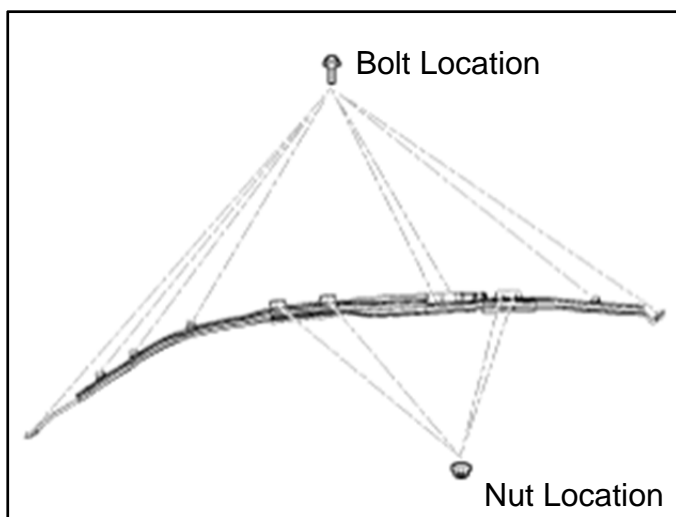

13. Cut the fabric of the front 4 attachment points (Q) on the original passenger and driver side curtain airbag assemblies that have been removed from the vehicle.

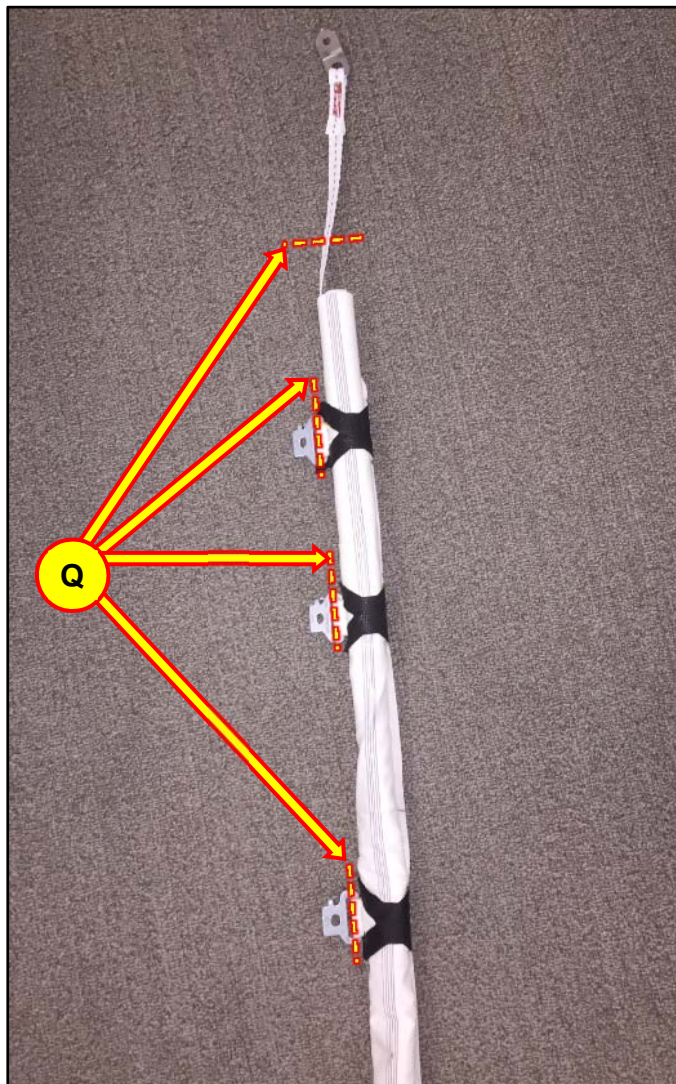

14. Install the new passenger and driver curtain airbag assemblies in the vehicle following the procedures detailed in the 2013-2018 Santa Fe Sport Service Manual (Restraint) section. Torque each nut and bolt to the spec shown below.

**Tightening torque:**

**Bolt : 7.8 ~ 11.8 N.m (0.8 ~ 1.2 kgf.m, 5.8 ~ 8.7 lb-ft)**

**Nut : 3.9 ~ 5.9 N.m (0.4 ~ 0.6 kgf.m, 2.9 ~ 4.3 lb-ft)**

**⚠ WARNING**

**Never twist the curtain airbag assembly during installation. If the curtain airbag assembly is twisted, it may not operate as designed.**

15. Remove the screw (R) on the A-pillar trim (S) and slide the locking tab (T) out in order to replace the A pillar tether clip (U).

**NOTICE**

**NOTE: A-pillar tether clips MUST be replaced prior to reinstalling the A pillar trims.**

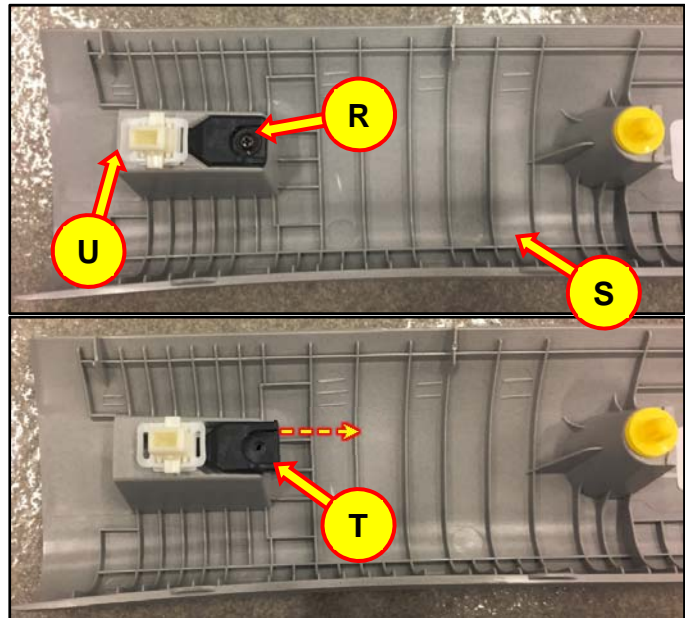

16. Reinstall the remaining components in reverse order of removal per the 2013-2018 Santa Fe Sport Service Manual (Body (Interior and Exterior)).
17. Reconnect the negative battery cable after all the components have been re-installed to the vehicle.
18. Program the customer's AM, FM, and the XM radio preset stations.
19. Confirm there is no illuminated airbag light prior to returning the vehicle to the customer.