



# Safety Recall

## Code: 20AQ

<b>Subject</b>	<b>Fuel Tank</b>
<b>Release Date</b>	January 09, 2018
<b>Affected Vehicles</b>	<b>U.S.A. &amp; CANADA: 2018 MY Volkswagen Atlas</b> <i>Check Campaigns/Actions screen in Elsa on the day of repair to verify that a VIN qualifies for repair under this action. Elsa is the <u>only</u> valid campaign inquiry &amp; verification source.</i> <ul style="list-style-type: none"><li>✓ Campaign status must show “open.”</li><li>✓ If Elsa shows other open action(s), inform your customer so that the work can also be completed at the same time the vehicle is in the workshop for this campaign.</li></ul>
<b>Problem Description</b>	Fuel may leak from the fuel tank. Leaking fuel, in the presence of an ignition source, may result in a fire.
<b>Corrective Action</b>	Replace fuel tank.
<b>Precautions</b>	If a customer smells a fuel odor or sees a fuel puddle under the vehicle, they are advised to contact an authorized Volkswagen dealer right away.
<b>Parts Information</b>	Due to the small number of affected vehicles, parts allocation will be limited to dealers with affected inventory. If you need to order a fuel tank to support this recall repair, please contact Parts Special Services with the VIN.
<b>Code Visibility</b>	On or about January 09, 2018, affected vehicles will be listed on the Inventory Vehicle Open Campaign Action report under My Dealership Reports (found on <a href="http://www.vwhub.com">www.vwhub.com</a> & OMD Web). A list will not be posted for dealers who do not have any affected vehicles.  On or about January 09, 2018, this campaign code will show open on affected vehicles in Elsa.  On or about January 09, 2018, affected vehicles will be identified with this campaign code in the VIN Lookup tool at <a href="http://www.vw.com">www.vw.com</a> and on the NHTSA VIN lookup tool at <a href="http://www.safercar.gov">www.safercar.gov</a> .
<b>Owner Notification</b>	Owner notification will take place in January 2018. Owner letter examples are included in this bulletin for your reference.
<b>Additional Information</b>	<b>Please alert everyone in your dealership about this action, including Sales, Service, Parts and Accounting personnel. Contact Warranty if you have any questions.</b>  <b>IMPORTANT REMINDER ON VEHICLES AFFECTED BY SAFETY &amp; COMPLIANCE RECALLS</b>  <b><u>New Vehicles in Dealer Inventory:</u> It is a violation of Federal law for a dealer to deliver a new motor vehicle or any new or used item of motor vehicle equipment (including a tire) covered by this notification under a sale or lease until the defect or noncompliance is remedied. By law, dealers must correct, prior to delivery for sale or lease, any vehicle that fails to comply with an applicable Federal Motor Vehicle Safety Standard or that contains a defect relating to motor vehicle safety.</b>  <b><u>Pre-Owned Vehicles in Dealer Inventory:</u> Dealers should not deliver any pre-owned vehicles in their inventory which are involved in a safety or compliance recall until the defect has been remedied.</b>  Dealers must ensure that every affected inventory vehicle has this campaign completed <u>before delivery to consumers</u> .  Fill out and affix Campaign Completion Label (CAMP 010 000) after work is complete. Labels can be ordered at no cost via the Compliance Label Ordering portal at <a href="http://www.vwhub.com">www.vwhub.com</a> .

### Claim Entry Instructions

After campaign has been completed, enter claim as soon as possible to help prevent work from being duplicated elsewhere. Attach the Elsa screen print showing action open on the day of repair to the repair order.

If customer refused campaign work:

- ✓ U.S. dealers: Submit request via WISE under the *Campaigns/Update/Recall Closure* option.
- ✓ Canada dealers: Fax repair order to Warranty at (905) 428-4811.

<b>Service Number</b>	20AQ																																					
<b>Damage Code</b>	0099																																					
<b>Parts Vendor Code</b>	WWO																																					
<b>Claim Type</b>	Sold vehicle: 7 10 Unsold vehicle: 7 90																																					
<b>Causal Indicator</b>	Mark FUEL TANK as causal part*																																					
<b>Vehicle Wash/Loaner</b>	Do not claim wash/loaner under this action																																					
<b>Criteria I.D.</b>	01																																					
	<p>Replace fuel tank.</p> <p>Labor operation:      2010 19 99                                  320 T.U.</p> <table border="1" style="width: 100%; border-collapse: collapse;"> <thead> <tr> <th style="text-align: center;">Quantity</th> <th style="text-align: center;">Part Number</th> <th style="text-align: left;">Description</th> </tr> </thead> <tbody> <tr> <td style="text-align: center;">1.00</td> <td>3QF201055F</td> <td>Fuel Tank*</td> </tr> <tr> <td style="text-align: center;">1.00</td> <td>1J0919133B</td> <td>Seal Ring</td> </tr> <tr> <td style="text-align: center;">2.00</td> <td>N 10699801</td> <td>Bolt - Tank filler neck</td> </tr> <tr> <td style="text-align: center;">1.00</td> <td>N 10628401</td> <td>Bolt - Trailing arm to bearing housing</td> </tr> <tr> <td style="text-align: center;">4.00</td> <td>N 90936901</td> <td>Bolt - Seat Frame to Body</td> </tr> <tr> <td style="text-align: center;">4.00</td> <td>N 90994201</td> <td>Rivet</td> </tr> <tr> <td style="text-align: center;">6.00</td> <td>N 91159101</td> <td>Bolt - Fuel Tank</td> </tr> <tr> <td style="text-align: center;">1.00</td> <td>N 91268601</td> <td>Bolt - Trailing arm to bearing housing</td> </tr> <tr> <td style="text-align: center;">1.00</td> <td>WHT005749</td> <td>Bolt - Trailing arm to bearing housing</td> </tr> </tbody> </table> <p><b>OUTSIDE MATERIAL (Claim ONE time only)</b></p> <table border="1" style="width: 100%; border-collapse: collapse;"> <thead> <tr> <th style="text-align: center;">Quantity</th> <th style="text-align: left;">Description</th> <th style="text-align: center;">Amount</th> </tr> </thead> <tbody> <tr> <td style="text-align: center;">1 roll</td> <td>TAPE</td> <td style="text-align: center;">\$135</td> </tr> </tbody> </table>		Quantity	Part Number	Description	1.00	3QF201055F	Fuel Tank*	1.00	1J0919133B	Seal Ring	2.00	N 10699801	Bolt - Tank filler neck	1.00	N 10628401	Bolt - Trailing arm to bearing housing	4.00	N 90936901	Bolt - Seat Frame to Body	4.00	N 90994201	Rivet	6.00	N 91159101	Bolt - Fuel Tank	1.00	N 91268601	Bolt - Trailing arm to bearing housing	1.00	WHT005749	Bolt - Trailing arm to bearing housing	Quantity	Description	Amount	1 roll	TAPE	\$135
Quantity	Part Number	Description																																				
1.00	3QF201055F	Fuel Tank*																																				
1.00	1J0919133B	Seal Ring																																				
2.00	N 10699801	Bolt - Tank filler neck																																				
1.00	N 10628401	Bolt - Trailing arm to bearing housing																																				
4.00	N 90936901	Bolt - Seat Frame to Body																																				
4.00	N 90994201	Rivet																																				
6.00	N 91159101	Bolt - Fuel Tank																																				
1.00	N 91268601	Bolt - Trailing arm to bearing housing																																				
1.00	WHT005749	Bolt - Trailing arm to bearing housing																																				
Quantity	Description	Amount																																				
1 roll	TAPE	\$135																																				

## Customer Letter Example (USA)

<MONTH YEAR>

<CUSTOMER NAME>

<CUSTOMER ADDRESS>

<CUSTOMER CITY STATE ZIPCODE>

**This notice applies to your vehicle:** <VIN>

**NHTSA:** 17V766

**Subject: Safety Recall 20AQ – Fuel Tank  
2018 Model Year Volkswagen Atlas**

Dear Volkswagen Owner,

This notice is sent to you in accordance with the National Traffic and Motor Vehicle Safety Act. Volkswagen has decided that a defect, which relates to motor vehicle safety, exists in certain 2018 model year Volkswagen Atlas vehicles. Our records show that you are the owner of a vehicle affected by this action.

**What is the issue?** Fuel may leak from the fuel tank. Leaking fuel, in the presence of an ignition source, may result in a fire.

**What will we do?** To correct this defect, your authorized Volkswagen dealer will replace the fuel tank in your vehicle. This work will take about four hours to complete and will be performed for you free of charge.

**What should you do?** Please contact your authorized Volkswagen dealer without delay to schedule this recall repair. For your convenience, you can also visit [www.vw.com](http://www.vw.com) and click on the “Owners” link to locate a dealer near you and schedule this service online.

To help facilitate this repair, please have a quarter tank of fuel or less in your vehicle when you arrive for your scheduled appointment.

**Precautions you should take** If you smell fuel or notice a puddle of fuel beneath your vehicle, please contact your nearest authorized Volkswagen dealer right away.

**Lease vehicles and address changes** If you are the lessor and registered owner of the vehicle identified in this action, the law requires you to forward this letter immediately via first-class mail to the lessee within ten (10) days of receipt. If you have changed your address or sold the vehicle, please fill out the enclosed prepaid Owner Reply card and mail it to us so we can update our records.

**Can we assist you further?** If your authorized Volkswagen dealer fails or is unable to complete this work free of charge within a reasonable time, or if you should have any questions about this communication, please reach out to us using your preferred method of communication at [www.vw.com/contact](http://www.vw.com/contact) or by calling 1 800-893-5298. Our phone team is available Monday through Friday from 8AM to 10PM EST and Saturday from 9AM to 5PM EST.

**Checking your vehicle for open Recalls and Service Campaigns** To check your vehicle's eligibility for repair under this or any other recall/service campaign, please click on the **Look Up Recalls** link at [www.vw.com](http://www.vw.com) and enter your Vehicle Identification Number (VIN) into the **Recall/Service Campaign Lookup** tool.

If you still cannot obtain satisfaction, you may file a complaint with: The Administrator, National Highway Traffic Safety Administration, 1200 New Jersey Avenue, SE., Washington, DC 20590; or call the toll-free Vehicle Safety Hotline at 1-888-327-4236 (TTY: 1-800-424-9153); or go to <http://www.safercar.gov>.

We apologize for any inconvenience this matter may cause; however we are taking this action to help ensure your safety and continued satisfaction with your vehicle.

Sincerely,

Volkswagen Customer Protection

## Customer Letter Example (CANADA)

<MONTH YEAR>

<CUSTOMER NAME>

<CUSTOMER ADDRESS>

<CUSTOMER CITY STATE ZIPCODE>

**This notice applies to your vehicle:** <VIN>

**Subject: Safety Recall 20AQ – Fuel Tank  
2018 Model Year Volkswagen Atlas**

Dear Volkswagen Owner,

This notice is sent to you in accordance with the requirements of the Motor Vehicle Safety Act. Volkswagen has decided that a defect, which relates to motor vehicle safety, exists in certain 2018 model year Volkswagen Atlas vehicles. Our records show that you are the owner of a vehicle affected by this action.

**What is the issue?** Fuel may leak from the fuel tank. Leaking fuel, in the presence of an ignition source, may result in a fire.

**What will we do?** To correct this defect, your authorized Volkswagen dealer will replace the fuel tank in your vehicle. This work will take about four hours to complete and will be performed for you free of charge.

**What should you do?** Please contact your authorized Volkswagen dealer without delay to schedule this recall repair.

To help facilitate this repair, please have a quarter tank of fuel or less in your vehicle when you arrive for your scheduled appointment.

**Precautions you should take** If you smell fuel or notice a puddle of fuel beneath your vehicle, please contact your nearest authorized Volkswagen dealer right away.

**Lease vehicles and address changes** If you are the lessor and registered owner of the vehicle identified in this action, the law requires you to forward this letter immediately via first-class mail to the lessee within ten (10) days of receipt. If you have changed your address or sold the vehicle, please fill out the enclosed prepaid Owner Reply card and mail it to us so we can update our records.

**Can we assist you further?** If your authorized Volkswagen dealer fails or is unable to complete this work free of charge within a reasonable time, please contact Customer Relations, Monday through Friday from 8AM to 8PM EST by phone at 1-800-822-8987 or via our "Contact Us" page at [www.vw.ca](http://www.vw.ca).

We apologize for any inconvenience this matter may cause; however we are taking this action to help ensure your safety and continued satisfaction with your vehicle.

Sincerely,

Volkswagen Customer Protection

**NOTE**

Damages resulting from improper repair or failure to follow these work instructions are the dealer's responsibility and are not eligible for reimbursement under this action.

**Required Parts**

<u>Criteria</u>	<u>Quantity</u>	<u>Part Number</u>	<u>Part Description</u>
01	1	3QF201055F	Fuel Tank
	1	N 10628401	Bolt - Trailing arm to bearing housing
	1	WHT005749	Bolt - Trailing arm to bearing housing
	1	N 91268601	Bolt - Trailing arm to bearing housing
	4	N 90936901	Bolt - Seat Frame to Body
	4	N 90994201	Rivet
	1	1J0919133B	Seal Ring
	6	N 91159101	Bolt - Fuel Tank
	2	N 10699801	Bolt - Tank filler neck

**IMPORTANT PARTS INFORMATION**

- The replaced fuel tank will be requested back for analysis.
- Do not destroy the packaging in case it is required when the replaced fuel tank is returned.
- The fuel tank must be completely drained before being returned.

**Required Outside Material**

<p>Locally Sourced Tape Tesa® 4657 (40mm min. width)</p>	
--	--

## Required Tools

 <p>Torque Wrench 5-50Nm -VAG1331- (or equivalent)</p>	 <p>Pry lever -80-200- (or equivalent)</p>
 <p>Fuel Extractor -VAS5190A-</p>	 <p>Trim Removal Wedge -3409- (or equivalent)</p>
 <p>Torque Wrench 1783 2-10Nm -VAG1783- (or equivalent)</p>	 <p>Pop Rivet Pliers -VAG1753B- (or equivalent)</p>
 <p>Wrench - Fuel Sending Unit -T10202-</p>	 <p>Radio Removal Tool -T10057- (3 individual tools are required, 6 are preferred)</p>

## Repair Instruction

### Section A - Check for Previous Repair

#### TIP

If Campaign Completion label is present, no further work is required.

Applicable criteria ID(s)	Campaign/Action Status
01 ← <b>2</b>	Open ← <b>1</b>

**EXAMPLE**

- Enter the VIN in Elsa and proceed to the “Campaign/Action” screen.

#### TIP

On the date of repair, print this screen and keep a copy with the repair order.

- Confirm the Campaign/Action is open <arrow 1>. If the status is closed, no further work is required.
- Note the Applicable Criteria ID <arrow 2> for use in determining the correct work to be done and corresponding parts associated.

**Proceed to Section B**

## Section B – Repair Procedure

### ⚠ WARNING

Risk of injury. Refer to “Warning and Safety Precautions”, found in **Appendix A** at the end of this document.

### ℹ NOTE

- Damages resulting from improper repair or failure to follow these work instructions are the dealer's responsibility and are not eligible for reimbursement under this action.
- This procedure must be read in its entirety prior to performing the repair.
- Due to variations in vehicle equipment and options, the steps/illustrations in this work procedure may not identically match all affected vehicles.
- Diagnosis and repair of pre-existing conditions in the vehicle are not covered under this action.
- When working during extreme temperatures, it is recommended that the vehicle be allowed to acclimate inside the shop to avoid temperature-related component damage/breakage.



- Record the amount of fuel on the fuel gauge.



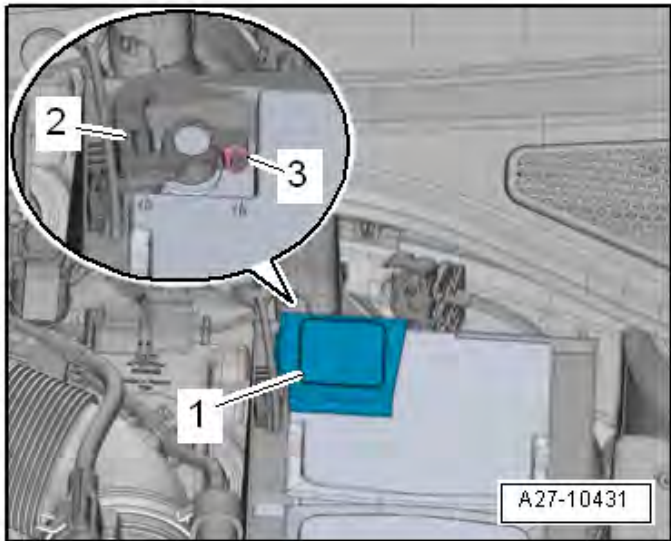

**NOTE**

**Risk for repeat repair!**

Failing to disconnect the battery and failing to fill the fuel tank with the same amount of fuel that was extracted can result in fuel level sending unit faults, or fuel gauge inaccuracies. Additional diagnostic time required to perform a capacitive discharge or remove fused power to the instrument cluster to clear these faults or inaccuracies are NOT covered under this campaign.

- Turn off the ignition and all electrical equipment.
- Move the ignition key outside of the vehicle to prevent the ignition from switching on unintentionally.
- Open the cover <1> over the battery ground terminal post.
- Loosen the nut <3> several turns.
- Remove the battery terminal clamp <2> of the ground cable from the battery terminal.
- Depending on vehicle equipment, disconnect the seat heating connector.
- Remove the bolts <2>.
- Remove the right 2<sup>nd</sup> row seat <1> from the vehicle.

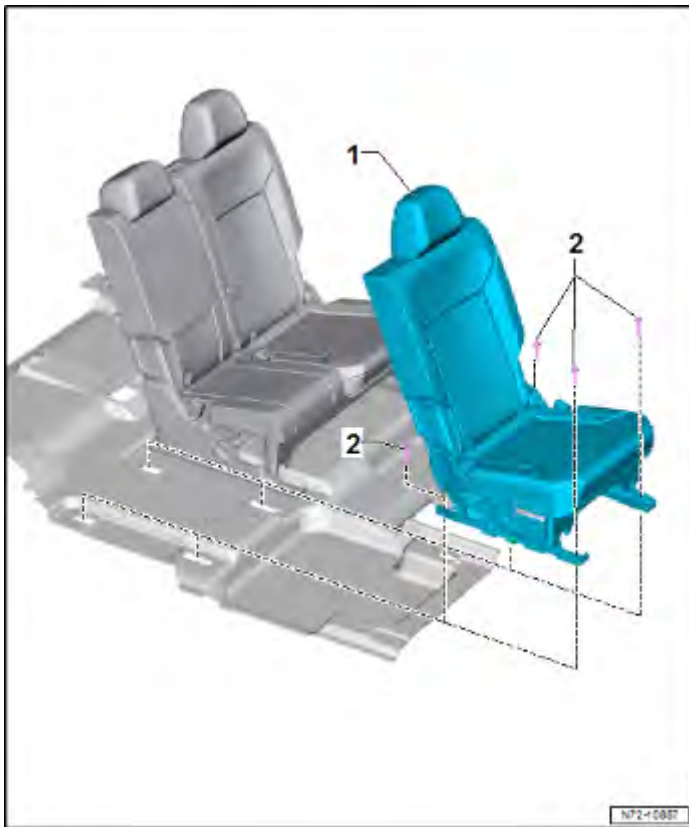

**CAUTION**

If the seat is lifted out of the vehicle or transported, it must not be lifted by the attachments. This includes the seat belt, seat forward/back adjustment lever, seat height adjustment lever and seat trim panels. This is necessary to prevent damage.

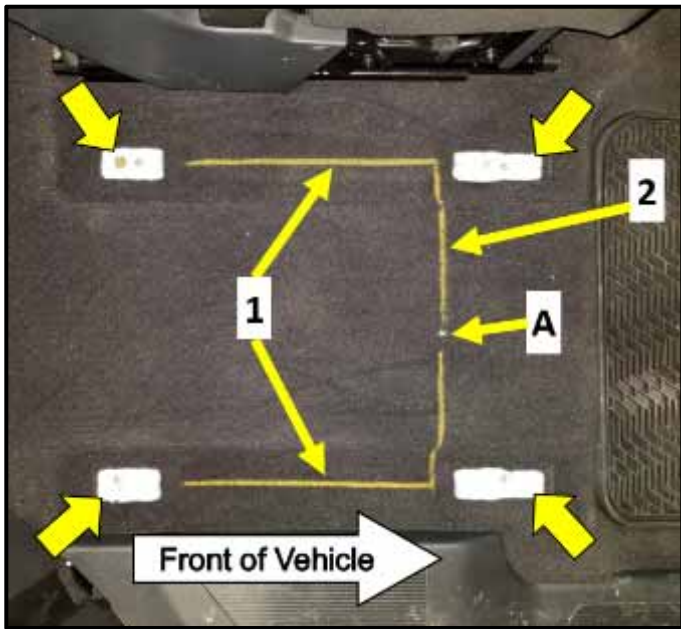

- Cut the carpet under the seat in the highlighted areas <1 and 2>.
- The cutting lines running in the direction of travel <1> will later lie directly under the seat rails.

**⚠ CAUTION**

Do not pull the cutting lines through to the cut-outs for the seat mounts <arrows>.

- When separating, do not damage the wiring harness (if equipped).
- The cutting lines running perpendicular to the direction of travel <2> must be made up to the wiring harness opening <A>.
- Do not cut too deep to avoid damaging the vehicle body.

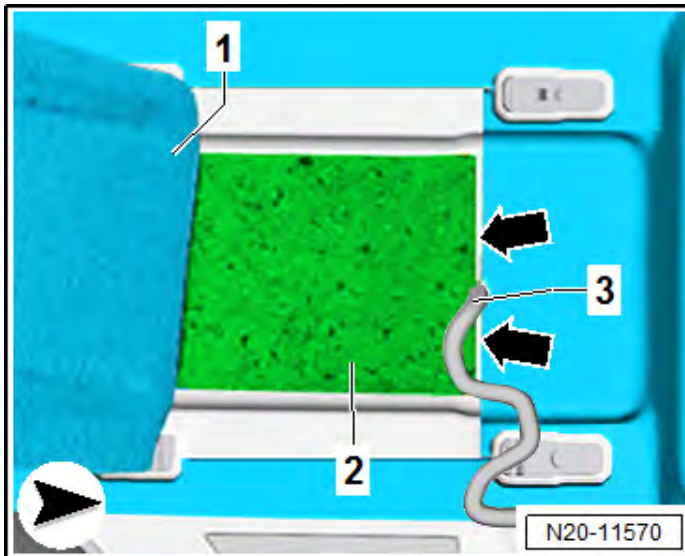

- Guide out the wiring harness <3> (if necessary).
- Fold and support the insulation <2> toward the rear.

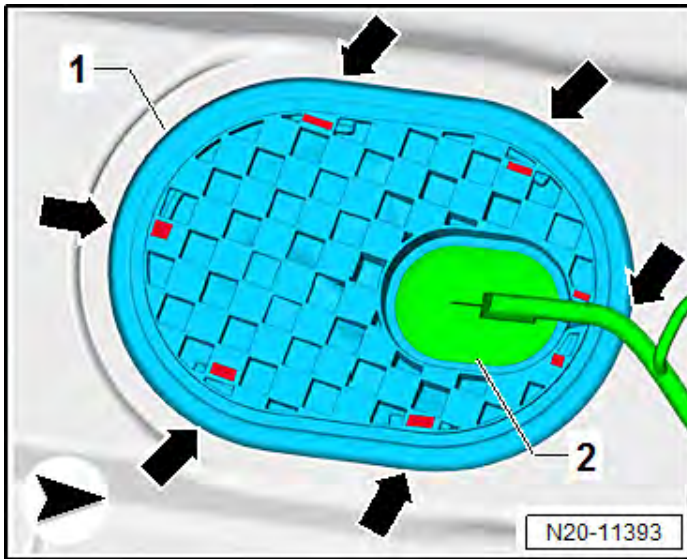

- Unclip the sealing flange cover <1> at the retainers <arrows>.

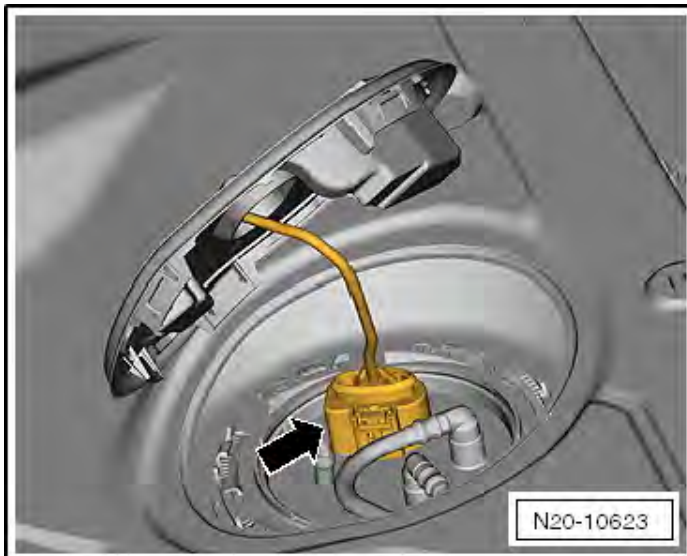

- Release and remove the connector <arrow> from the sealing flange.

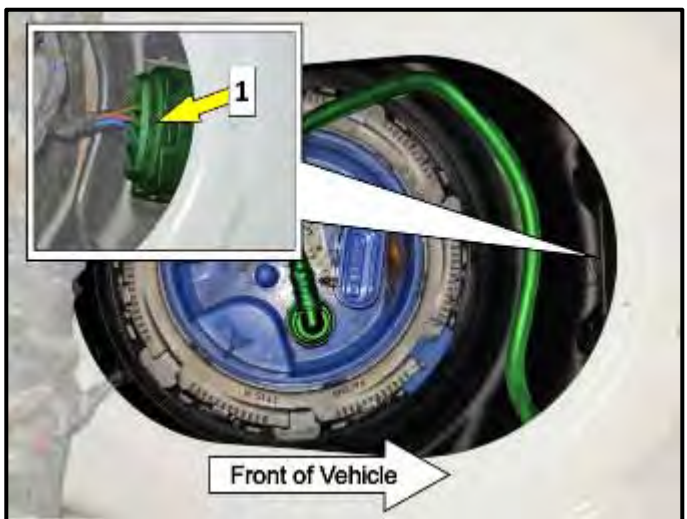

- Disconnect the Fuel Pump Control Module -J538- <1>.

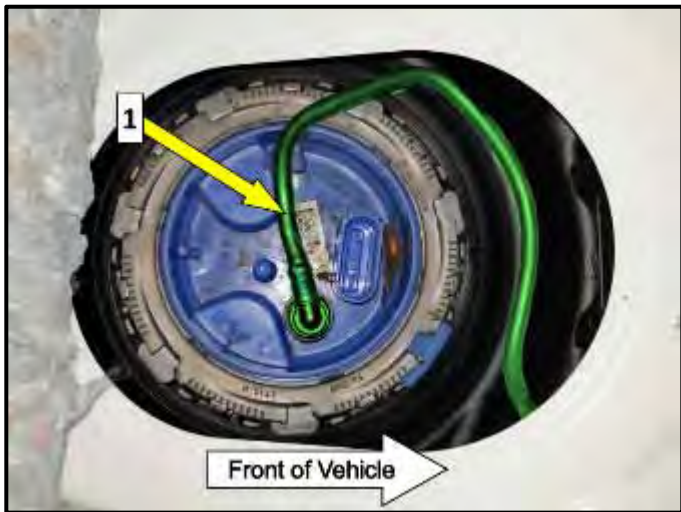

**⚠ CAUTION**

**The fuel system is under pressure.  
Risk of injury from fuel spraying out.**

- Wear protective eyewear.
- Wear safety gloves.
- Reduce the pressure: place clean cloths around the connection point and carefully open the connection point.

- Disconnect fuel line <1>.

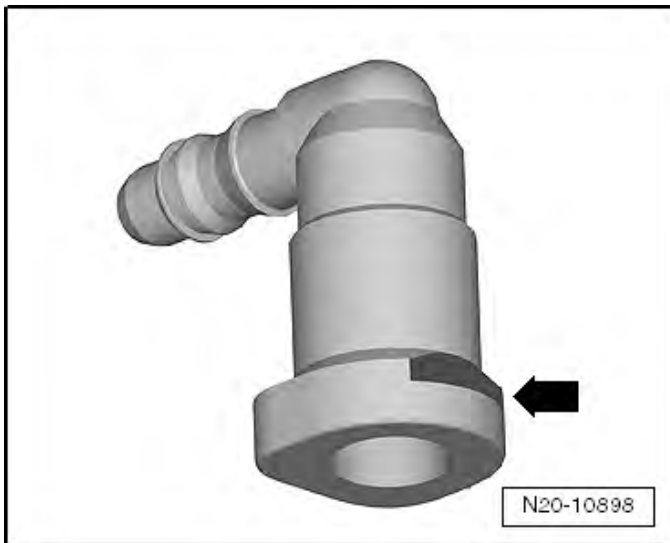

- Press the release button <arrow> and remove the connector coupling from the fuel delivery unit.

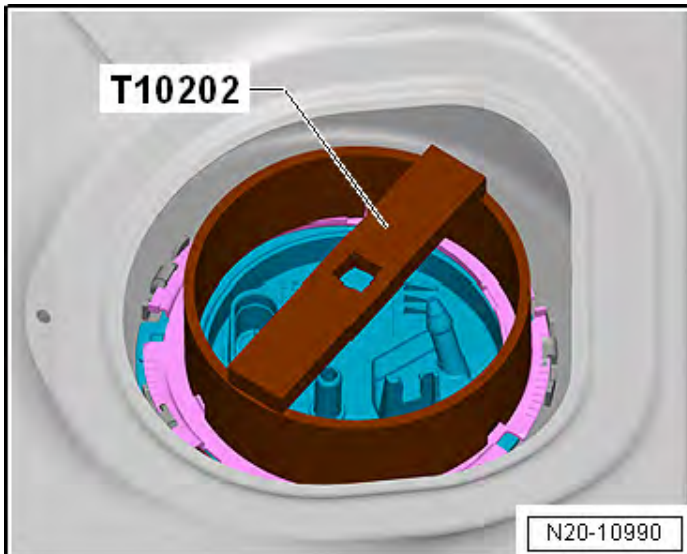

- Open the locking ring using the -T10202-.
- Carefully lift the fuel delivery unit sealing flange.

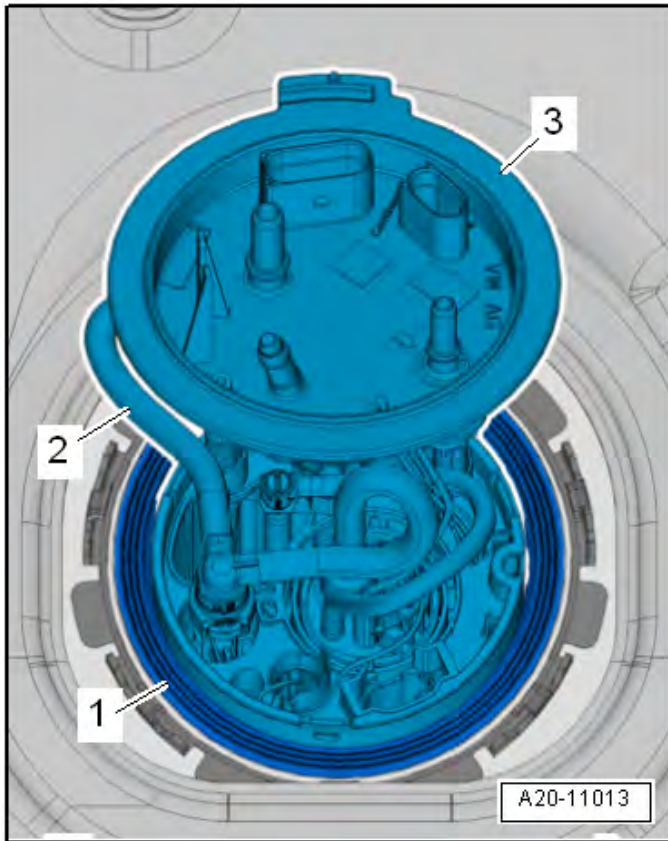

- Cover the area around the fuel pump with absorbent mats to catch any dripping fuel.
- Carefully lift the fuel delivery unit flange <3>, but do not remove the fuel delivery unit.
- Attach the ground wire of the -VAS5190A- to a bare area on the body.
- Insert the suction hose for the -VAS5190A- as deep as possible into the fuel tank.
- Extract the fuel using the -VAS5190A-.
- Record the amount of fuel extracted.

**NOTE**

The fuel delivery unit will need to be transferred to the new fuel tank after the tank is removed from the vehicle.

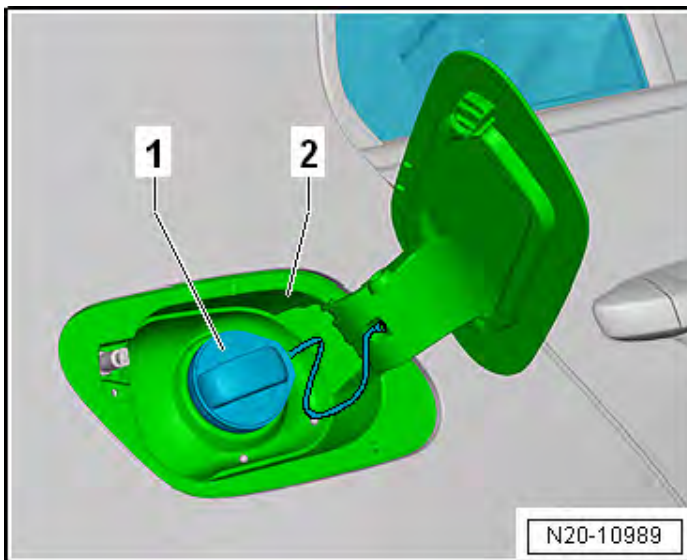

- Open the fuel filler door unit <2>.
- Clean the area around the fuel filler neck.
- Remove the cap <1> for the fuel filler neck.

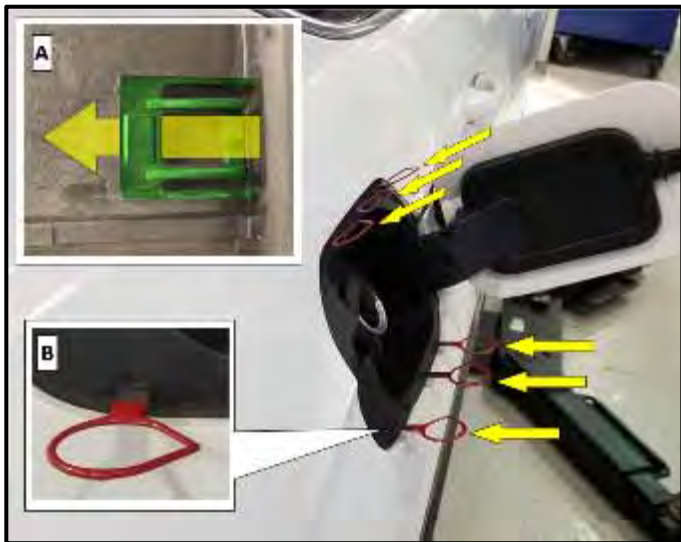

**NOTE**

Using six Radio Removal Tools -T10057- is the preferred method of removing the fuel filler door unit. However, it is possible to remove the fuel filler door unit using only three. When using only three, release the bottom locking tabs first and then release the top.

- Remove the fuel filler door unit.
  - Remove the rubber seal around the filler neck.
  - Push six Radio Removal Tools -T10057- through the recesses on the fuel filler door unit as shown in inset <B>.
  - The tools need to release the locking tabs as shown in inset <A>.
  - Reach through the fuel filler neck seal opening and pull the fuel filler door unit away from the body.
  - Rotate the fuel filler door unit out of the body.
  - Guide out the drain tube.
  - Disconnect fuel tank filler door motor connector.
  
- Correct Radio Removal Tool -T10057- <A> placement under retainer <1>.

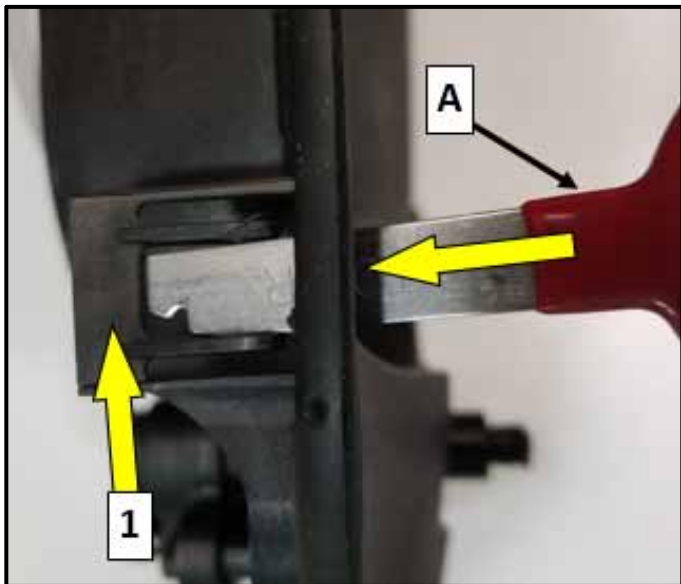

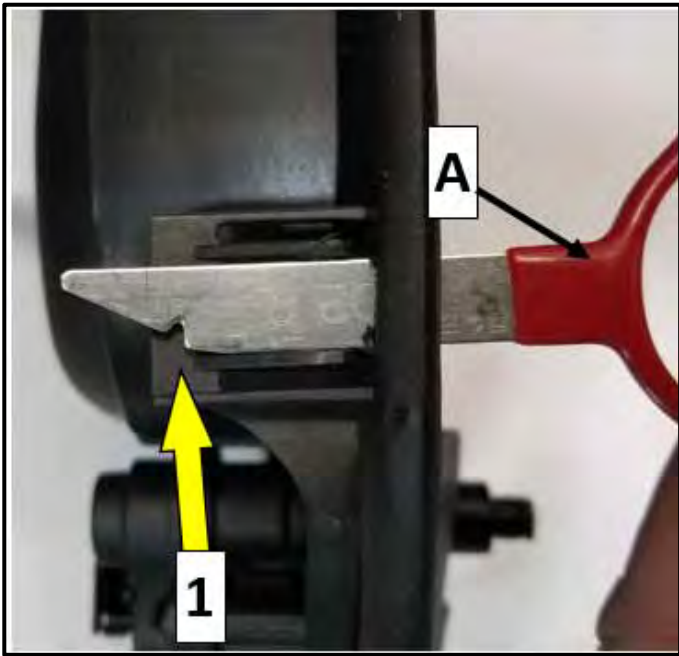

- If the Radio Removal Tool -T10057- <A> is inserted over retainer <1>, the locking tabs will not fully release.

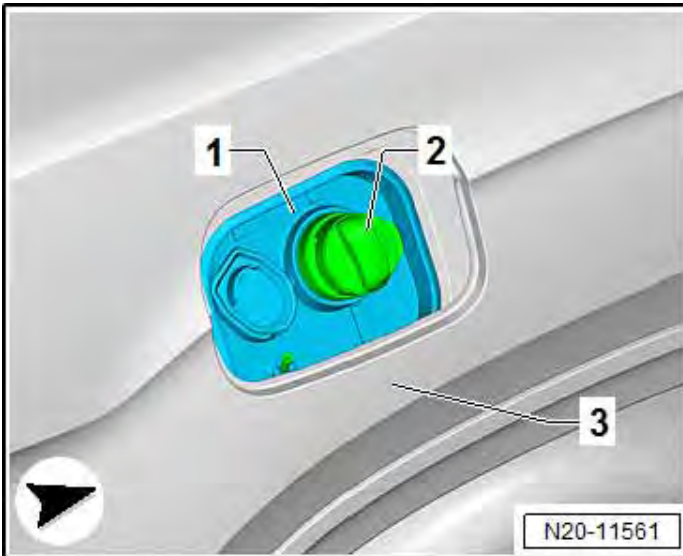

- Pull out and remove the sealing cover <1> from the body <3>.
- Guide out the sealing cover <1> over the filler tube <2>.

**NOTE**

- The sealing cover <1> may have additional tape applied.
- When removing the cover, try to keep the tape intact for reinstallation.
- If the tape is compromised, apply new tape during installation.
  - Recommended tape: Tesa® 4657.

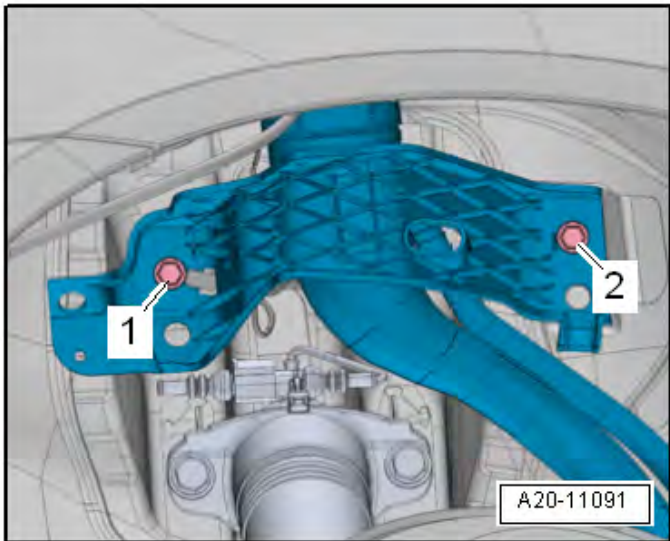

- Remove the fuel filler neck bolts <1 and 2>.

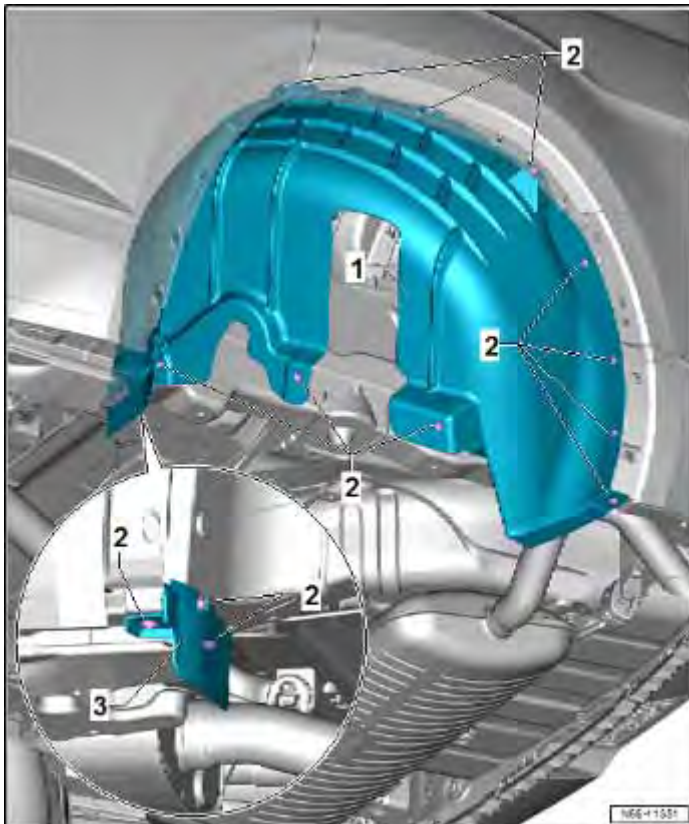

- Remove the right rear wheel.
- Remove the bolts <2>.
- Remove the rear wheel housing liner <1> out of the wheel housing on the sill panel cover <3>.



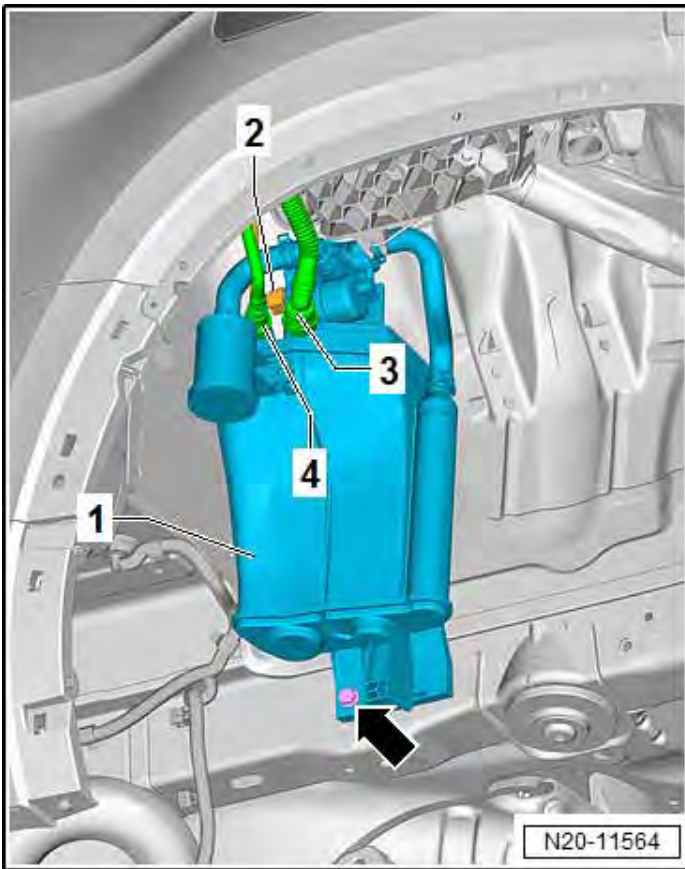

- Release and remove the breather lines <3 and 4> from the charcoal canister <1>.

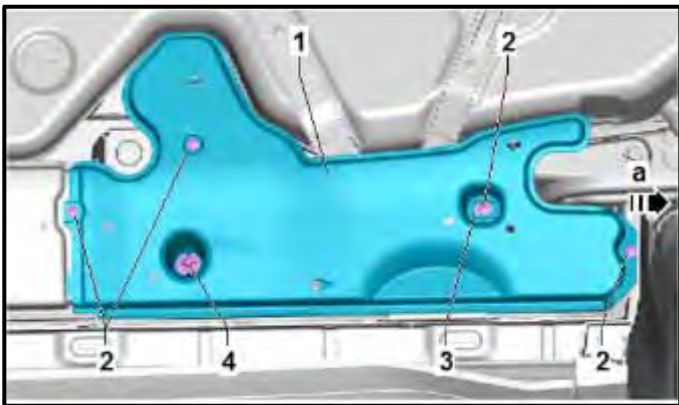

- Remove the nuts <4> and bolts <2> and remove the right rear underbody trim panel <1> toward the rear <arrow a>.

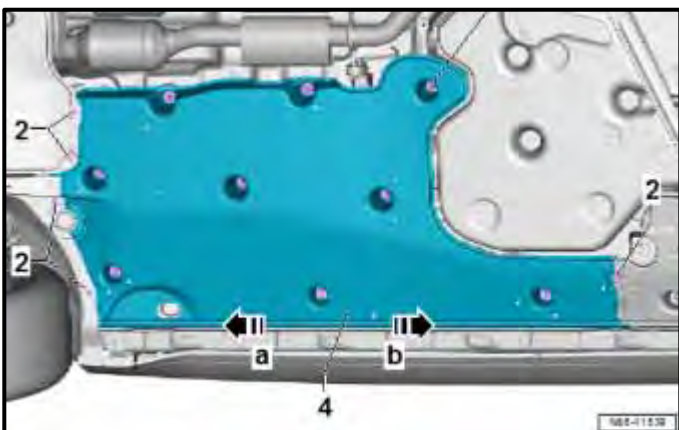

- Remove bolts <2>.
- Loosen underbody trim nuts.
- Pull the underbody trim panel <4> toward the rear in direction of <arrow b> out of the noise insulation.

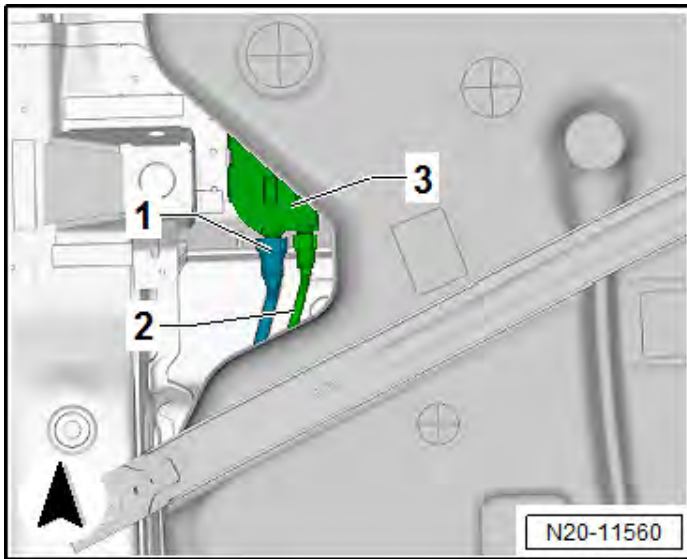

**CAUTION**

**The fuel system is under pressure.  
Risk of injury from fuel spraying out.**

- Wear protective eyewear.
- Wear safety gloves.
- Reduce the pressure: place clean cloths around the connection point and carefully open the connection point.
- Disconnect the fuel line <2> and the breather line <1>.
- Press the release button <arrow> and remove the connector couplings from the fuel lines.

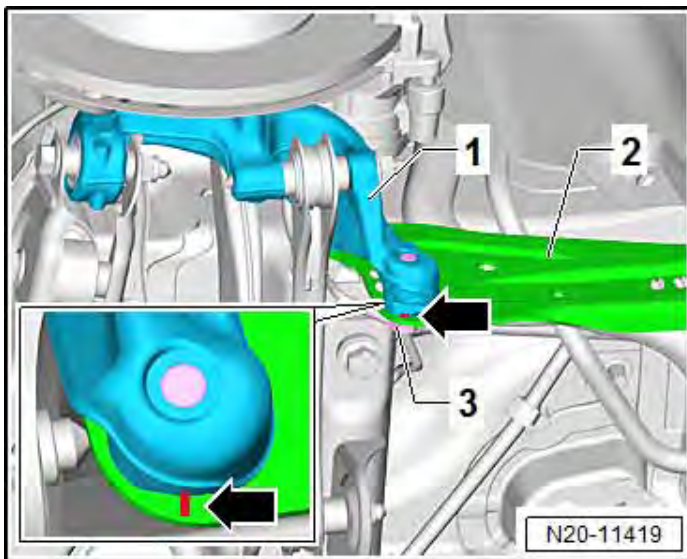
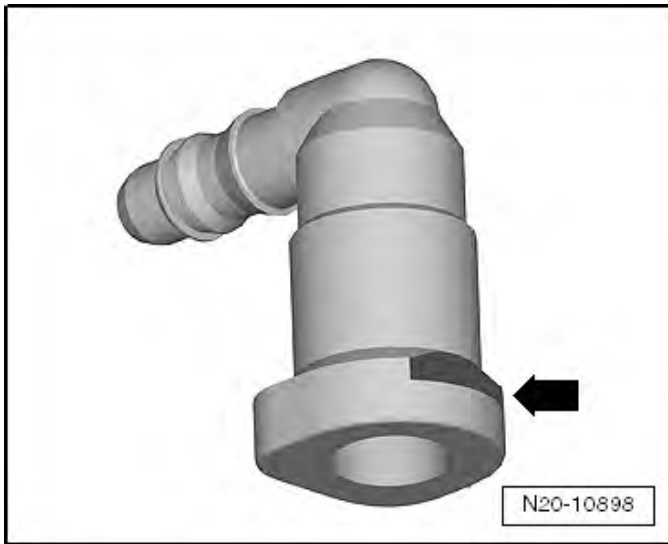

- Mark the installation position between the wheel bearing housing <1> and the trailing arm <2>.
- Use a suitable pen for this.
- Apply the mark in the area shown <arrow> on the trailing arm and the wheel bearing housing.

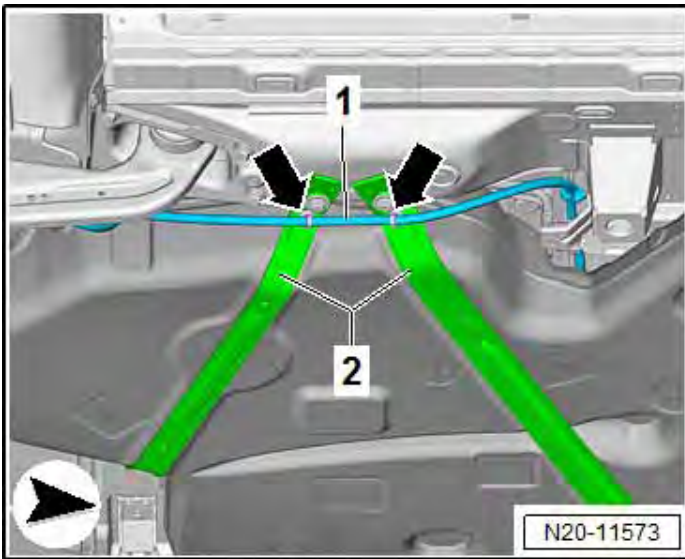

- Unclip the wiring harness <1> on the mounting straps <2> <arrows>.

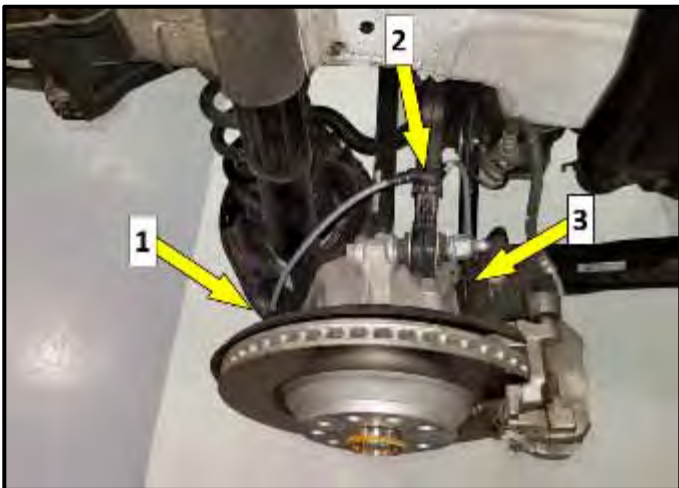

- Disconnect connectors for ABS sensor <1> and parking brake motor <3>.
- Remove wiring harness from upper control arm <2>.



- Support the wheel bearing housing with a screw jack.

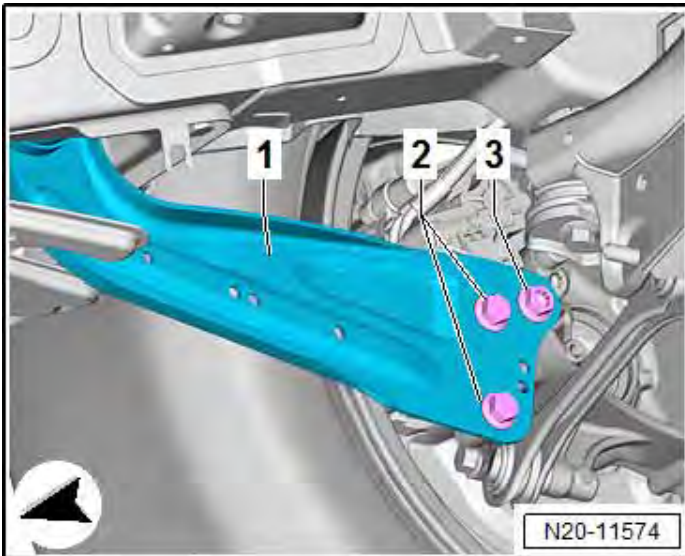

- Remove the bolts <2 and 3> and pivot the trailing arm <1> downward.

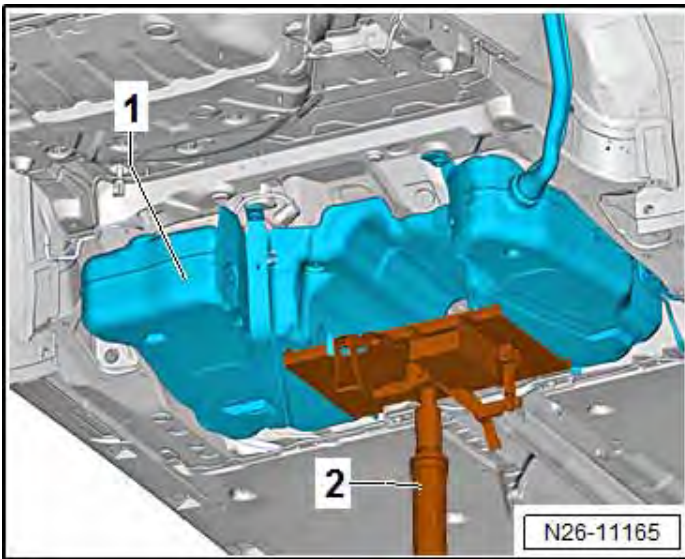

- Place the -VAS6931- <2> under the fuel tank <1> to support it as shown.

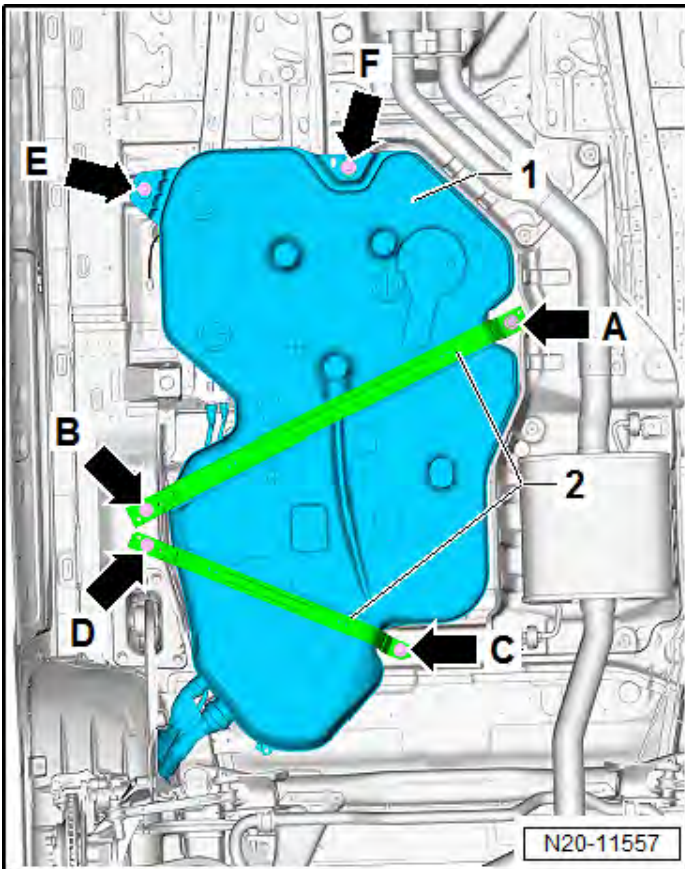

- Remove the bolts <arrows>.
- Lower the fuel tank with straps <2> still installed using the -VAS6931-.
- By turning it accordingly, lower the fuel tank sideways.
- Guide the filler neck out between the rear axle and the body.
- A second mechanic is required to guide out the fuel filler tube by hand at the trailing arm.

#### IMPORTANT PARTS INFORMATION

- The replaced fuel tank will be requested back for analysis.
- Do not destroy the packaging in case it is required when the replaced fuel tank is returned.
- The fuel tank must be completely drained before being returned.

- Carefully remove the fuel delivery unit with both lines <3 and 4> as much as possible out of the fuel tank opening.
- At the same time turn and tilt the corresponding fuel delivery unit.

**⚠ CAUTION**

Be careful not to bend the floater arm on the fuel level sensor when removing the fuel delivery unit.

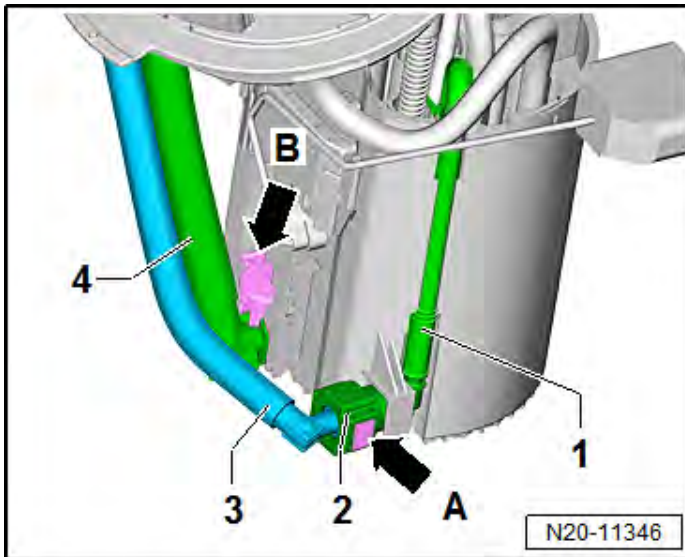

- Place a cloth underneath to catch the leaking fuel, since the fuel delivery unit is still filled.
- Push the release buttons <arrow A> on the connecting piece <2>.
- Remove the line <3> from the line <1>.
- Pull the locking mechanism <arrow B> upward.
- To do this, push the locking mechanism and pull the slider upward.
- Remove the line <4>.
- Transfer the fuel delivery unit to the new fuel tank.
- Be careful not to bend the floater arm on the fuel level sensor when inserting the fuel delivery unit.
- At the same time turn and tilt the corresponding fuel delivery unit.
- Attach the fuel lines <4> until it clicks into place.
- Slide the fuel lines <3> onto the connection.
- Push the slider <B> downward.
- Check if both fuel lines are secure by pulling on them.

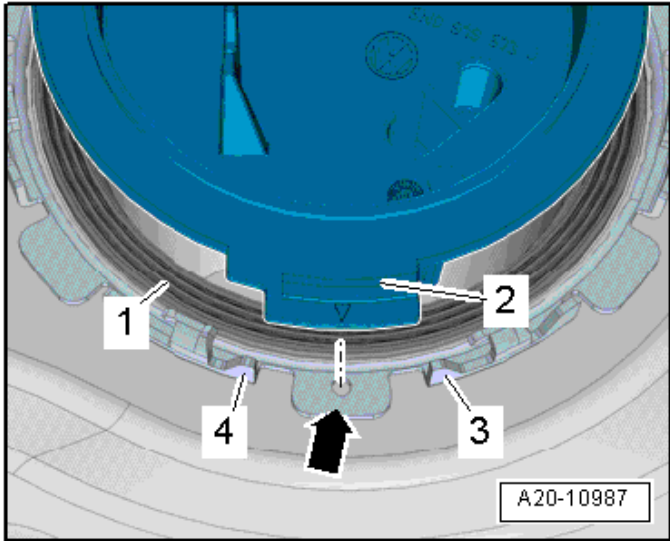

- Install the dry fuel delivery unit seal <1> into the opening in the fuel tank.

Part Number	Part Description
1J0919133B	Seal Ring

- Push the sealing flange <2> down against the spring force.
- The tab <2> on sealing flange must lie between tabs <3 and 4> on the fuel tank.
- The arrow on the fuel tank must point to the tab <2>.

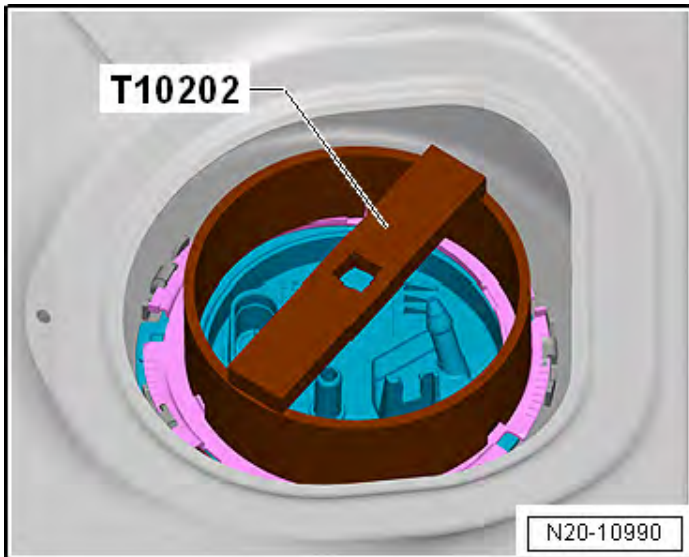

- With the aid of a second technician install the locking ring using the -T10202- and torque to 110 Nm.

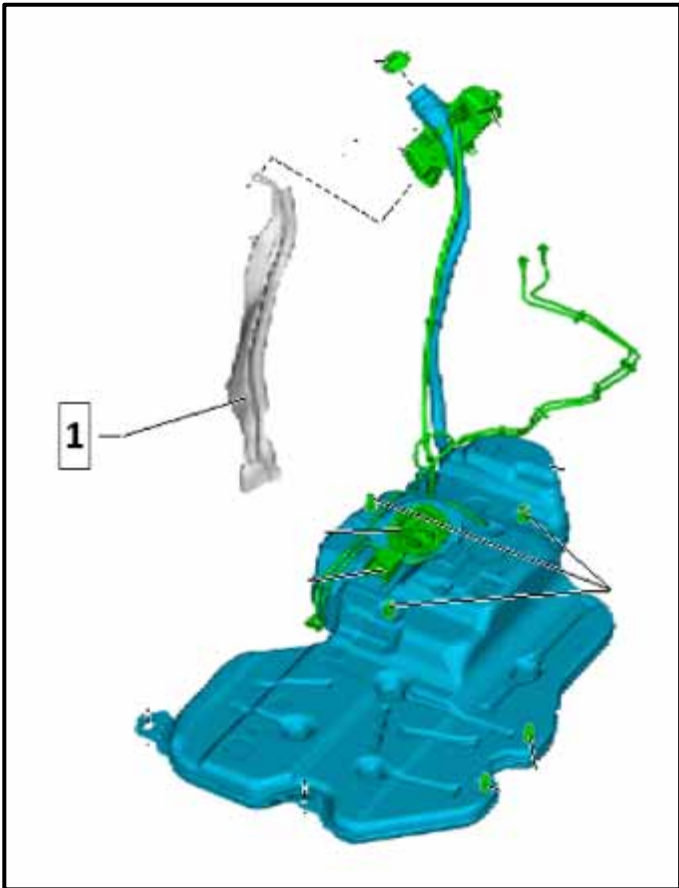

- Drill out filler neck shield rivets from the old fuel tank.
- Transfer shield onto new fuel tank.

Qty.	Part Number	Part Description
4	N 90994201	Rivet

**NOTE**

The holes in the tabs on the new fuel tank may need to be enlarged slightly in order to accept the new rivets. Use a 5 mm max drill bit to expand the holes.

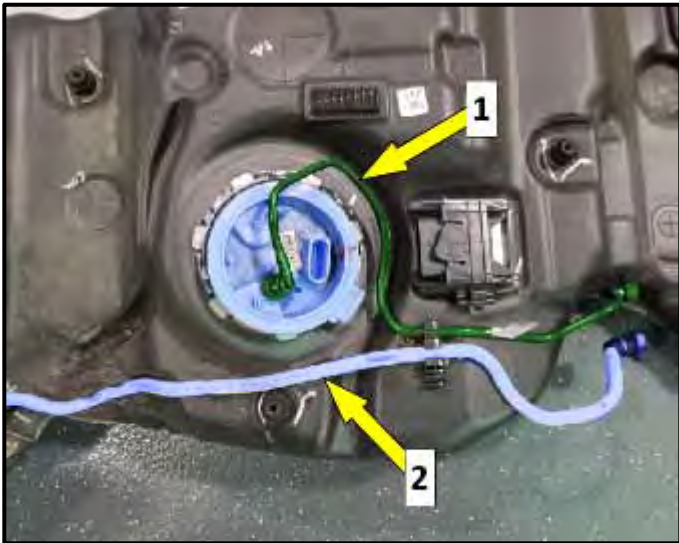

- Transfer fuel line <1> and vent line <2> to the new fuel tank.

**CAUTION**

- The connector couplings must audibly engage when locking.
- Pull on the connector coupling to make sure it is secure.





- Note the installation position of the fuel line and vent line.

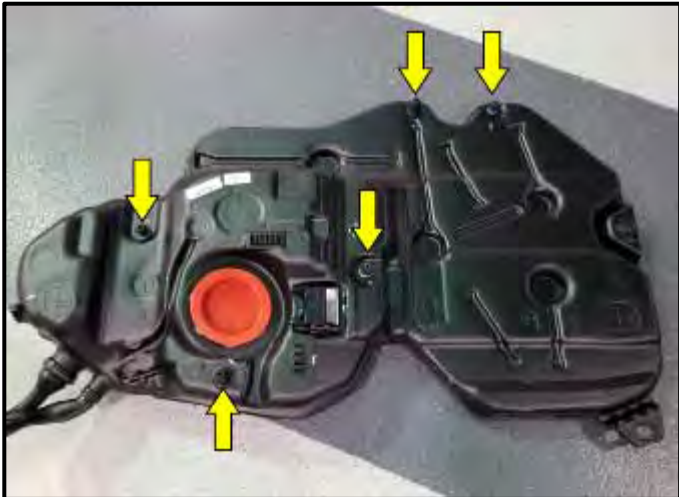

- Ensure the rubber bumpers <arrows> are fully seated onto the new fuel tank.

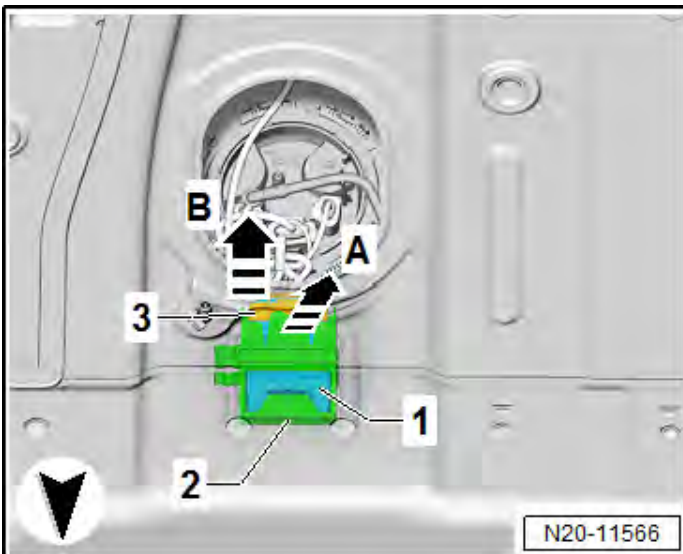

- Transfer the Fuel Pump Control Module -J538-:
  - Carefully pull the Fuel Pump Control Module -J538- <1> out of the mount <2>.
  - Install the Fuel Pump Control Module -J538- onto the new fuel tank.

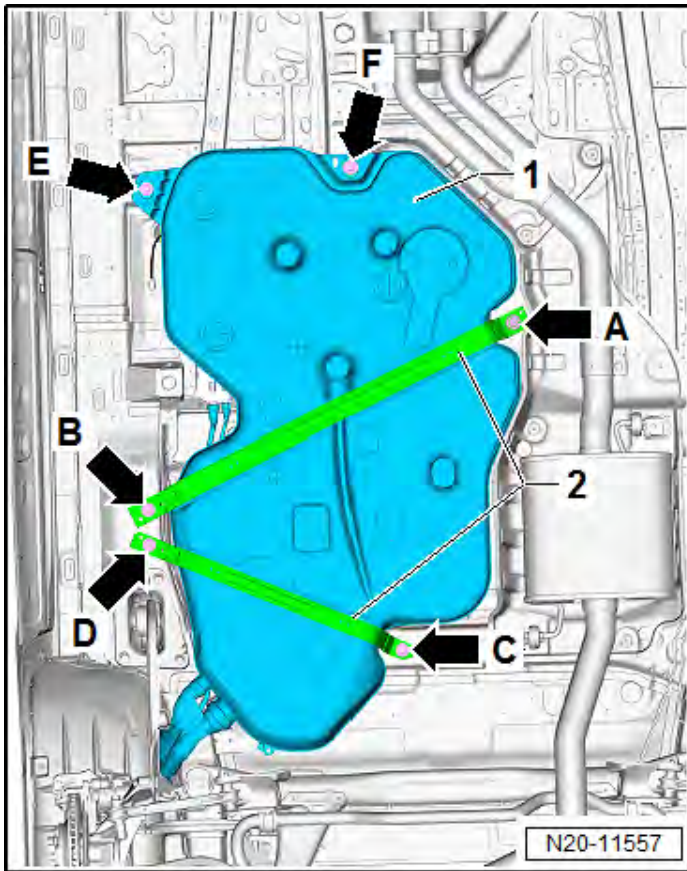

- Transfer the mounting straps <2> to the new fuel tank.
- Position the fuel tank together with the mounting straps on the underbody using the -VAS6931-.
- Guide the filler neck between the rear axle and the body.
- Make sure to guide the fuel filler neck correctly into the opening in the body.
- Install and torque bolts <arrows> to 20 Nm + 90°.

Qty.	Part Number	Part Description
6	N 91159101	Bolt – Fuel Tank

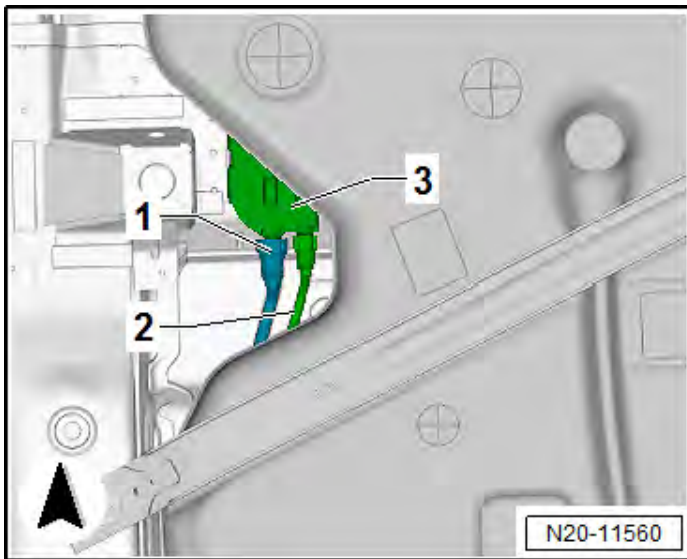

- Connect the fuel line <2> and the breather line <1> on the underbody.

### **CAUTION**

- The fuel lines attached to the body must be held in place when connecting the fuel lines.
- The connector couplings must audibly engage when locking.
- Pull on the connector coupling to make sure it is secure.



- Support the wheel bearing housing with a screw jack so the trailing arm to wheel bearing housing bolt holes align.

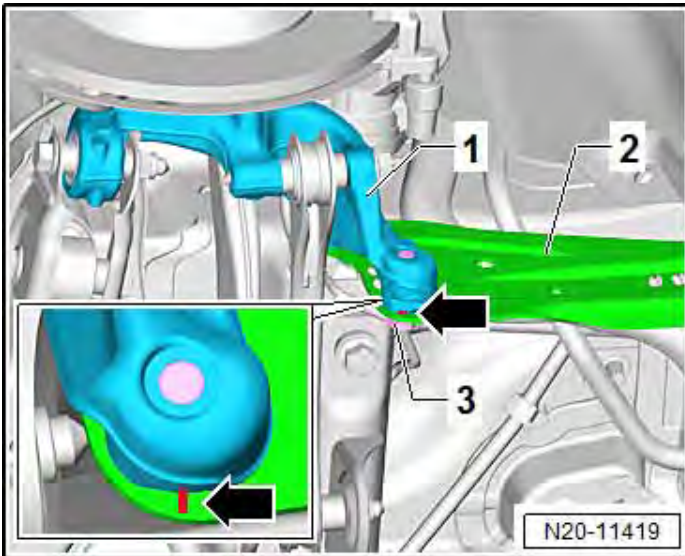

- Align the wheel bearing housing <1> and the trailing arm <2> to each other.
- Use the previously applied marking to do this <arrow>.

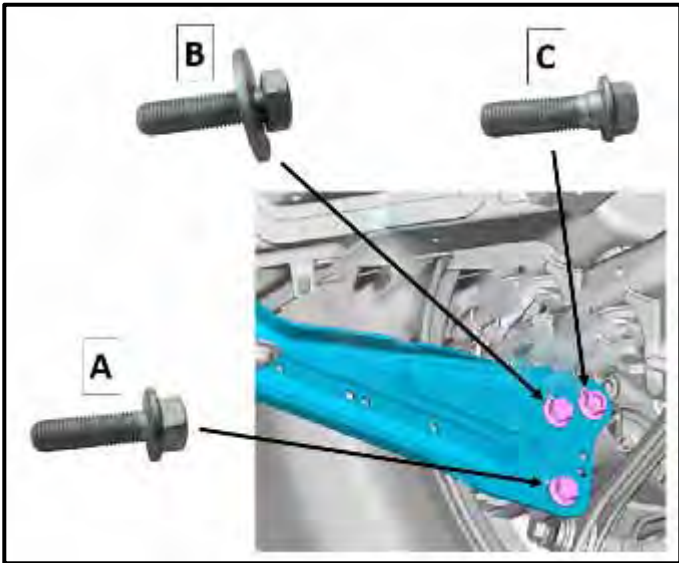

- Install the following bolts in their respective locations and torque to 70 Nm + 90°.

Part Number	Location
N 10628401	A
N 91268601	B
WHT005749	C

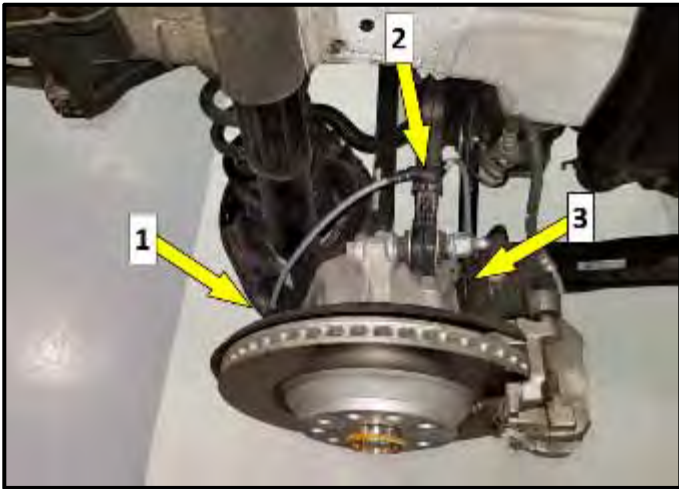

- Reconnect connectors for ABS sensor <1> and parking brake motor <3>.
- Install wiring harness <2> onto upper control arm.

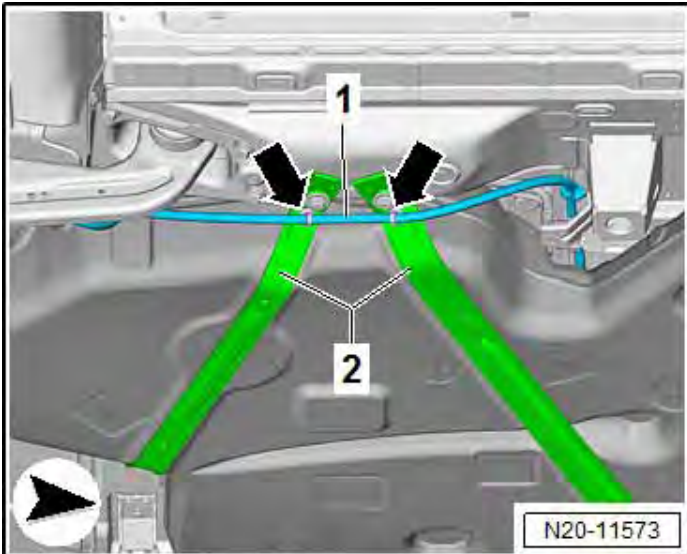

- Clip the wiring harness <1> on the mounting straps <2> <arrows>.

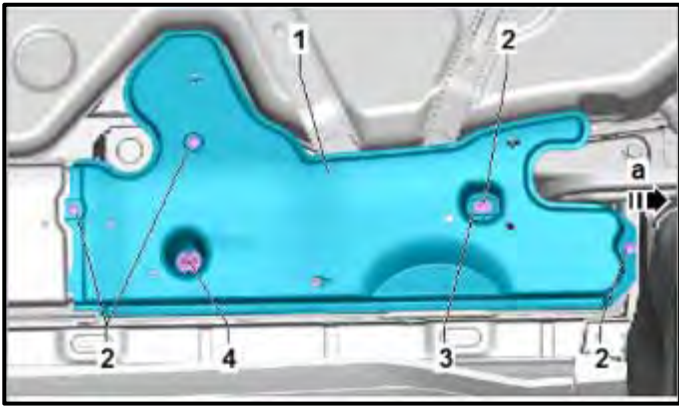

- Install the front and rear underbody trim panels and torque fasteners to 2.0 Nm.

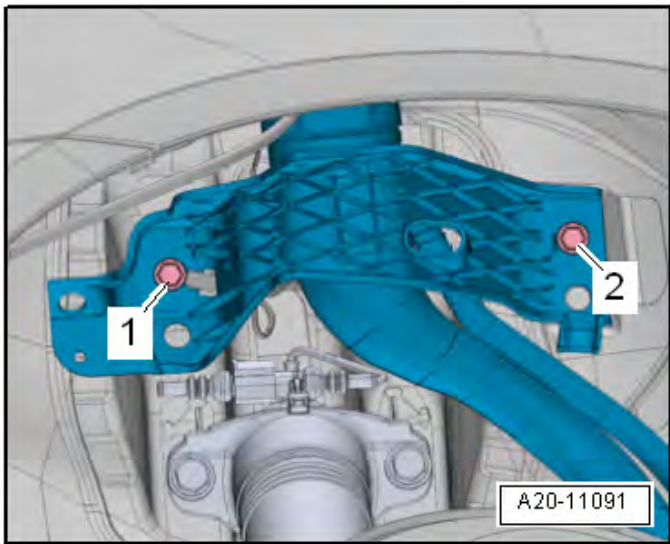

- Install new fuel filler neck bolts <1 and 2> and torque to 8 Nm + 90°.

Part Number	Part Description
N 10699801	Bolt – Tank Filler Neck

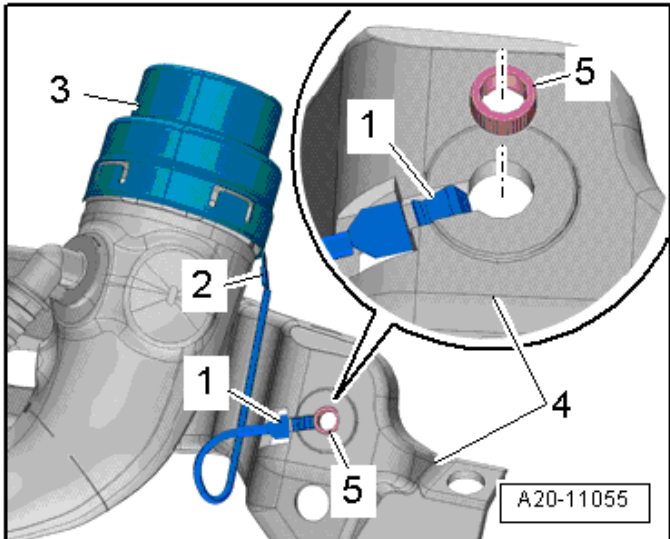

- Check the ground cable for traces of oxidation on the connectors. Remove any oxidation if necessary.
- Check the installation position of the ground connection.
- The connector <2> must be securely attached to the metal ring <3>.
- The contact <1> must be engaged in the fuel tank <4> and secured with the spacer <5>.
- Check the metal ring connection on the fuel filler neck to a bare area on the body with an ohmmeter.
- Specified value is approximately 0 ohm.

**⚠ WARNING**

If the specified values is incorrect, then there is a risk of explosion due to electrostatic discharge.

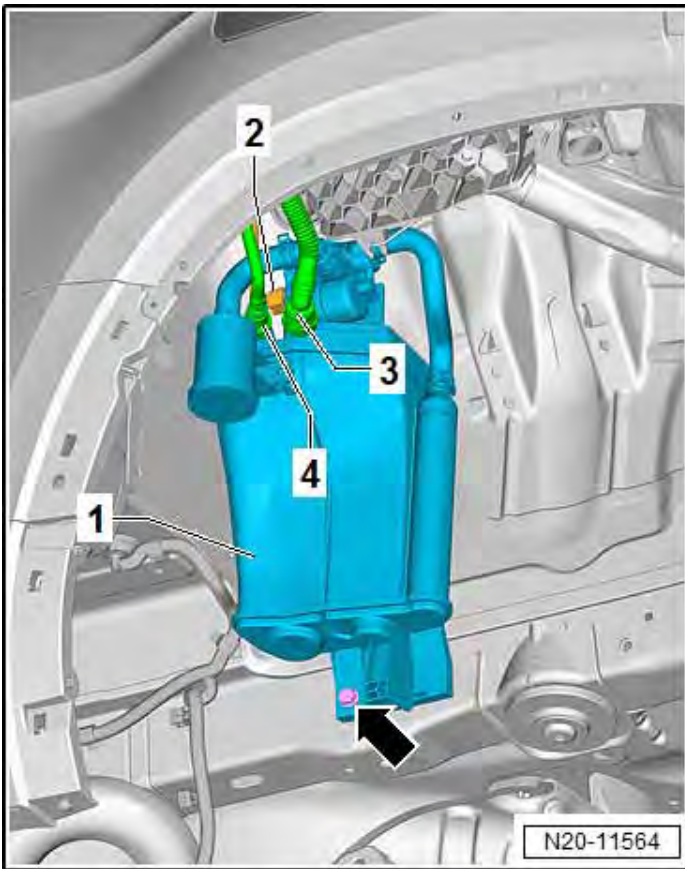

- Install breather lines <3 and 4> to the charcoal canister <1>.

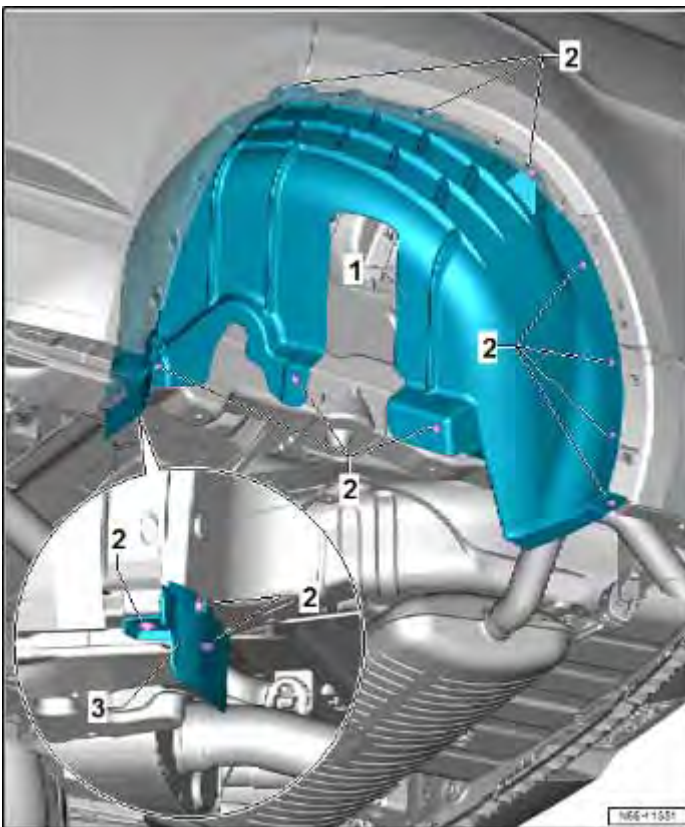

- Install the right wheelhouse liner <1> and torque bolts <2> to 2.0 Nm.
- Install the wheel and torque lug bolts to 120 Nm.

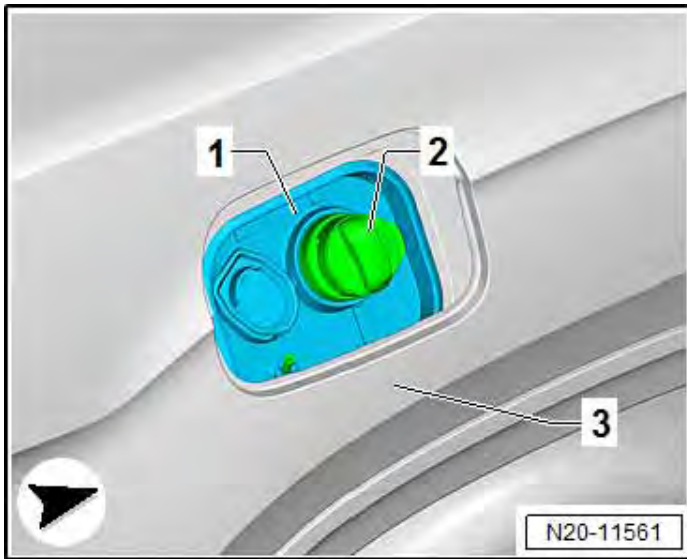

- Install the sealing cover <1> into the body <3>.

**NOTE**

- The sealing cover <1> may have had additional tape applied.
- If the tape was compromised, apply new tape.
  - Recommended tape: Tesa® 4657.

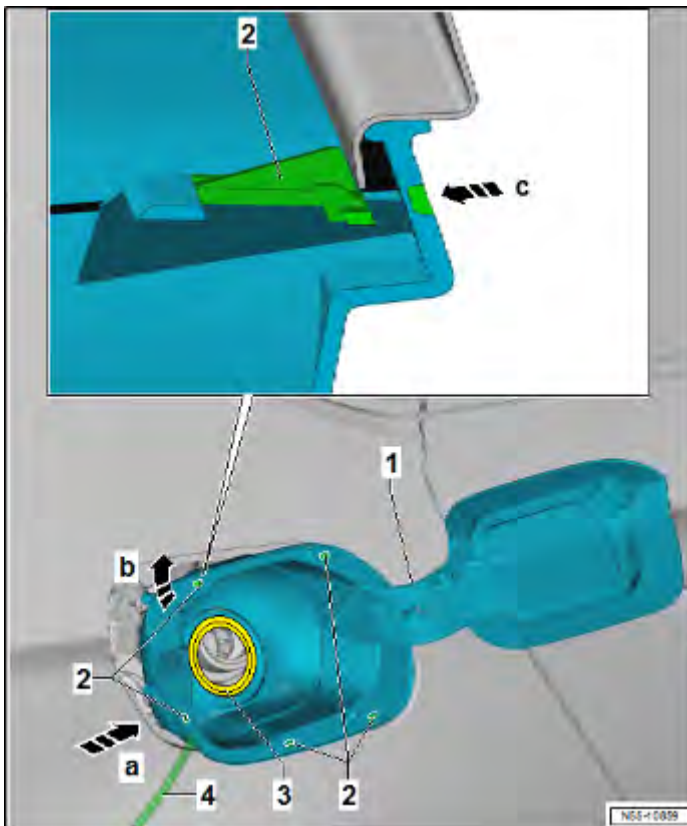

- Install the fuel filler door unit:
  - Connect the fuel filler door lock connector.
  - Insert the water drain hose <4> through the opening in the fuel filler door unit <1> and then pull it all the way through.
  - Push the water drain hose <4> into the side panel.
  - Push the fuel filler door unit <1> in the side panel in direction of <arrow a> and pivot inward in direction of <arrow b>.
  - Push the fuel filler door unit <1> on the side panel in direction of <arrow c> until the hooks <2> engage.
  - Pull the boot over the filler neck <3>.

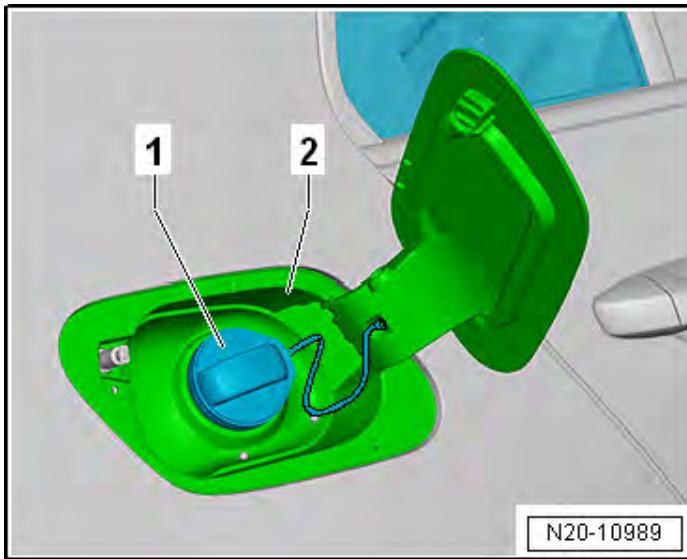

- Install the fuel cap <1>.
- Close the fuel filler door.

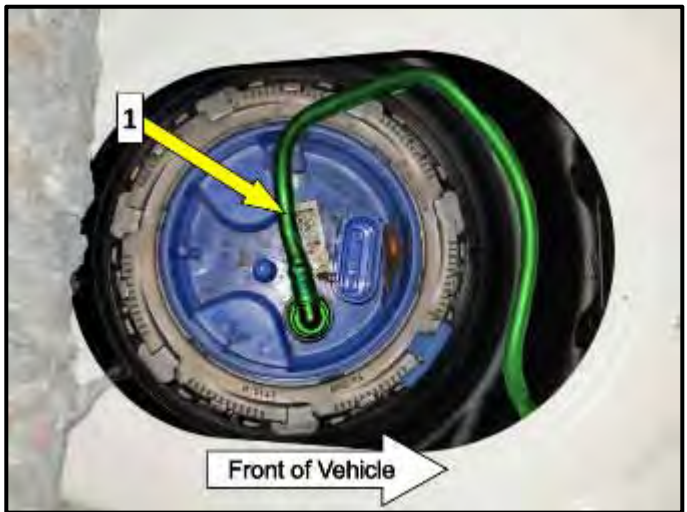

- Verify the fuel line <1> is connected.

<b>⚠ CAUTION</b>
<ul style="list-style-type: none"> <li>• The connector couplings must audibly engage when locking.</li> <li>• Pull on the connector coupling to make sure it is secure.</li> </ul>

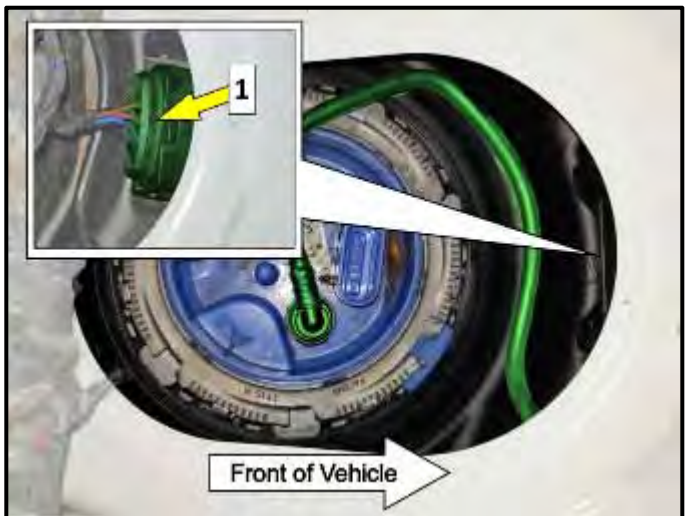

- Connect Fuel Pump Control Module -J538- <1>.



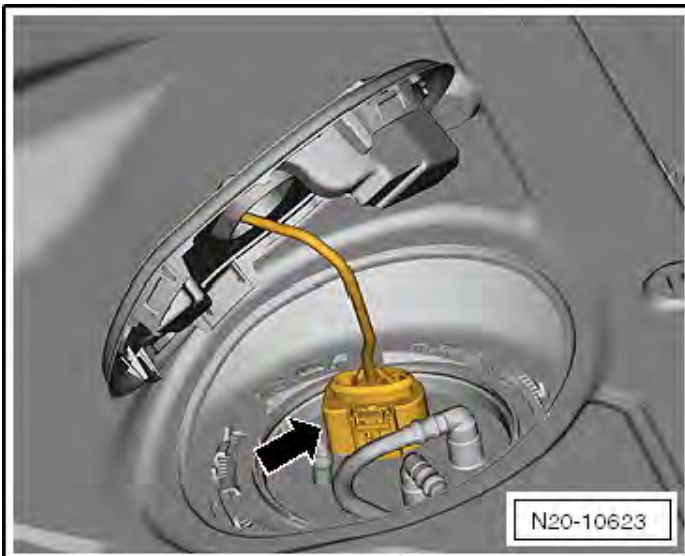

- Connect the connector <arrow> to the sealing flange.

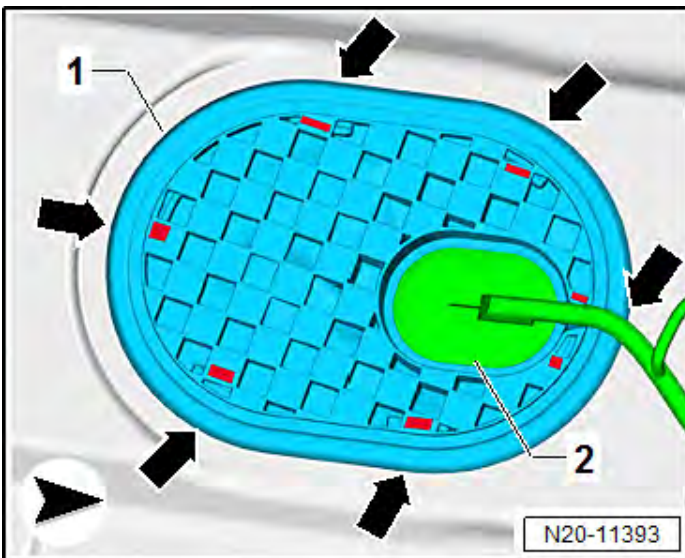

- Install the sealing flange cover <1>.

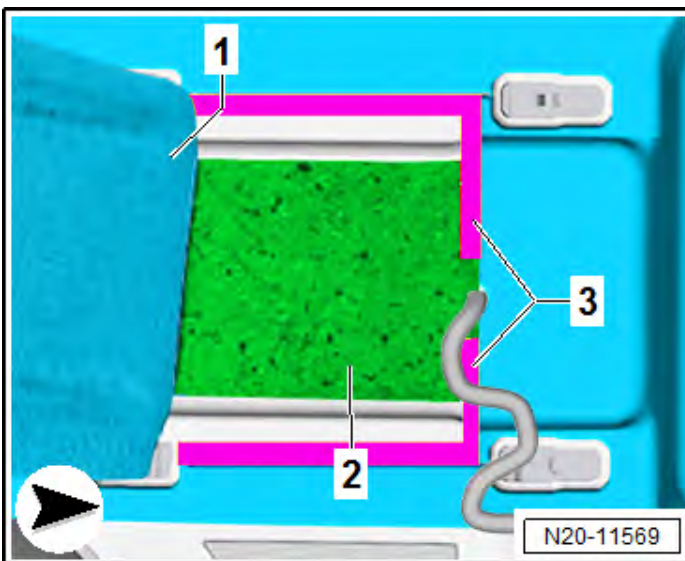

- Fold the insulation <2> under.
- Apply tape (Tesa® 4657) <3> as shown under the carpet. The adhesive surface faces upward for this.
- The width of the cloth tape must be at least 40 mm.
- Half of the total width of the cloth tape is taped to the bottom of the carpet.
- Use the other half of the total width to tape the folded up section of the carpet.
- Fold the carpet <1> down.
- Tape the carpet without any creases or bumps.
- Check that the carpet is positioned securely.

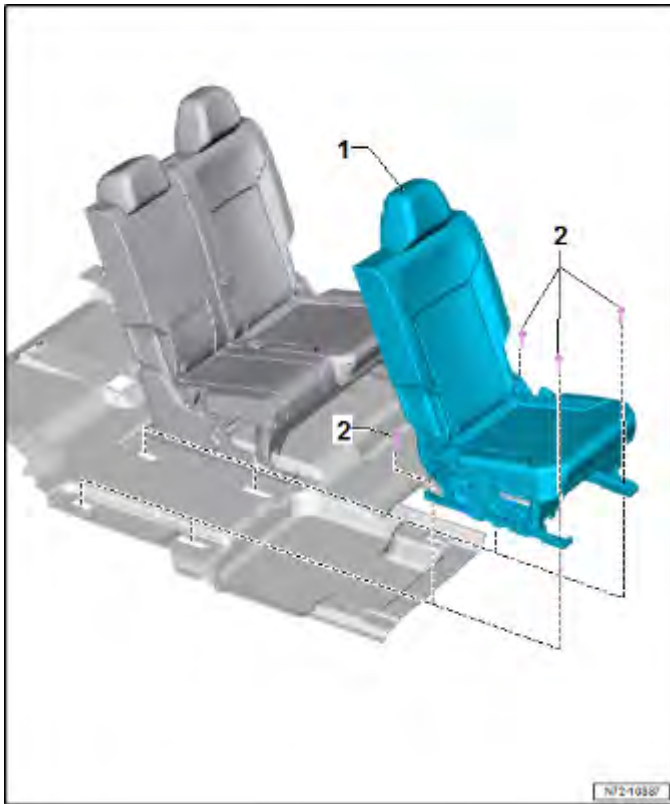

**⚠ CAUTION**

If the seat is lifted out of the vehicle or transported, it must not be lifted by the attachments. This includes the seat belt, seat forward/back adjustment lever, seat height adjustment lever and seat trim panels. This is necessary to prevent damage.

- Install right 2<sup>nd</sup> row seat <1>.
- Install bolts <2> and torque to 40 Nm.

Qty.	Part Number	Part Description
4	N 90936901	Bolt – Seat Frame to Body



- Refer to the amount of fuel that was previously removed and add this amount of fuel back into the vehicle.

**⚠ WARNING**

**Risk of the fuel tank exploding when starting the fuel pump.**

- Severe injuries and burns are possible.
- After installing a new or completely empty fuel tank, fill with at least 5 liters (1.3 gallons) of fuel before attempting to start the engine.

**! NOTE**

**Risk for repeat repair!**

Failing to disconnect the battery and failing to fill the fuel tank with the same amount of fuel that was extracted can result in fuel level sending unit faults, or fuel gauge inaccuracies. Additional diagnostic time required to perform a capacitive discharge or remove fused power to the instrument cluster to clear these faults or inaccuracies are NOT covered under this campaign.

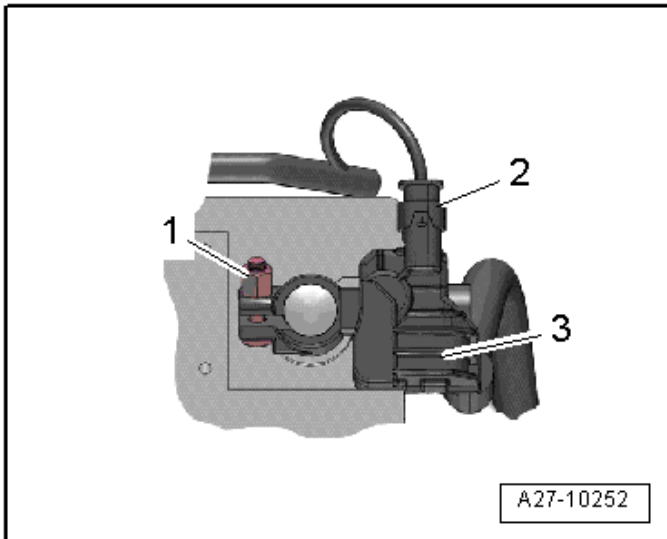

- Reconnect the battery.
  - Disconnect the connector <2> from the Battery Monitoring Control Module -J367- <3>.
  - Install the battery ground cable terminal clamp by hand on the battery negative terminal “-”.
  - Tighten the nut <1> to 6 Nm.
  - Reconnect the connector <2> to the Battery Monitoring Control Module -J367-.



- Switch the ignition ON.
- Attach an appropriate VAS tester to the vehicle.
- Clear all DTCs.
- Cycle the ignition multiple times and check for fuel leaks.
- Reset customer convenience basic settings (i.e. one touch windows, instrument cluster clock, etc.).

**Proceed to section C.**

## Section C – Campaign Completion Label

### Install Campaign Completion Label

- Fill out and affix Campaign Completion Label, part number CAMP 010 000, next to the vehicle emission control information label.



#### TIP

Ensure Campaign Completion Label does not cover any existing label(s).

**Proceed to Section D.**

## Section D - Parts Return

Properly store (retain) removed parts in accordance with all state/province and local requirements, unless otherwise indicated and/or requested through the Warranty Parts Portal (WPP) for U.S. and the Part Destruction and Core Disposition Report for Canada.

## Appendix A – Warning and Safety Precautions

### WARNING

- There is a risk of injury due to the fuel being under pressure.
- The fuel system is under pressure. Injuries are possible from fuel spraying out.
- Before opening the fuel system:
  - Wear protective eyewear.
  - Wear safety gloves.
  - Reduce the pressure: place clean cloths around the connection point and carefully open the connection point.
- Risk of a fire due to leaking fuel.
- When the battery is connected, the door contact switch activates the fuel pump when opening the driver door. Leaking fuel can ignite and start a fire.
- Before opening the fuel system, interrupt the power supply to the fuel pump.
- Do not let fuel come in contact with skin. Wear fuel-resistant gloves.
- Danger of explosion due to cell phones. Keep cell phones out of reach in the work space area.