



GENUINE ACCESSORIES

Installation Instructions

Part Number:
0000-8E-R10

Supplemental Trailer Hitch Harness

Applicable Models:
2017 > CX-5 (GAS 2.5L)

Package Contents:



Installation
Instructions
(QTY 1)

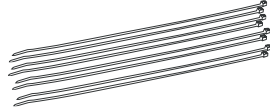

Large Tie
Wraps
(QTY 7)

Tools Required

Before Installation

A



Wire Cutters

B



Drill &
6mm Drill Bit

C

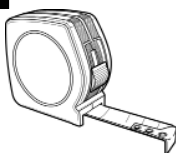

Tape
Measure

- 1.) Read installation instructions before proceeding.
- 2.) Be careful not to damage vehicle paint or kit components.
- 3.) Do not over tighten bolts, tighten to specified torque.
- 4.) Record customers preset radio stations (if applicable).
- 5.) Using a 10mm socket, remove negative (-) battery terminal.

A**4-FLAT HARNESS TIE WRAP REMOVAL**

Take caution not to damage or cut trailer hitch harness or any factory installed harnesses during the removal of the ties wraps.

Tools Needed:

Wire Cutters

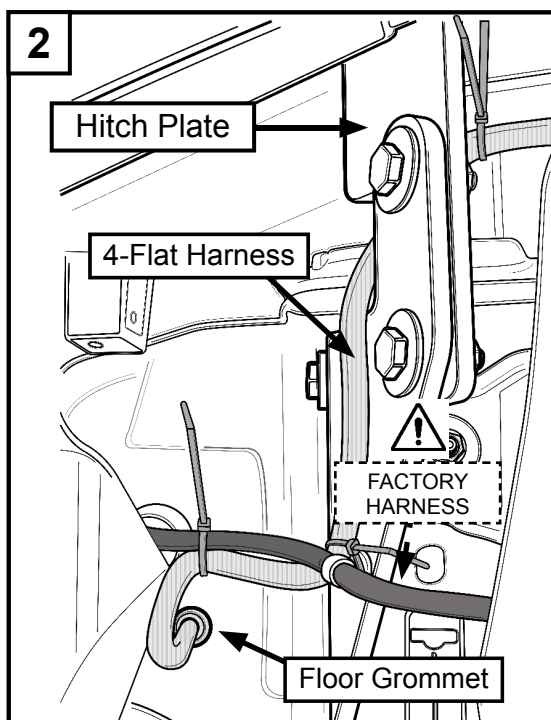
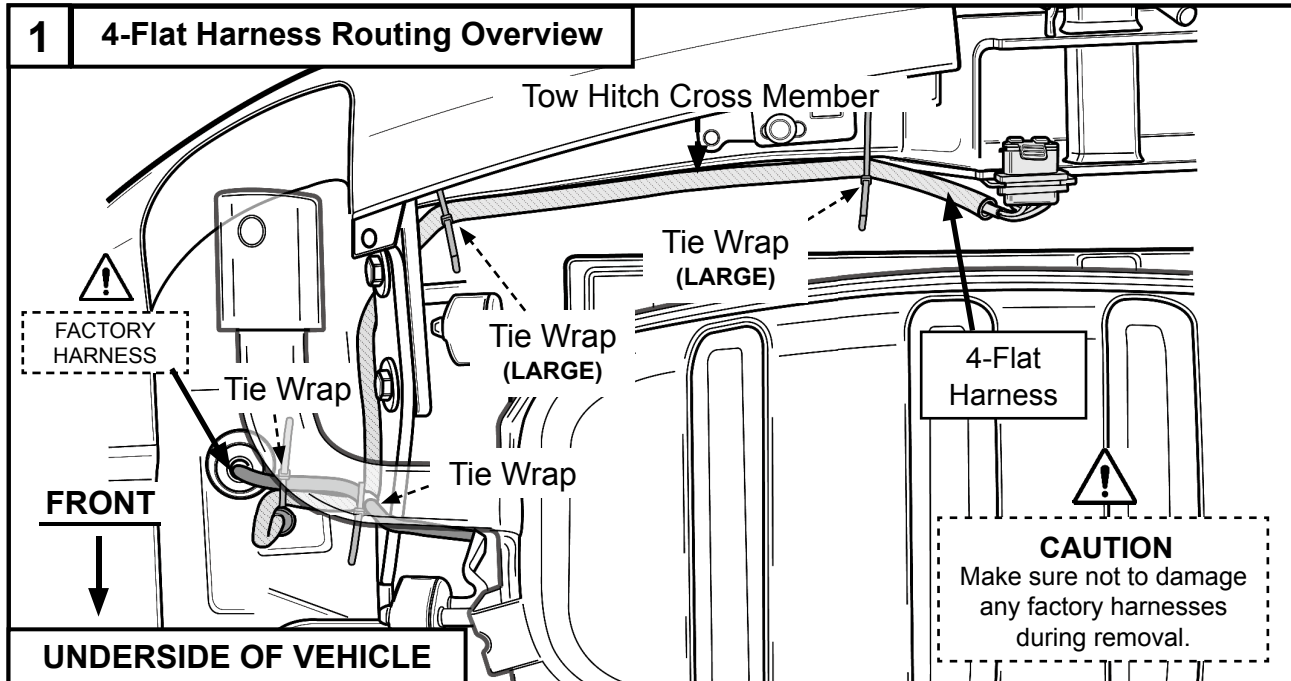

1. Underneath vehicle, cut all existing tie wraps attaching 4-Flat trailer harness to vehicle using wire cutters.
2. Leave floor grommet from interior of vehicle containing 4-Flat trailer harness seated. Do not remove.
3. Remove harness connector from hitch bracket.
4. Harness should be free at this point and only attached at grommet.

B**DRILL HOLE IN BUMPER FASCIA**

1. Locate attachment point (a) on the bumper fascia to measure the drill point for the tie wrap attachment. Measure 20mm towards the receiver tube of the hitch and 15mm upwards. Drill a 6mm hole at the drill point.

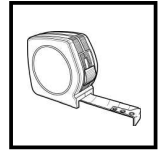
Tools Needed:

Tape Measure

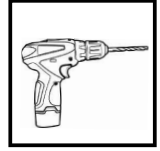

Drill + 6mm bit

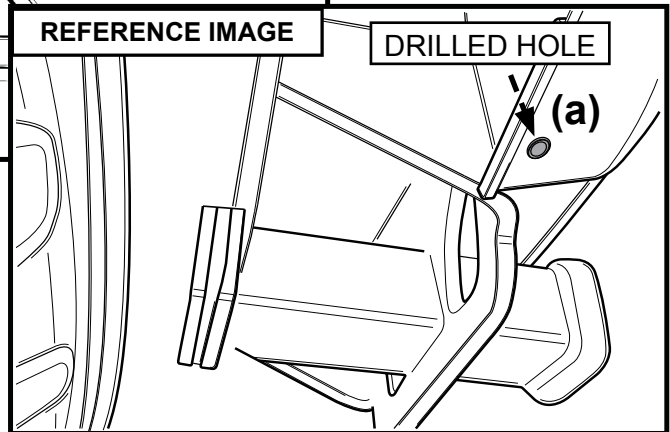
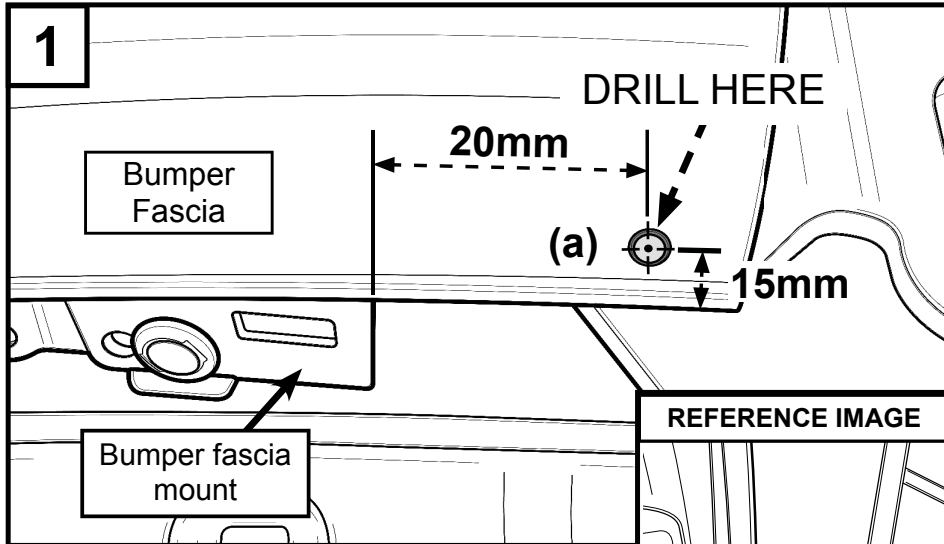
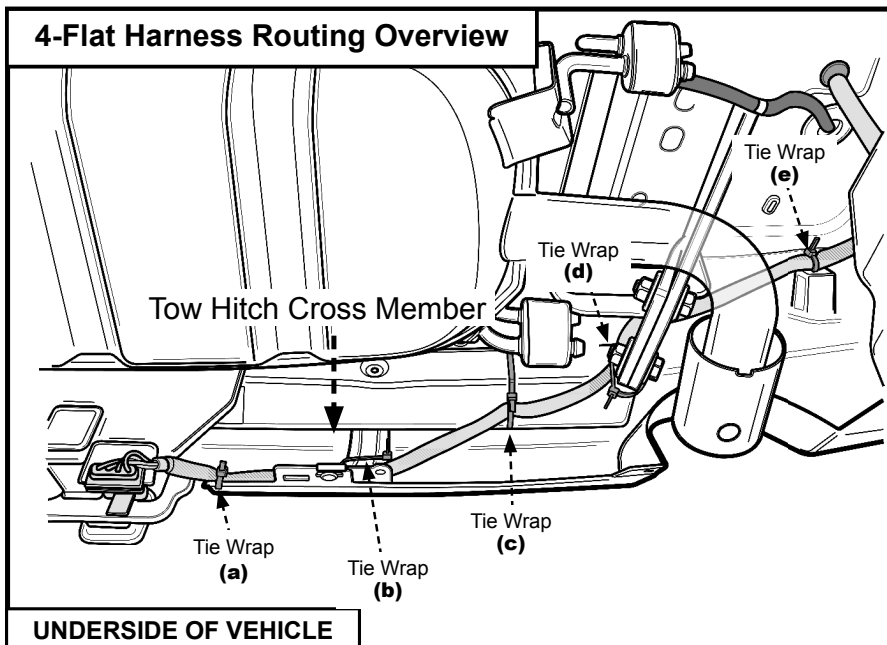
**C****4-FLAT HARNESS REROUTE TO HITCH RECEIVER**

Continues on next page

1. Starting at grommet area, route 4-Flat trailer harness over top of hitch attachment bracket in direction towards hitch receiver tube.

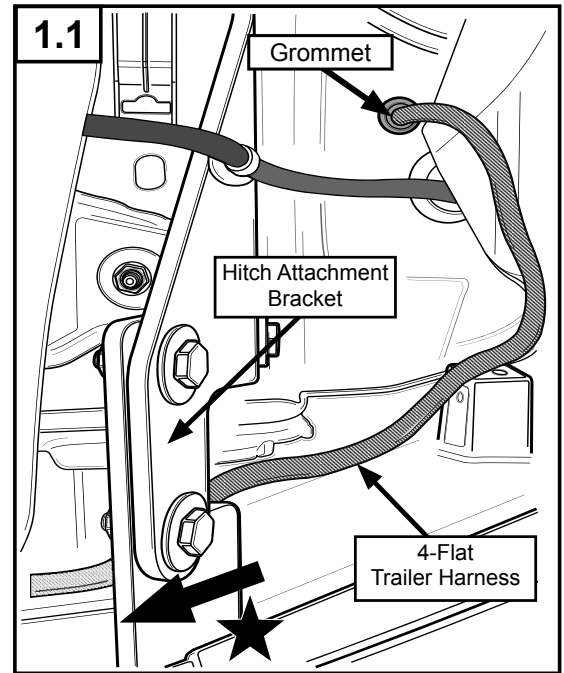
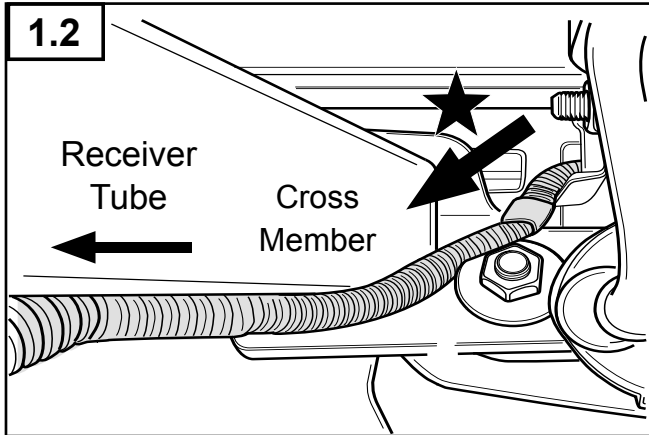

2. Route 4-Flat trailer harness underneath hitch cross member and up towards the fascia support bracket.

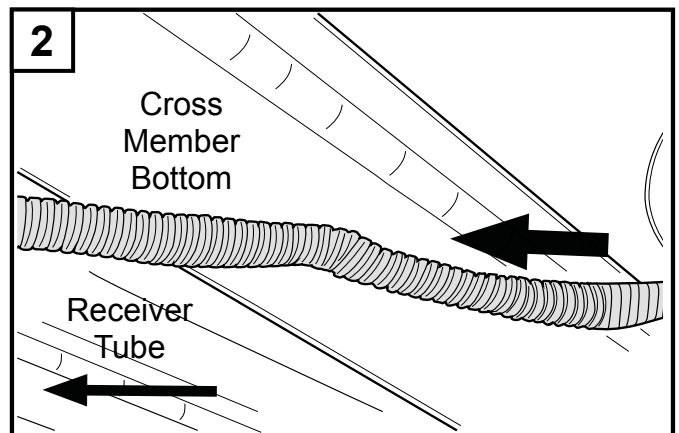

3. Route 4-Flat trailer harness behind fascia support bracket making sure the harness is routed between the bumper fascia and bracket.

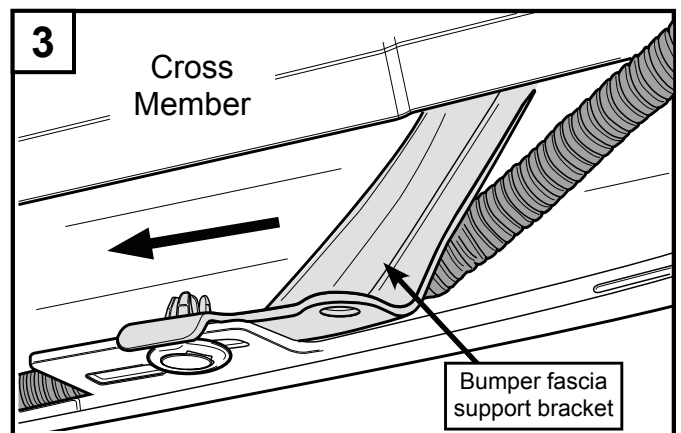

D SECURE 4-FLAT HARNESS FROM HITCH TO VEHICLE



Due to the extreme high temperatures produced by the exhaust, a minimum clearance of 50mm must be maintained between exhaust and harness. Failure to do so will result in severe damage to harness and loss of trailer functions, such as brake light and turn signal lights.

1. After performing Step 1, verify that a minimum of 50mm has been achieved between exhaust and harness. If not, remove tie wrap and repeat Step 1 above using a new tie wrap. If 50mm has been achieved, move on to Step 2.

1. Secure the 4-FLAT trailer connector into the hitch bracket as shown.

Remove all slack in the wiring towards the drilled hole (a). Use a large tie wrap to fully secure the wire harness ensuring a 50mm clearance from the indented section of the exhaust closest to the harness as shown in the measurement photo and make sure to remove all slack. It's important that the corrugated tube is routed over the edge of the bracket for protection.

Tools Needed:

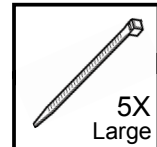

Tie Wraps

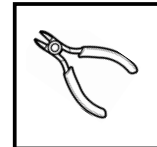

Wire Cutters

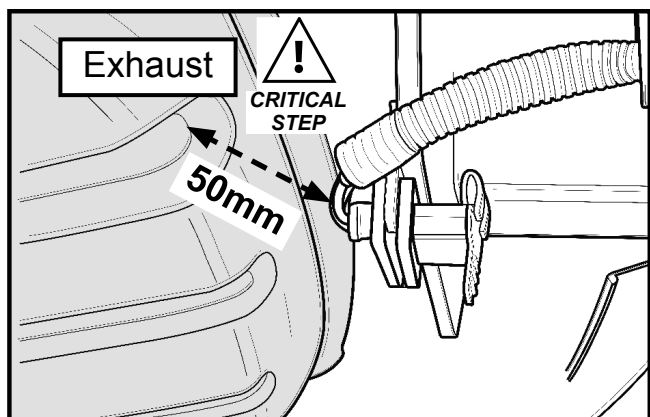
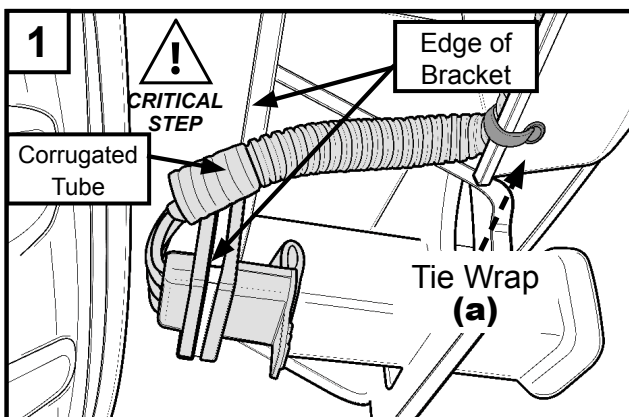
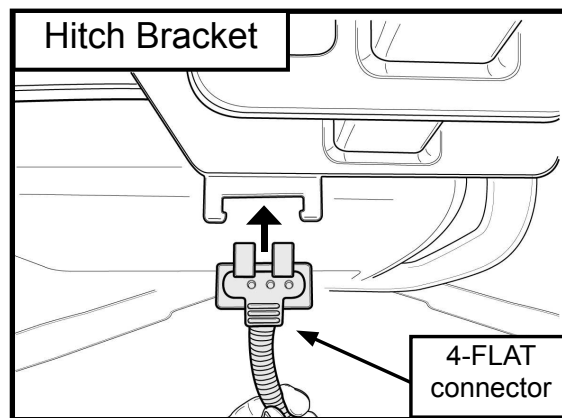

It's important that the corrugated tube is routed over the edge of the bracket for protection. Damage to harness may occur otherwise.

Continues on next page

2. After the distance verification trim the cable tie using the wire cutters and rotate the tie wrap head up so it is not visible from the rear of the vehicle to avoid injury.

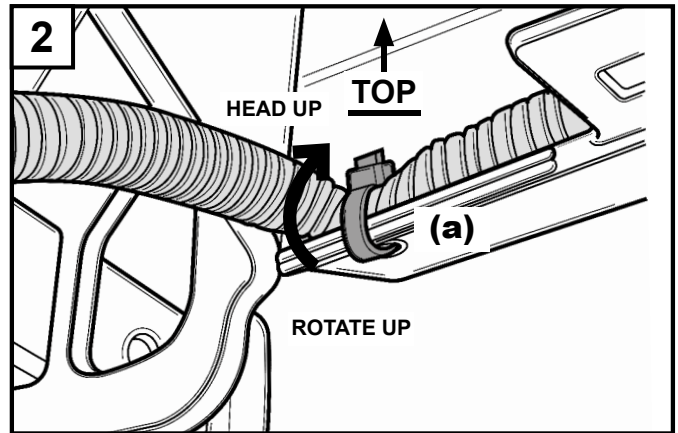

3. Confirm harness is routed between the bumper fascia and support bracket. If so, remove all slack between tie wrap location (a) and tie wrap location (b) and use a large tie wrap to secure harness to support bracket, tighten the tie wrap and trim the tie wrap tail with wire cutters.

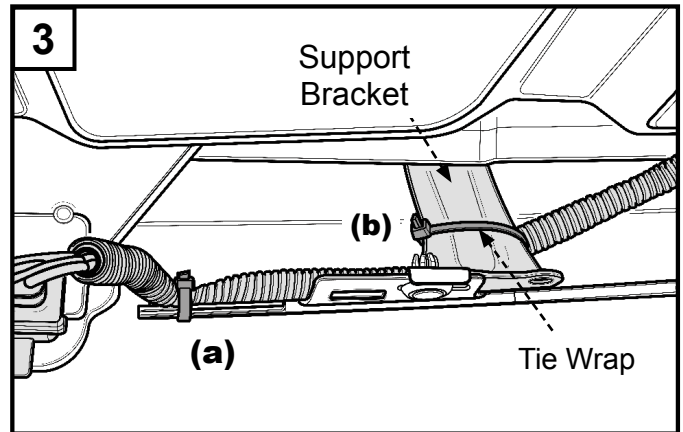

4. Use a large tie wrap (c) to secure the harness to the bottom of the cross member of the hitch. Tie wrap should be located 100mm from cross member end. Remove all slack, tighten the tie wrap and trim the tie wrap tail with wire cutters.

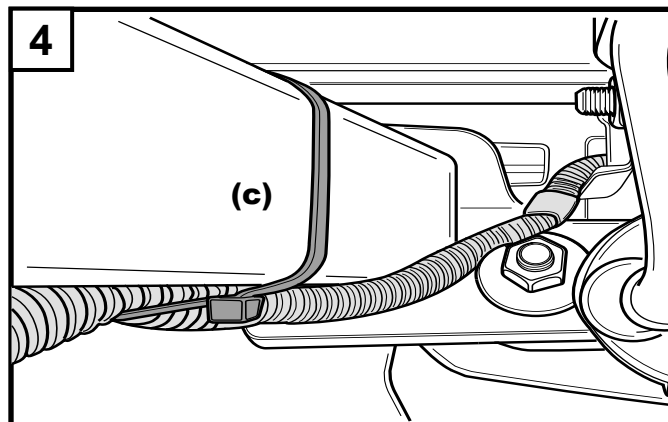
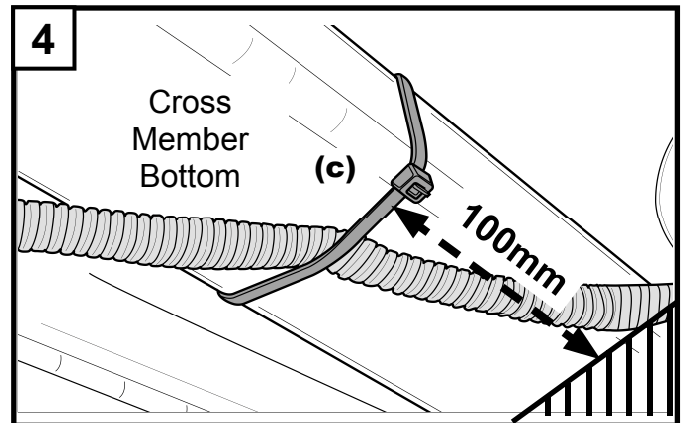

Continues on next page

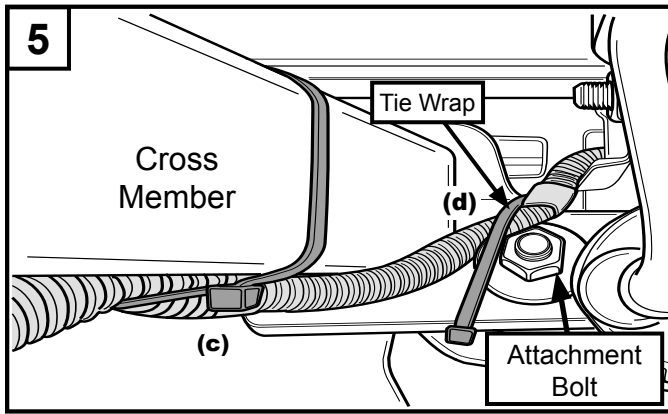

5. While removing all slack, use a large tie wrap to secure the harness to the hitch attachment bracket (d). Tighten the tie wrap and trim the tail using wire cutters.

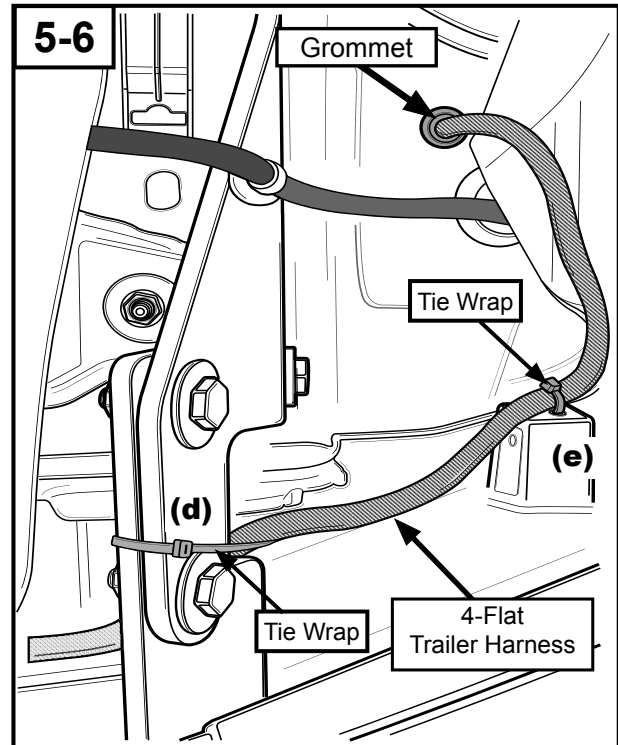

6. Remove all the slack in the harness near the wire attachment point near the grommet. This is located on the rear side of the bumper deflector (e). Use a large tie wrap to secure the harness to the attachment point. Remove all slack, tighten the tie wrap and trim the tie wrap tail using wire cutters.

E FINISHING STEPS

1. Connect negative (-) battery terminal.

TROUBLESHOOTING GUIDE

PART NUMBER:

0000-8E-R10

TRAILER HITCH WIRING KIT

APPLICABLE MODELS

2017 > CX-5 (GAS 2.5L)

TOOLS REQUIRED

TEST LIGHT

METHOD

1. Attach the test light ground connection to the male pin of the harness's 4-flat connector.
2. Probe each of the female pins individually to confirm correct circuit operation.

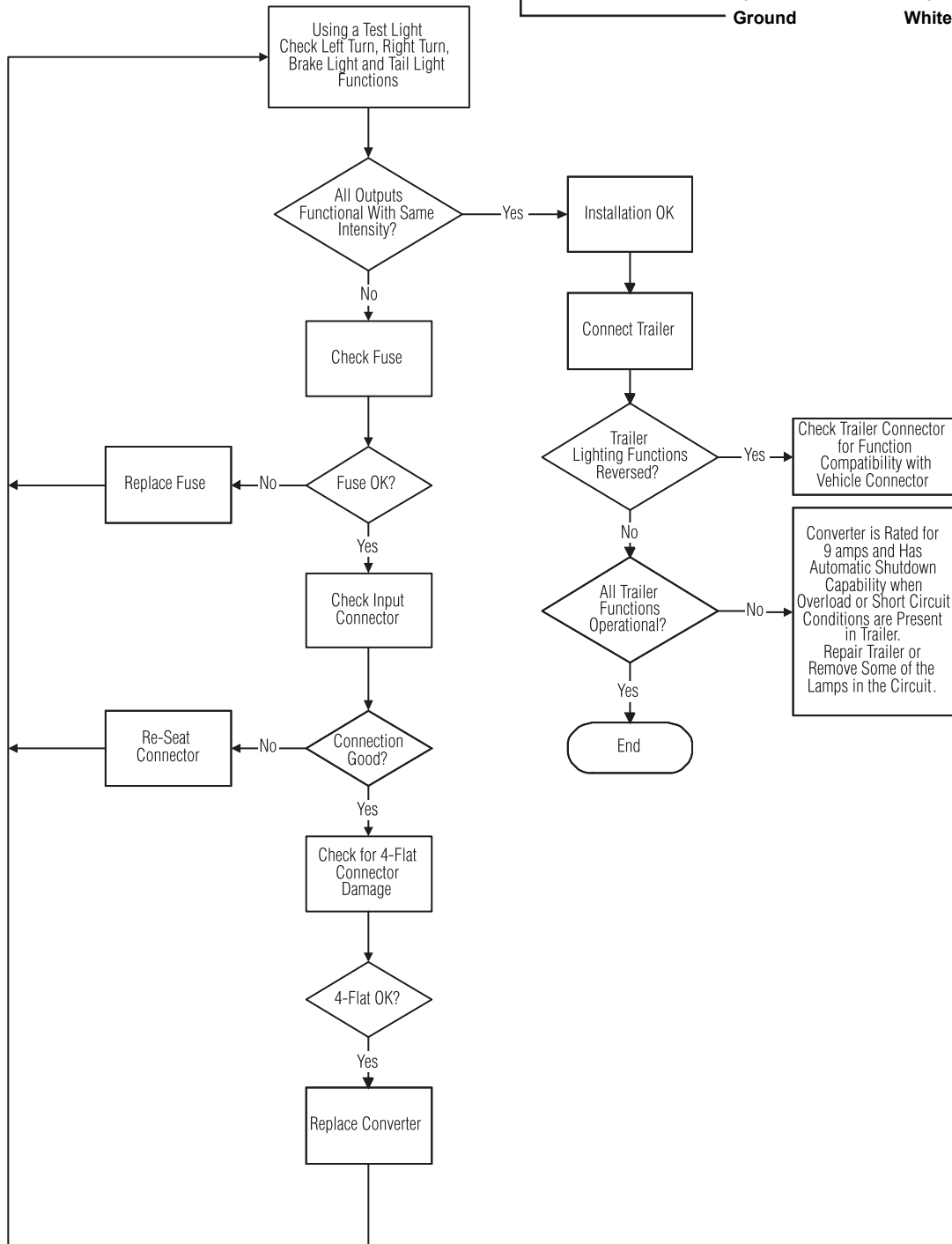
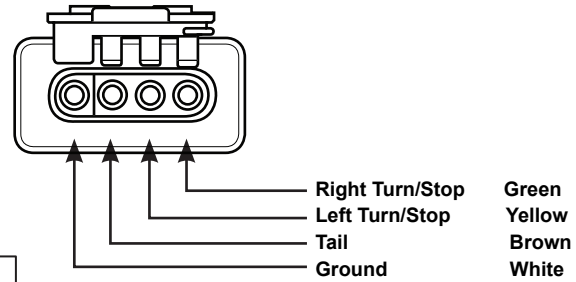

INSTALLATION INSPECTION

PART NUMBER:
0000-8E-R10

TRAILER HITCH WIRING KIT

APPLICABLE MODELS
2017 > CX-5 (GAS 2.5L)

Inspect the installed / reinstalled parts for the following items:

 CRITICAL STEP	Inspection Parts	Inspection Items •			Operation Check
		Clearance/Fit	Scratches/Dirt/ Harness Interference	Installation/ Tightening/ Engagement	
	50mm Between Exhaust & Harness	•	•	•	
	Tow Harness Functions				•
	Tow Harness	•	•	•	
	Tow Harness Module Ground Screw			•	
	Driver's Side Left Rear Interior Trim Panel	•	•	•	
	Passenger Side Right Rear Interior Trim Panel	•	•	•	
	Rear Threshold Plate	•	•	•	
	Rear Foam Inserts	•	•	•	
	Rear Floor Covering	•	•	•	
	Vehicle Negative Power Cable			•	
	4-FLAT Harness	•		•	

Notes:

1. Verify signal functionality at the trailer harness plug using test procedure on page 8.
2. Ensure tow harness module ground bolt is torqued to 7.0 N•m.

CAUTION



When the battery is disconnected, the DSC may stop operating.

(The DSC OFF indicator will flash at this time, and the TCS/DSC operation indicator will illuminate.)

1. Turn the ignition switch to "OFF" and then turn it back to "ON".
2. Turn the steering wheel clockwise as far as it will go, and then turn it back counterclockwise as far as it will go.
3. Check that the TCS/DSC operation indicator is turned off.
4. Turn the ignition switch to "OFF" and then turn it back to "ON".
5. Check that the TCS/DSC operation indicator is turned off. If the TCS/DSC operation indicator is still illuminated or the DSC indicator is not turned off when the ignition switch is turned back to "ON", contact your Mazda dealer.

CAUTION



If the battery is disconnected, the power windows may no longer fully open or fully close automatically.

1. Turn the ignition key to the "ON" position.
2. Press the power window switch to fully open the power windows.
3. Lift up the power window switch to fully close the power windows, and keep it pulled up for approximately 2 seconds.
4. Position the engine switch at "OFF", and then at "ON" again. When the function doesn't work after these procedures, please contact your Mazda dealer.

CAUTION



Due to the extreme high temperatures produced by the exhaust, a minimum clearance of 50mm must be maintained between exhaust and harness. Failure to do so will result in severe damage to harness and loss of trailer functions, such as brake light and turn signal lights.

1. After performing Step 1 on page 5, verify that a minimum of 50mm has been achieved between exhaust and harness. If not, remove tie wrap and repeat Step 2 using a new tie wrap. If 50mm has been achieved, move on to Step 3.

Date					
Vehicle					
VIN					
Approved		Checked		Person in Charge	