



RECALL CAMPAIGN BULLETIN

Reference:

NTB17-115

Date:

November 14, 2017

VOLUNTARY SAFETY RECALL CAMPAIGN 2016 ROGUE; FRONT PASSENGER SEAT

CAMPAIGN ID #: PC599

APPLIED VEHICLES: 2016 Rogue (T32)

**Check Service COMM or Dealer Business Systems (DBS)
National Service History to confirm campaign eligibility.**

INTRODUCTION

Nissan is conducting this voluntary safety recall campaign on certain specific model year 2016 Rogue vehicles to replace the front passenger seatback assembly. This service will be performed at no charge to the customer for parts or labor.

IDENTIFICATION NUMBER

Nissan has assigned identification number PC599 to this campaign. This number must appear on all communication and documentation of any nature dealing with this campaign.

DEALER RESPONSIBILITY

It is the dealer's responsibility to check Service COMM or Dealer Business Systems (DBS) National Service History for the campaign status on each vehicle falling within the range of this voluntary safety recall which for any reason enters the service department. This includes vehicles purchased from private parties or presented by transient (tourist) owners and vehicles in a dealer's inventory. **Federal law requires that new vehicles in dealer inventory which are the subject of a safety recall must be corrected prior to sale. Failure to do so can result in civil penalties by the National Highway Traffic Safety Administration.** While federal law applies only to new vehicles, Nissan strongly encourages dealers to correct any used vehicles in their inventory before they are retailed.

Nissan Bulletins are intended for use by qualified technicians, not 'do-it-yourselfers'. Qualified technicians are properly trained individuals who have the equipment, tools, safety instruction, and know-how to do a job properly and safely. NOTE: If you believe that a described condition may apply to a particular vehicle, DO NOT assume that it does. See your Nissan dealer to determine if this applies to your vehicle.

REQUIRED SPECIAL TOOL (J-52352)

Quick Scan Tool (J-52352)

- Each dealer has been shipped one Quick Scan Tool (J-52352).
- Additional tools can be obtained from Tech•Mate at 1-800-662-2001.



Figure A1

SERVICE PROCEDURE

NOTE: The Service Procedure in this campaign bulletin differs from the one in the Electronic Service Manual (ESM). Follow this procedure exactly as described.

New Module Registration

1. Register the new side air bag module (module) serial number as follows.
 - The new module is part of the front passenger seat seatback assembly, which is listed in **PARTS INFORMATION**.

- a. Attach the quick scan tool (J-52352) to your CONSULT PC USB port.



Figure A2

- b. On the left side of the ASIST main menu, select **Tech Support Info**, then **Inventory Vehicle Actions**.

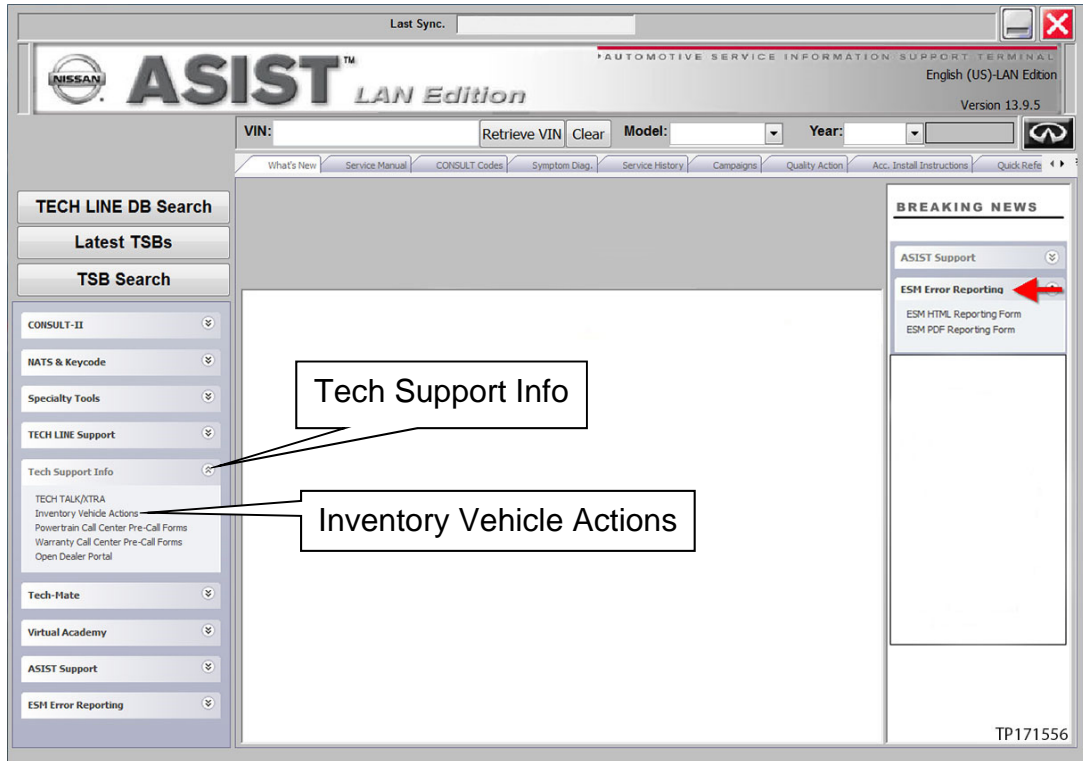

Figure A3

- c. Select **CLICK HERE** ("AirBag to VIN Registration").

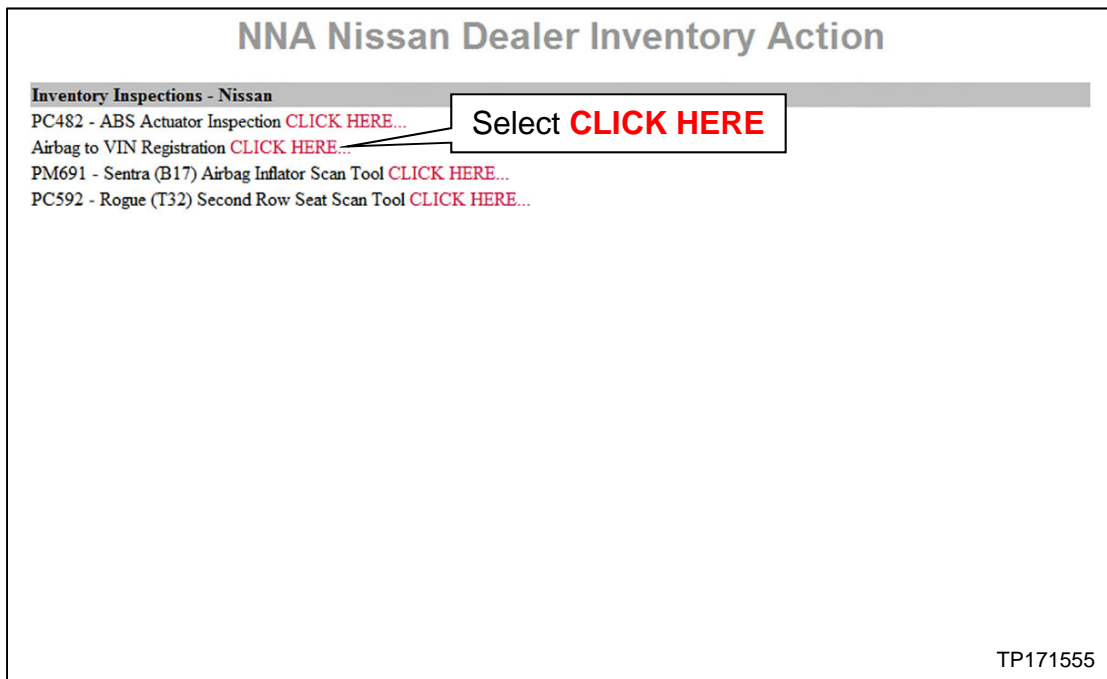
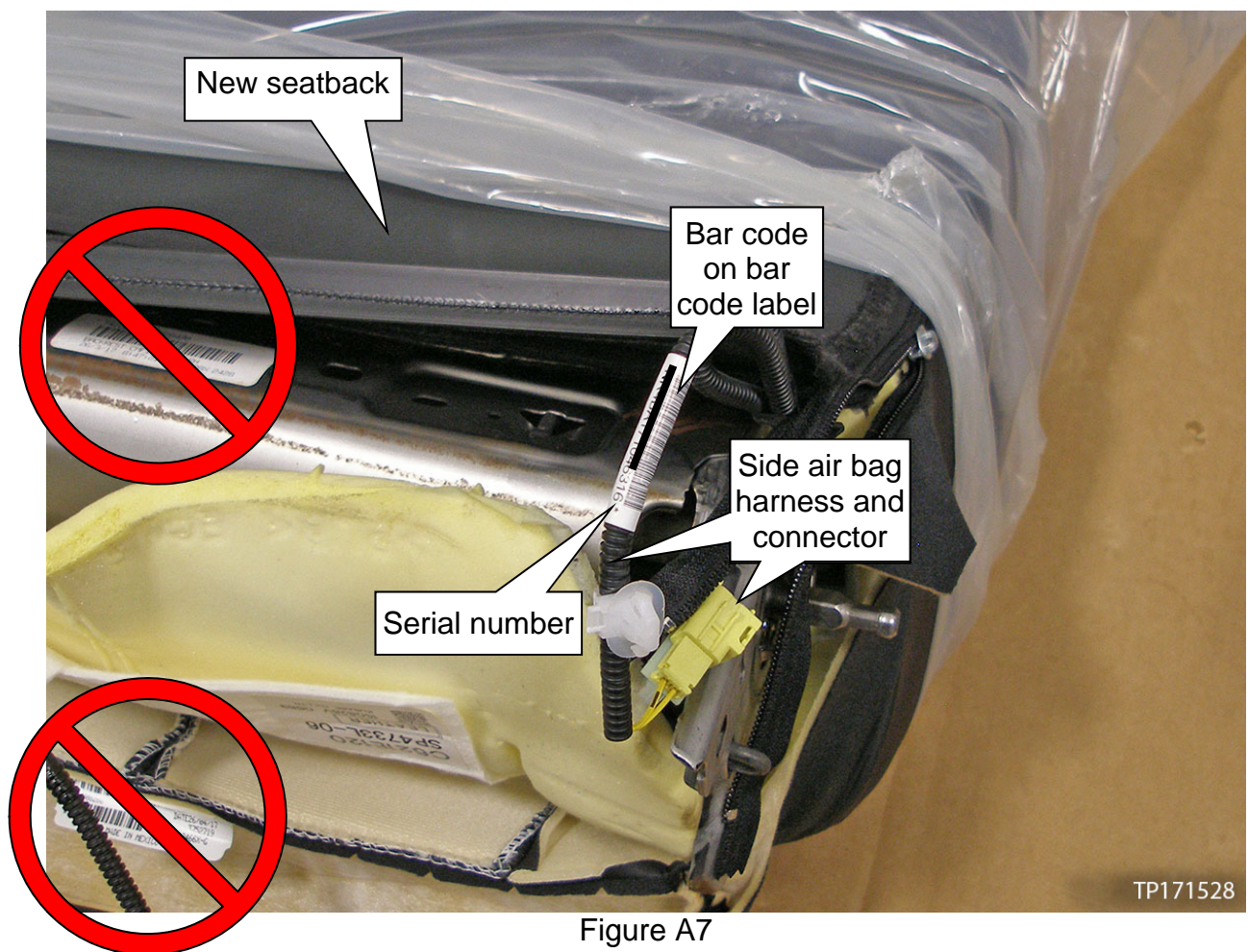

Figure A4

- e. Use the quick scan tool to scan the bar code (serial number) on the new module.
- Access the bar code label (see Figure A7).
 - Hold the scan tool approximately 6 inches away from the bar code label.
 - The serial number will automatically populate (see Figure A6 on previous page).

NOTE: If needed, the serial number can be entered manually.



- f. Select **Submit** on the ASIST screen (see Figure A6 on the previous page).

Front Passenger Seat Seatback Assembly: Replacement

WARNING: This procedure involves working on the front passenger seat. The metal seat frame has sharp edges.

CAUTION: Handle interior trim carefully to avoid damage. Work with clean hands and clean tools to avoid dirt and stains. Position clean suitable covering in the vehicle where work is being performed. Perform repairs in a clean working area on a soft surface, such as a fender cover, cardboard, etc.

IMPORTANT: Follow all cautions, warnings, and notes in the Electronic Service Manual (ESM) when working on or near a Supplemental Restraint System (SRS), such as an air bag or OCS components.

1. Turn the ignition ON with engine OFF.
2. Write down the audio settings.

Presets	1	2	3	4	5	6
AM						
FM 1						
FM 2						
SAT 1						
SAT 2						
SAT 3						
Bass	Treble	Balance	Fade	Speed	Sen.	Vol.

3. If equipped: Write down the customer preferred setting for the automatic air conditioning (auto-air) system.
 - Refer to the ESM, section HAC-Heater & Air Conditioning Control System, for auto-air system settings access.
4. Disconnect the battery cables, negative cable first, and then wait for at least three (3) minutes.
5. Remove the front passenger seat (seat).
 - Refer the ESM, section SE-Seat, for seat removal.
6. Place the seat on its left side.
7. Unfasten the two (2) J-hooks shown in Figure 1.

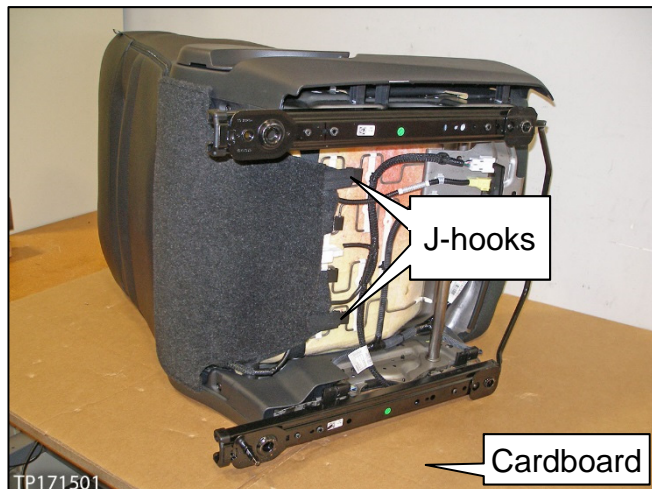

Figure 1

- Tuck the seat flap in the rear seat pocket.



Figure 2

8. Remove the recline lever.

- Using a suitable tool, remove the clip, and then remove the recline lever.

WARNING: Wear eye protection. When removing, this clip may eject as a projectile.

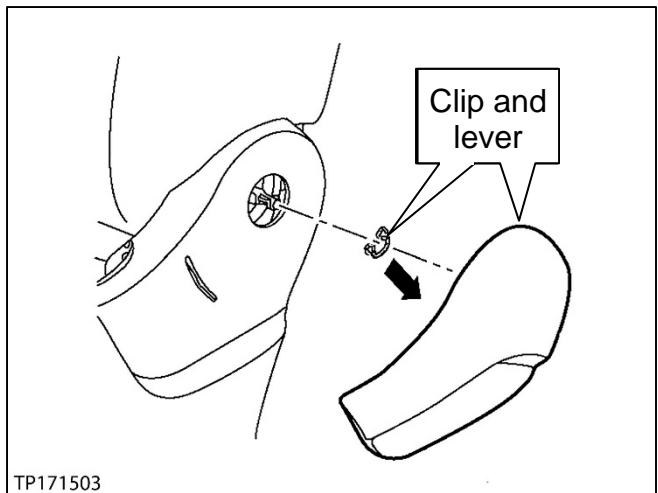

Figure 3

- To keep from losing the clip, fasten it onto the recline lever now.
 - This clip can be left on. When reinstalling, the recline lever only needs to be pushed back on its square shaft.

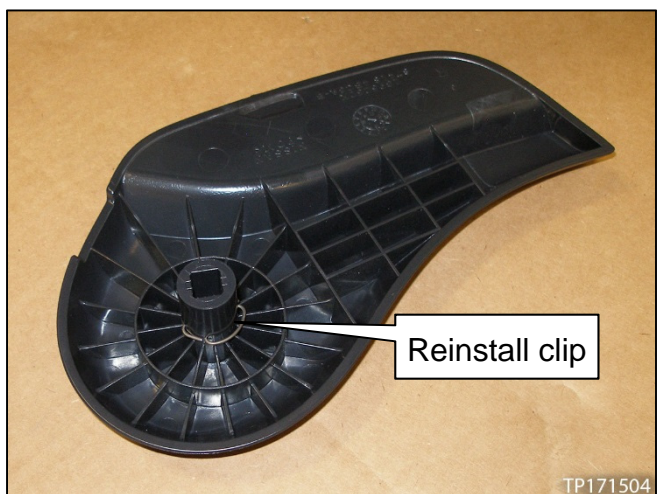

Figure 4

9. Remove the seat cushion outer finisher RH with a suitable plastic trim tool as follows:

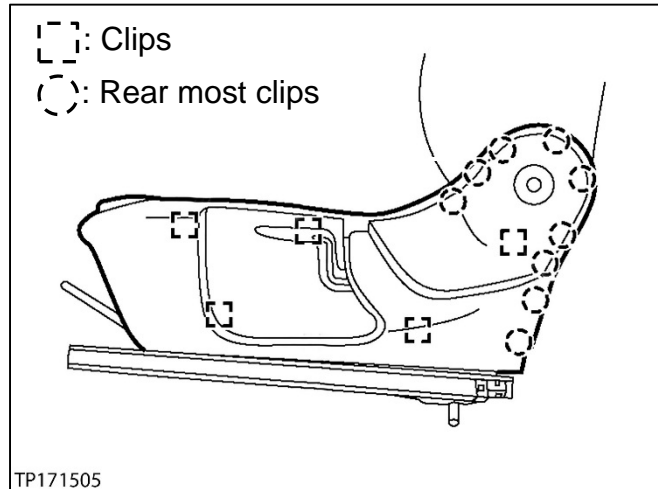

Figure 5

- a. Start by unsnapping the two (2) clips at the front of the finisher with a suitable plastic trim tool.



Figure 6

- b. Unsnap the remaining clips with exception of the rear most clips.



Figure 7

- c. Unsnap the rear most clips with a suitable plastic trim tool.



Figure 8

NOTE: Some of the metal or plastic clips may stay lodged in the lower seat frame. Remove, and then reinstall the clips on the seat cushion outer finisher RH now.

- See Figure 9 and 10.



Figure 9

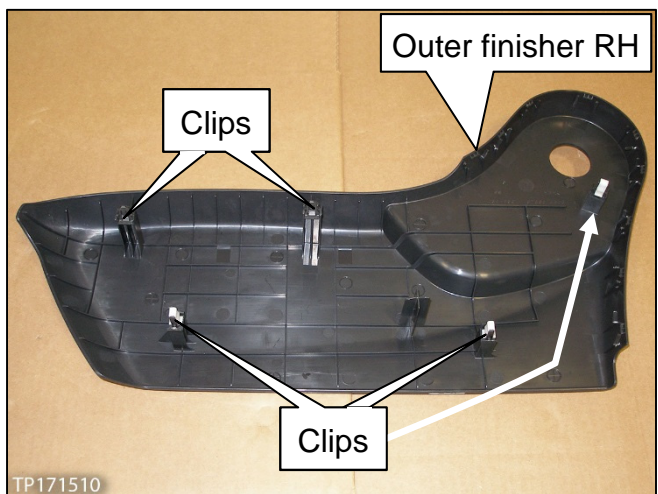

Figure 10

10. Remove the screw, and then remove the seat cushion inner finisher RH.

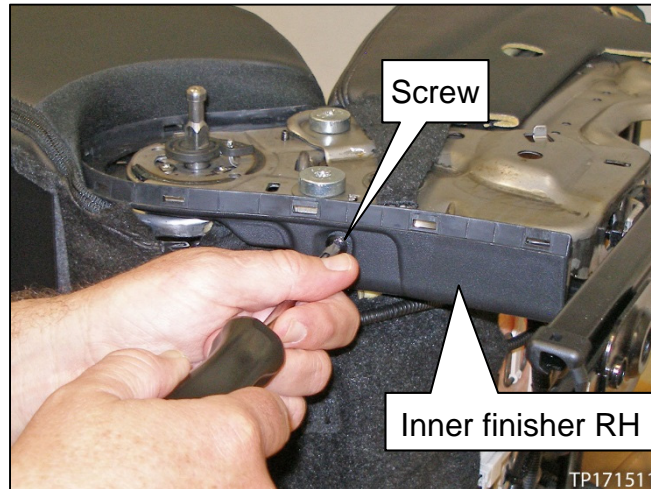

Figure 11

11. Place the seat on its right side.

12. Remove the seat cushion outer finisher LH with a suitable plastic trim tool.

NOTE: To access the finisher, the seatback may need to be reclined back.

- To remove the finisher, slightly pry outward on the seat belt buckle.

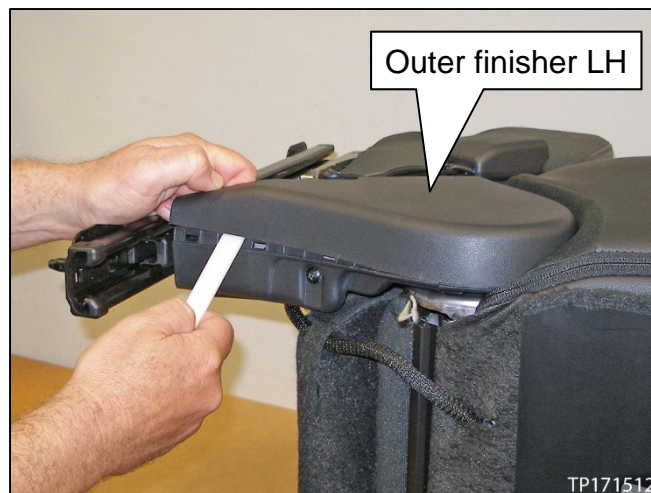

Figure 12

13. Remove the screw, and then remove the seat cushion inner finisher LH.



Figure 13

14. Place the seat in a position to access underneath.

15. Unfasten the two (2) J-hooks shown in Figure 14.

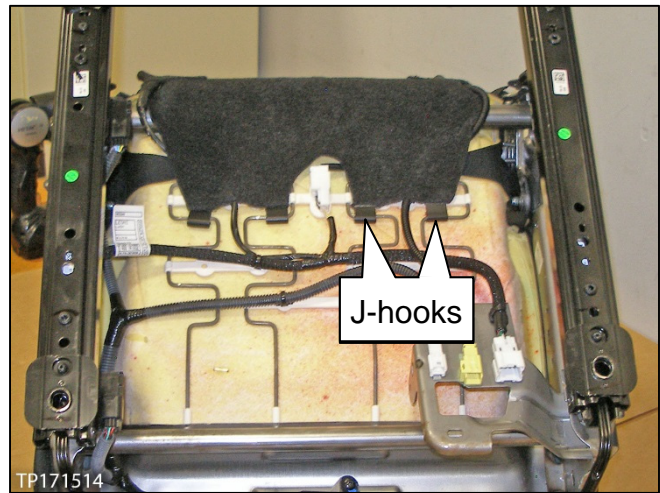

Figure 14

16. Unfasten the four (4) side air bag electrical harness and connector clips, and hook-and-loop fastener (see Figure 15 and 16).

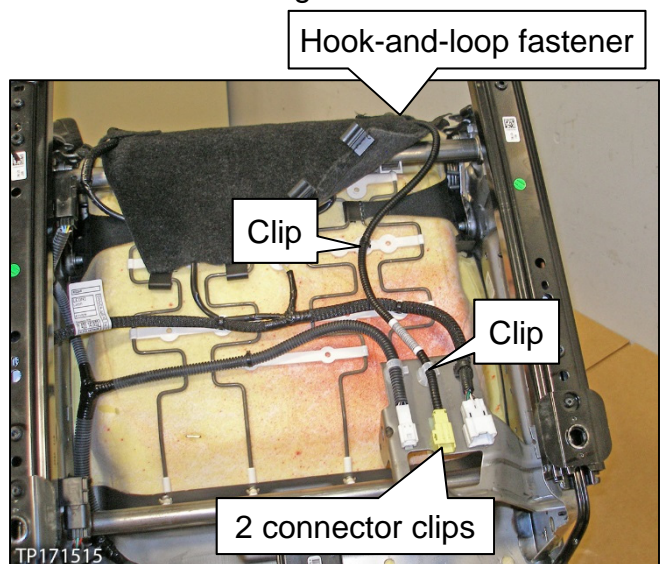

Figure 15



Figure 16

- Loosely tie a knot in the harness to help keep it from getting in the way.

17. Start unfastening the long J-hooks from each other at one end with a suitable tool such as a narrow flat blade screwdriver.

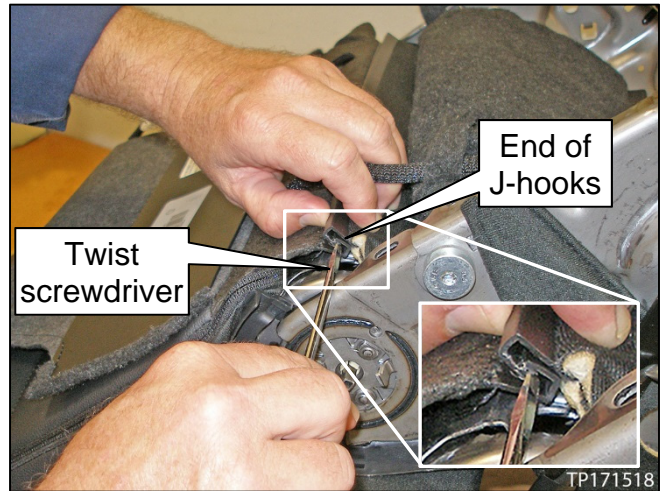

Figure 17

18. Once started, completely unfasten the J-hooks by pulling apart.

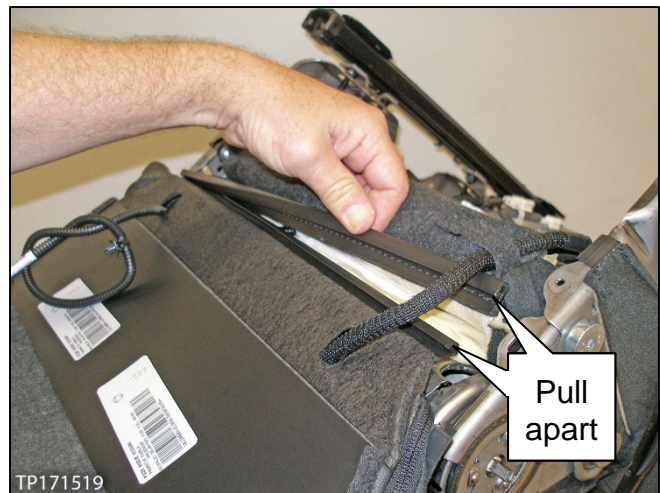

Figure 18

19. Unzip both seatback trim zippers with a suitable tool such as a hooked pick.

- The zipper RH is shown in Figure 19. The zipper LH is not shown, but is similar.

CAUTION: Be careful not to scratch or tear seat trim.

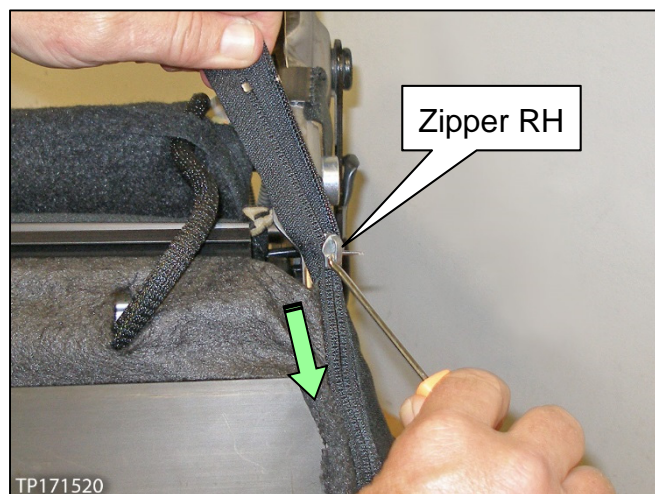

Figure 19

20. Unfasten the seat heater electrical harness from the seat cushion assembly as follows:

- a. Unclip the seat heater electrical connector from the seatback frame assembly.
- b. Disconnect the seat heater electrical connector (picture not shown).

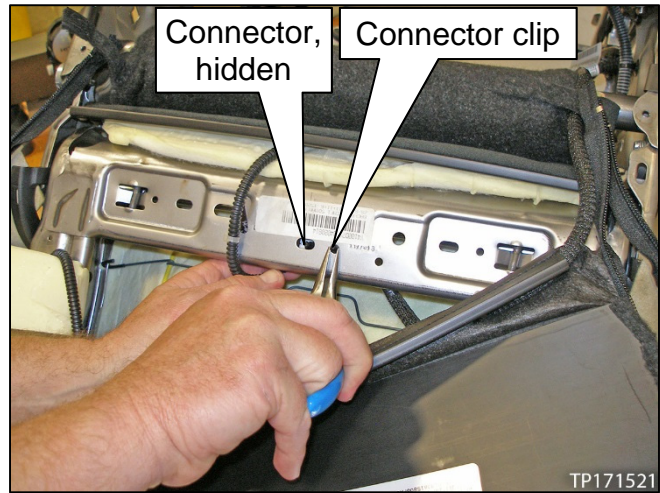

Figure 20

- c. Pull the seat heater electrical harness with connector through the seat flap.

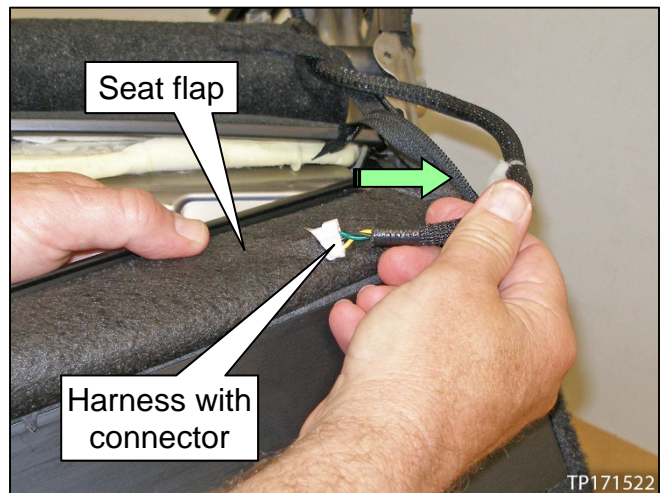

Figure 21

21. Place the seat in the upright position.

22. Remove the four (4) T40 TORX® seatback assembly bolts.

- If the TORX® portion strips out, use suitable locking pliers to remove the bolt(s).
- These bolts will be replaced with new ones. Do not reuse the old bolts.

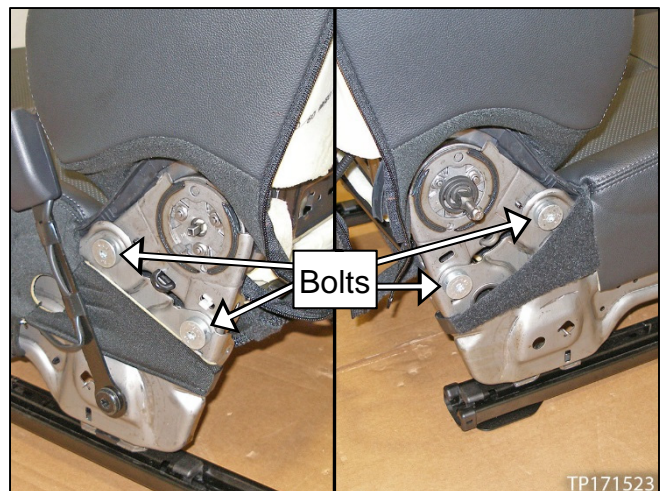

Figure 22

23. Remove the seatback assembly and lay it down (on a clean surface) on its front side.

NOTE: Perform steps 24-26 on the seatback assembly just removed.

24. Unfasten the seat heater electrical harness clip.

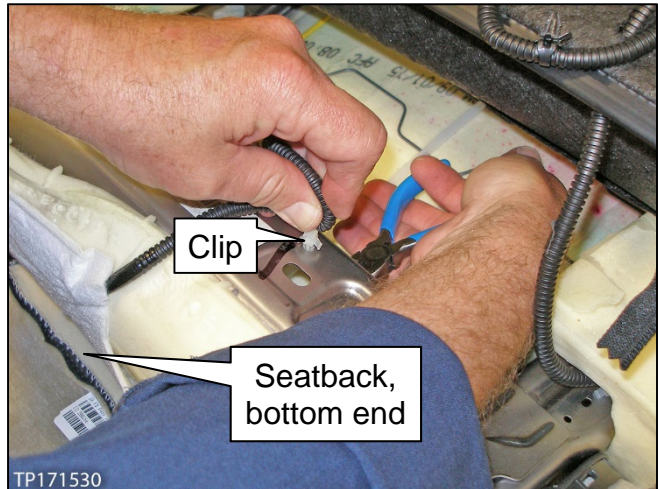

Figure 23

25. Remove the seat cushion inner finisher LH screw.

- To access this finisher, fold down the seatback foam/trim.

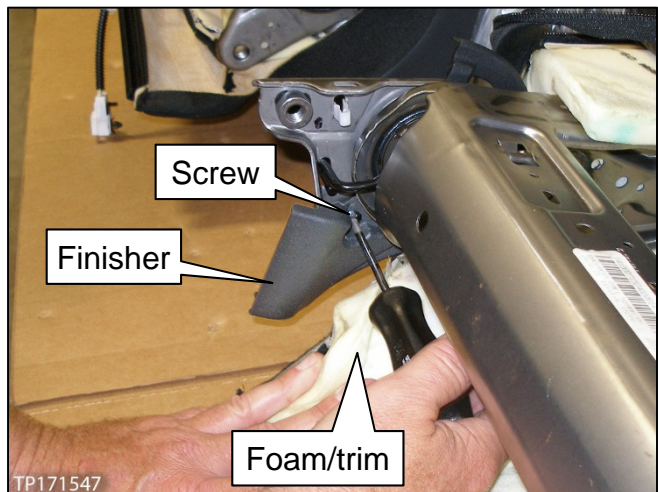

Figure 24

26. Remove the seat cushion inner finisher RH screw.

- To access this finisher, fold down the seatback foam/trim.

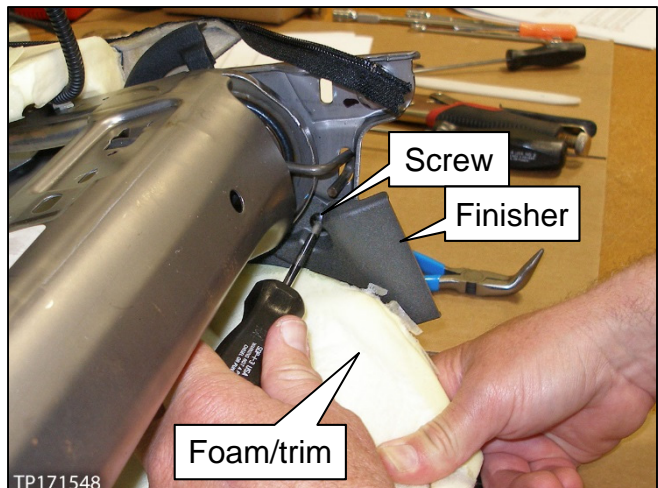

Figure 25

27. Remove both finishers.

- a. Carefully pull the finisher end away from the seatback as shown in Figure 26.
- b. Rotate the finisher rearward (as shown in Figure 26), and then remove it from the seatback.

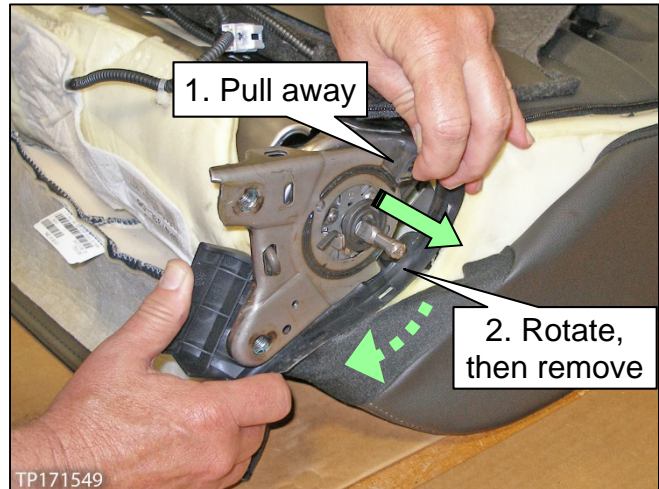

Figure 26

28. Assemble and install the new seatback in reverse order of seatback removal/disassembly (pages 6-15).

- Before assembly/installation, verify the new seatback matches the old one.
- T40 TORX® bolts torque: 35 N•m (3.6 kg-m, **26 ft-lbs**)

29. Install the seat.

- Refer to the ESM, section SE-Seat, for seat installation.
- Seat-to-floor bolts torque: 40 N•m (4.1 kg-m, **30 ft-lbs**)
- See Figure 27 for seat-to-floor bolts torque sequence.

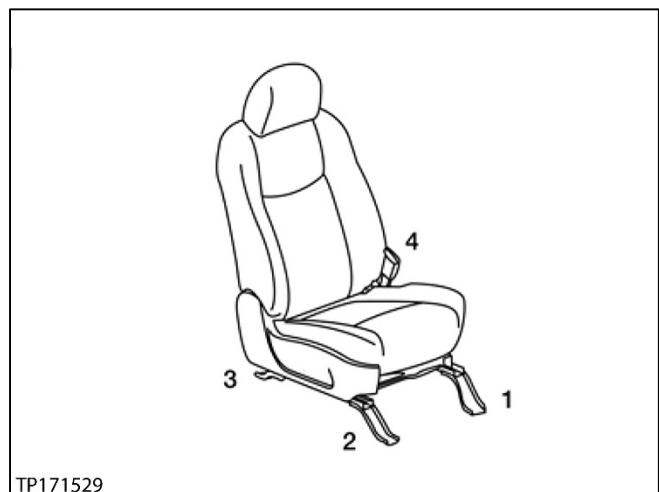

Figure 27

30. Reconnect the battery cables, positive cable first.

31. Perform Zero Point Reset.

- Refer to the ESM, section SRC-SRS Airbag Control System, for Zero Point Reset procedure.

32. Reset/reinitialize systems as needed.

- Refer to the ESM, section PG-Power Supply, Ground & Circuit Elements, for a listing of systems that require reset/initialization after reconnecting the 12 V battery.
- Look in the PG section index for **ADDITIONAL SERVICE WHEN REMOVING BATTERY NEGATIVE TERMINAL**.
- This list often includes items such as the radio, power windows, auto-air, sunroof, etc.

PARTS INFORMATION

DESCRIPTION	CONFIGURATION	PART NUMBER	QUANTITY
BACK ASSY-FRONT SEAT RH	G /cloth/heated *	87600-4BC2A	1 only
BACK ASSY-FRONT SEAT RH	C /cloth/heated **	87600-4BC2B	
BACK ASSY-FRONT SEAT RH	G /cloth/non-heated *	87600-4BC8A	
BACK ASSY-FRONT SEAT RH	C /cloth/non-heated **	87600-4BC8B	
BACK ASSY-FRONT SEAT RH	G /leather/heated *	87600-4BL3A	
BACK ASSY-FRONT SEAT RH	C /leather/heated **	87600-4BL3B	
BOLT (T40 TORX® bolt)	- -	86899-5HA0A	4

* **G** = Charcoal

** **C** = Almond

CLAIMS INFORMATION

Submit a “CM” line claim using the following claims coding:

CAMPAIGN (“CM”) ID	DESCRIPTION	OP CODE	FRT
PC599	Replace Front Passenger Seatback Assembly	PC5990	1.0