



Date: November 02, 2017

TECHNICAL SERVICE BULLETIN

Indian Motorcycle

Bulletin Number: I-17-03-A/B/C
Model Years: 2017-18

Safety Bulletin

Service Bulletin

Service Alert Fax

This Service Bulletin is located at www.polarisdealers.com and www.intl.polarisdealers.com

–Confidential and Proprietary –

VERSION: R01 (November 02, 2017)

IMPORTANT STOP SALE SAFETY NOTICE!

STOP SELLING ALL AFFECTED INDIAN MOTORCYCLES IMMEDIATELY UNTIL THE REPAIR PROCEDURE HAS BEEN COMPLETED ON ALL AFFECTED UNITS AT YOUR DEALERSHIP. Federal law prohibits the sale of products subject to a recall. Selling such products could subject the seller to substantial penalties.

IMPORTANT

If you are working with a printed copy, please verify you have the most current version of these instructions.

SUBJECT: 2017-18 Indian (111 c.i.) Headlight Compliance

PURPOSE:

Indian Motorcycle has determined that some motorcycles equipped with halogen headlights may have been assembled using a non-compliant headlight not matching destination market requirements. Affected motorcycles, designated for sale in North America, may be equipped with an E4 (European) headlight assembly and are not considered compliant per NHTSA standards. Conversely, certain International models may be equipped with an SAE (North America spec) headlight, which is considered non-compliant per ECE standards. The E4 and SAE headlights have different photometric and marking requirements which must be inspected and, if necessary, replaced with the correct headlight.

AFFECTED MODELS:

Model Year	Models	Vehicle Identification Number (VIN) Range
2017-18	Chief, Chief Classic, Chief Dark Horse, Chief Vintage	Reference "Unit Inquiry" on the dealer website or the Service Bulletin list on the STOP site to lookup affected units.
	Springfield, Springfield Dark Horse	
	Chieftain, Chieftain Classic, Chieftain Dark Horse, Chieftain Limited, Chieftain Elite	

CUSTOMER NOTIFICATION:

Dealers are required to review their sales records and make arrangements with customers for Bulletin completion. In addition to consumer units, dealers are required to inspect, and if found to be non-compliant, correct any affected units in their inventory. Indian Motorcycle will be mailing a notification letter to consumers affected by this Bulletin in the United States and Canada.

WARRANTY CLAIM / PARTS INFORMATION:

Bulletin parts are excluded from the standard RMA policy and cannot be returned. An Initial Recommended Order Quantity has not been provided for this bulletin because the vast majority of vehicles on this bulletin are expected to be compliant and will not require parts or repair. For more details, refer to University of Polaris training course “Polaris Item Availability and Daily Ordering” and click on “Bulletin Ordering Training”.

2017-18 Indian Motorcycle (111 c.i.) w/ Halogen Lights - INSPECTION	
Safety Bulletin #	I-17-03-A
Claim Type	SB (Service Bulletin)
Labor Allowance	0.2 hrs (12 minutes)
Part Number / Description	7170107 (QTY 1) BULLETIN COMPLETION DECAL
Parts Availability	NA
University Of Polaris Video Training Requirement	NO ¹

¹ Indian Motorcycle does not require one person from a dealership to be certified before parts ordering may occur and two people from a dealership to be certified before warranty claims may be processed.

2017-18 Indian Motorcycle (111 c.i.) w/ Halogen Lights – REPLACEMENT (North America)	
Safety Bulletin #	I-17-03-B
Claim Type	SB (Service Bulletin)
Labor Allowance	0.4 hrs (24 minutes)
Part Number / Description	2412821 (QTY 1) ASM-HOUSING, DUAL HALOGEN, North America 7170107 (QTY 1) BULLETIN COMPLETION DECAL
Parts Availability	Limited availability until December 4 th , 2017
University Of Polaris Video Training Requirement	NO ¹

¹ Indian Motorcycle does not require one person from a dealership to be certified before parts ordering may occur and two people from a dealership to be certified before warranty claims may be processed.

2017-18 Indian Motorcycle (111 c.i.) w/ Halogen Lights – REPLACEMENT (Europe)	
Safety Bulletin #	I-17-03-C
Claim Type	SB (Service Bulletin)
Labor Allowance	0.4 hrs (24 minutes)
Part Number / Description	2412820 (QTY 1) ASM-HOUSING, DUAL HALOGEN, Europe 7170107 (QTY 1) BULLETIN COMPLETION DECAL
Parts Availability	Limited availability until December 4 th , 2017
University Of Polaris Video Training Requirement	NO ¹

¹ Indian Motorcycle does not require one person from a dealership to be certified before parts ordering may occur and two people from a dealership to be certified before warranty claims may be processed.

ACCESSORY REMOVE & REPLACE LABOR:

Indian Motorcycle will cover labor for the removal and installation of accessories required to complete the bulletin work. Follow the steps below to obtain reimbursement.

For accessory removal and installation up to 30 minutes of labor

Enter the actual labor time for the removal and installation into the Accessory R&R Min Field on the bulletin claim.

For accessory removal and installation over 30 minutes of labor:

1. Start a new Ask Polaris Case, Service & Warranty Question > Authorization: Non-Cosmetic & Polaris ESC or Authorization: Out of Warranty.
2. Enter your contact information and VIN, along with miles and hours into the applicable fields.
3. Enter "I-17-03" in the CONCERN and CAUSE fields. In the CORRECTION field, enter "ACCESSORY REMOVAL AND INSTALLATION".
4. Enter warranty fail codes 127/478/151.
5. Add part 0000541, quantity 1
6. Attach photos of the vehicle and accessories sufficient to support the labor time requested.
7. Submit the case to Indian Motorcycle.

BULLETIN CONTACT LIST & SCHEDULING TOOL:

A scheduling tool is available for dealers to keep a record of customers contacted and scheduled for bulletin repairs. This optional tool provides visibility for your dealership and will be helpful to track the status of scheduled service. For more information, log in to <http://www.universityofpolaris.com>

PARTS RETURN OR DISPOSAL INFORMATION:

Under no circumstances shall the parts removed in this repair be re-used, sold, or re-purposed for another application. It is your dealership / distributor's responsibility to make sure every part replaced (related to this bulletin) is taken out of circulation and disposed of properly.

WARRANTY COVERAGE PERIOD:

This Bulletin will begin November 02, 2017. This bulletin has no expiration date.

FEEDBACK FORM:

A feedback form has been created for the technician to provide Indian Motorcycle with an overall satisfaction rating for the instructions, provide comments on your experience or upload pictures/videos from a specific repair. This feedback form is viewable on a mobile device by scanning the QR code shown or by clicking **HERE** if viewing this document electronically.



HEADLIGHT INSPECTION:

1. Look at the headlight from the front of the motorcycle.

For North America motorcycles, look in the 4 o'clock position, the letters "SAE" must be visible.

- **SAE** marking indicates North America headlight
- If you are inspecting a North America motorcycle and the SAE marking is confirmed, proceed to step 2 and file I-17-03-A.
- If non-compliant, proceed to the appropriate **HEADLIGHT REPLACEMENT** procedure.



For European motorcycles, look in the 9 o'clock position, the marking "E4" must be visible.

- **E4** marking indicates European headlight
- If you are inspecting a European motorcycle and the E4 marking is confirmed, proceed to step 2 and file I-17-03-A.
- If non-compliant, proceed to the appropriate **HEADLIGHT REPLACEMENT** procedure.



2. File a warranty claim for I-17-03-A and install a completed Service Bulletin Completion Decal (7170107).

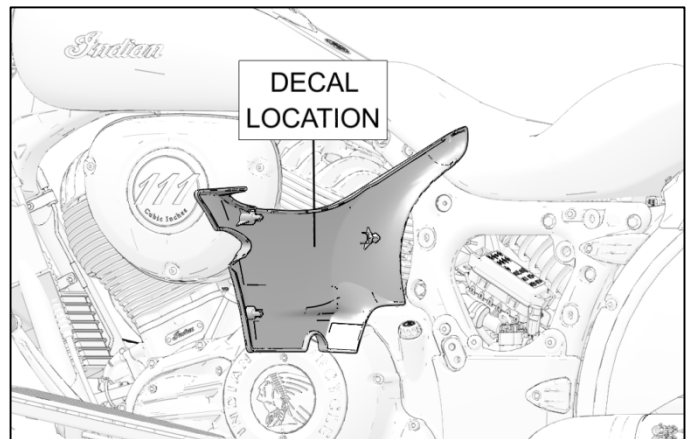

HEADLIGHT REPLACEMENT:

Tools Required:

- 4 mm, 5 mm, 6 mm allen sockets
- Philips head socket adapter
- In-lb torque wrench
- Ft-lb torque wrench
- Ratchet

Chief / Chief Classic / Chief Vintage / Chief Dark Horse / Springfield / Springfield Dark Horse Models:

CAUTION

Protect painted surfaces on the front fender and fuel tank prior to beginning service. Use care when removing the nacelle so the chrome does not get scratched.

IMPORTANT

During disassembly, pay close attention to harness routing and connector orientation. Always route electrical wiring the same way it was removed to avoid damaging wires and connectors.

1. Remove windshield assembly, if equipped.
2. Using a 5 mm allen, remove two fasteners ① at the top of the nacelle.
3. Using a 4 mm allen, remove two fasteners ② securing the console cover to the fuel tank and lift the console back and set on protected fuel tank.

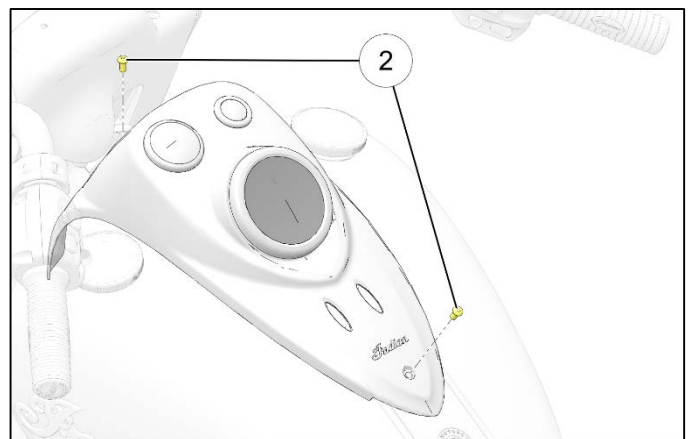
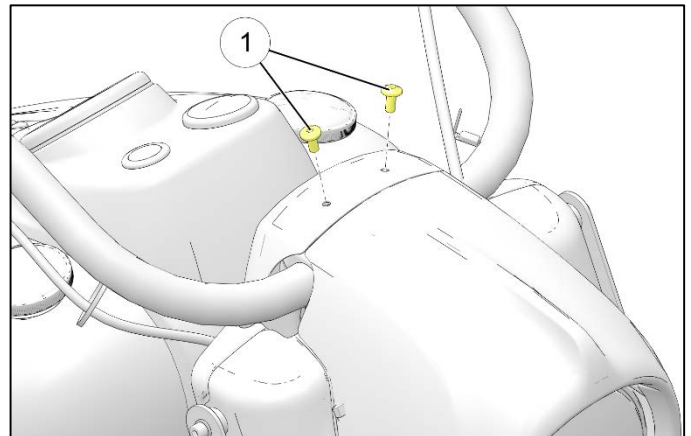

4. Using a 6 mm allen, remove two fasteners ③ per side from the windshield mounting bracket.

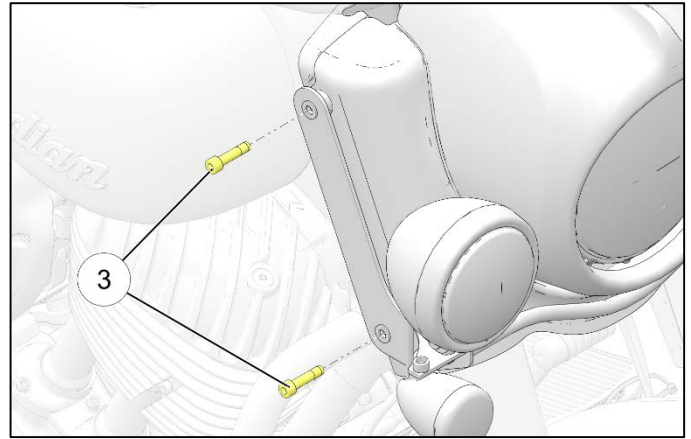

5. Rotate the auxiliary lamp assembly forward and lower out of the way.

6. Pull the front portion of the nacelle out far enough to access the four fasteners ④ securing the headlight bucket to the front nacelle cover. Using a 5 mm allen, remove four fasteners and washers.

7. Pull the headlamp bucket out far enough to disconnect the headlamp connector and remove the bucket assembly ⑤.

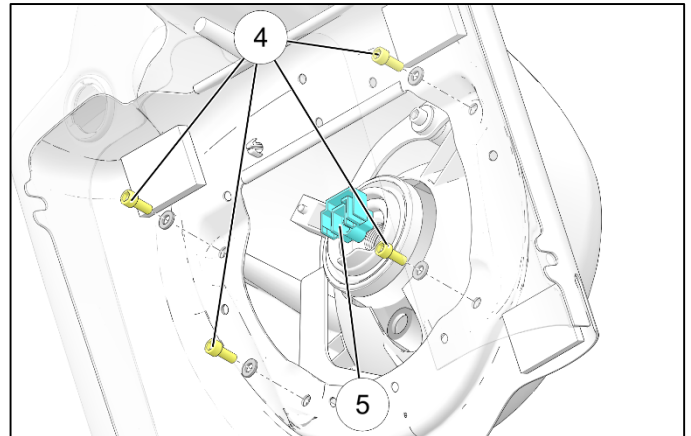

8. Using a 4 mm allen, remove three fasteners ⑥ and washers securing the headlight to the bucket assembly.

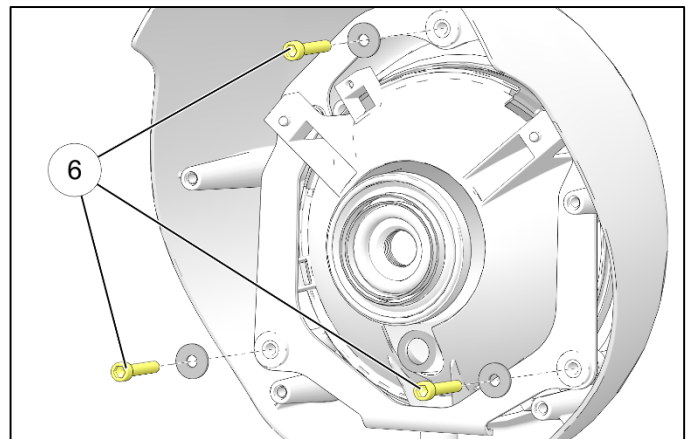

9. Using a Philips head socket adapter, remove fasteners ⑦ and headlight retaining ring ⑧.

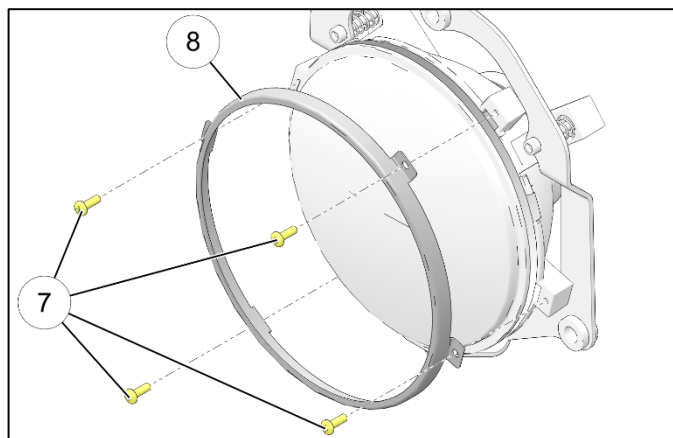

10. Install **NEW** headlight. Install headlight retaining ring ⑧ and fasteners ⑦ to the headlight bracket. Torque fasteners to specification.

TORQUE

Headlight Retaining Ring Fasteners:
12 in-lbs (1 Nm)

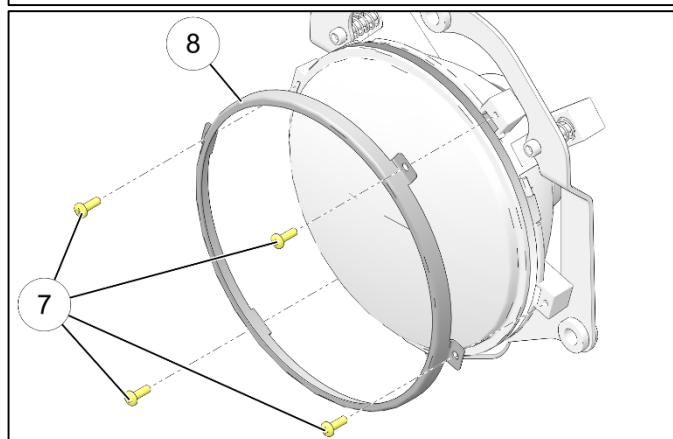

11. Install three fasteners ⑥ and washers securing the headlight to the bucket assembly. Torque fasteners to specification.

TORQUE

Headlight Assembly Fasteners:
12 in-lbs (1 Nm)

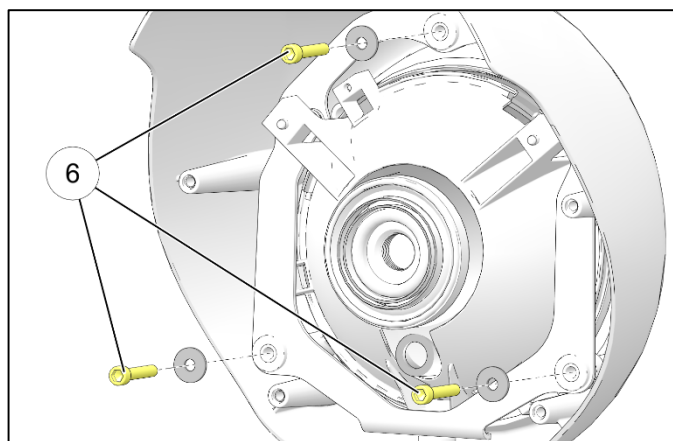

12. Install the four headlamp bucket fasteners ④ and washers. Torque to specification.

TORQUE

Headlamp Bucket Fasteners:
75 in-lbs (8 Nm)

13. Connect the headlamp connector ⑤.

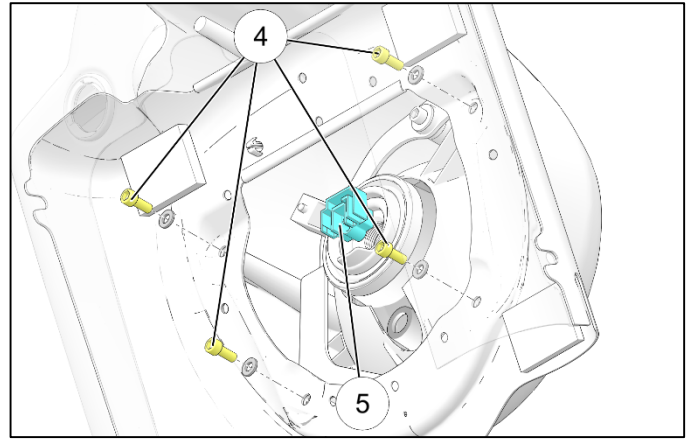

14. Push the front and rear portions of the nacelle together into position around the triple clamp.

15. Install the two fasteners ① located at the top of the nacelle finger tight.

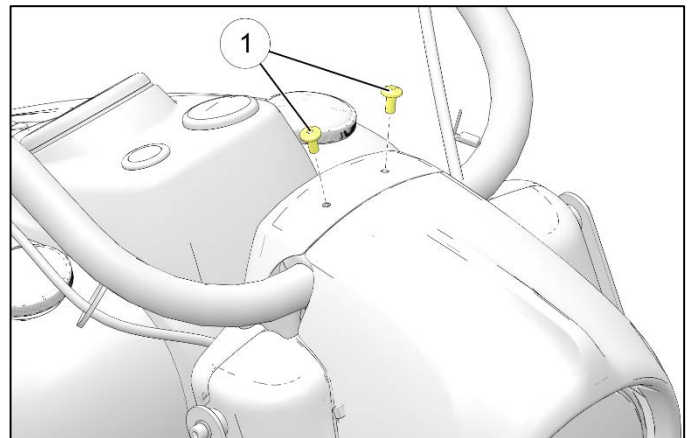

16. Move the light bar / turn signal assembly into position and install four fasteners ③. Torque to specification.

TORQUE

Auxiliary Light Bar Bracket Fasteners:
18 ft-lbs (24 Nm)

NOTE

Verify the rubber grommets securing the auxiliary light / turn signal harness have been slid into place.

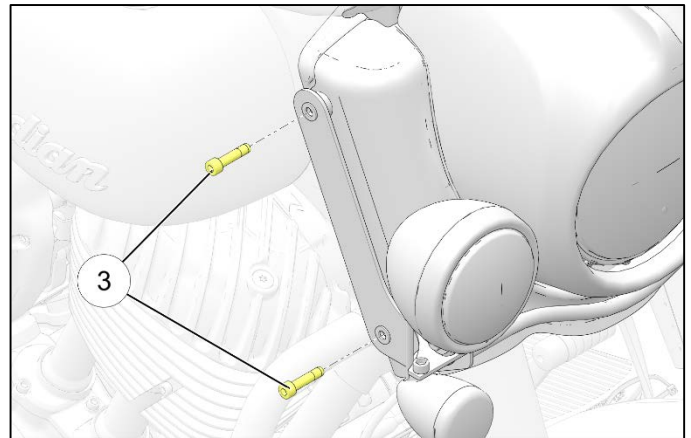

17. Torque the upper nacelle fasteners ① to specification.

TORQUE

Upper Nacelle Fasteners:
36 in-lbs (4 Nm)

18. Move the console cover into place and torque fasteners ② to specification.

TORQUE
 Console Cover Fasteners:
84 in-lbs (10 Nm)

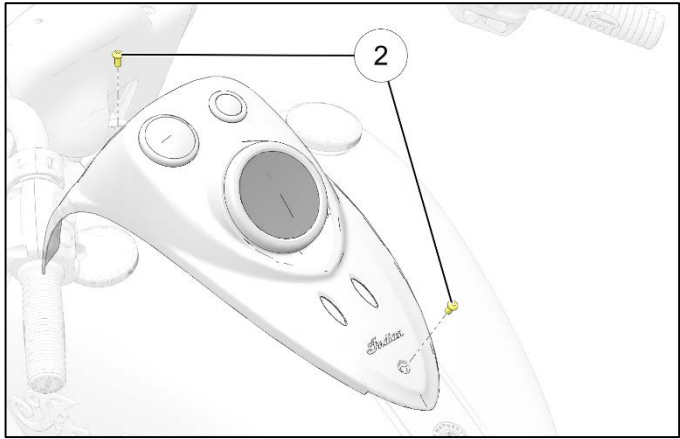

19. Reference the online Service Manual for **HEADLIGHT AIM INSPECTION** and **HEADLIGHT AIM ADJUSTMENT**

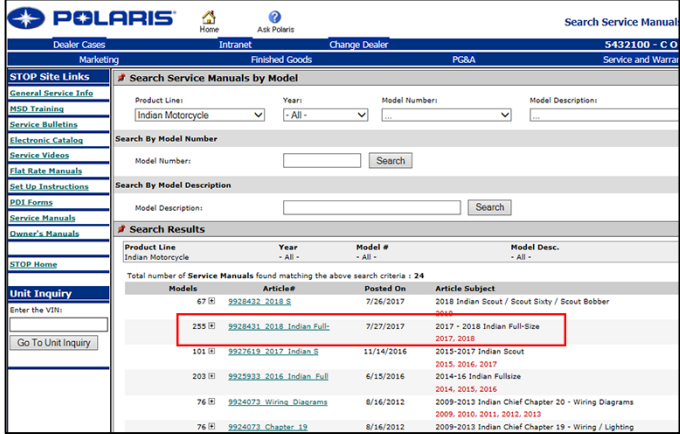

20. Install windshield assembly, if equipped.

21. File a warranty claim for I-17-03-B or C and Install a completed Service Bulletin Completion Decal (7170107).

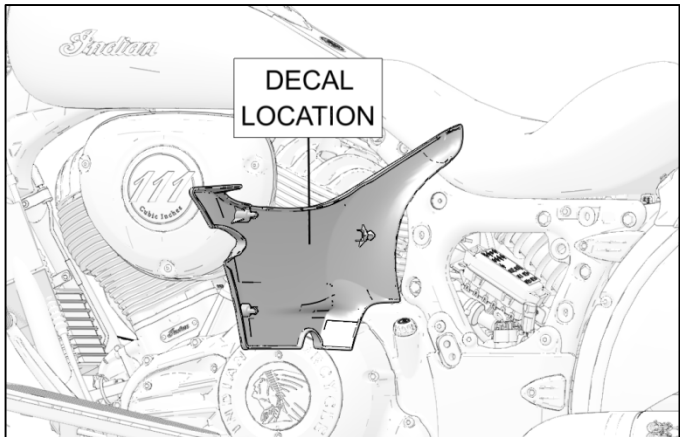

Chieftain / Chieftain Classic / Chieftain Dark Horse / Chieftain Limited / Chieftain Elite Models:

22. Using a 4 mm allen, remove two fasteners ① from headlight bezel ②.

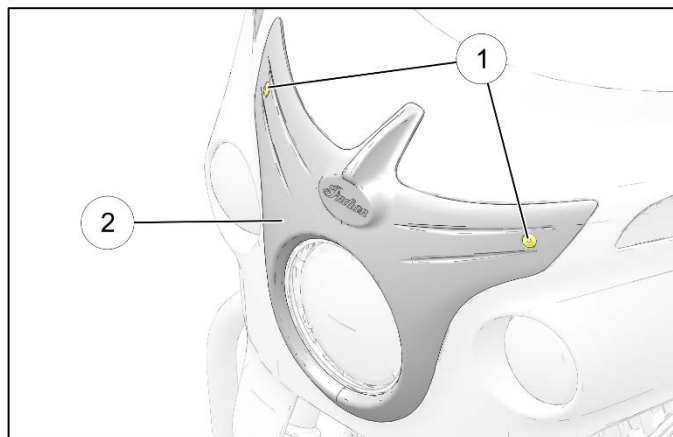

23. Pull out on the top of the bezel to release it from the body. Tilt the bezel out and remove.

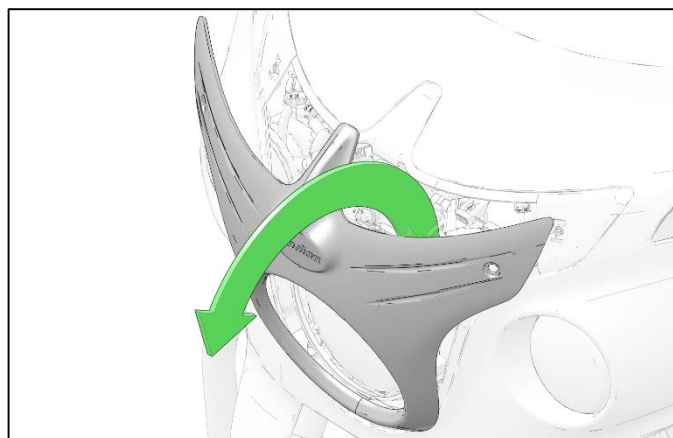

24. Using a Philips head socket adapter, remove fasteners ③ and headlight retaining ring ④.

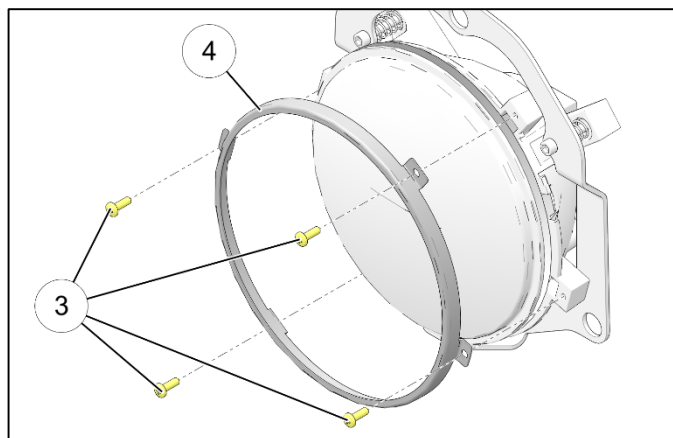

25. Unplug the headlight electrical connection and remove from the headlight bracket .

26. Plug in electrical connector to **NEW** headlight lens.

27. Install headlight retaining ring ④ and fasteners ③ to the headlight bracket.
Torque fasteners to specification.

TORQUE

Headlight Retaining Ring Fasteners:
12 in-lbs (1 Nm)

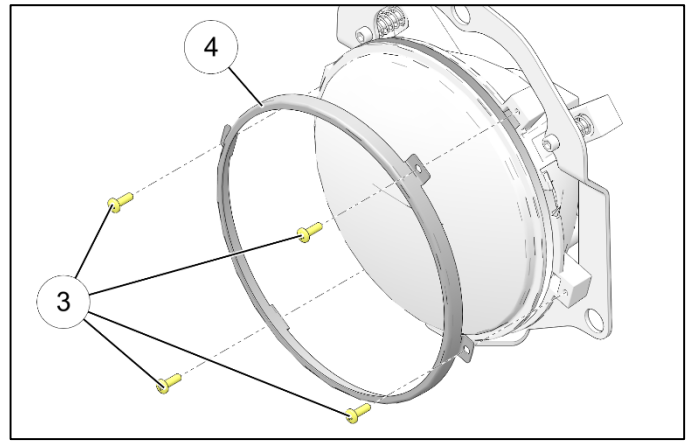

28. Reference the online Service Manual for **HEADLIGHT AIM INSPECTION** and **HEADLIGHT AIM ADJUSTMENT**.

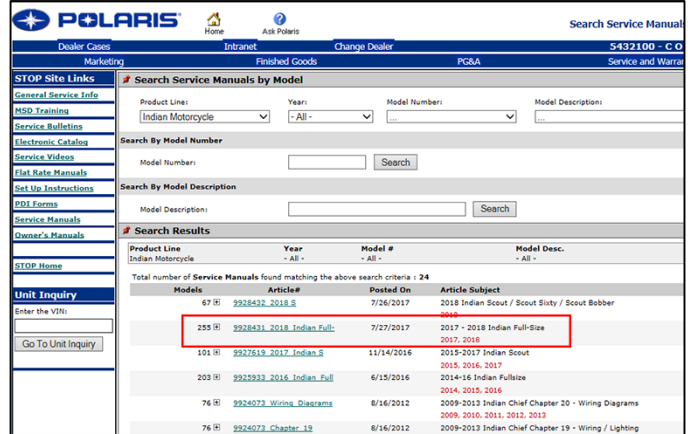

29. Install headlight bezel ② and retain with two fasteners ①. Torque to specification.

TORQUE

Bezel Fasteners:
36 in-lbs (4 Nm)

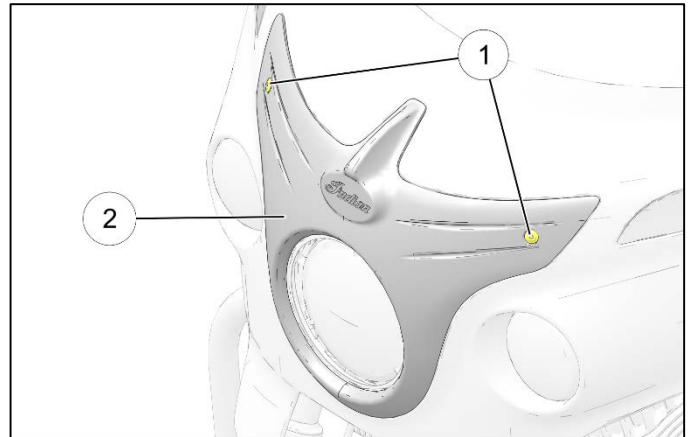

30. File a warranty claim for I-17-03-B or C and Install a completed Service Bulletin Completion Decal (7170107).

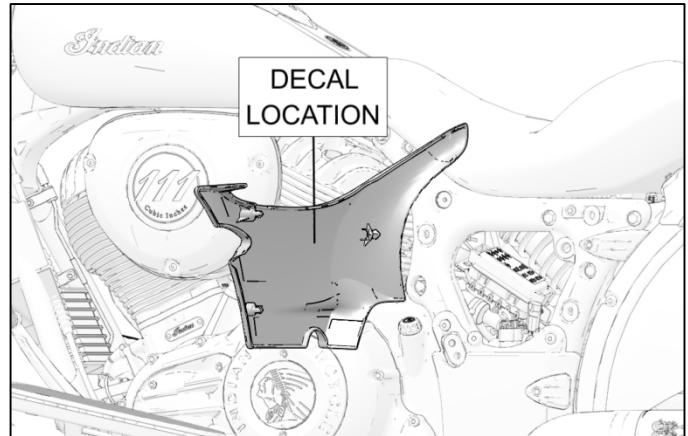



Indian Motorcycle Company
P.O. Box 47700
Medina, MN 55340-9960

IMPORTANT SAFETY RECALL This notice applies to your vehicle

Recall Campaign: 17V682
Subject: 2017-18 Indian Motorcycles (111 c.i.)
Headlight Lens Inspection / Replacement
PLEASE READ IMMEDIATELY

VIN I-17-03

FIRST NAME LAST NAME
ADDRESS
CITY, ST ZIP

Dear Indian Motorcycle Owner:

Indian Motorcycle has determined that motorcycles may have been manufactured with a headlight that does not comply with the Federal Motor Vehicle Safety Standards. Our records indicate that you have purchased a motorcycle that may be affected.

The reason for this notice:

Motorcycles equipped with halogen headlights may have been manufactured using a non-compliant headlight during final assembly. Motorcycles, distributed for sale in North America, may be equipped with an E4 (European) headlight assembly which do not comply with the applicable Federal Motor Vehicle Safety Standards. The E4 headlight has different photometric and marking requirements which must be inspected and, if necessary, replaced with the FMVSS compliant headlight.

What you should do:

Contact your Indian Motorcycle dealer to schedule an inspection; or if you prefer, inspect the headlight on your motorcycle for the markings indicated below.

1. Look at the center headlight from the front of the motorcycle. In the 4 o'clock position, the letters "SAE" must be visible.

- If you have the correct headlight, **no further action is required.**
- If you have an incorrect headlight, contact your authorized Indian Motorcycle dealer to schedule an appointment to have the bulletin repair performed. Do not attempt repairs yourself. Repairs must be done only by an authorized Indian Motorcycle dealer.

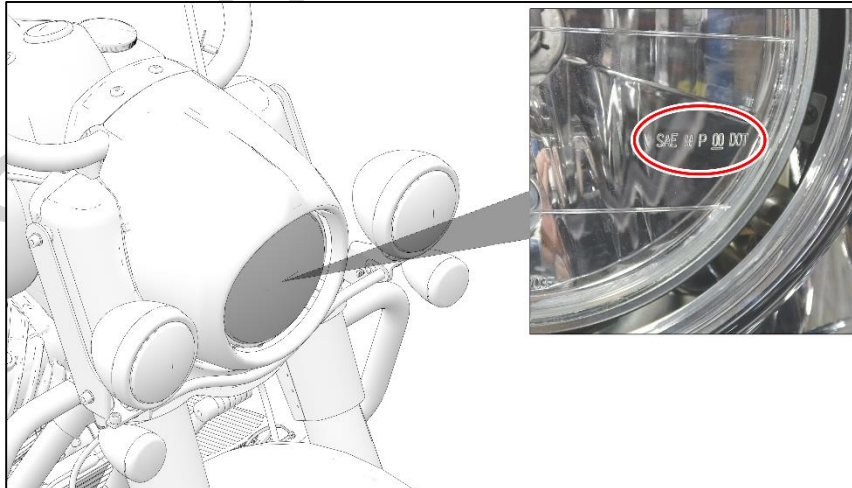

What Indian Motorcycle and your dealer will do:

Indian Motorcycle has issued a Safety *Bulletin* to all Indian Motorcycle dealers, with instructions required to inspect and replace the headlight assembly, as needed. Repairs will be made by any authorized Indian Motorcycle dealer at no cost to you. The actual inspection / installation should take less than one hour to perform; however, it may take longer due to service scheduling requirements.

If you have questions or if you need more information:

While your Indian Motorcycle dealer is in the best position to answer your questions, if you have any questions that your dealer cannot address, if you are having difficulty obtaining the repair outlined in this letter, or if you need assistance finding an Indian Motorcycle dealer, please visit the web site at <http://www.indianmotorcycle.com> or contact our Indian Motorcycle Consumer Service Department by calling 1-877-204-3697.

This notice was mailed to you according to our most current registration information. If you no longer own your Indian motorcycle, please contact your local Indian Motorcycle dealer to have the ownership information changed. The Indian Motorcycle Consumer Service Department cannot change ownership information without identification. Federal law requires that any vehicle lessor receiving this notice must forward a copy of this notice to the lessee within 10 days.

Please accept our apologies for any inconvenience this may cause you. Your safety and continued satisfaction with your Indian Motorcycle is our primary concern. Thank you for your prompt attention to this matter.

Sincerely,
Indian Motorcycle Company

U.S. Consumer Letter