

I. WORK PROCEDURE

1. PRECAUTION

a. [Info](#)

2. PRECAUTION (w/Navigation System)

a. After the power switch is turned off, the display and navigation module display (HDD navigation system) records various types of memory and settings. As a result, after turning the power switch off, make sure to wait at least 60 seconds before disconnecting the cable from the negative (-) battery terminal.

3. ALIGN THE FRONT WHEELS FACING STRAIGHT AHEAD

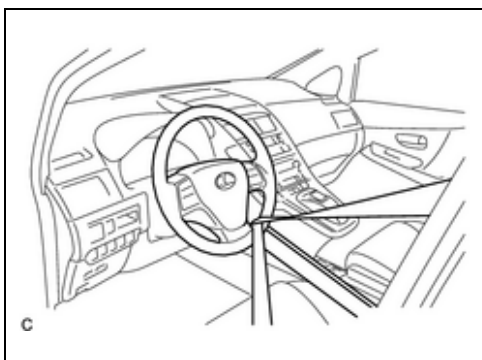

4. SECURE STEERING WHEEL

a. Secure the steering wheel with the seat belt in order to prevent rotation

5. REMOVE LUGGAGE COMPARTMENT FLOOR MAT

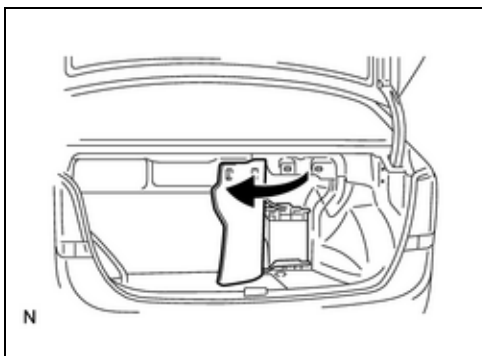

6. DISCONNECT CABLE FORM NEGATIVE BATTERY TERMINAL

a. Open the front luggage compartment trim cover and disconnect the cable from the negative (-) battery terminal.



Failure to comply with the following glove inspection procedures could result in serious bodily injury or death as a result from high voltage electrocution.



- b. Remove the leather outer protective glove (left and right) to expose the rubber High Voltage Service Gloves.
- c. Check the Date of Test stamped on the gloves. This indicates the date of the gloves most recent **Certified electrical inspection**. If the date on the gloves is more than 6 months ago, do not use these gloves. They will either need to be replaced or sent to a Certified Testing Facility for recertification to comply with [OSHA standard 1910.137](#) using the procedure defined in [ASTM F496](#). An internet search for [High Voltage Glove Testing](#) should assist in finding a company to recertify your gloves. For replacement gloves, contact Bosch/OTC at 1-800-933-8335:

Insulated Glove Set, Size M	01413-00072
Insulated Glove Set, Size L	01413-00073
Insulated Glove Set, Size XL	01413-00074

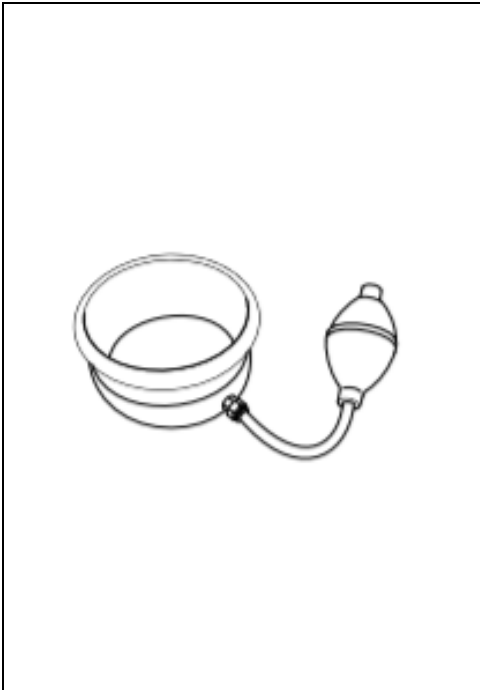

- d. Before each daily use and immediately after any incident that may have caused damage, the gloves must be physically inspected. Using the Glove Inflator found in drawer #2 of the TOYOTA HEV WORKSTATION, inflate each glove and inspect for:
- Air leaks
 - Holes, tears, punctures or cuts
 - Ozone cutting or ozone checking
 - Embedded foreign objects, texture changes, including swelling, softening, hardening, or becoming sticky or inelastic
 - Any other defect that damages the insulating properties.

Gloves with any of the above defects shall be removed from service or returned for testing.

- e. Reinstall the outer protective leather covers (gloves) over the rubber High Voltage glove to prevent damage.

	Failure to comply with the glove inspection procedures could result in serious bodily injury as a result from high voltage electrocution.
--	---

	Electrical protective equipment shall be maintained in a safe, reliable condition. These gloves should be stored to protect them from light, temperature extremes, excessive humidity, ozone, and other damaging substances and conditions. If needed, the gloves can be cleaned as needed to remove foreign substances.
--	--



Rubber insulating gloves should always be used with the outer leather protector gloves in place. If the rubber insulator gloves are used without the protective leather gloves, the rubber insulative gloves need to be retested.

CAUTION:

This vehicle has a hybrid control system that operates at voltages of up to 650 V. Be sure to follow the instructions in this manual to handle the system correctly. Failure to do so may result in serious injury or electrocution.

- (a) Technicians must undergo special training to be able to service and inspect the high-voltage system.
- (b) All high-voltage wire harnesses and connectors are colored orange. The HV battery and other high-voltage components have "High Voltage" caution labels. Do not carelessly touch these wires or components.
- (c) When there is a problem with the wire harness or connector of a high-voltage circuit, repairs to the harness or connector should not be attempted. Replace damaged or malfunctioning high voltage cables or connectors.
- (d) Before inspecting or servicing the high-voltage system, be sure to follow all safety measures, such as wearing insulated gloves and removing the service plug to prevent electrocution. Carry the removed service plug in your pocket to prevent other technicians from accidentally reconnecting it while you are servicing the vehicle.

NOTICE:

After removing the service plug grip, do not turn the power switch on (READY), unless instructed by the repair manual because this may cause a malfunction.

- (e) After removing the service plug grip, wait 10 minutes before touching any of the high-voltage connectors and terminals.

HINT:

Waiting for at least 10 minutes is required to discharge the high-voltage capacitor inside the inverter with converter assembly.

- (f) Before using insulated gloves, be sure to check them for cracks, tears and other types of damage.
- (g) When servicing the vehicle, do not carry metal objects like mechanical pencils or rulers that can be dropped accidentally and cause a short circuit.
- (h) Before touching a bare high-voltage terminal, wear insulated gloves and use a tester to make sure that the terminal voltage is 0 V.

- (i) After disconnecting or exposing a high-voltage connector or terminal, insulate it immediately using insulating tape.

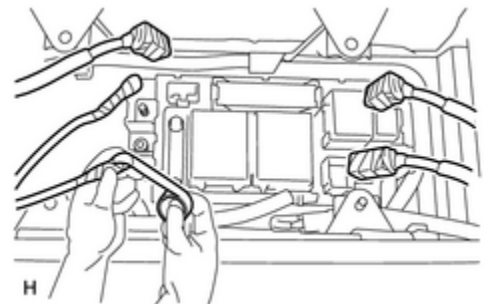

- (j) Bolts and nuts for high-voltage terminals should be tightened firmly to the specified torque. Both insufficient and excessive torque can cause failure.
- (k) Use the "CAUTION: HIGH VOLTAGE DO NOT TOUCH" sign to notify other technicians that the high-voltage system is being inspected and/or repaired.
- (l) After servicing the high-voltage system and before reinstalling the service plug, check again that you have not left a part or tool inside, that the high-voltage terminals are firmly tightened, and that the connectors are correctly connected.

- (m) When performing work involving high-voltage wires, use either a tool wrapped with vinyl insulation tape or an insulated tool.
- (n) When installing hybrid control system components such as the HV battery, make sure that the polarity of all connections is correct.

CAUTION:

- Do not touch any bare cables that may have high-voltage. If a cable must be touched or if accidental contact is possible, wear insulated gloves and insulate the cable using insulating tape.
- Visually check the HV battery and the immediate area for any electrolyte leakage. Do not touch any leaked liquid because it could be organic electrolyte that contains carbonic acid esters.
- The electrolyte is flammable. Keep all ignition sources such as open flame and hot objects away from the electrolyte.
- Electrolyte leaks may cause acute poisoning if a high concentration of the vapor from the organic solvent is inhaled. In case of inhalation, move the affected person to a place with ample fresh air and let them lie quietly. Seek medical care.
- In case of skin contact with the electrolyte, wash the area thoroughly with soap and plenty of water, and seek medical care. Immediately remove any contaminated clothing. Prolonged contact with the electrolyte may cause skin irritation.
- If the electrolyte comes in contact with your eyes, call out loudly for help. Do not rub your eyes. Immediately flush them with a large amount of water for at least 15 minutes and seek medical care.
- If electrolyte is swallowed, seek medical care immediately. Do not induce vomiting, unless instructed by the doctor.
- Wear insulated or rubber gloves, goggles, and safety shoes.
- Check the HV battery and immediate area for any electrolyte leakage.
- Do not touch any bare cables that could be high voltage cables. If a cable must be touched or if accidental contact is possible, follow the following instructions: 1) wear insulated gloves and goggles, 2) measure the voltage between the cable and body ground using an electrical tester, and 3) insulate the cable using insulating tape.
- Do not touch any bare cables that may have high-voltage. If a cable must be touched or if accidental contact is possible, wear insulated gloves and insulate the cable using insulating tape.
- Do not touch any leaked liquid because it could be the organic electrolyte that contains carbonic acid esters. If contact is unavoidable, wipe the fluid off using a cloth while wearing rubber gloves, goggles and an organic solvent mask. Do not leave electrolyte-contaminated cloths unattended. Place contaminated cloths in an appropriate airtight container and dispose of them according to local regulations.
- Accidents such as electric shock may result if the HV battery or a hybrid vehicle supply stack sub-assembly is disposed of improperly or abandoned. Therefore, make sure to return all HV batteries or hybrid vehicle supply stack assemblies through an authorized collection agent.
- To reduce the risk of fire, the HV battery or hybrid vehicle supply stack assembly must not be stored in an area where it will be exposed to fire or high temperatures.

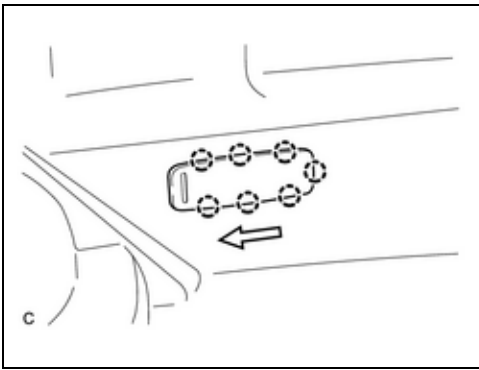

- 7. REMOVE BATTERY SERVICE HOLE COVER**
 a. Slide the latch and remove the service hole cover



You are about to remove the High Voltage Service Plug. There is a potential for electrical shock and arc flash. Make sure to wear safety glasses and the properly inspected High Voltage Service Gloves with the leather outer covers.

8. REMOVE SERVICE PLUG GRIP

- a. Wear insulating gloves and remove the service plug grip after sliding up the lever of the service plug grip as shown in the illustration

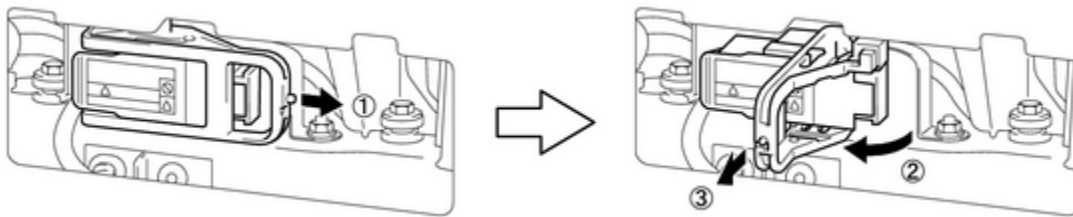

After removing the service plug grip, do not touch the high voltage connectors or terminals for 10 minutes

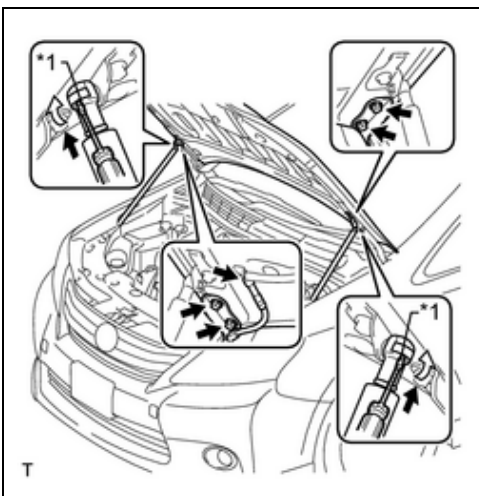

9. REMOVE HOOD SUB-ASSEMBLY

- a. Disconnect the washer hose
 b. Using a screwdriver, remove the 2 stop rings along the groove
 c. Release the 2 ball joints and separate the 2 hood support assemblies from the hood
 d. Remove the 4 bolts and hood assembly

*1	Protective Tape
----	-----------------

10. REMOVE THE FOLLOWING COMPONENTS

- a. Front Wheels
 b. Rear Engine Cover LH & RH
 c. Engine Under Cover
 d. No.1 Engine Under Cover
 e. No.2 Engine Under Cover
 f. No.3 Engine Under Cover

11. DRAIN INVERTER COOLANT

- a. [Info](#)



DO NOT DRAIN ENGINE COOLANT

12. DRAIN HYBRID TRANSAXLE FLUID

- a. [Info](#)

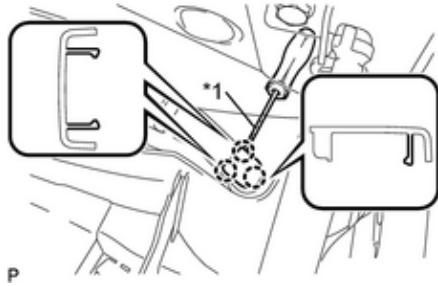

13. REMOVE FRONT WIPER ARM HEAD CAP

- a. Using a screwdriver, disengage the 3 claws and remove the front wiper arm head cap

*1 Protective Tape

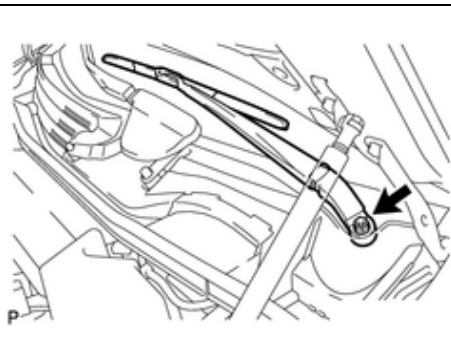

14. REMOVE FRONT WIPER ARM AND BLADE ASSEMBLY LH

- a. Remove the nut and the front wiper arm and blade assembly LH

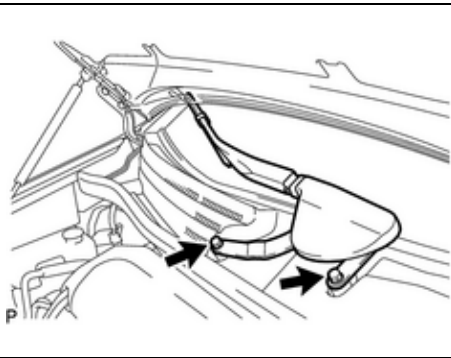

15. REMOVE FRONT WIPER ARM AND BLADE ASSEMBLY RH

- a. Remove the 2 nuts and the front wiper arm and blade assembly RH

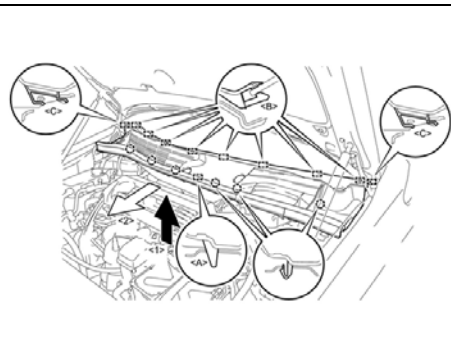

16. REMOVE COWL TOP VENTILATOR LOUVER SUB-ASSEMBLY

- a. Remove the 2 clips
b. Disengage the 6 claws and guide <A> as shown in the illustration
c. Disengage the 8 guides and 2 guides <C>, and pull out the cowl top ventilator louver sub-assembly as shown in the illustration

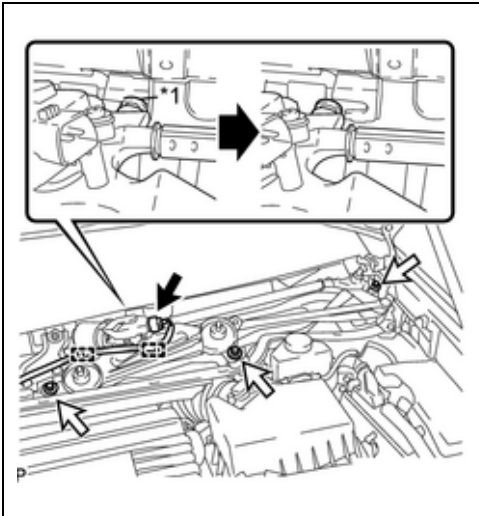

17. REMOVE WINDSHIELD WIPER MOTOR AND LINK ASSEMBLY

- a. Disconnect the connector
- b. Disengage the 2 clamps
- c. Remove the 3 bolts
- d. Disengage the grommet and remove the windshield wiper motor and link assembly as shown in the illustration

*1	Grommet
----	---------

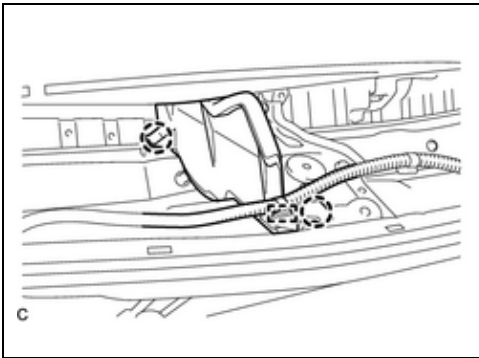

18. REMOVE WATER GUARD PLATE RH

- a. Disengage the clamp and separate the wire harness
- b. Disengage the 2 claws to remove the water guard plate RH

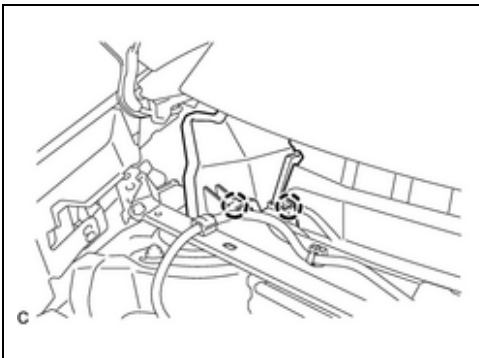

19. REMOVE NO. 2 HEATER AIR DUCT SPLASH SHIELD SEAL

- a. Disengage the 2 claws to remove the No. 2 heater air duct splash shield seal

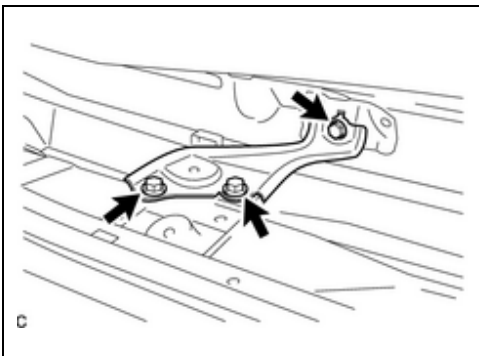

20. REMOVE COWL BODY MOUNTING REINFORCEMENT RH

- a. Remove the 3 bolts and cowl body mounting reinforcement RH

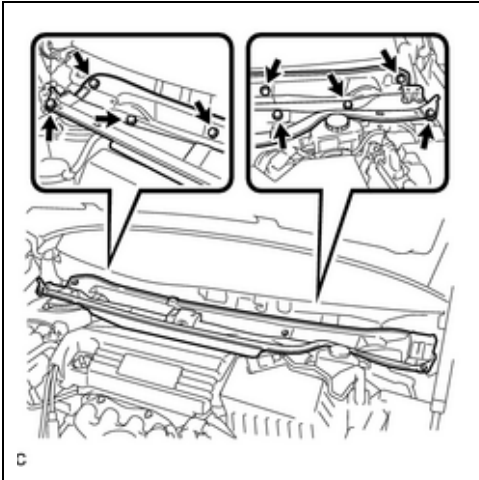

21. REMOVE OUTER COWL TOP PANEL SUB-ASSEMBLY

- a. Disengage the 2 clamps of the wire harness
- b. Remove the 9 bolts and outer cowl top panel sub-assembly

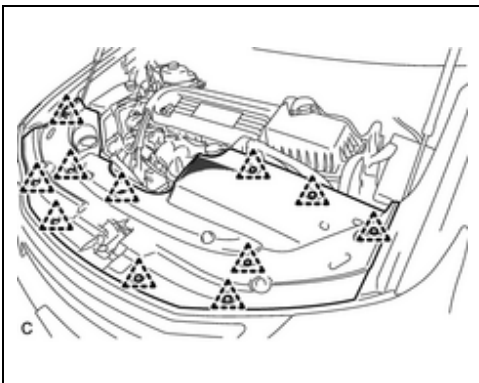

22. REMOVE COOL AIR INTAKE DUCT SEAL

- a. Remove the 11 clips and cool air intake duct seal

23. REMOVE NO. 1 ENGINE COVER SUB-ASSEMBLY

- a. Remove the 3 clips and No. 1 engine cover sub-assembly

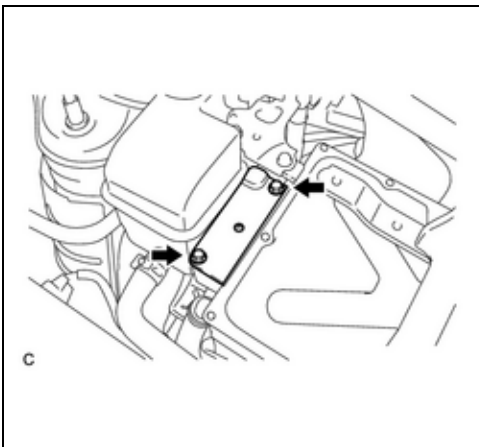

24. REMOVE CONNECTOR COVER ASSEMBLY

- a. Remove the 2 bolts and connector cover assembly



- Do not touch the high voltage connectors and terminals for 10 minutes after the service plug grip is removed.
- Wear insulated gloves

NOTE: Make sure to pull the cover straight up as a connector is connected to the bottom of the cover

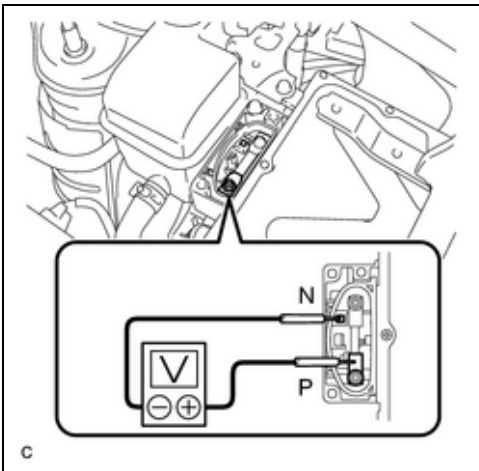

25. CHECK TERMINAL VOLTAGE

- a. Using a voltmeter, measure the voltage between the terminals of the 2 phase connectors (N-P)

STANDARD VOLTAGE: 0 V



- Do not allow any foreign objects or water to enter the inverter with converter assembly.
- Wear insulated gloves

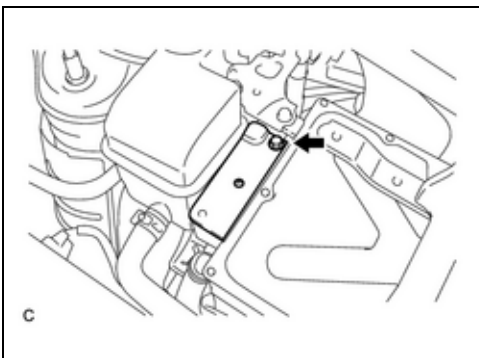

26. TEMPORARILY INSTALL CONNECTOR COVER ASSEMBLY

- a. Temporarily install the connector cover with the bolt to prevent any foreign objects or water from entering the inverter assembly

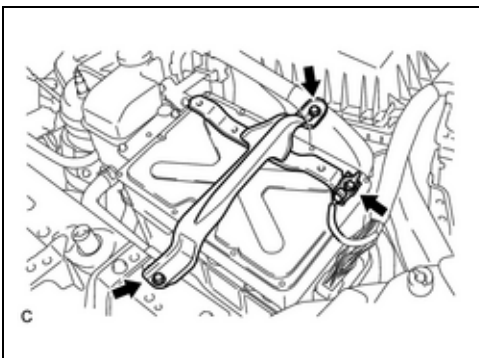

27. REMOVE NO.5 INVERTER BRACKET

- a. Remove the 2 bolts and disconnect the earth wire

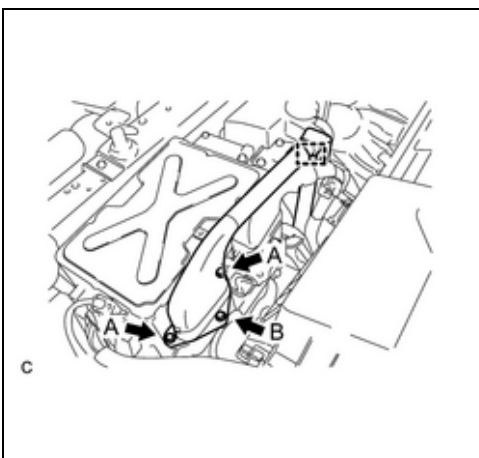

28. SEPARATE GENERATOR CABLE

- a. Remove the 2 bolts (A)
- b. While loosening the bolt (B), disconnect the motor cable



- Removing bolts (A) and (B) in the wrong order will cause the cable or the inverter to break.
- Insulate the removed terminals with insulating tape
- Cover the hole where the cable was connected with tape or equivalent (non-residue type) to prevent entry of foreign matter.
- Wear insulated gloves

- c. Disconnect the wire harness clamp

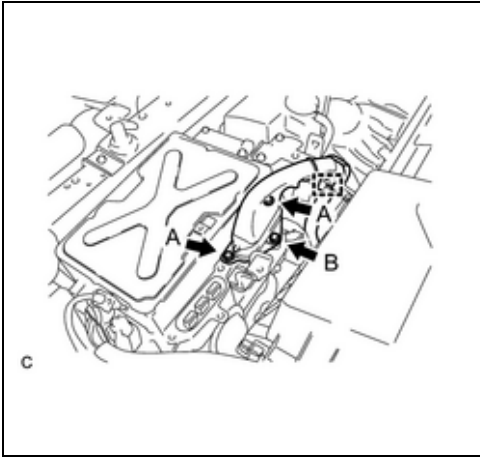

29. SEPARATE MOTOR CABLE

- a. Remove the 2 bolts (A)
- b. While loosening the bolt (B), disconnect the motor cable



- Removing bolts (A) and (B) in the wrong order will cause the cable or the inverter to break.
- Insulate the removed terminals with insulating tape
- Cover the hole where the cable was connected with tape or equivalent (non-residue type) to prevent entry of foreign matter.
- Wear insulated gloves

- c. Disconnect the wire harness clamp

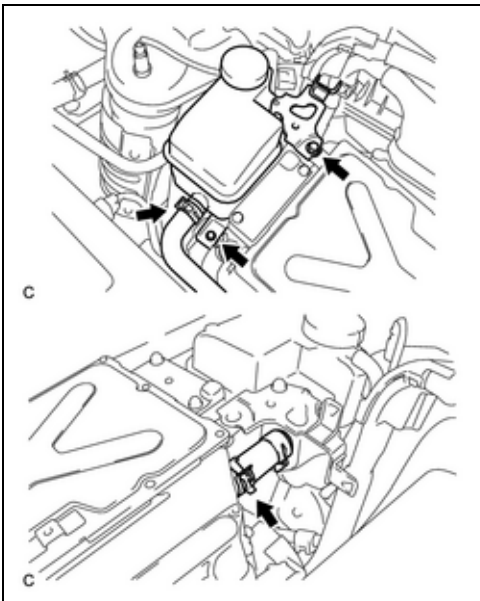

30. REMOVE INVERTER RESERVE TANK ASSEMBLY

- a. Disconnect the water hose from the inverter reserve tank assembly
- b. Remove the 2 bolts and inverter reserve tank assembly
- c. Disconnect the water hose and remove the inverter reserve tank assembly

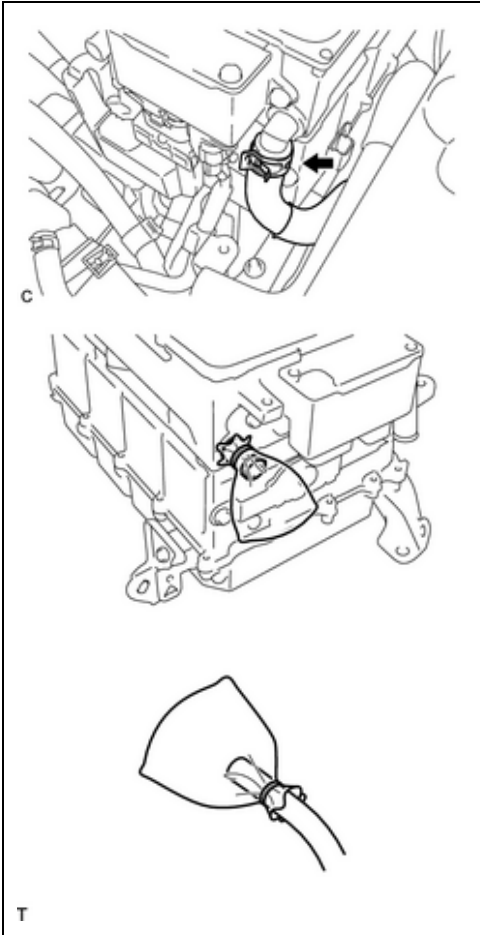

31. DISCONNECT WATER HOSE

a. Remove the clip and water hose

b. Disconnect the coolant hose from the inverter with converter assembly. Put a piece of cloth in the pipe and in the disconnected hose or cover the pipe and hose with plastic bags as shown in the illustration, in order to prevent coolant from spilling near the inverter with converter assembly

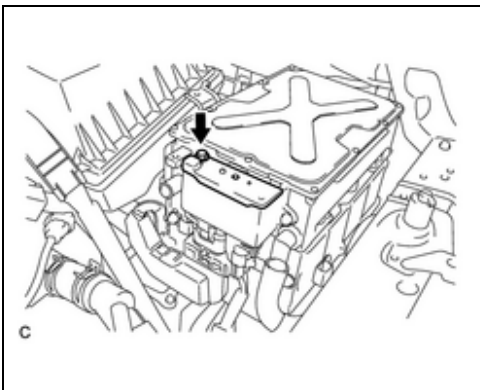

32. REMOVE CONNECTOR COVER ASSEMBLY

a. Remove the 2 bolts and connector cover assembly



- Do not touch the high voltage connectors and terminals for 10 minutes after the service plug grip is removed.
- Wear insulated gloves

NOTE: Make sure to pull the cover straight up as a connector is connected to the bottom of the cover

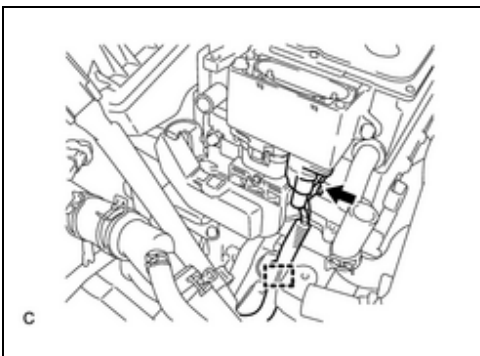

33. SEPARATE AIR CONDITIONING HARNESS ASSEMBLY

a. Disconnect the air conditioning harness assembly

b. Disengage the wire harness clamp



- Do not allow any foreign objects or water to enter the inverter with converter assembly.
- Wear insulated gloves

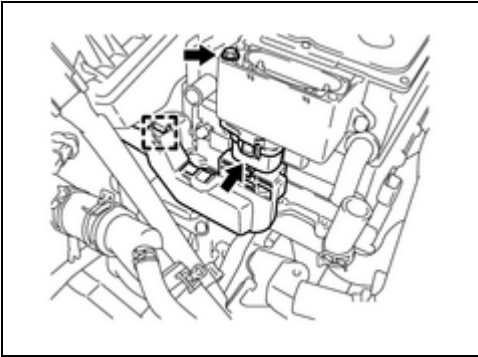

34. SEPARATE FRAME WIRE

- a. Remove the bolt
- b. Disconnect the wire harness clamp and frame wire



- Do not allow any foreign objects or water to enter the inverter with converter assembly.
- Wear insulated gloves

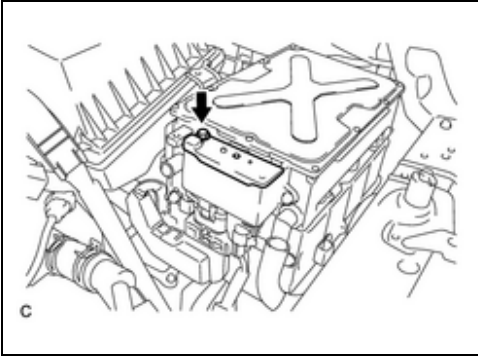

35. TEMPORARILY INSTALL CONNECTOR COVER ASSEMBLY

- a. Temporarily install the connector cover with the bolt to prevent any foreign objects or water from entering the inverter with converter assembly

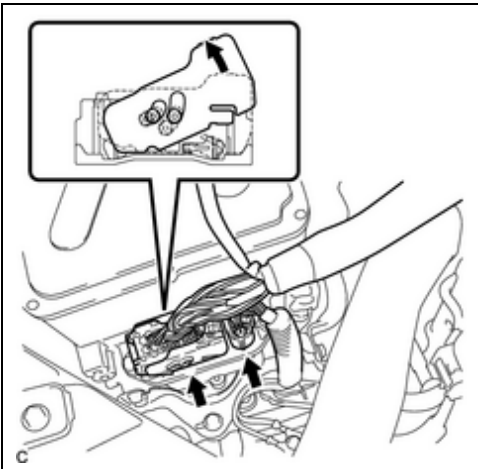

36. DISCONNECT THE LOW VOLTAGE CONNECTOR

- a. Raise the lock lever and disconnect the low voltage connector
- b. Disconnect the low voltage connector from the inverter assembly



- Do not allow any foreign objects or water to enter the inverter with converter assembly.
- Wear insulated gloves

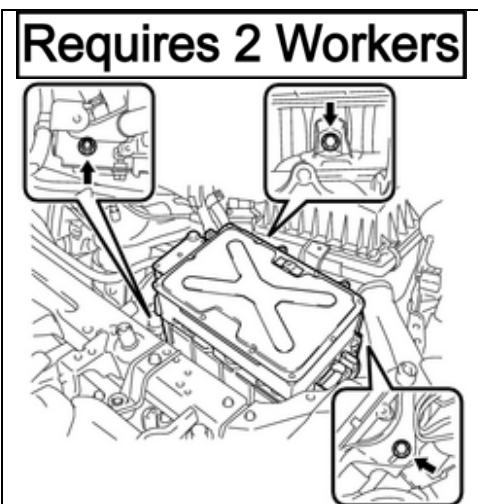

37. REMOVE INVERTER WITH CONVERTER ASSEMBLY

- a. Remove the 2 bolts, nut and inverter assembly



- Do not hold the inverter by the connectors
- Do not touch the terminals of the disconnected connectors

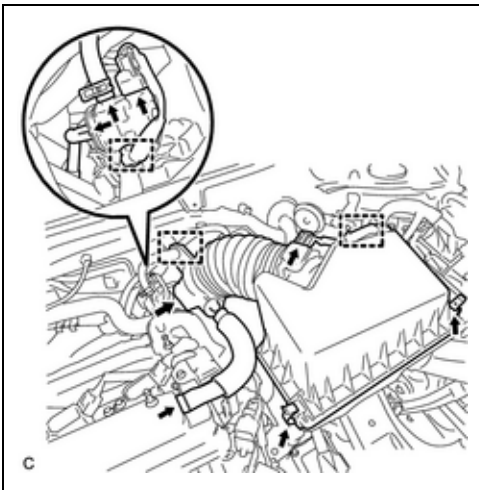

38. REMOVE AIR CLEANER CAP SUB-ASSEMBLY

- a. Disconnect the clamp and air flow meter connector
- b. Disconnect the No. 1 fuel vapor feed hose from the vacuum switching valve assembly and air cleaner hose
- c. Disconnect the No. 2 fuel vapor feed hose from the vacuum switching valve assembly
- d. Disconnect the clamp and vacuum switching valve connector
- e. Disconnect the 2 clamps and hose band, and remove the air cleaner cap sub-assembly
- f. Remove the air cleaner filter element

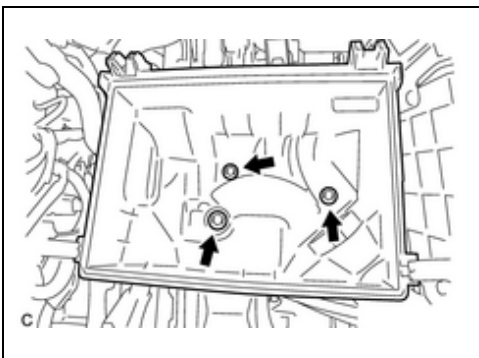

39. REMOVE AIR CLEANER CASE

- a. Remove the 3 bolts and air cleaner case

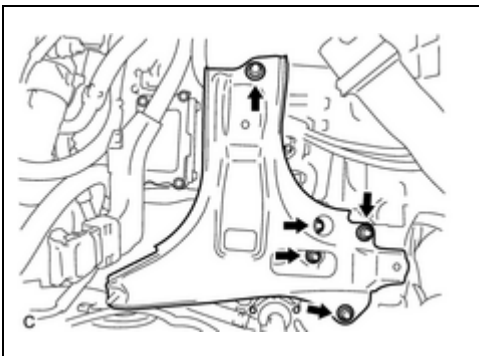

40. REMOVE INVERTER BRACKET ASSEMBLY

- a. Remove the 5 bolts and inverter bracket assembly

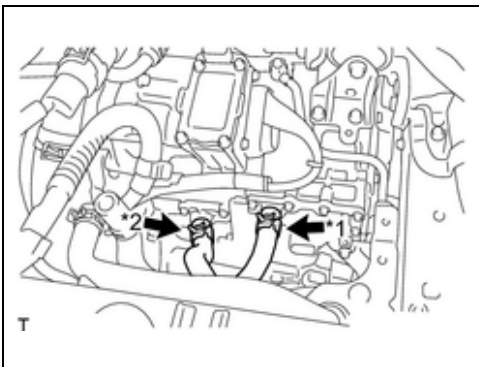

41. DISCONNECT NO.3 AND NO.5 INVERTER COOLING HOSE

- a. Disconnect the No.3 inverter hose from the hybrid transaxle
- b. Disconnect the No.5 inverter cooling hose from the hybrid transaxle

*1	No. 5 Inverter Cooling Hose
*2	No. 3 Inverter Cooling Hose

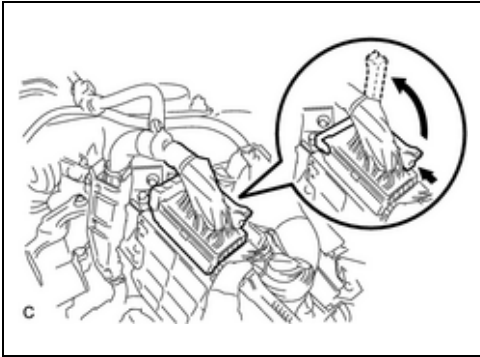

42. DISCONNECT WIRE HARNESS

- a. Pull up the lever and disconnect the connector of the hybrid vehicle control ECU

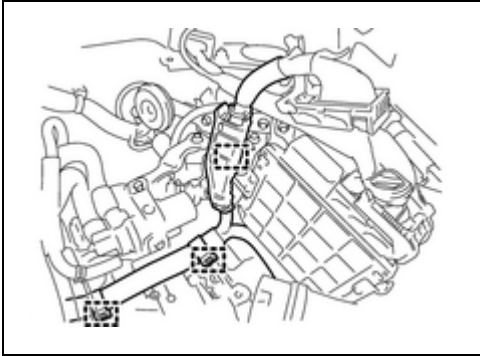

- b. Disconnect the 3 clamps

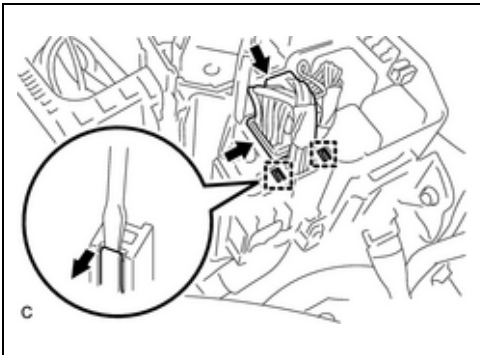

- c. Disconnect the 2 connectors and 2 clamps from the engine room junction block and disconnect the wire harness



- d. Remove the bolt and disconnect the earth wire

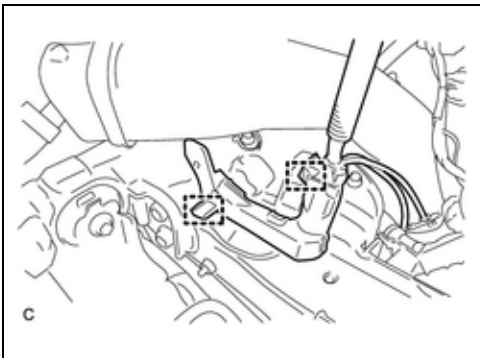

e. Disconnect the 2 clamps

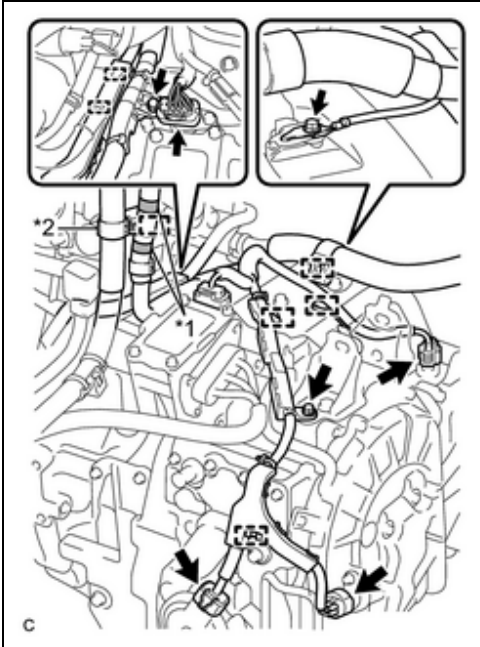

f. Disconnect the 4 connectors, 7 clamps, and 3 bolts

NOTE: When removing clamp A, disengage it from the motor cable

*1	Marking Tape
*2	Clamp A
*3	Motor Cable

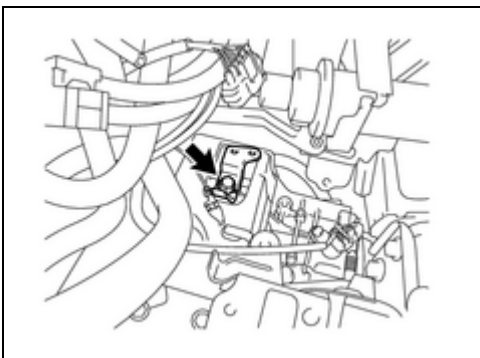

g. Remove the bolt and wire harness bracket

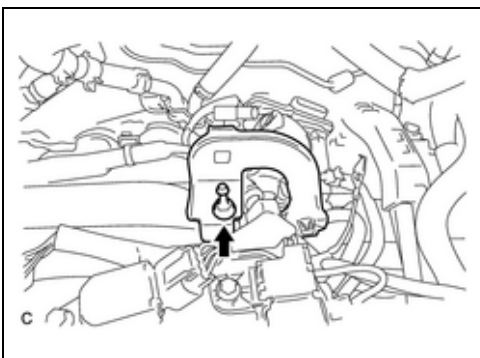

h. Remove the bolt and heater hose bracket

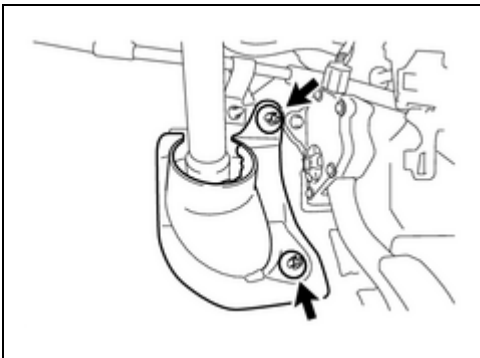

- 43. REMOVE COLUMN HOLE COVER SILENCER SHEET**
- Turn back the floor carpet
 - Remove the 2 clips and column hole cover silencer sheet

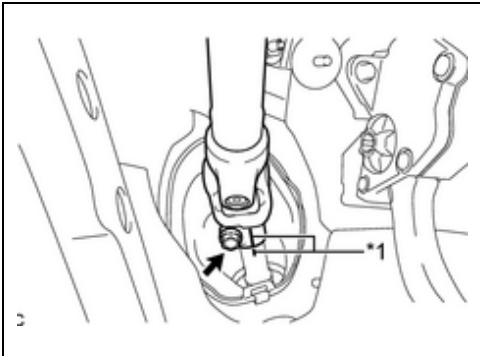

- 44. SEPARATE NO.2 STEERING INTERMEDIATE SHAFT ASSEMBLY**
- Put matchmarks on the No.2 steering intermediate shaft assembly and steering intermediate shaft

*1	Matchmark
----	-----------

- Remove the bolt and separate the No.2 steering intermediate shaft assembly from the intermediate shaft

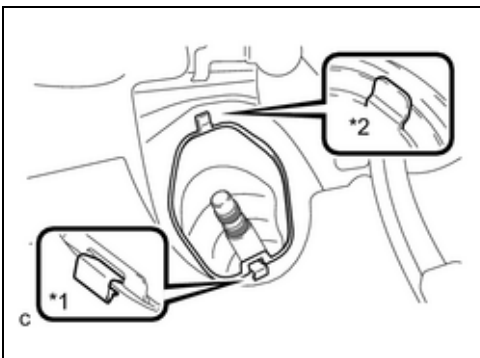

- 45. SEPARATE NO.1 STEERING COLUMN COVER SUB-ASSEMBLY**
- Remove clip A, detach clip B from the body and disconnect the No.1 steering column hole cover sub-assembly

*1	Clip A
*2	Clip B

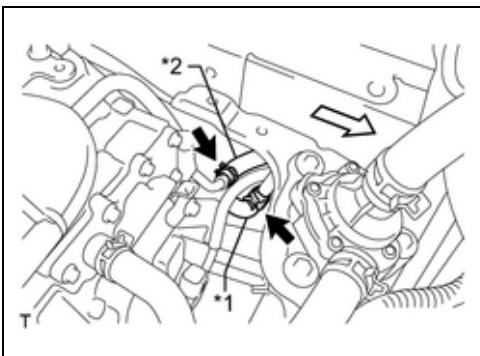

- 46. DISCONNECT NO.1 AND NO.2 MOTOR COOLING HOSE**
- Disconnect 2 clamps and the No.1 and No.2 motor cooling hose

*1	No. 1 Motor Cooling Hose
*2	No. 2 Motor Cooling Hose
➔	Front Side



- **LOCKING AGENT IS APPLIED TO THE ENGINE MOUNTING BRACKET BOLTS, SO A HIGHER EFFORT IS REQUIRED TO LOOSEN THEM. IN ORDER TO LOOSEN THE BOLTS EASILY WITH LESS EFFORT IN THE LATER STEP, LOOSEN THE BOLTS BEFORE THE VEHICLE IS RAISED.**

- a) Put a wooden piece onto a jack, set the jack under the hybrid vehicle transaxle as shown in the illustration, and allow the wooden piece to touch the transaxle.

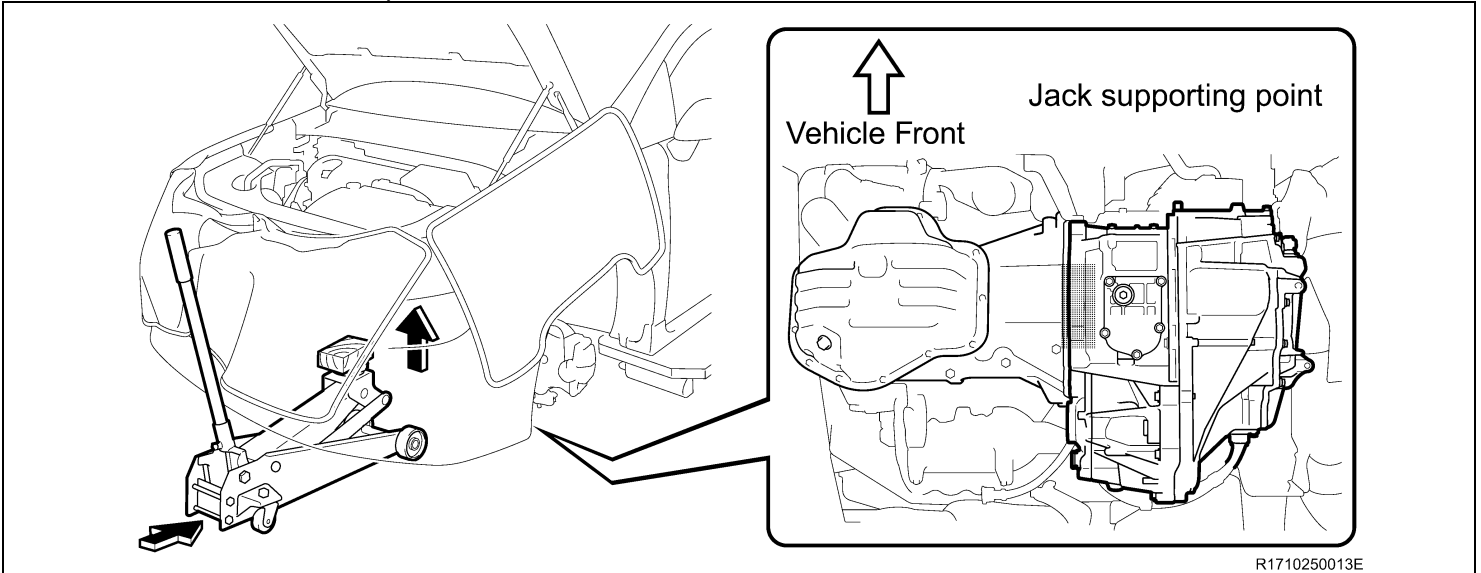

R1710250013E

Remove the bolt

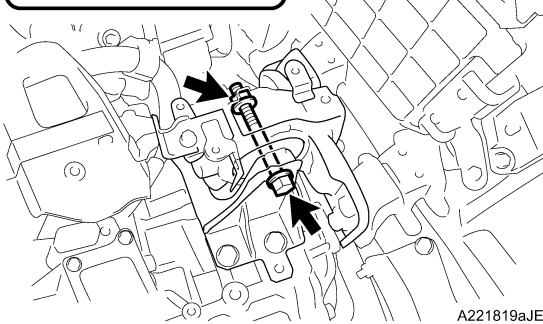

A221819a,JE

- b) Remove the nut.
c) One of the 2 workers raises the vehicle with the jack to reduce the load applied to the through bolt, and the other worker removes the bolt.



- **Ensure that the wire harness, pipes, or cables are not caught by the components.**
- **Remove the through bolt as it will interfere with a tool when the bracket bolts are loosened.**

Temporary tightening after loosening once



R1710250012CJE

- d) Loosen the 4 bracket bolts.
e) Temporarily tighten the 4 bolts uniformly in several steps until the bolt heads seat.

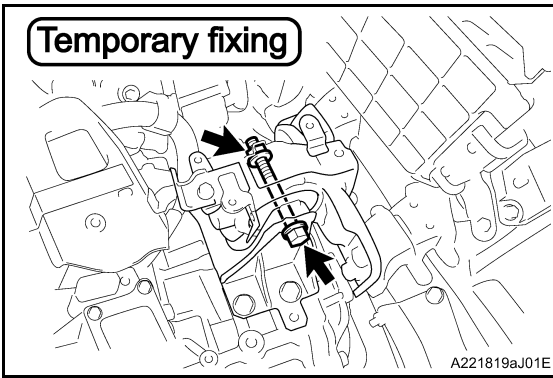

- f) Reinstall the removed through bolt and nut, and temporarily tighten them.
- g) Remove the jack.

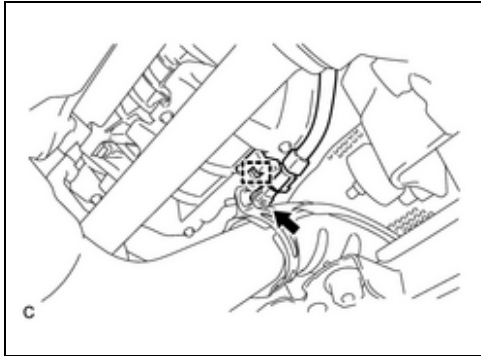

47. REMOVE FRONT EXHAUST PIPE ASSEMBLY

- a. Disconnect the oxygen sensor connector and wire harness clamp

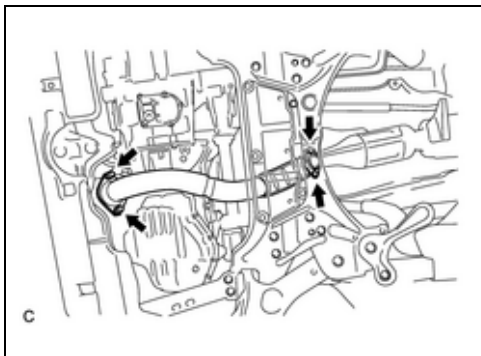

- b. Remove the 4 bolts, 2 compression springs, and front exhaust pipe assembly
- c. Remove the 2 gaskets from the exhaust manifold converter sub-assembly and front exhaust pipe assembly

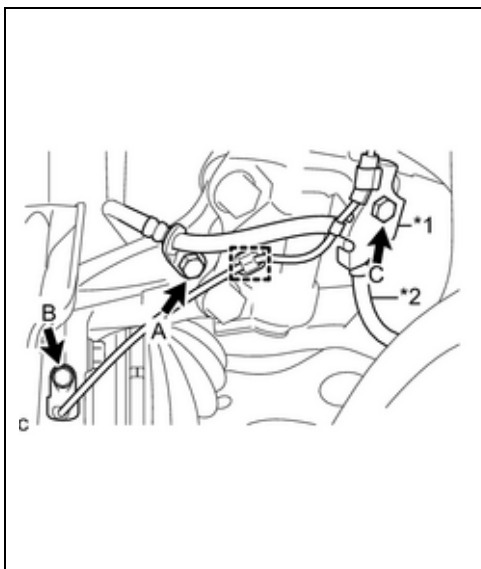

48. SEPARATE FRONT SPEED SENSOR LH AND RH AND FRONT FLEXIBLE HOSE

- a. Remove bolt B, bolt C, and the clamp, and separate the front speed sensor LH and front flexible hose LH from the shock absorber and steering knuckle.
- b. Remove bolt A and separate the flexible hose LH from the steering knuckle.

Use the same procedure for the RH side

*1	Front Speed Sensor
*2	Front Flexible Hose

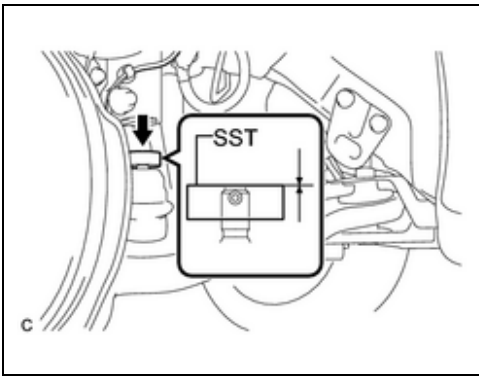

49. SEPARATE TIE ROD END SUB-ASSEMBLY LH AND RH

- a. Remove the cotter pin and nut
- b. Install the SST to the tie rod end

Use the same procedure for the RH side

SST: 09960-20010

NOTE: Make sure the upper ends of the tie rod end and SST are aligned

c. Using SST, separate the tie rod end from the steering knuckle

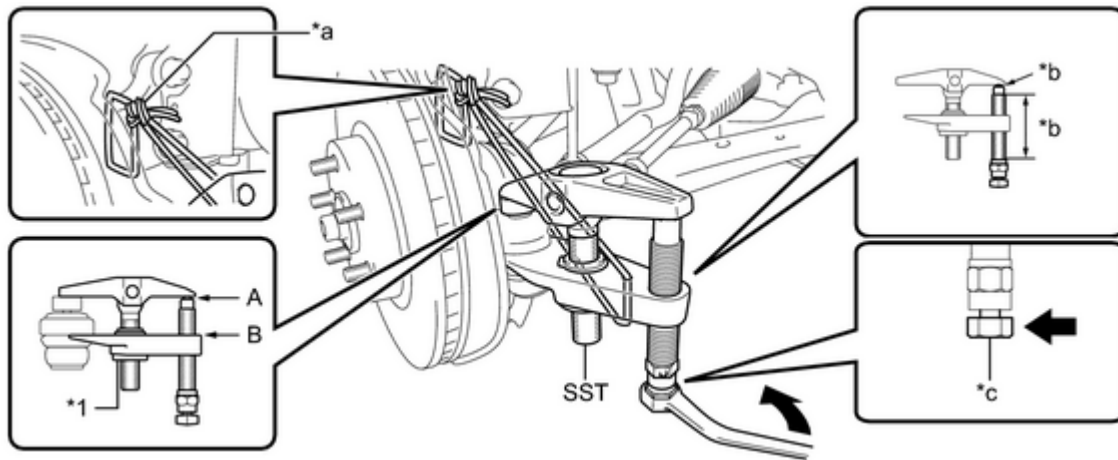

*1	Nut
*a	Tighten the string without leaving any slack.
*c	Place the wrench here.
*b	Grease Application Area

NOTE:

- Apply grease to the bolt threads and the tip of the SST
- Be sure to tighten the string firmly to secure SST to the steering knuckle to prevent SST from falling off.
- Install SST with the center nut so that A and B shown in the illustration are parallel. Otherwise, the dust cover may be damaged
- Be sure to place the wrench on the part indicated in the illustration
- Do not damage the front disc brake dust cover
- Do not damage the ball joint dust cover
- Do not damage the steering knuckle

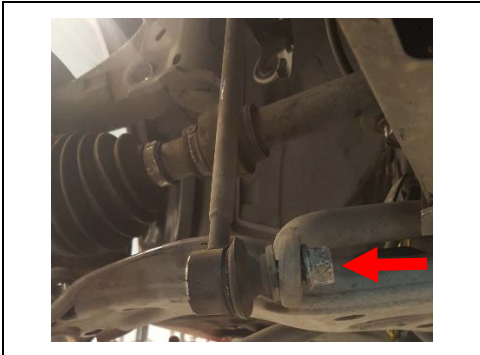

50. SEPARATE FRONT STABILIZER LINK ASSEMBLY LH AND RH

- a. Remove the nut and separate the front stabilizer link assembly LH from the front shock absorber with coil spring.

Use the same procedure for the RH side

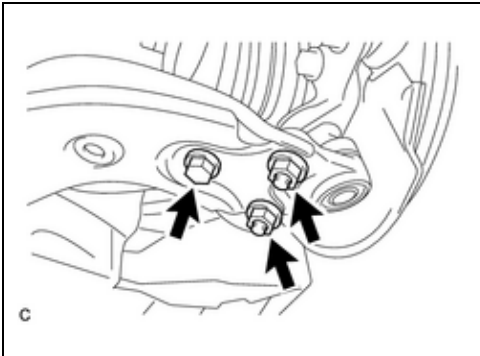

51. SEPARATE FRONT NO.1 LOWER SUSPENSION ARM SUB-ASSEMBLY LH AND RH

- a. Remove the bolt and 2 nuts and separate the front No.1 lower suspension arm sub-assembly LH from the lower ball joint LH

Use the same procedure for the RH side

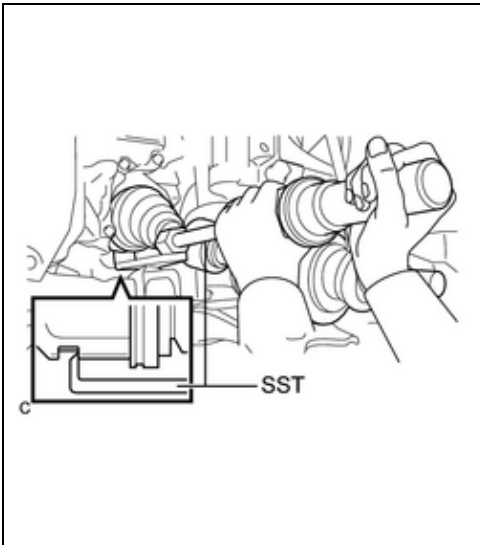

52. SEPARATE FRONT DRIVE SHAFT ASSEMBLY LH FROM THE TRANSAXLE

- a. Using SST, separate the front drive shaft assembly LH from the transaxle

SST:09520-01010
SST:09520-24010

	<ul style="list-style-type: none"> • Do not separate the drive shaft from the wheel hub. • Do not drop the front drive shaft axle
--	---

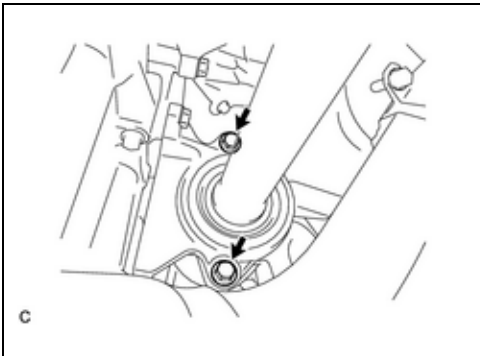

53. SEPARATE FRONT DRIVE SHAFT ASSEMBLY RH FROM THE TRANSAXLE

- a. Remove the 2 bolts and pull out the front drive shaft assembly RH from the transaxle

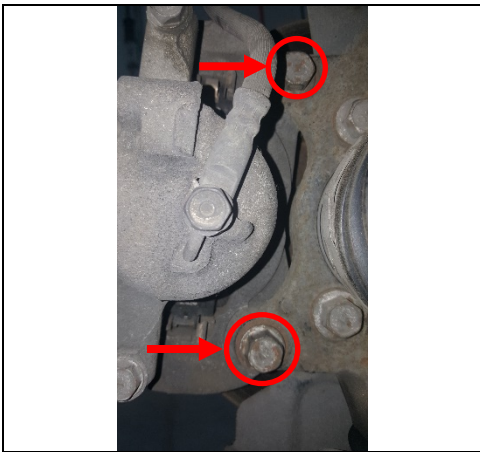

54. REMOVE FRONT DISC BRAKE CYLINDER MOUNTING LH AND RH

a. Remove the 2 bolts and front disc brake cylinder mounting from the steering knuckle



b. Using a rope or bungee cord, support the front disc brake cylinder as shown in the picture

Use the same procedure for both LH and RH side

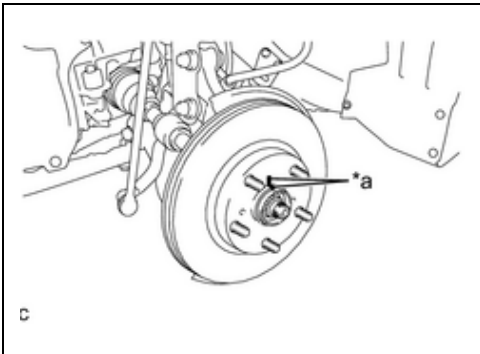

55. REMOVE FRONT DISC LH AND RH

a. Put matchmarks on the disc and the axle hub
b. Remove the front disc

*a	Matchmark
----	-----------

Use the same procedure for both LH and RH side



56. REMOVE FRONT DRIVE SHAFT ASSEMBLY AND KNUCKLE LH AND RH

a. While one person is supporting the knuckle and front drive shaft, the second person will remove the 2 bolts and 2 nuts, and separate the knuckle from the front shock absorber
b. Remove the knuckle and front drive shaft assembly from the vehicle

	<ul style="list-style-type: none">• Two people are needed to remove the knuckle and drive axle from the vehicle• Do not drop the front drive shaft axle
--	--

Use the same procedure for both LH and RH side

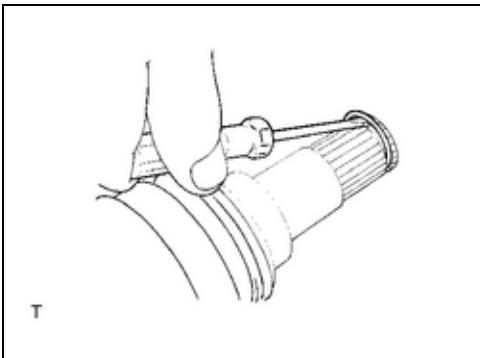

57. REMOVE FRONT DRIVE SHAFT LH HOLE SNAP RING (for LH Side)

- a. Using a screwdriver, remove the front drive shaft LH hole snap ring

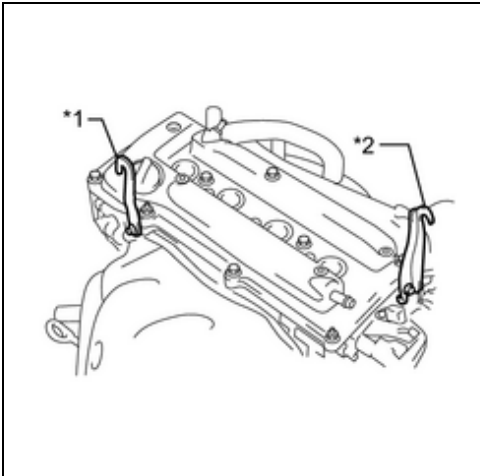

58. INSTALL ENGINE HANGER

- a. Install the 2 engine hangers with the 2 bolts

*1	No. 1 Engine Hanger
*2	No. 2 Engine Hanger

Torque:
38 N·m {387 kgf·cm, 28ft·lbf}

- b. Attach [engine support bar](#) to the engine hangers and chain block

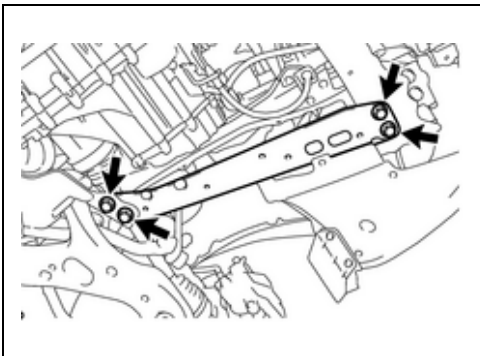

59. REMOVE REAR SIDE RAIL REINFORCEMENT SUB-ASSEMBLY

- a. Remove the 4 bolts and rear rail reinforcement sub assembly LH

Use the same procedure for RH side

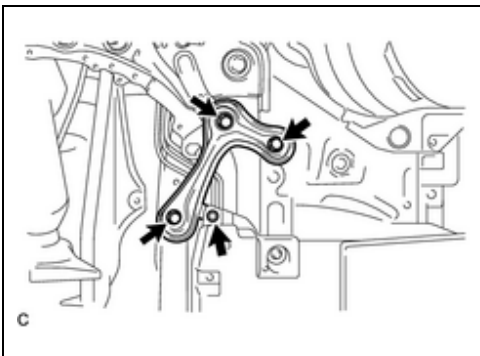

60. REMOVE FRONT SUSPENSION MEMBER REAR BRACE LH AND RH

- a. Remove the 3 bolts, clip and front suspension member rear brace LH

Use the same procedure for the RH side

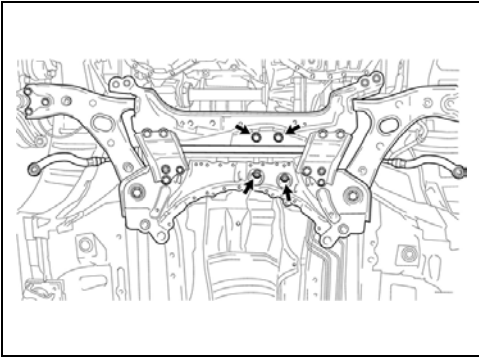

61. REMOVE FRONT SUSPENSION CROSSMEMBER SUB-ASSEMBLY

a. Remove the 2 bolts and 2 nuts, and separate the front suspension crossmember sub-assembly from the rear No.1 engine mounting insulator

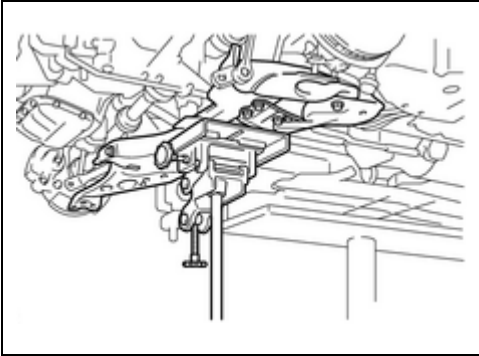

b. Using a transmission jack, support the front suspension crossmember sub-assembly

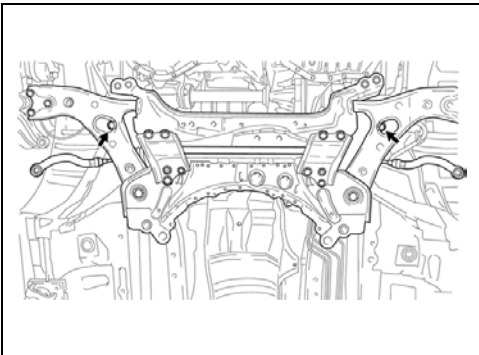

c. Remove the 2 bolts and front suspension crossmember sub-assembly

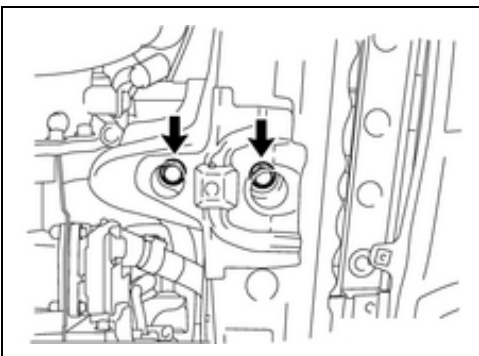

62. REMOVE FRONT CROSSMEMBER SUB-ASSEMBLY

a. Remove the 2 bolts and separate the front engine mounting insulator from the front cross member sub-assembly

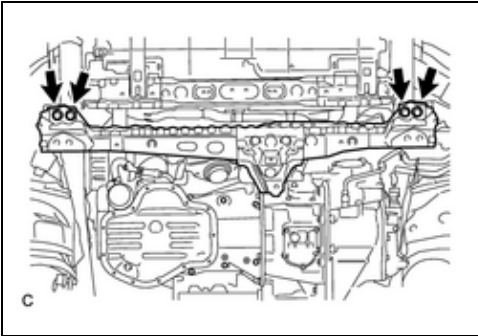

b. Remove the 4 bolts and front cross member sub-assembly

63. SUPPORT HYBRID VEHICLE TRANSAXLE ASSEMBLY

a. Support the hybrid vehicle transaxle assembly with a transmission jack



64. REMOVE ENGINE MOUNTING BRACKET LH

a. Remove the bolt and nut, and separate the engine mounting insulator LH



- Ensure that the transaxle is being supported by a transmission jack and not just the engine hangers and engine support bar alone
- Do NOT support the transaxle with just the engine support bar and engine hangers at any time

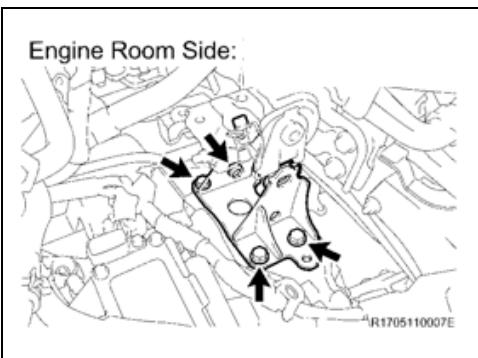

b. Remove the 4 bolts and the engine mounting bracket LH

65. REMOVE HYBRID VEHICLE TRANSAXLE ASSEMBLY



- Return to the main campaign instructions for how to remove the hybrid vehicle transaxle