



**SAFETY  
RECALL**

**SR17-28A**

DATE :	December 2017	SECTION :	18 BODY
SUBJECT:	FUEL TANK CRADLE HARDWARE		

Revision: A  
2017-11-30

THIS WARRANTY BULLETIN SUPERSEDES PREVIOUS VERSION.  
Replaced parts must be returned.

**APPLICATION**

<b>NOTICE TO SERVICE CENTERS</b> <i>Verify vehicle eligibility by checking warranty bulletin status with <b>SAP</b> or via <b>ONLINE WARRANTY SYSTEM</b> available on Service / Warranty tab of PrevoSt website.</i>	
Model	VIN
H3-41, H3-45 coaches Model Year: 2009 - 2018	
H3-45 VIP motorhomes Model Year: 2008 - 2018	
X3-45 coaches Model Year: 2011 - 2018	
XLII-45 Entertainer Model Year: 2011 - 2013	
X3-45 VIP motorhomes Model Year: 2012 - 2018	
X3-45 VIP commercial use Model Year: 2014 - 2018	
X3-45 Commuter Model Year: 2017	
<p><b>This Safety Recall does not necessarily apply to all the above-mentioned vehicles, some vehicles may have been modified before delivery. The owners of the vehicles affected by this recall will be advised by a letter indicating the Vehicle Identification Number (VIN) of each vehicle concerned.</b></p>	

**DESCRIPTION**





On vehicles affected by this recall, one end of the fuel tank cradle is attached to the frame at two locations. At these locations, a gap exists between the structural lugs and the cradle support tubing. Over time, this gap can cause the bolt torque to loosen, which could compromise the integrity of the bolt. If the cradle attachment points (i.e. both bolts) fail, the fuel cradle, complete with the fuel tank, can drop to the ground.

The vehicles will have the attachment points prepared, shimmed, and the hardware replaced.

## MATERIAL

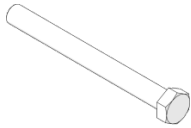
<b>NOTE</b>
Do not order separate, individual parts. Order kit number <b>SR17-28</b> .

Order kit number SR17-28 which includes:

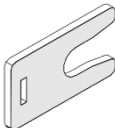
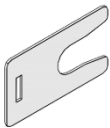
Part No.	Description	Qty
5001941 	SCREW CAP HEX M12X1.75X120 G10.9	2
500806 	SCREW CAP HEX M12-1.75X35 G10.9	4
500811 	NUT HEX STO N500 M12-1.75 G10	6
500958 	FLAT WASHER SS .531X1.062X.095 (M12,1/2)	12
030082 	SHIM U 3.175MM	4
030083 	SHIM U 0.953MM	4

## PROCEDURE

 <b>DANGER</b>
<p>Park vehicle safely, apply parking brake, stop engine. Prior to working on the vehicle, set the ignition switch to the OFF position and trip the main circuit breakers equipped with a trip button. On Commuter type vehicles, set the battery master switch (master cut-out) to the OFF position.</p> <p>Apply diesel engine lockout / tagout procedure according to local policies and regulations.</p>

**NOTE**

*Ideally, perform the bulletin with a low fuel level in the tank.*

1. Raise vehicle with safe lifting equipment.



**Figure 1: Vehicle Lifting**

2. Support the fuel tank cradle on stands.

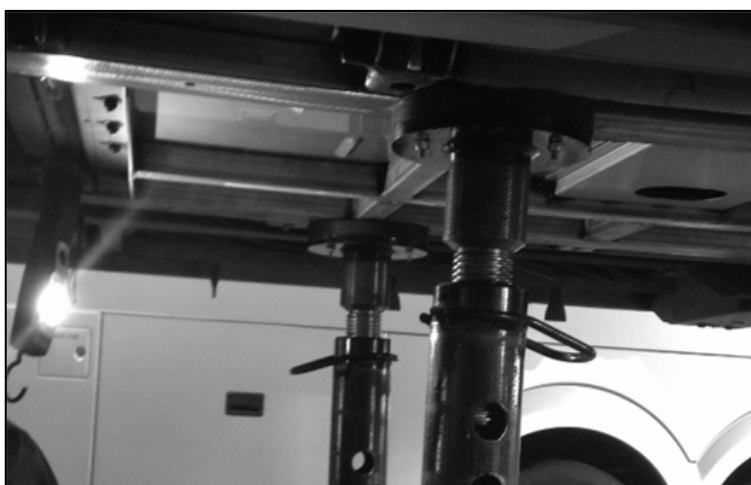

**Figure 2: Adjustable supports**

3. Locate the mounting points of the fuel tank cradle under the vehicle frame.

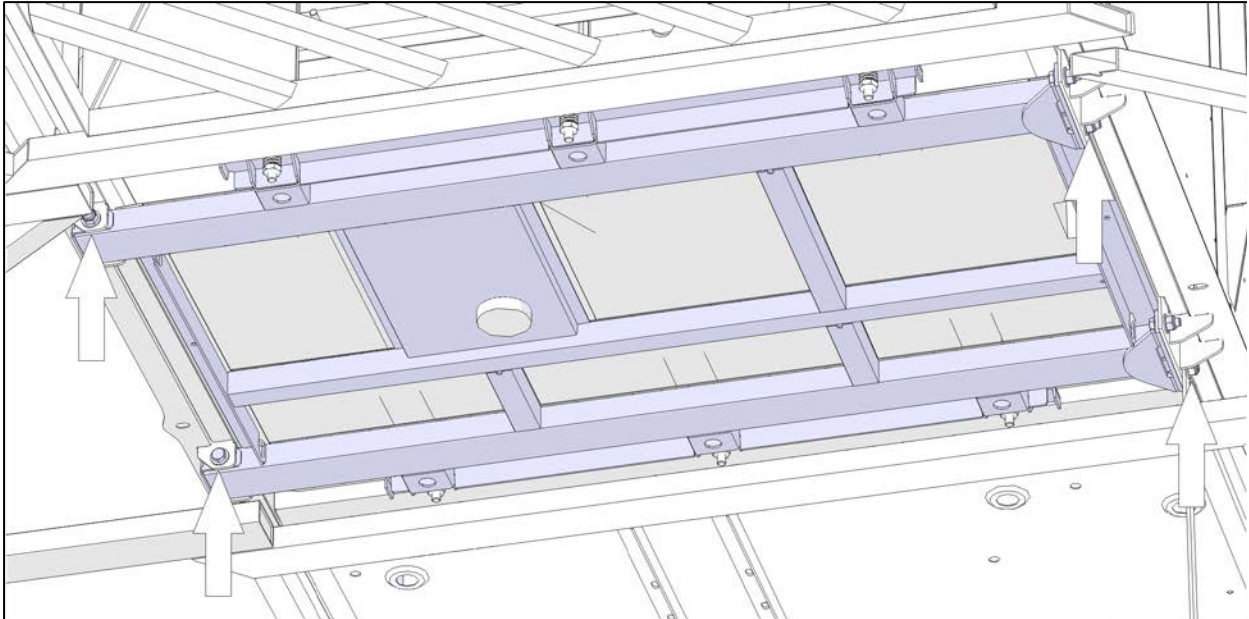

Figure 3: H Series Cradle Mounting Locations



## CAUTION

Perform replacement one screw location at a time.

4. Remove and replace the longitudinal mounting screws one at a time. (4 locations)

5. Install new hardware:

**500806**, Screw M12 35mm

**500811**, Nut M12

**500958**, Washer 2x

6. Tighten to **82 lb-ft**. Apply torque seal marks

7. Repeat on the three other locations.

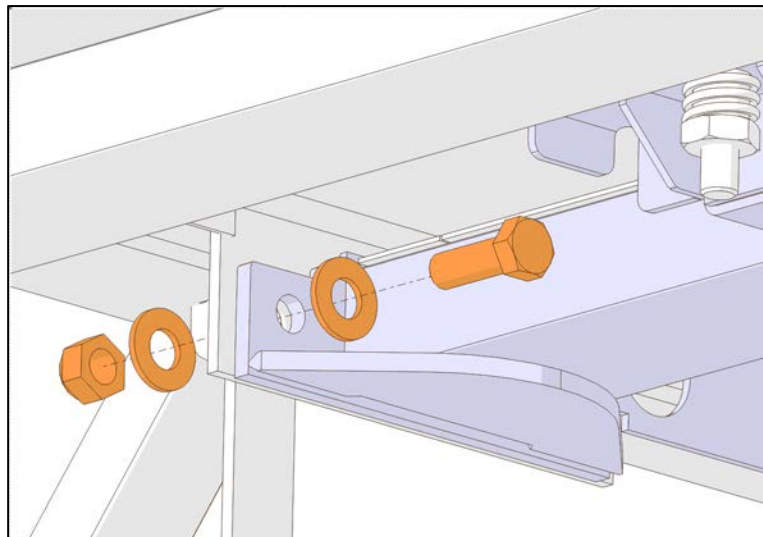

Figure 4: Longitudinal Mounting Screws (4 locations)

8. Remove one transverse mounting screw.
9. It may be required to remove static straps.

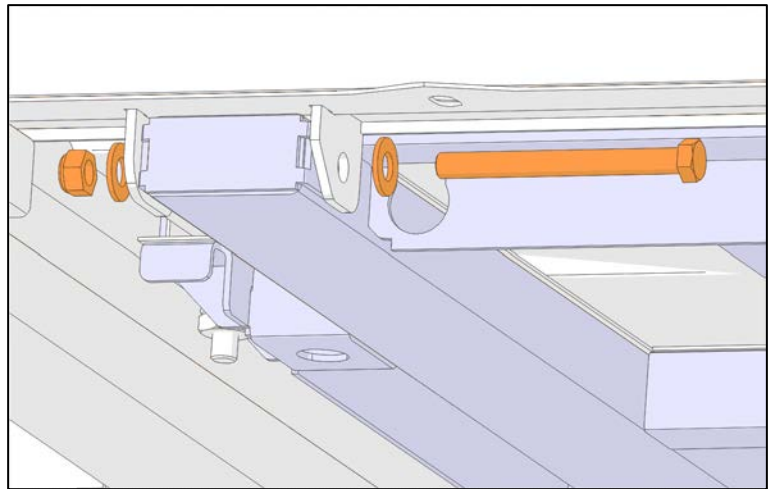

Figure 5: Transversal Mounting Screws (2 locations)

10. The mounting lugs on the vehicle frame may be bent slightly inward. Bend them slightly outward to make them straight with a hammer and chisel.

Mounting lug geometry may vary across model years.

11. Blow clean and try to insert one shim between the mounting surface of the cradle beam and the ear.

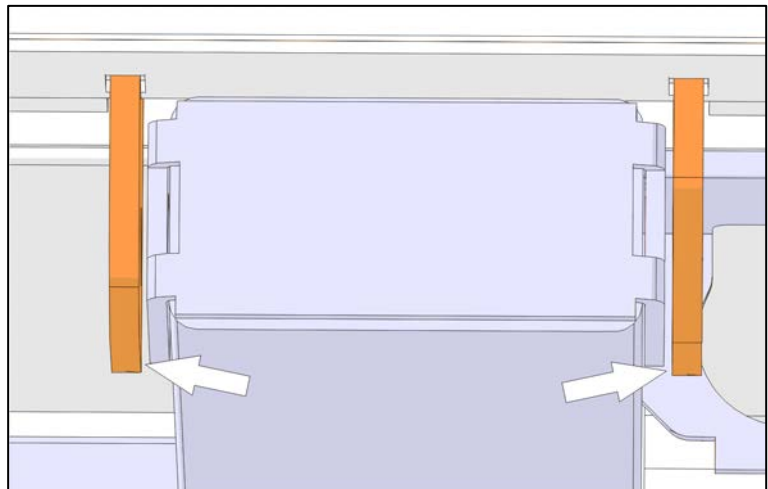

Figure 6: Mounting Lugs

12. If you feel interference while inserting the shim, the contour weld on the cradle tubing may need to be lightly ground down in this location with a thin cutting wheel to have a flat surface for the shim. (Figure 7).

13. Clean and dry the mounting surfaces.

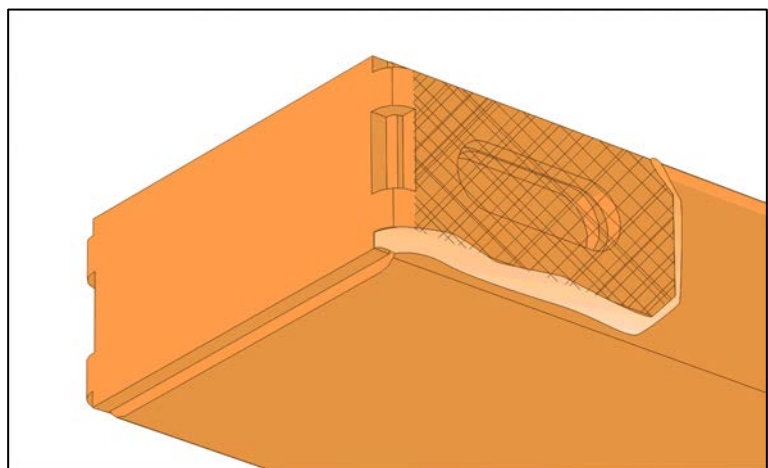

Figure 7: Cradle Tubing Mounting Surface

14. Loosely install new hardware:

**5001941**, Screw M12x120mm

**500811**, Nut M12

**500958**, Washer 2x

15. Insert the required amount of shims **030082** or **030083** between the mounting lugs and the cradle tubing.

**Note:** To ease shim insertion, you may need to pry lug and tube open with a flat head screwdriver. (Figure 8) Gently tap the shim with a hammer.

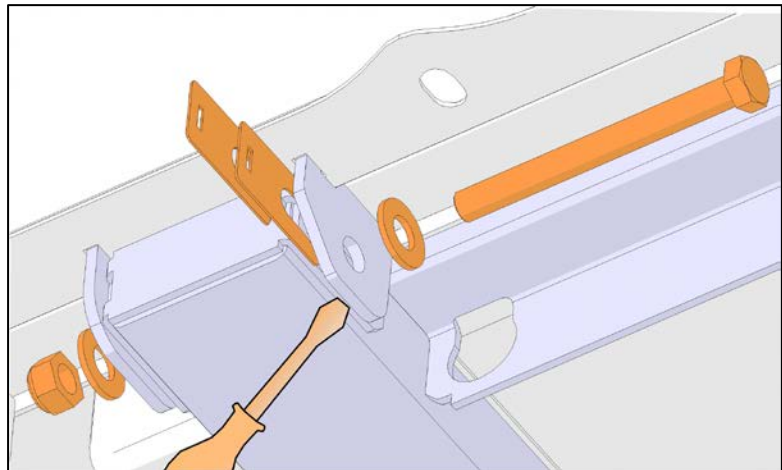

Figure 8: Screw and Shim Installation

**NOTE**

Shim arrangement will vary depending on vehicle series and model year.  
Shims may be stacked only on one or both sides of the tube.  
In all situations the shims should be snug between mounting ear and tube.

16. Tighten to **82 lb-ft**.
17. Apply torque seal mark.
18. Re-install any static strap removed earlier.
19. Return to step 8 and proceed to other side.

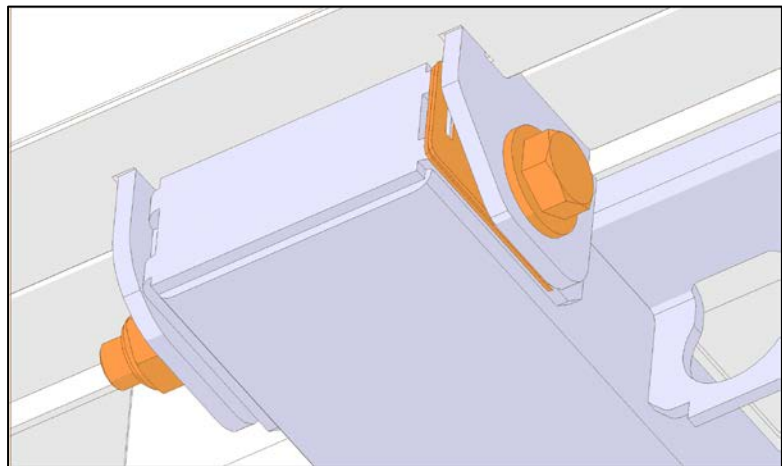

Figure 9 : End result

## PARTS DISPOSITION

All replaced parts must be returned to Prevost according to the Return Shipping Instructions available on <https://www.prevostcar.com/content/warranty-documents> for full reimbursement. A copy of the warranty claim form must be enclosed with the shipment.

Discard waste according to applicable environmental regulations (Municipal/State[Prov.]/ Federal)

## WARRANTY

This modification is covered by Prevost's normal warranty. We will reimburse you the parts and one and a half hour(s) (1.5h) of labor upon receipt of a completed A.F.A. Please submit claim via our Online Warranty System, available at [www.prevostcar.com](http://www.prevostcar.com) (under service \ warranty section). Use Claim Type: "Bulletin/Recall" and select "Safety Recall SR17-28".

Should you only wish to close the safety recall (without reimbursement), fill-in the "Safety Recall Certification Sheet" provided with this bulletin and return it to our warranty department by Email at [prevost.onlinewarranty@volvo.com](mailto:prevost.onlinewarranty@volvo.com) or by fax at 418-831-9301.

## OTHER

VBC Bulletin	N/A
Fail Code	18.08
Defect Code	09
Syst.Cond	R
Causal Part	032904

Access all our Service Bulletins on <http://techpub.prevostcar.com/en/> or scan the QR-Code with your smart phone.

E-mail us at [technicalpublications\\_prev@volvo.com](mailto:technicalpublications_prev@volvo.com) and type "ADD" in the subject to receive our warranty bulletins by e-mail.



