

SAFETY RECALL

MACK Trucks Inc.
Greensboro, NC USA



Date	Number	Release	Page
10.2017	SC0408	01	1 (11)

DANA® Steer Axle, Inspection

CHU, CXU

SAFETY RECALL INFORMATION:

(October 2017)

MACK Trucks Inc. has determined a defect relating to motor vehicle safety may exist in certain MACK CHU, CXU trucks manufactured between 03/09/2015 through 06/26/2015, and equipped with DANA® steer axles. DANA® has identified a group of steer axles manufactured between March 01, 2015 and May 17, 2015 that will require an inspection of the nut torque on the tie rod end assemblies. On certain vehicles, the castle nut and cotter pin on the steer axle may not have been tightened to specification. This could cause the tie rod to become loose in the steer axle, which would result in audible noise and/or looseness in steering. If the vehicle were continuously operated in this condition, the tie rod could disconnect from the knuckle, resulting in a complete loss of control of a vehicle's steering, which would increase the risk of a crash causing injury and/or damage to property.

MACK Trucks Inc. has received no reports of personal injury as a result of this condition. Therefore, MACK considers this as a proactive measure to protect the public and MACK's customers from the potential risk associated with this defect.

The process outlined in this recall will give you step by step instruction on how to file a recall claim, inspect suspect components, order replacement parts and close out the claim. Follow the follow the inspection procedures outlined in this Safety Recall.

VEHICLES AFFECTED:

Certain 2016 MACK CHU and CXU model trucks manufactured from March 09, 2015 through June 26, 2015, and equipped with a DANA® steer axle.

VEHICLE IDENTIFICATION NUMBERS (VIN):

The number of vehicles affected by this recall is 477 (439 USA, and 38 Canada).

Parts Ordering and Labor:

All parts orders and returns will be directed and coordinated thru the DANA® Real Time Warranty group. All Labor for Inspection's as well as parts replacement labor claims will be processed through MACK UCHP Warranty system.

For parts replacement labor claimed through MACK UCHP, the DANA® Real Time Warranty Claim # will need to be referenced in the UCHP claim, (Ex. DANxxxxxxx).

Decommissioning the Truck for Inspection or Repair:

1. Secure the vehicle for service by parking on a flat and level surface, placing the transmission in neutral, applying the parking brake, turning the ignition key to the OFF position, and chocking the front wheels.

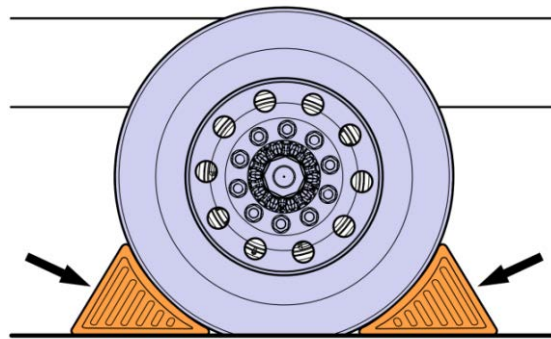

2. Disconnect the cable from the battery's negative (ground) terminal.

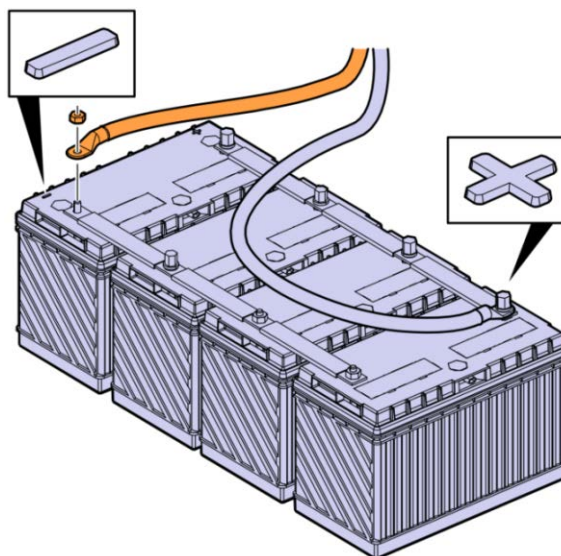

RECALL CLAIM PROCESS

NOTE
The Illustrations shown in this document are used for reference only and may differ slightly from the actual vehicle being serviced. However, the replacement procedure is represented as accurately as possible.

Step # 1 (Before calling the Real Time Warranty Group):

3. Verify the Vehicle Identification Number (VIN) of the vehicle is on the recall list.
4. Locate the identification tags on the front of the steer axle. Write down everything on the tag.

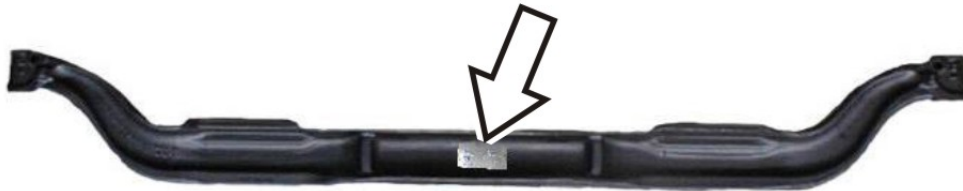

5. Locate the recall inspection form on the last page of this recall.
6. Before you call DANA[®] RTW to start a claim please fill out a recall inspection form. It is important that the information below and what you found during your inspection of the steer axle is documented and sent to RTW before you call to open a claim.
 - Repair Order Number
 - Dealer Code
 - Complete 17digit Vehicle Identification Number (VIN) Located on truck door jam, drivers side
 - Axle model (Example: E1202I)
 - Axle serial number (Example: MY01778644). **NOTE:** See tag located on the carrier assembly
 - In-service date of the vehicle
 - Vehicle mileage
 - Inspection data

7. If your inspection identifies that components may need to be replaced you will need to take pictures of the damage parts and the position of the cotter pin hole. It's important to remember that RTW will be using the pictures you send to determine if components need to be replaced. If the pictures are out of focus, too light, too dark, too far away or too close-up the process will be delayed until new pictures are submitted. Use the example below as a guide of what your pictures should resemble.



Tie Rod Arm Taper Bore

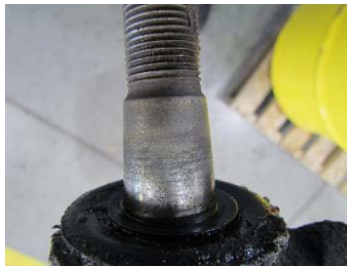

Tie Rod End Taper Stud



Back of Tie Rod Nut



Nut Rotation



Cotter Pin Hole Position

8. Email the recall inspection form and pictures if required to Spicer.rtw@dana.com. You can visit Dana.com for additional contact information and warranty guidelines.
9. Enter the repair order number in the subject line of your email.

Step # 2 (Time to Call Real Time Warranty, 877-777-5360, ext. #3):

1. Real Time Warranty will review the information you sent while you are on the phone and give you direction to the next step.
 - a. If the inspection data shows that there is no looseness between the tie rod end and tie rod arm, RTW will approve the labor for the inspection and close the claim.
 - b. If components need to be replaced RTW will order the parts and approve the labor for the repair.
2. When a repair has been authorized the damaged parts must be returned to DANA[®] for review. Below you will find the shipping instructions and address.
3. For tracking purposes please write this RMA number on the outside of the shipping container and in the shipping address. RMA-1200

Warranty Return Material Shipping Instructions

- For shipments over 150 LBS, Call Penske[®] Logistic at 855-456-3867.
- For shipments under 150 LBS, Call DANA[®] Logistics at 260-481-3778.

Ship To:
DANA Inc. CV Warranty Return Center
6515 Maumee Western
Maumee, OH. 43537
Att: RMA-1200

NOTE
If material is shipped to the warranty center without a copy of the claim, the shipment will be returned "Collect" to the sender.

NOTE
If material is returned to DANA [®] and there is no failure found or the wrong material was sent, the shipment will be returned "Collect" back to the sender.

RECALL CLAIM PROCESS

1. Ensure the forward and rear of at least one of the drive axle tires is chocked so the vehicle cannot move during this procedure.

2. Locate and mount a flexible magnetic base dial indicator on the tie rod arm so that the indicator tip can be centered on the threads of the stud just above the nut.



Dial Indicator Mounting Position



Dial Indicator Tip Must be Placed on The Stud

3. With someone in the cab of the truck turning the steering wheel (with the engine off) just enough to cause movement in the wheels, document how much movement is found on each side of the steer axle. Record results on the supplied form.
4. The next step is to remove the cotter pins and check for proper nut torque. Put a paint mark across one side of the nut and top of the stud. With a torque wrench and a 32 mm (1.25 in) socket, torque the nut in a clockwise (tighten) direction until the nut just starts to rotate or you reach 176 Nm (130 ft-lb). Record the findings on the recall form.

NOTE
Do not exceed 230 Nm (170 ft-lb) when tightening the nut in step 4.



Paint Mark to Identify Nut Rotation



Check Nut Torque – Do Not Exceed 230 Nm (170 ft-lb)

5. If there is no rotation of the nut at 176 Nm (130 ft-lb), install a new cotter pin and return the truck to service.
6. If you found rotation of the nut before you reached 130 ft. lbs., we can now torque the nut to 176 Nm (130 ft-lb). Using the paint mark, record the amount of movement to the nut. Example: Use the paint mark as the 12:00 position, if the nut rotates $\frac{1}{4}$ turn to reach 176 Nm (130 ft-lb), document the nut rotated as the 3:00 position.



Re-torque to 176 Nm (130 ft-lb)

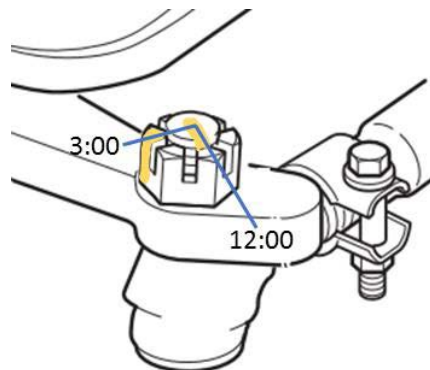

Record Rotation on Nut

7. With the nut torqued to 176 Nm (130 ft-lb), advance the nut so that the cotter pin hole is aligned with a slot in the nut, re-install the dial indicator and check for tie rod stud movement once again. Record results on the form supplied.

NOTE

Never back the nut off to align the cotter pin hole to the nut slot. Torque may reach 230 Nm (170 ft-lb) to obtain proper alignment.

8. Any tie rod stud with movement after proper nut torque and alignment will require the replacement of that knuckle and tie rod.

9. One last check. After the nut has been aligned with a slot in the nut, the cotter pin hole **CANNOT** be above the top of the nut as shown in the figure below. Any cotter pin hole that is above the top of the nut surface will require the replacement of the knuckle and tie rod end.



Good Cotter Pin Hole Position



Cotter Pin Hole at Maximum Height

Recall 17E041 Inspection Form

Date: _____

Repair Order Number: _____

Dealer Code: _____

Complete 17 Digit VIN: _____

Axle model: _____

Axle serial number: _____

In-service date of the vehicle: _____

Vehicle mileage: _____

1. Document the amount of total movement on the dial indicator. (Example: .002”).

Left Hand Tie Rod Movement Reading	Amount of Movement
Right Hand Tie Rod Movement Reading	Amount of Movement

2. Using the images below mark the amount of rotation on the nut after the nuts where torqued to 176 Nm (130 ft-lb).



Left Side



Right Side

3. Document the amount of movement between the tie rod end and the tie rod arm after you re-torqued the nut to 176 Nm (130 ft-lb). If there is no movement answer “**NONE**”.

Left Hand Movement After Re-Torque	Amount of Movement
Right Hand Movement After Re-Torque	Amount of Movement

Commissioning the Truck for Operation:

1. Connect the battery cable to the negative (ground) terminal.

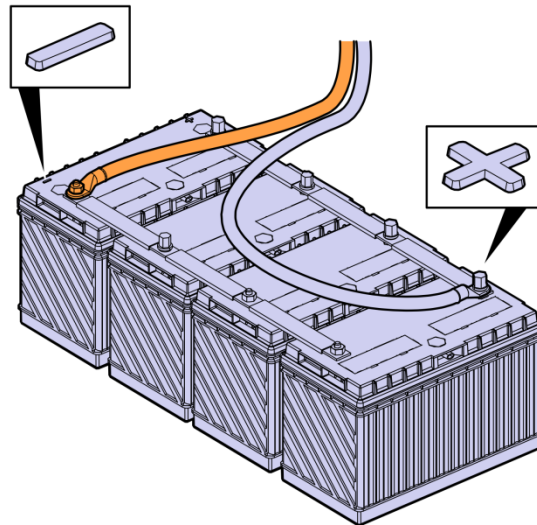

2. Remove the wheel chocks.

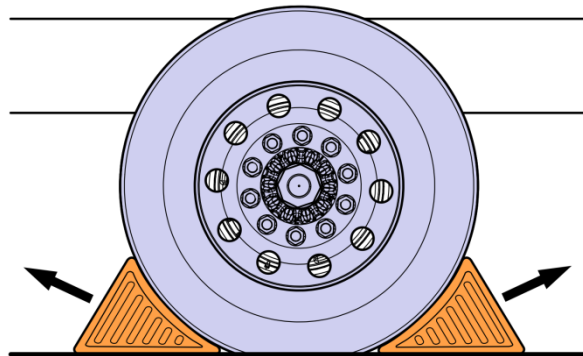

3. Test-drive the truck to ensure proper operation of the replacement draglink.

NOTE
Ensure the steering wheel is correctly positioned before and after test driving the truck.

NOTE
If the steering wheel is not positioned correctly, perform a truck alignment procedure.

Reimbursement:

This repair is covered by an authorized Safety Recall campaign. Reimbursement is obtained through the normal claim handling process.	
	UCHP Reimbursement
Claim Type (used only when uploading from the Dealer Business System)	40
Recall Status	
Vehicle repaired per instructions	1-Modified per instructions
MACK Labor Codes	
Primary Labor Code Inspected tie rod ends for movement and proper torque (Both sides)	6438-08-02-01 (0.6 hrs)
Knuckle Replacement/Front Axle Member Replace (Per Side)	6111-03-02-01 (2.9 hrs)
Tie Rod Replacement (Per Side)	6435-03-02-02 (0.6 hrs)
Alignment	6010-06-01-01 (1.1 hrs)
Time to take charge of vehicle and determine campaign status	1700-16-01-01 (0.3 hrs)
Causal Part	21987342
Authorization Number	C6590

Take-charge time is not included in the labor code for this operation. Take charge may be eligible, but can only be used once per vehicle repair visit. If the vehicle is having other warranty repairs performed, take-charge should be charged to the warranty repair, otherwise take-charge can be charged to this Safety Recall campaign.