

2003-08 MAZDA6, 2006-07 MAZDASPEED6, 2004-08 RX-8 - DRIVER AIR BAG INFLATOR FINAL REPAIR - SAFETY RECALL 1417G

UPDATED September 20, 2023 – Added updated photos on pages 3 and 10

RECALL NOTE

- Recall 8215F has been superceded to 1417G.

A. VEHICLE INSPECTION PROCEDURE

1. Verify that the vehicle is within the following ranges:

Model	VIN Range
2003-2008 Mazda6	All
2006-2007 Mazdaspeed6	All
2004-2008 RX-8	All

- If the vehicle is within the above ranges, proceed to Step 2.
 - If the vehicle is not within the above ranges, return vehicle to the customer or inventory.
2. Perform a Warranty Vehicle Inquiry using your eMDCS System and inspect vehicle for Campaign Labels **Recall 1417G** attached to the vehicle’s hood or bulkhead. Refer to eMDCS System - Warranty Vehicle Inquiry Results table below.

NOTE: Be sure to verify Recall number as the vehicle may have multiple Recall labels.

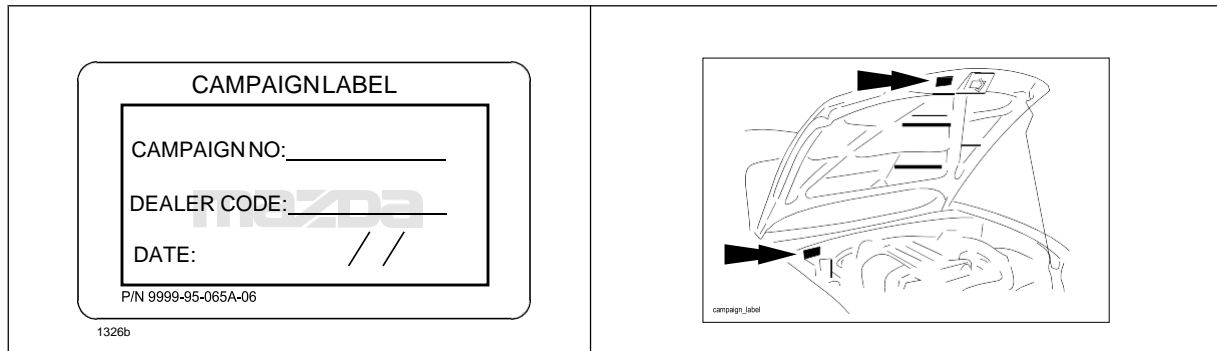

eMDCS System - Warranty Vehicle Inquiry Results:

If eMDCS displays:	Campaign Label is:	Action to perform:
RECALL 1417G OPEN	Present	Contact the Warranty Hotline at (877) 727-6626 option 3 to update vehicle history.
	Not present	Proceed to "B. REPAIR PROCEDURE".
RECALL 1417G PRELIM LTR	Present	Contact the Warranty Hotline at (877) 727-6626 option 3 to update vehicle history.
	Not present	NOTE: All Vehicles are in open status.
RECALL 1417G CLOSED	Present	Return vehicle to inventory or customer.
	Not present	Complete a label and apply to vehicle's hood or bulkhead.
RECALL 1417G is not displayed	Does not apply	Recall does not apply to this vehicle. Return vehicle to customer.

B. REPAIR PROCEDURE



2003-2008 Mazda6, 2006-2007 Mazdaspeed6:

Driver-Side Air Bag Inflator Replacement Procedure (Autoliv Inflator):

NOTE: To identify an inflator, confirm the following identification code pasted on the label.

- PSDI: “HC” is printed on the label (Original Part)
- PSDI-X: “PSDI-X” is printed on the label (Recall 8215F part)
- ADPS-1.3A MOD: “ADPS-1” is printed on the label (Autoliv part)

DO NOT INSTALL THE AIR BAG MODULE IF THE SPELLING OF “AUTOLIV” IS DIFFERENT THAN BELOW. THE LABEL MUST HAVE “AUTOLIV” SPELLED CORRECTLY. CONTACT DEALER ASSISTANCE GROUP (“DAG”) IMMEDIATELY IF THE LABEL ON YOUR AIR BAG IS DIFFERENT.

PSDI	PSDI-X	ADPS-1.3A MOD
 <p>PSDI</p>	 <p>PSDI-X</p>	 <p>ADPS-1.3A MOD</p>

Parts Information: The service parts are available in one box [Inflator (A), 4 Nuts (B), and CE label (C)].

NOTE: The CE label can be discarded. It is for EU regulation markets.

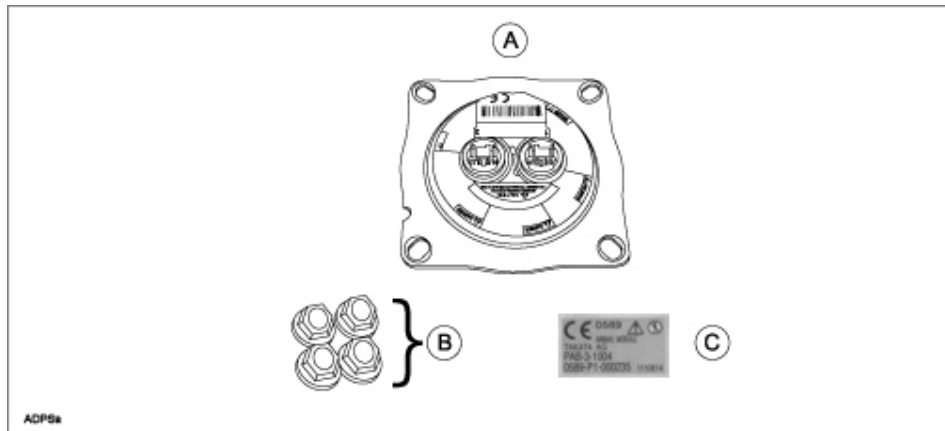

Outline:

1. Remove the inflator (A) from the air bag module.

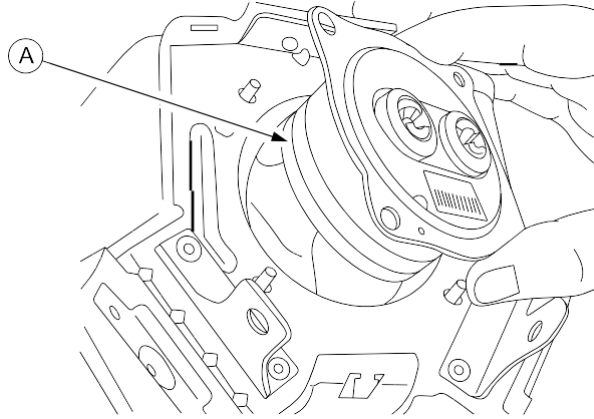

2. Install modified inflator.

NOTE: A Diffuser is installed in the airbag module if recall 8215F was previously performed. DO NOT use the diffuser if present. Remove it if it is installed in the airbag module. Vehicles previously repaired under Recall 8215F are not subject to this campaign.

3. Pack and return the removed inflator as follows:

IMPORTANT: Be sure to follow the packing and shipping instructions provided in the carton and in Attachment IV, Air Bag Inflator Return Instructions.

CAUTION:

- All the removed Inflators must be returned to a designated location. Be sure to keep the carton box which was used to deliver the new inflator, and use it for the part returning. This authorized box must be mandatory used for shipping special goods like airbag inflator.
- Pack the old inflator in the box exactly in the same manner as the new inflator was packed.

Air Bag Module Removal:

WARNING:

- Perform the replacement in a clean environment. Oil, grease, water, etc. that come in contact with components may cause the air bag modules to fail to deploy in an accident, which may cause serious injury. Do not allow oil, grease, water, etc., to spill or make contact with the airbag components.
- Inserting a screwdriver, etc., into the connector of an air bag module may damage the connector and cause the air bag module to deploy improperly, which may cause serious injury. Do not insert any foreign objects into the connectors.
- Do not disassemble the vehicle what is instructed here.
- Do not make an attempt to directly supply electrical power to the module and the inflator.
- Keep the module face of the pad surface upwards at all times, except during replacement.
- Do not use the module and new inflator if they were dropped on the ground.
- Avoid module and inflator exposure to temperatures of 194 degrees F (90 degrees C) or more.

1. Turn the ignition switch to the LOCK position.
2. Record the customer's preset radio stations.
3. Disconnect the negative battery cable and wait for one (1) minute or more.
4. Remove the driver-side air bag module.
 - a. Remove the covers (A).
 - b. Remove the bolts (B).
 - c. Disconnect the connectors (C). Using a flathead screwdriver, pry out the connector's stopperplate.

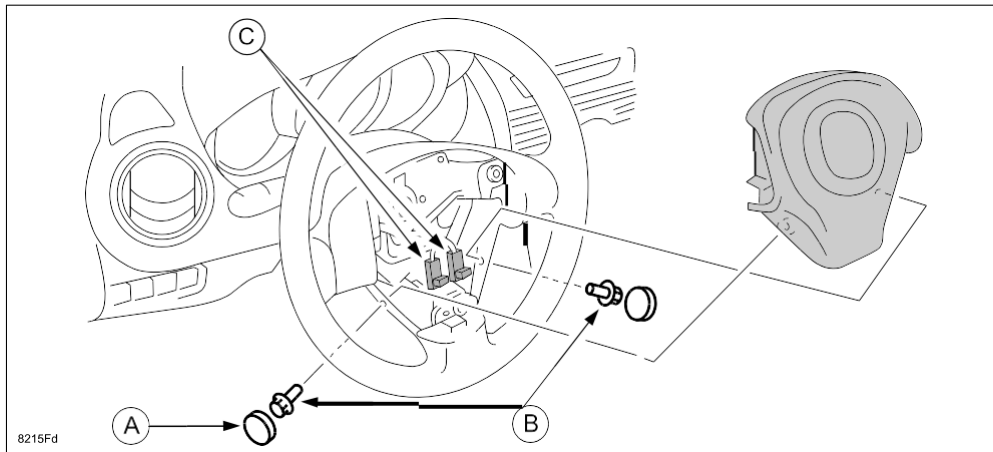

CAUTION:

- Be careful when prying out the stopper plate (A). Otherwise, damage to the stopper plate could occur. Or if it pops off and is lost, it is not available as a separate part.
- The stopper plate must be pried up before disconnecting the connector. Otherwise, the connector could be damaged if trying to disconnect it with the stopper plate engaged.
- Use extreme care when disconnecting the connector. Otherwise, damage to the connector could occur.

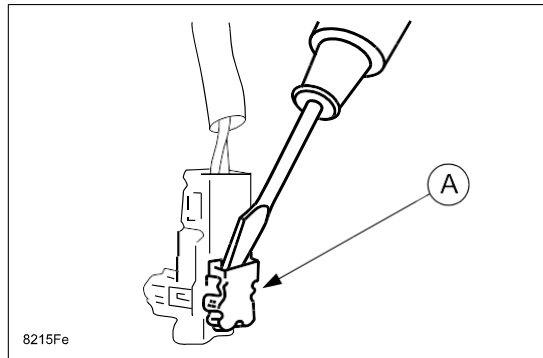

- d. Remove the air bag module.

Inflator Replacement (Autoliv Inflator):

NOTE: A Diffuser is installed in the air bag module if recall 8215F was previously performed. **DO NOT** use the diffuser if present. Remove it if it is installed to the air bag module. **Vehicles previously repaired under recall 8215F are not subject to this campaign.**

1. Set the airbag face down onto a surface that will not scratch or damage the airbag face.
2. Remove the 4 nuts, then remove the inflator (A) from the air bag body. Discard the original nuts.

NOTE: DO NOT use an impact wrench.

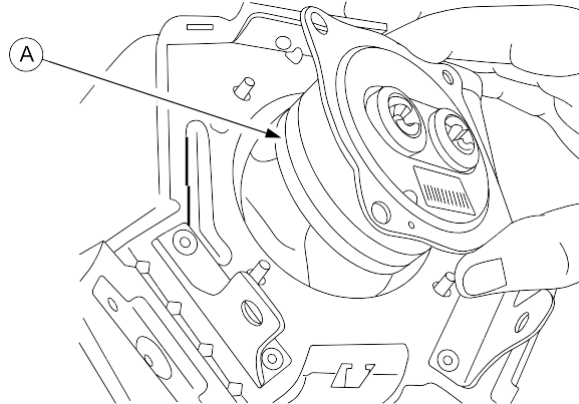
**CAUTION:**

- DO NOT touch the bolts or the cloth.
 - DO NOT drop nuts or foreign materials in the air bag body.
3. Remove the diffuser. A Diffuser is installed in the air bag module if Recall 8215F was previously performed. **Vehicles previously repaired under recall 8215F are not subject to this campaign.**

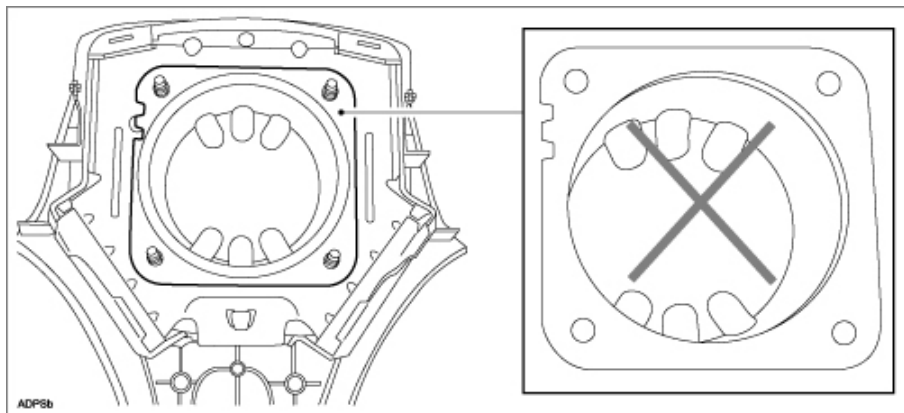

ADP8b

4. Peel off the dust-proof seal and confirm the two terminals of red (R) and yellow (Y) layouts correctly as shown.

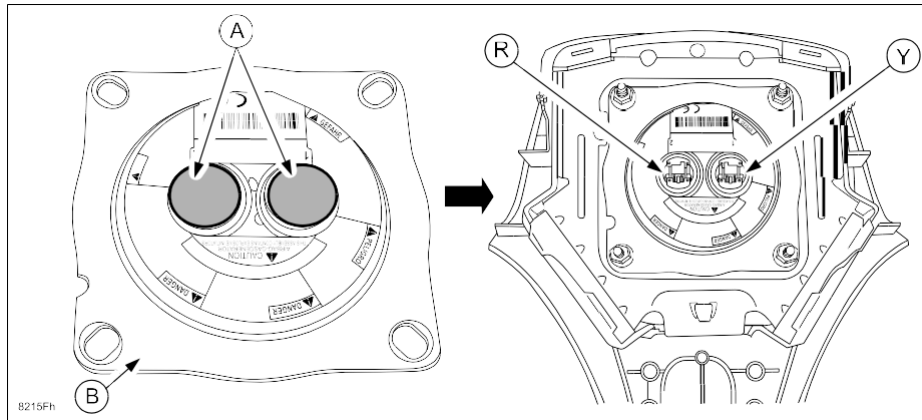

5. Tighten the new nuts (with self-lock) finger tight first, then to the specified torque in the order shown.
Tightening Torque: 34 ± 3.5 in-lb (3.9 ± 0.4 Nm)

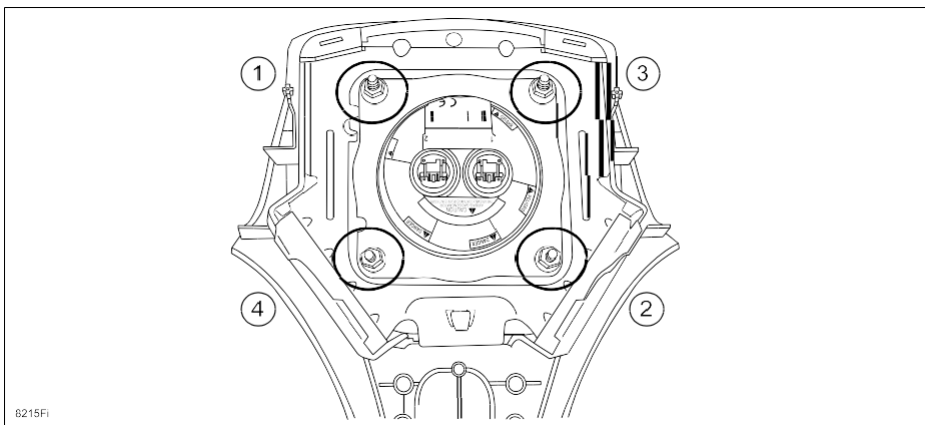

CAUTION: DO NOT over tighten the nut or the stud bolt could be forced to be pulled out from its press-fit position. Make sure to use the correct tightening torque.

Air Bag Module Reinstallation:

1. Install the driver-side air bag module.
 - a. Re-connect the connectors (A) to air bag module, securely locking the connectors by depressing the stoppers on the connector back.

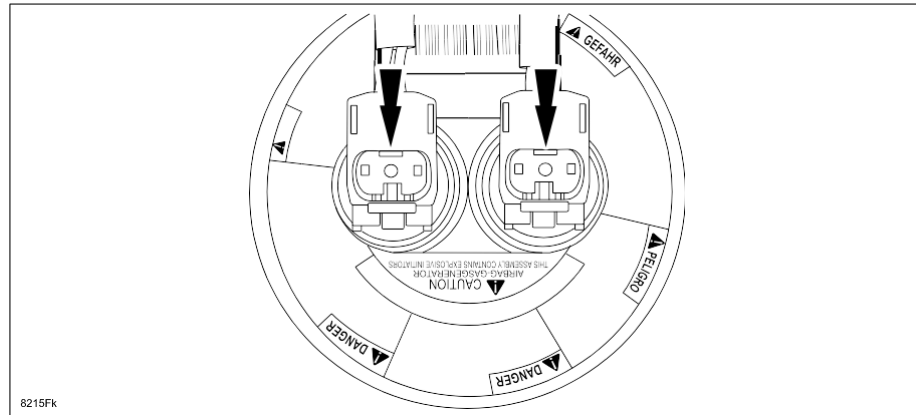

- b. Install the air bag module (B).
 - c. Install the bolts (C).
- Tightening Torque: 70 - 103 in-lbf. (7.9 - 11.7 Nm)**
- d. Install the covers (D).

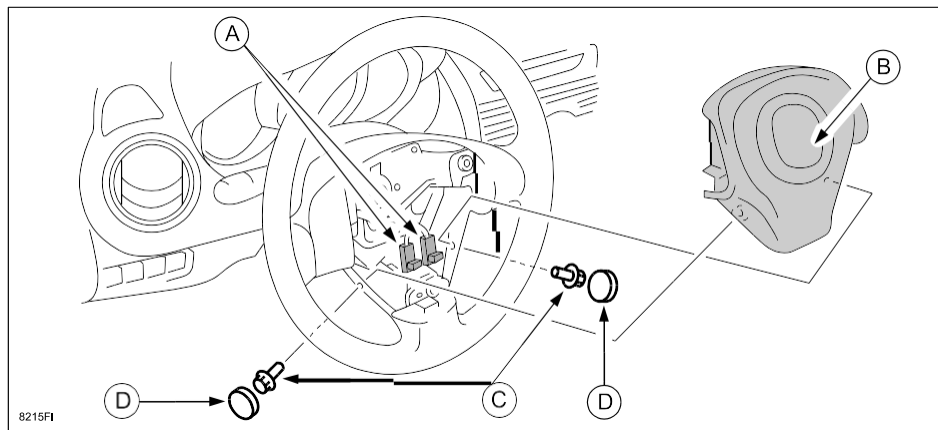

2. Reconnect the negative battery cable.
3. Turn the ignition switch to the ON position.
4. Verify that the air bag system warning light illuminates for approx. 6 sec., then goes out.

NOTE: If the air bag system warning light does not operate in the manner described above, there is a malfunction in the system. Inspect the system following the on-board diagnostic system procedure according to MS3 online or the Workshop Manual (section 08 Restraints).

5. Re-enter the customer's preset radio stations.
6. Proceed to "C. CAMPAIGN LABEL INSTALLATION".



2004-2008 RX-8:

Driver-Side Air Bag Inflator Replacement Procedure (Autoliv Inflator only):

NOTE: To identify an inflator, confirm the following identification code pasted on the label.

- PSDI: "HC" is printed on the label (Original Part)
- PSDI-X: "PSDI-X" is printed on the label (Recall 8215F part)
- ADPS-1.3A MOD: "ADPS-1" is printed on the label (Autoliv part)

DO NOT INSTALL THE AIR BAG MODULE IF THE SPELLING OF "AUTOLIV" IS DIFFERENT THAN BELOW. THE LABEL MUST HAVE "AUTOLIV" SPELLED CORRECTLY. CONTACT DEALER ASSISTANCE GROUP ("DAG") IMMEDIATELY IF THE LABEL ON YOUR AIR BAG IS DIFFERENT.

PSDI	PSDI-X	ADPS-1.3A MOD
 <p>PSDI</p>	 <p>PSDI-X</p>	 <p>ADPS-1.3A MOD</p>

Parts Information: The service parts are available in one box [Inflator (A), 4 Nuts (B), Plate (C) and CE label (D)].

NOTE: The CE label can be discarded. It is for EU regulation markets.

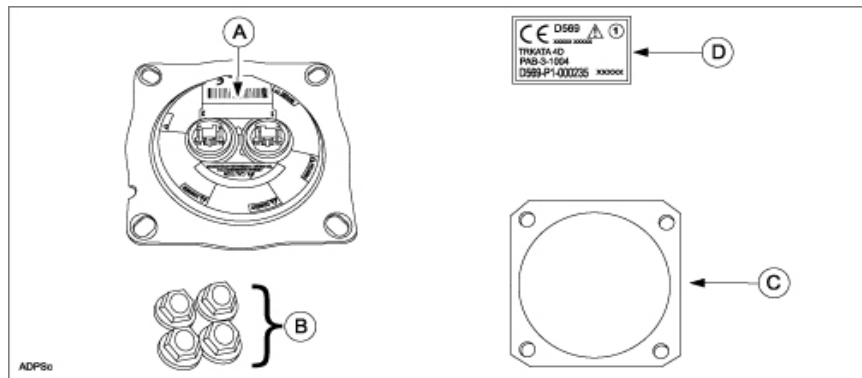

Outline:

1. Remove the inflator (A) from the air bag module.

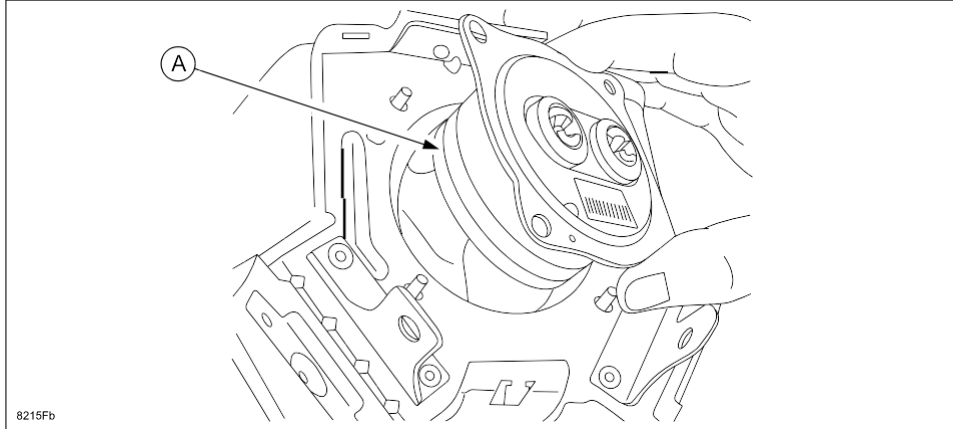

2. Pack and return the removed inflator as follows:

IMPORTANT: Be sure to follow the packing and shipping instructions provided in the carton and in Attachment IV, Air Bag Inflator Return Instructions.

CAUTION:

- All the removed Inflators must be returned to a designated location. Be sure to keep the carton box which was used to deliver the new inflator, and use it for the part returning. This authorized box must be mandatory used for shipping special goods like airbag inflator.
- Pack the old inflator in the box exactly in the same manner as the new inflator was packed.

Air Bag Module Removal:**WARNING:**

- Perform the replacement in a clean environment. Oil, grease, water, etc. that come in contact with components may cause the air bag modules to fail to deploy in an accident, which may cause serious injury. Do not allow oil, grease, water, etc., to spill or make contact with the airbag components.
 - Inserting a screwdriver, etc., into the connector of an air bag module may damage the connector and cause the air bag module to deploy improperly, which may cause serious injury. Do not insert any foreign objects into the connectors.
 - Do not disassemble the vehicle beyond what is instructed here.
 - Do not make an attempt to directly supply electrical power to the module and the inflator.
 - Keep the module face of the pad surface upwards at all times, except during replacement.
 - Do not use the module and new inflator if they were dropped on the ground.
 - Avoid module and inflator exposure to temperatures of 194 degrees F (90 degrees C) or more.
1. Turn the ignition switch to the LOCK position.
 2. Record the customer's preset radio stations.
 3. Disconnect the negative battery cable and wait for one (1) minute or more.
 4. Remove the driver-side air bag module.
 - a. Remove the covers (A).
 - b. Remove the bolts (B).
 - c. Disconnect the connectors (C). Using a flathead screwdriver, pry out the connector's stopperplate.

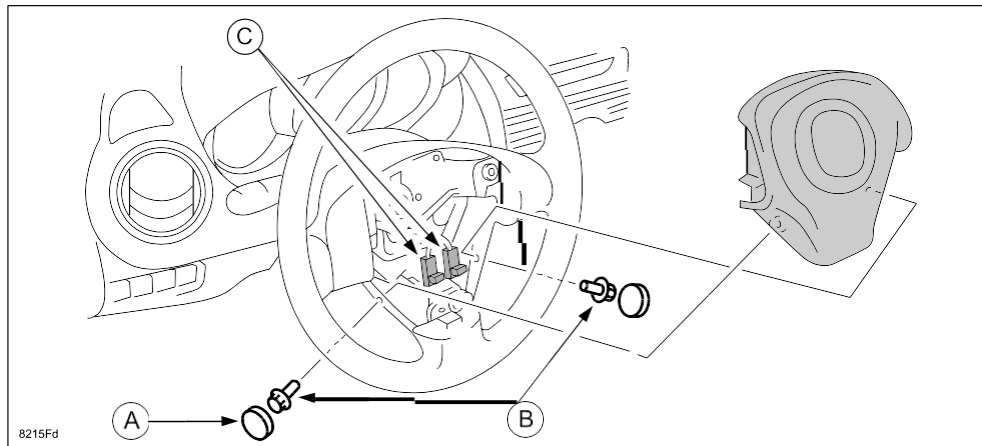

CAUTION:

- Be careful when prying out the stopper plate (A). Otherwise, damage to the stopper plate could occur. Or if it pops off and is lost, it is not available as a separate part.
- The stopper plate must be pryed up before disconnecting the connector. Otherwise, the connector could be damaged if trying to disconnect it with the stopper plate engaged.
- Use extreme care when disconnecting the connector. Otherwise, damage to the connector could occur.

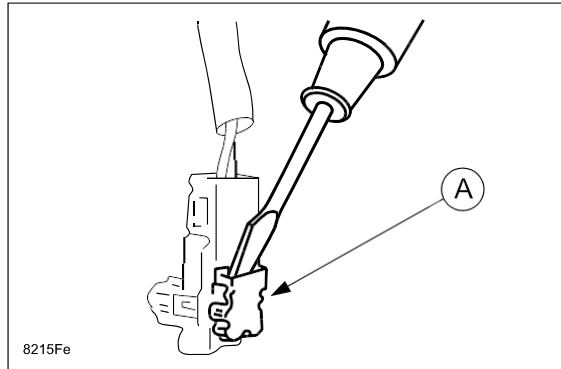

- d. Remove the air bag module.

Inflator Replacement (Autoliv Inflator only):

1. Set the airbag face down onto a surface that will not scratch or damage the airbag face.
2. Remove the 4 nuts, then remove the inflator (A) from the air bag body. Discard the original nuts.

NOTE: DO NOT use an impact wrench.

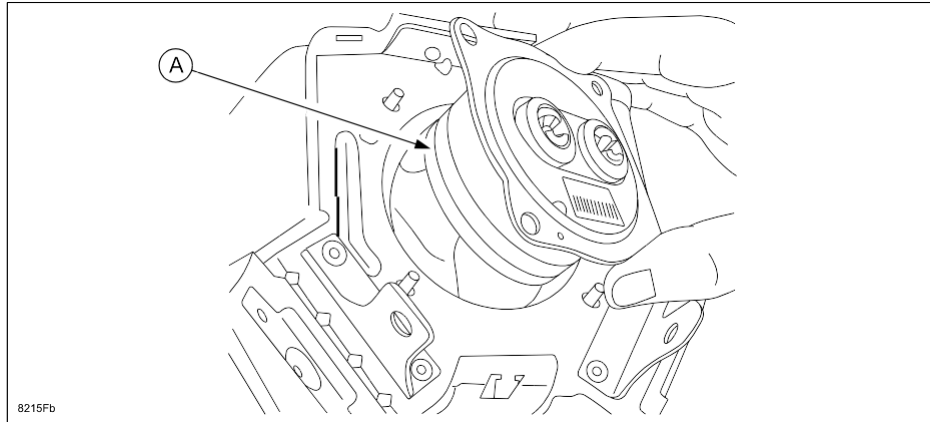

CAUTION:

- DO NOT touch the bolts or the cloth.
- DO NOT drop nuts or foreign materials in the air bag body.

3. Add the plate (A) and install new ADPS-1.3A MOD inflator (B) and 4 new nuts (C).

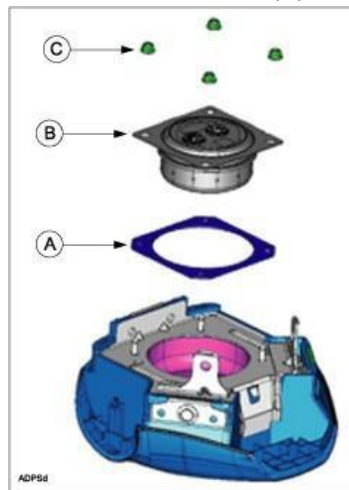

4. Peel off the dust-proof seal and confirm the two terminals of red (R) and yellow (Y) layouts correctly as shown.

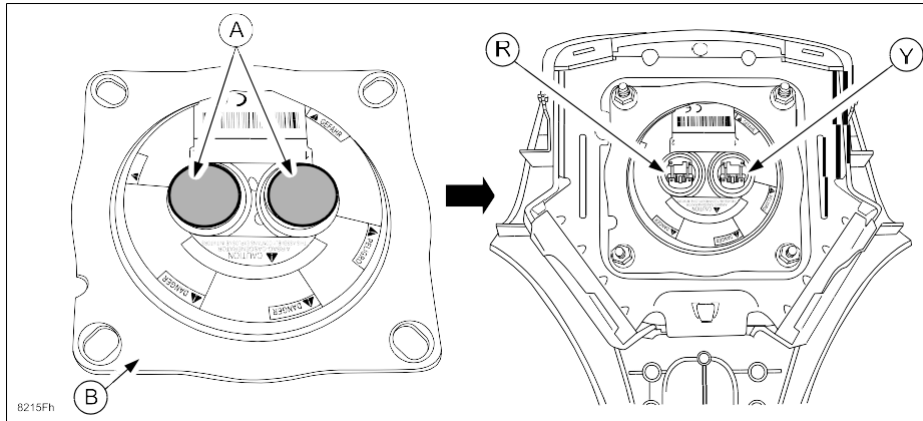

5. Tighten the new nuts (with self-lock) finger tight first, then to the specified torque in the order shown.
Tightening Torque: 34 ± 3.5 in-lb (3.9 ± 0.4 Nm)

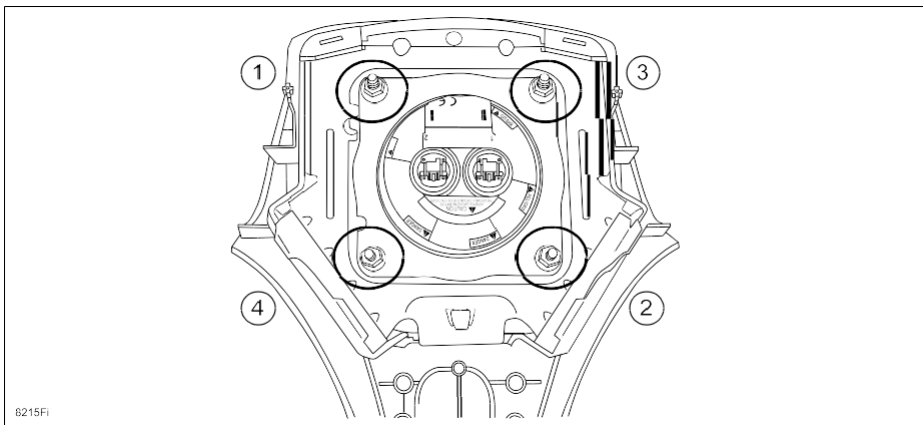

CAUTION: DO NOT over tighten the nut or the stud bolt could be forced to be pulled out from its press-fit position. Make sure to use the correct tightening torque.

Air Bag Module Reinstallation:

1. Install the driver-side air bag module.
 - a. Re-connect the connectors (A) to air bag module, securely locking the connectors by depressing the stoppers on the connector back.

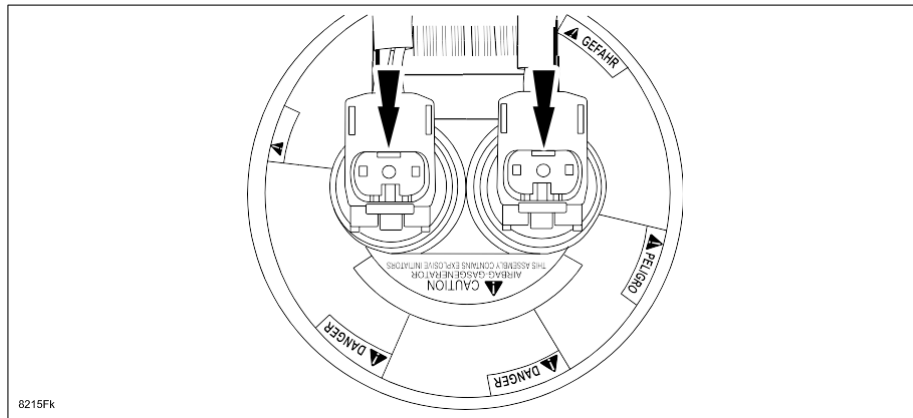

- b. Install the air bag module (B).
 - c. Install the bolts (C).
 - Tightening Torque: 70 - 103 in-lbf. (7.9 - 11.7 Nm)**
 - d. Install the covers (D).

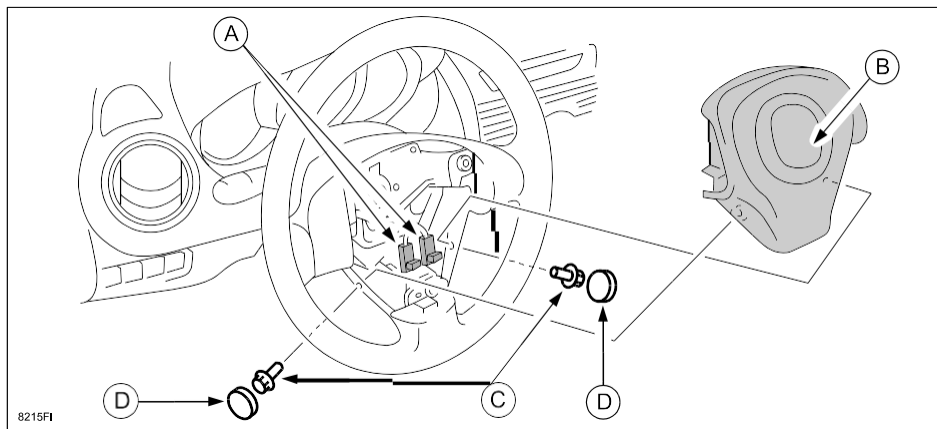

2. Reconnect the negative battery cable.
3. Turn the ignition switch to the ON position.
4. Verify that the air bag system warning light illuminates for approx. 6 sec., then goes out.

NOTE: If the air bag system warning light does not operate in the manner described above, there is a malfunction in the system. Inspect the system following the on-board diagnostic system procedure according to MS3 online or the Workshop Manual (section 08 Restraints).

5. Re-enter the customer's preset radio stations.
6. Proceed to "C. CAMPAIGN LABEL INSTALLATION".

C. CAMPAIGN LABEL INSTALLATION

1. Fill out a blue "Campaign Label" (9999-95-065A-06) with Campaign No: "1417G", your dealer code, today's date.

1326b

CAMPAIGN LABEL

CAMPAIGNNO: _____

DEALER CODE: _____

DATE: / /

P/N 9999-95-065A-06

2. Affix it to the hood or bulkhead as shown:

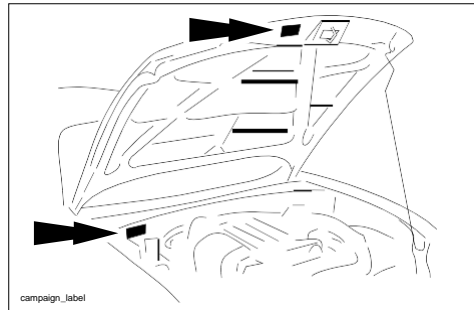

3. Return the vehicle to customer.