



# SAFETY RECALL BULLETIN

SUBJECT: <b>WINDSHIELD WIPER MOTOR – SAFETY RECALL CAMPAIGN</b>			No: <b>SR-17-003</b>
			DATE: <b>July 2017</b>
			MODEL: <b>2007–2013 Outlander</b>
CIRCULATE TO:	<input checked="" type="checkbox"/> GENERAL MANAGER	<input checked="" type="checkbox"/> PARTS MANAGER	<input checked="" type="checkbox"/> TECHNICIAN
<input checked="" type="checkbox"/> SERVICE ADVISOR	<input checked="" type="checkbox"/> SERVICE MANAGER	<input checked="" type="checkbox"/> WARRANTY PROCESSOR	<input checked="" type="checkbox"/> SALES MANAGER

## PURPOSE

This bulletin provides directions for replacing the windshield wiper motor. This bulletin is meant to be used in conjunction with bulletin SR-16-009, “Windshield Wiper Link – Safety Recall Campaign.” SR-16-009 must be performed where indicated before this bulletin can be resumed.

## BACKGROUND

Water can potentially drop down onto the front wiper motor through a gap between the front deck garnish (the body piece between the hood and windshield) and the front windshield. If this occurs, water could potentially collect in the area of the wiper motor breathing hole. If the wiper motor is not operating, this water can then potentially enter the wiper motor through the breathing hole. If this occurs, such water intrusion over time may cause internal corrosion and/or electrical conduction failure resulting in non-operation of the windshield wiper motor.

If the windshield wiper motor stops operating, the driver will not be able to activate the windshield wipers, reducing driver visibility under certain conditions and increasing the risk of a vehicle crash.

## AFFECTED VEHICLES

2007 – 2013 Outlander

### IMPORTANT

Affected new or used inventory vehicles must be repaired before the vehicle is sold/delivered. Dealers must check their inventory vehicles’ VINs on the Warranty Superscreen to verify whether the vehicle is involved in this recall campaign. It is a violation of Federal law for a dealer to sell/deliver a new motor vehicle or any new or used item of motor vehicle equipment (including a tire) covered by the notification under a sale or lease until the defect or noncompliance is remedied.

## REQUIRED EQUIPMENT

- Precision Flathead Screwdriver
- Adjustable Wrench
- Straight Edge
- Ornament Remover (Trim Stick)
- Hose
- Scissor
- Pry Bar
- Masking Tape
- Marker

**NOTE:** This recall C1613S–Wiper Motor is meant to be performed at the same time as C1613R–Wiper Link replacement. Thus, the labor time is significantly reduced for that campaign. Performing this campaign C1613S–Wiper Motor and not performing C1613R–Wiper Link at the same time will prevent a dealer from claiming adequate labor time if C1613R–Wiper Link is done in the future.

## WIPER MOTOR REPLACEMENT PROCEDURE

**CAUTION** Do NOT mix old parts with new parts.

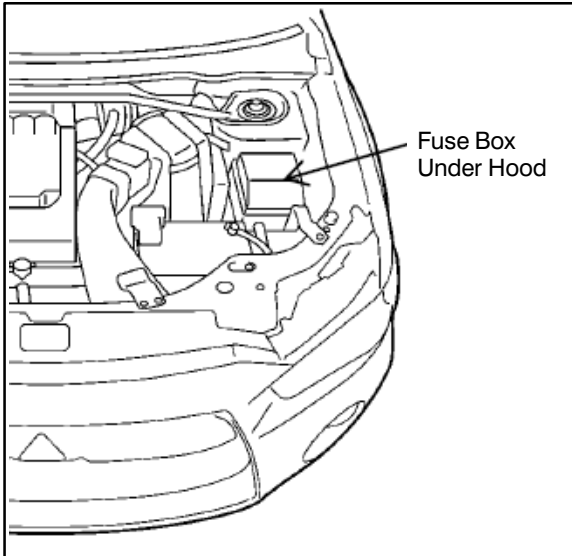

1. Obtain the Fuse Remover from the engine compartment fuse box.

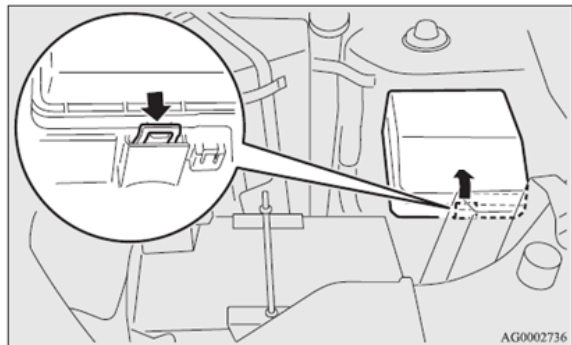

- a. Open the hood.
- b. Unlock the fuse box cover by pushing on the lock lever.

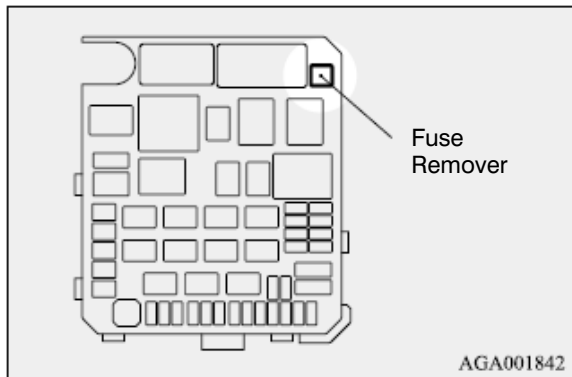

- c. Remove the Fuse Remover.

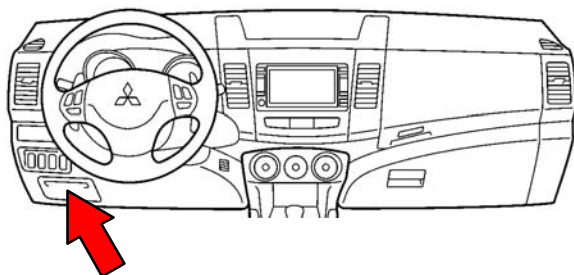

2. Locate the side box inside the vehicle.

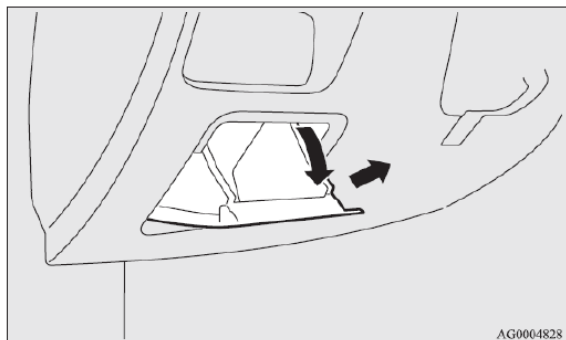

3. Open the side box.

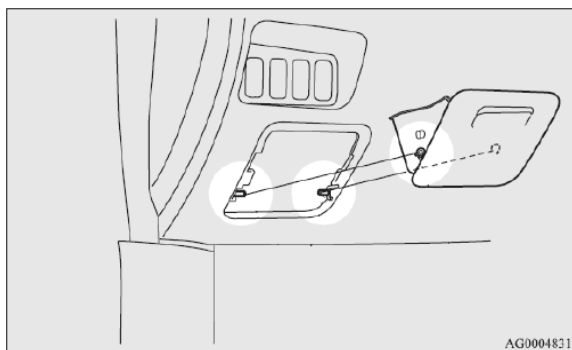

4. Unhook and remove the side box.

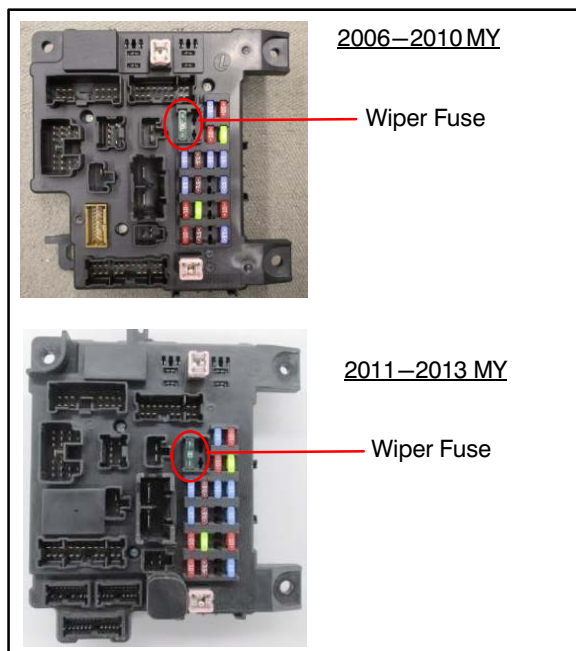

5. Using the Fuse Remover, locate and remove the green (30 A) Wiper Fuse.

Refer to “**How to Use Fuse Remover**” instructions below.

### How to Use Fuse Remover

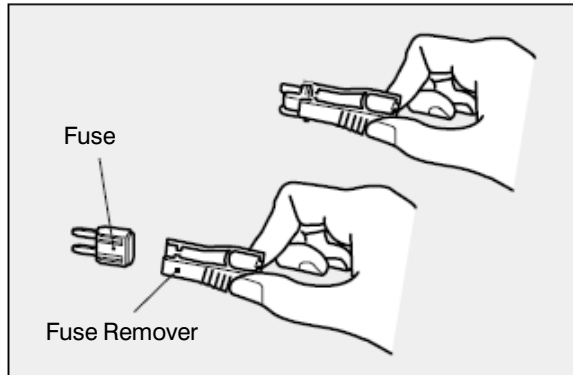

#### **⚠ WARNING**

A Fuse Remover **MUST** be used to remove fuses. Use of other tools such as pliers can potentially result in thermal incidents.

#### **!! IMPORTANT !!**

Before marking the windshield wiper positions, lift the wiper blade from the windshield and set it back down to ensure that they are resting in their intended positions.

#### **!! IMPORTANT !!**

Use a fender cover, towel, or similar accessory to protect the fender.

6. Attach masking tape to the windshield and mark the wiper blades' positions as shown.



7. Remove the wiper arm blade assembly.

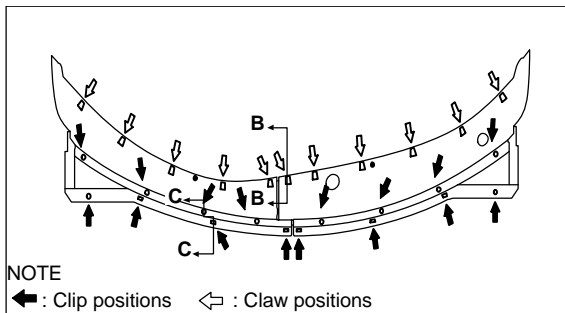

8. Remove front deck garnish.

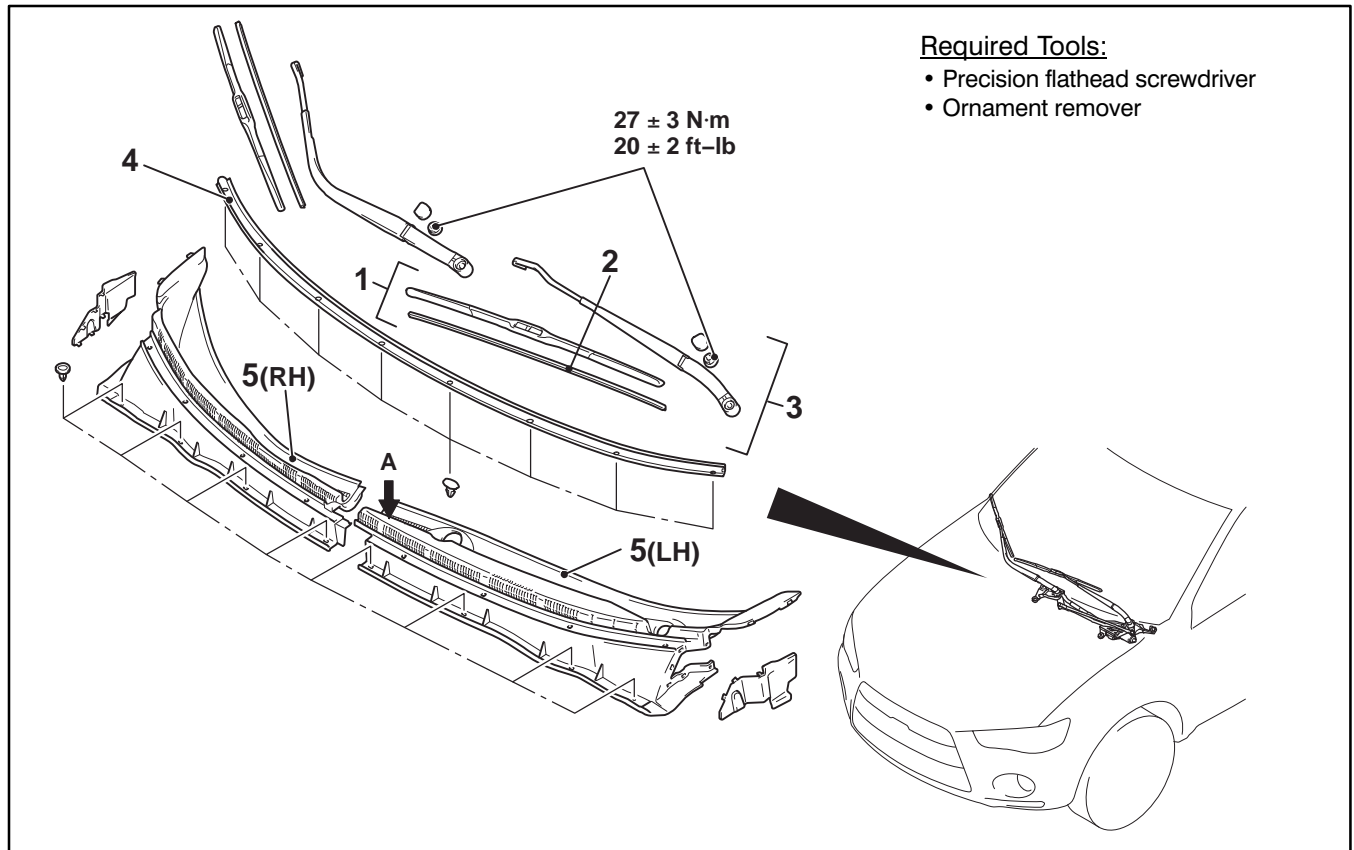

9. Remove the passenger side hood rear weatherstrip from the deck garnish.

**NOTE:** Do not remove the driver side hood rear weatherstrip from the deck garnish (for easier reassembly).

10. Protect the windshield with a protective slit hose.

a. Make a protective slit hose as shown below.

#### Making a Protective Slit Hose

1. Hose Length: Approx. 33 in. (85 cm)



2. Cut entire length of hose



Cross Section of hose

**Before**

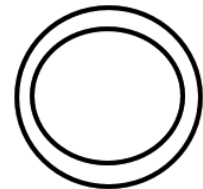

**After**



- b. Cover the edge of the windshield with the protective slit hose.

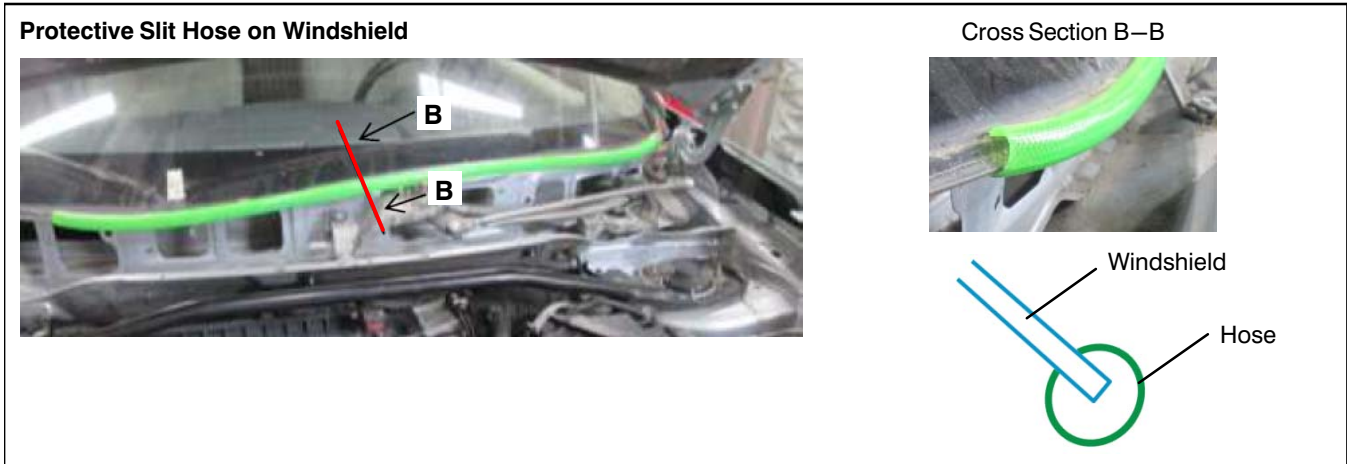

- 11. Unbolt the wiper link assembly, disconnect the wiper motor connector, and remove the wiper link assembly from the vehicle.

**CAUTION** Clamp the wiper link assembly at the connection pipe only.



- 12. Place the wiper link assembly in a vice with the motor axle pointing up.

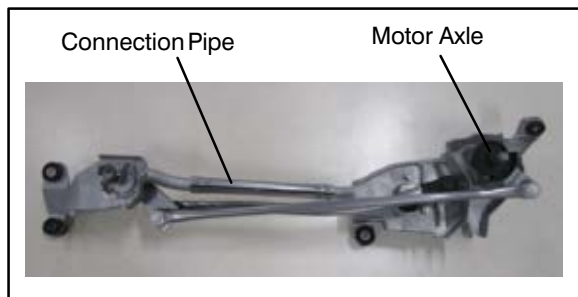

**CAUTION: Clamp ONLY the connection pipe section.**

13. Use a pry bar or similar device to separate the wiper link rod from the wiper link plate. Insert the pry bar and lift using leverage in area shown below.

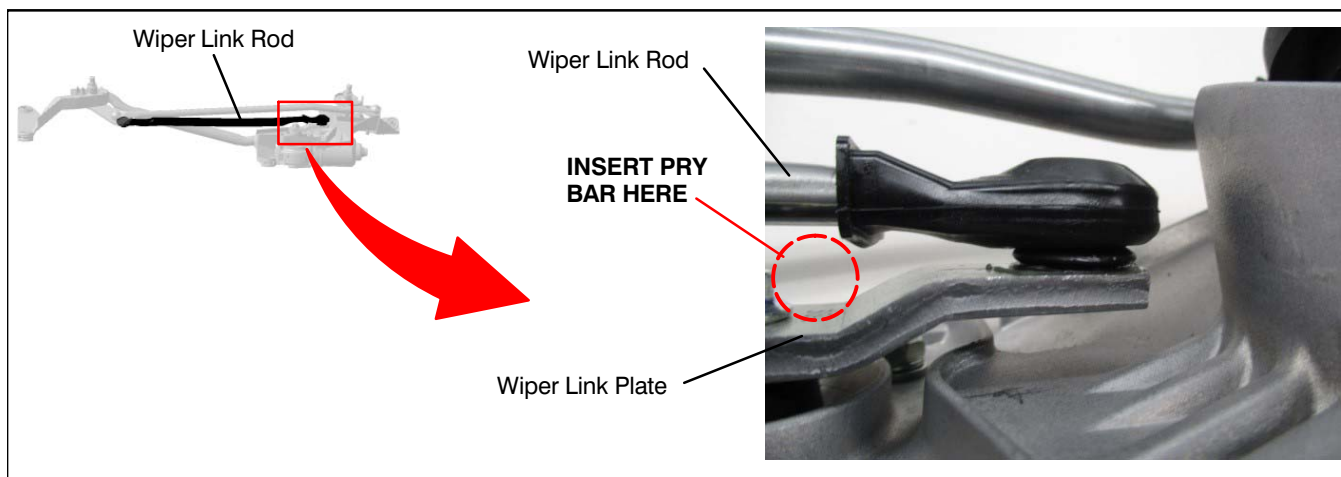
**CAUTION**

Turn the link plate slowly to avoid internal damage to the wiper motor.

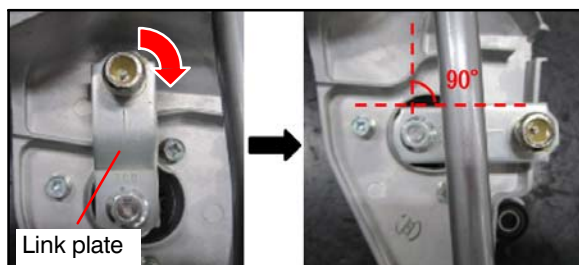

14. Turn the link plate 90 degrees clockwise.

15. Remove the wiper motor.



16. Obtain the new countermeasure wiper motor (part # 8250B137).

17. Verify that the new wiper motor has a breathing hole cap with a water proof cloth, as shown.

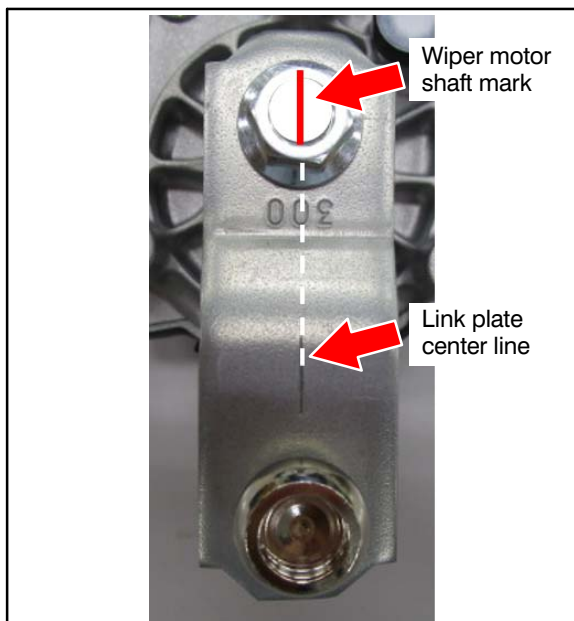

18. Use a straight edge to line up the link plate center line and the center of the wiper motor shaft, and use a marker to create a visible marking on the wiper motor shaft.

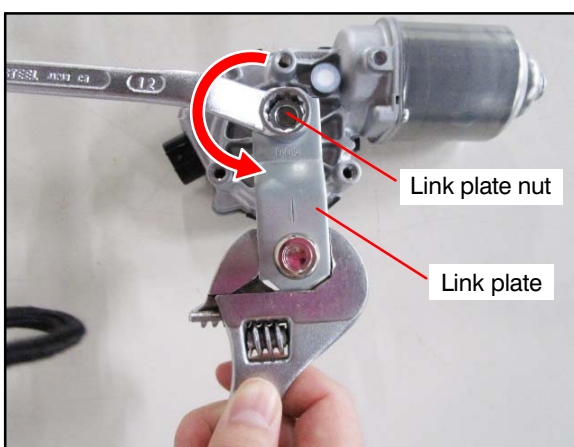

19. Hold the link plate in place with an adjustable wrench while removing the link plate nut.



20. Check the knurling on the wiper motor shaft for any debris. Clean off any debris with a clean rag.





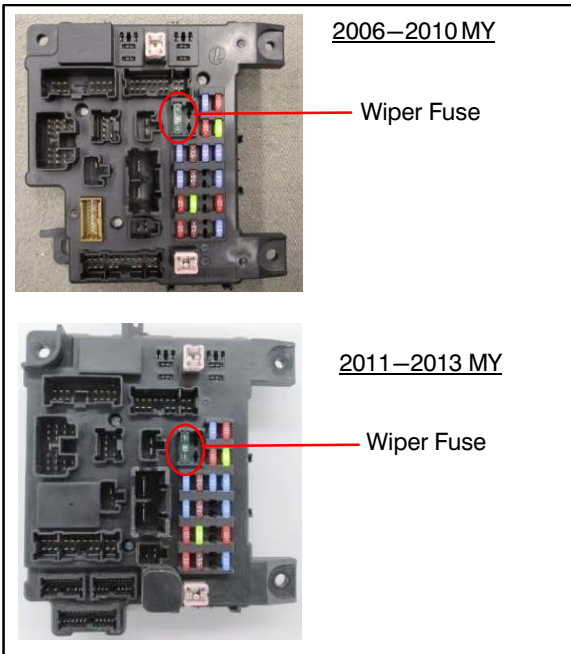

24. Reinstall the Wiper Fuse.

- 25. Turn the ignition switch to “ACC” or “ON”.
- 26. Switch the windshield wiper switch to “LO” and back to “OFF” to move wiper link to initial position.
- 27. Remove protective slit hose from windshield.
- 28. Install the passenger side wiper arm at the marked position.
  - a. Tighten nut to  $20 \pm 2$  ft–lb ( $27 \pm 3$  Nm).



- 29. Confirm wiper operation in wiper “INT” mode for 10 cycles. If either of the following abnormal behavior is observed, perform the appropriate correction.
  - a. Abnormal behavior 1: Wiper blade moves up briefly then stops.
    - (1) Correction procedure: Turn link plate clockwise.
  - b. Abnormal behavior 2: Wiper blade moves down briefly during the start of wiper operation.
    - (1) Correction procedure: Turn link plate counterclockwise.

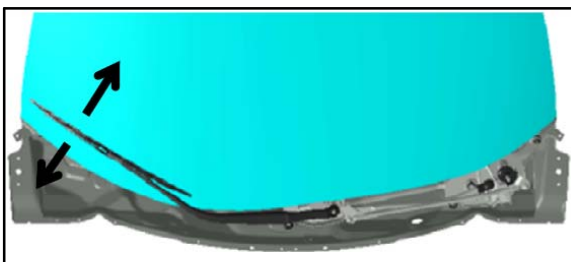

30. Remove the passenger side wiper arm.
31. Reinstall the front deck garnish.
32. Reinstall hood rear passenger side weatherstrip.
33. Reinstall the wiper arm blade assemblies to the marked locations.
34. Tighten nuts to  $20 \pm 2$  ft-lb ( $27 \pm 3$  Nm).
35. Verify wiper motor operation by turning the vehicle ignition to "ACC" or "ON" and activate the windshield wipers in "LO" and "HI" positions.
36. Return the Fuse Remover to the fuse box.
37. Close the fuse box lid and hood.

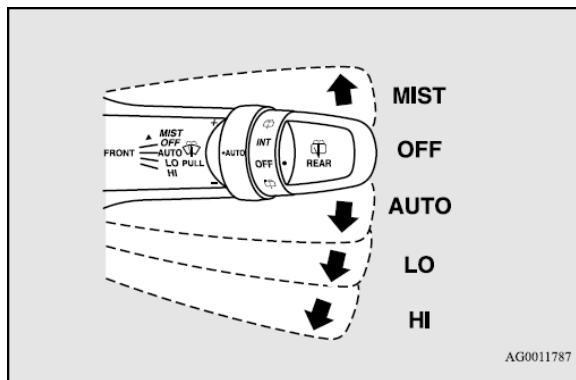

## PARTS INFORMATION

Part Number	Part Description
8250B137	WIPER MOTOR

## WARRANTY INFORMATION

#	Repair Procedure	Model Years	Campaign Operation	Labor Time Allowance	Part Number
1	Replace Windshield Wiper Motor	2007-2013	C1613S01	0.6 hours	8250B137

## WARRANTY / RECALL CAMPAIGN CLAIM INFORMATION

Enter all claims as claim type 'C' – Recall/Campaign Claims.

Please follow the campaign instructions when entering each claim in order to select the applicable operation code that correctly matches up with the work that was actually performed. A claim example is provided below.

### Certain 2007–2013 MY Outlander models

#### Claim Header Section:

**MITSUBISHI DEALER LINK** Service Warranty Help

Claim Entry Vehicle Information Interface PQR/VQR

### Campaign Information

Enter in the first 6 characters of the applicable campaign number: **C1613S.**

This campaign is for replacing the windshield wiper motor on all involved vehicles.  
Check the Open Campaign area of the Superscreen each time to be certain of a vehicle's eligibility. Only VINs showing **C1613S** as open are involved.  
Note: This recall was meant to be performed at the same time as C1613R–Wiper Link Replacement. Failure to perform C1613R and C1613S at the same time will prevent a dealer from being able to claim the correct amount of labor time needed to perform C1613R in the future.

Campaign Operation No: **C1613S**

Miles/Km: **64500**

VIN: **JA.....**

Service Technician: [ ] Emp N [ ] SERVICE ADVISOR [ ]

Spec Value \* [ ] Duplicate Recall \*

Dealer: 99320 Ref No: [ ] VIN: [ ]

Claim No: [ ] Adj: [ ] Claim Status: Incomplete Model and Year: [ ]

**Save & Continue** **Main Menu**

After entering the required customer data, vehicle information, select the applicable campaign number and the one replacement scenario performed. Then, by hitting the “Save and Continue” button, the system will automatically fill—in several fields. See the labor parts examples on the next page.

**Labor and Parts**

Labor: There is 1 repair scenario for this campaign – Replace the wiper motor.

Replace the windshield wiper motor: C1613S .6 hrs. labor

-----  
 Parts: Replace the windshield wiper motor.

Replace with part number: 8250B137 Wiper Motor Assembly

No other parts are required.

**Campaign Claim**

Follow the allowed labor time and required parts to be replaced depending on the one specific campaign operation that applies to the specific vehicle. The applicable campaign operation is shown on the Superscreen.

#	Repair Procedure	Model Years	Campaign Operation	Labor Time Allowance	Part Number
1	Replace Windshield Wiper Motor	2007–2013	C1613S01	0.6 hours	8250B137

**Rental Cars and/or Towing Charges:**

If there is a need to provide the owner with a rental car, claim the applicable charges in this section of the claim on the lower portion of the labor entry screen.

**Special Sublet Selection**

Select	Labor Operation	Labor Operation Description	
<input type="checkbox"/>	SHO	SPECIAL HANDLING ORDER	SHO Parts Order <input type="text"/>
<input type="checkbox"/>	RENTACAR	RENTAL CAR CHARGES 	Days <input type="text"/> Reason <input type="text" value="&lt;Select one&gt;"/> Rental Company <input type="text"/> Invoice Number <input type="text"/>
<input type="checkbox"/>	95300040	FREIGHT CHARGES	Freight Company <input type="text"/> Invoice Number <input type="text"/>
<input type="checkbox"/>	95200040	TOWING CHARGES	Towing Company <input type="text"/> Invoice Number <input type="text"/>



# IMPORTANT SAFETY RECALL

Mitsubishi Motors North America, Inc.

6400 Katella Avenue  
Cypress, CA 90630  
Telephone: 714-372-6000  
www.mitsubishicars.com

This notice applies to your vehicle, \_\_\_\_\_.

Date: July 2017

Dear FIRSTNAME LASTNAME,

This notice is sent to you in accordance with the National Traffic and Motor Vehicle Safety Act.

**Reason for notice:** Mitsubishi Motors North America, Inc. (MMNA) has decided that a defect which relates to motor vehicle safety exists in certain 2007 – 2013 Outlander vehicles. Water can potentially drop down onto the front wiper motor through a gap between the front deck garnish (the body piece between the hood and windshield) and the front windshield. If this occurs, water could potentially collect in the area of the wiper motor breathing hole. If the wiper motor is not operating, this water can then potentially enter the wiper motor through the breathing hole. If this occurs, such water intrusion over time may cause internal corrosion and/or electrical conduction failure resulting in non-operation of the windshield wiper motor.

If non-operation of the windshield wiper motor occurs, the windshield wipers will become inoperative which could reduce driver visibility under certain conditions and increase the risk of a vehicle crash.

In December 2016, you were also notified of a similar safety related defect involving the windshield wiper link rod. At that time, parts to provide a permanent remedy were not available. Those parts are now available. Accordingly, your local Authorized Mitsubishi Motors dealer can now repair your vehicle, both the windshield wiper motor and the wiper link rod, free of charge.

**What you should do:** Please contact your local Authorized Mitsubishi Motors dealer and schedule an appointment to have these recall remedies performed on your vehicle. When you bring your vehicle in, please show the dealer this letter. (If you misplace this letter, the dealer will still perform this repair to your vehicle, free of charge.)

**What your dealer will do:** The dealership will replace the wiper motor and wiper link rod with countermeasure parts.

**How long will it take?** The time needed for the replacement of the wiper motor and wiper link rod is **1 hour**. The dealer may need your vehicle for a longer period of time, but every effort will be made to minimize your inconvenience.

If you experience any problem having your vehicle repaired promptly and/or at no charge, please inform us by calling the Mitsubishi Customer Relations Department at **888-648-7820**. Hours: Monday through Friday 7 a.m. to 4 p.m. (Pacific Time).

If, after contacting Mitsubishi Customer Relations, you still have a problem getting this repair made promptly and/or without charge, write to the Administrator, National Highway Traffic Safety Administration, 1200 New Jersey Avenue SE, Washington, D.C. 20590, or call the toll-free Vehicle Safety Hotline at 1-888-327-4236 (TTY: 1-800-424-9153), or go to <http://www.safercar.gov>.

If you have already encountered a problem with the windshield wiper motor and/or wiper link rod, and had either repaired or replaced as a result of these specific conditions, and have paid for the repair(s), you may send your original repair order(s) or invoice(s), **and** original receipt(s)/proof of payment(s) to the following address for reimbursement consideration:

Mitsubishi Customer Relations Department, P.O. Box 6400, Cypress, CA 90630-0064

**If you are the lessor of this vehicle**, please forward a copy of this notice to the lessee within ten days to comply with federal regulations.

We appreciate your prompt attention to this matter.

Sincerely,

Mitsubishi Motors North America, Inc.

C1613R, C1613S