

<b>17V-399 Service Repair Procedure</b>		<b>17V-399</b>	
<b>BY:</b> Jose Vazquez	<b>DEPARTMENT:</b> Compliance	<b>DATE:</b> 06/08/2017	<b>REVISION:</b> A

**ISSUE:**

Trans Tech Bus vehicles equipped with Bus Air conditioning systems that utilize a 30AMP in-line fuse holder require the fuse holder to be upgraded. The concern is that in some cases the in-line fuse holder can overheat. In some cases the in-line fuses holder may be overloaded due to the addition of secondary equipment such as GPS and or communication systems.

**Models:**

Trans Tech Buses produced between 2011 and June of 2017, equipped with Bus Air , Air conditioning systems.

**TOOLS & REQUIRED COMPONENTS:**

1. Pin extractor
2. Screw driver set
3. Part# **500538**

**INSPECTION & CORRECTION:**

- a. Inspect the electrical compartment for an in-line fuse holder that has been mounted next to the circuit board , the fuse holder is secured with a #10 Philips screw that may come into contact with the 30amp fuse.  
*See images below*

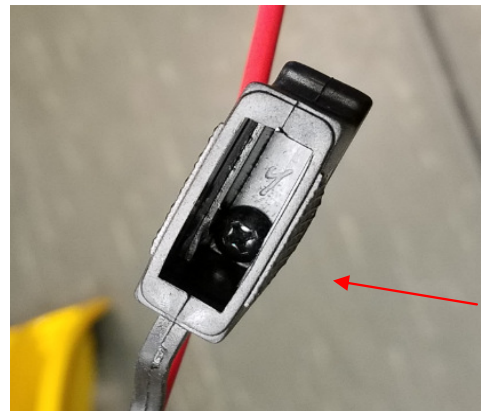
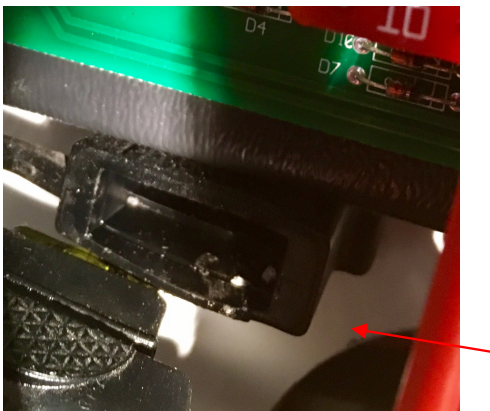

- The fuse holder should be removed and replaced with **Part# 500538**

<b>17V-399 Service Repair Procedure</b>		<b>17V-399</b>	
<b>BY:</b> Jose Vazquez	<b>DEPARTMENT:</b> Compliance	<b>DATE:</b> 06/08/2017	<b>REVISION:</b> A

**b.** The in-line fuse holder is being upgraded to an in-line mini fuse holder due to the potential for overheating. Verify that the fuse holder has a 30amp fuse, the minimum requirement is 30amp.

**c.** The current in-line fuse holder must be inspected for additional connections used for communication system and or GPS systems. The circuit is to solely be used for the A/C system.

**d.** It is also important that after accessing the vehicle circuit board the access panel be properly secured to separate the storage compartment from the electrical components as this may be unsafe if a driver stores paper goods in the compartment.

1. Make sure that vehicle is turned off and in the parked position.
2. Locate the circuit board above the driver’s seat, access the storage compartment and remove the access panel.
3. Identify the in-line fuse holder connected to **CN05** as shown in the schematic provided.
4. Disconnect the current inline fuse holder and install **Part# 500538**

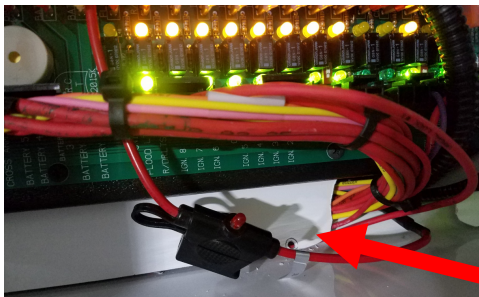

Image #1

Remove

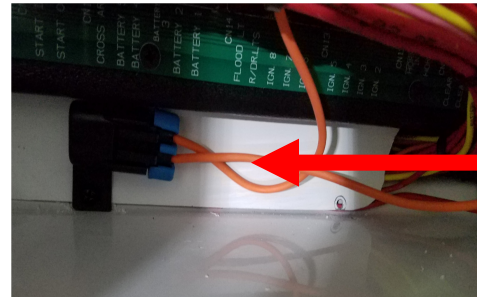

Image #2

Install part number 500538/ secure to bottom of panel



Image #2

Ensure that the electrical panel is reinstalled and secured

<b>17V-399 Service Repair Procedure</b>		<b>17V-399</b>	
<b>BY:</b> Jose Vazquez	<b>DEPARTMENT:</b> Compliance	<b>DATE:</b> 06/08/2017	<b>REVISION:</b> A

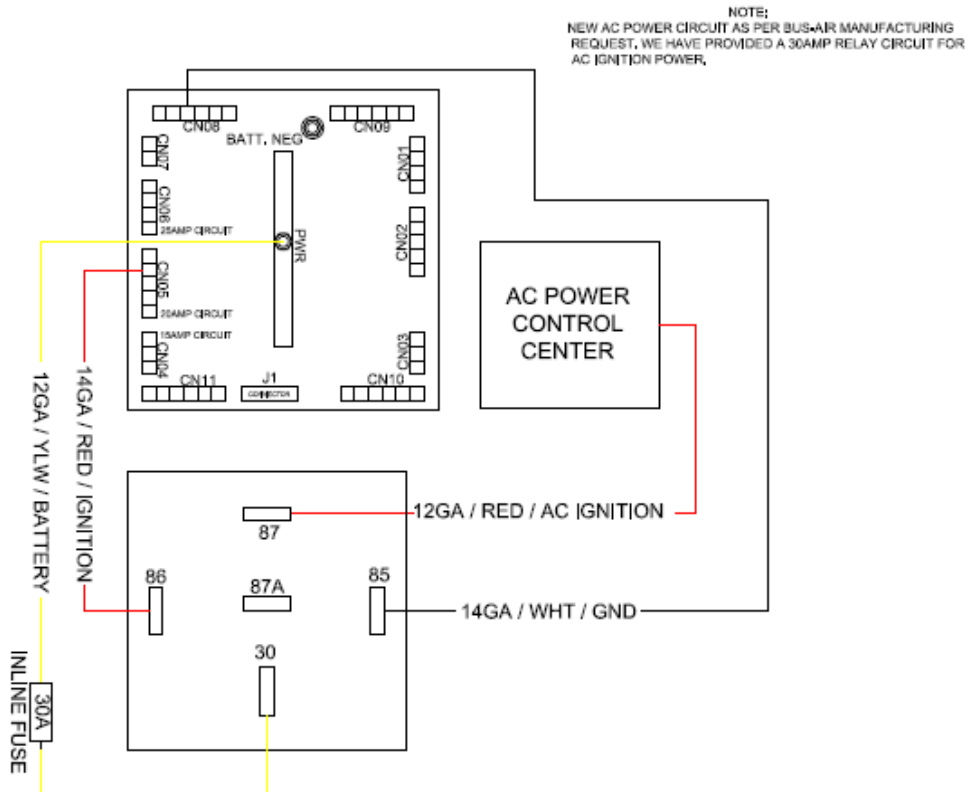

**REPAIR OPERATION TIME:** 0.20HOURS  
**TOTAL OPERATION TIME:** 0.20HOURS  
**WARRANTY STATUS:** FULLY WARRANTIED