



RECALL CAMPAIGN 17V-377: REPLACE ENGINE OIL COOLER LINE

New information provided by this revision is preceded by this symbol .

Please perform the procedure outlined in this Service Information on all affected vehicles before customer delivery. In the event the customer has already taken delivery of the vehicle, please perform the procedure the next time the vehicle is in the shop.

This Service Information bulletin replaces SI B17 04 17 **dated August 2017**.

What's New:

- Parts ordering procedure modified.

MODEL

G12 (7 Series M760i)

INFORMATION

Some of the vehicles involved in this Recall are also affected by the Service Action described in B41 02 17. If you have one of these vehicles then the repair described in this bulletin and the repair described in B41 02 17 can be performed at the same time to reduce repeat labor. The heat shield repair described in B41 02 17 includes removing the front engine cross member and this allows very easy access to the engine oil cooler line described in the procedure below. Review all opens campaigns for the vehicle before proceeding.

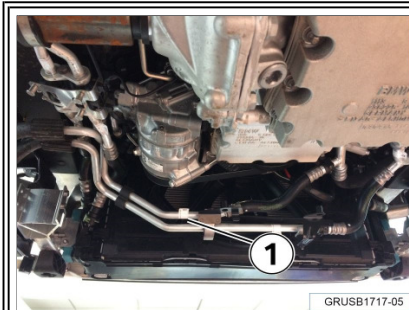

The engine oil cooler lines (1) are completely exposed once the engine cross member is removed from the vehicle. Do not remove the engine cross member unless the vehicle is also affected by the Service Action described in B41 02 17.

SITUATION

The left engine oil cooler supply line (feed line) was incorrectly manufactured.

Recall 17V-240 was announced for the replacement of this part, and following the discovery of an issue with the replacement hose, recall 17V-240 was stopped and closed.

In August 2017, a notification letter will be mailed to customers affected by this recall. As a courtesy, Customer Relations has already called all customers who had recall 17V-240 completed were previously affected by 17V-240 to explain why they will need to return to their BMW center to have their vehicle serviced for this repair the second time.

AFFECTED VEHICLES

This Recall Campaign involves G12 vehicles produced from October 2015 to June 2017.

Vehicles which require this Recall Campaign to be completed will show it as “Open” when checked either in AIR, the “Service Menu” of DCSnet (Dealer Communication System) or with the Key Reader.

CORRECTION

Replace the left engine oil cooler supply line (feed line).



PROCEDURE

1. Before ordering the parts the vehicle must be at the dealer and the vehicle key must be read in the Key Reader.
2. Submit a Parts Recall IDS Ticket.
3. When the parts are received, refer to the attached repair procedure until ISTA/D 4.06 is available.

When ISTA/D 4.06 is available refer to Repair Instruction **17 22 037 “Removing and installing/ replacing oil feed line for engine oil cooling (Engine oil cooler, left)”**.



PARTS INFORMATION

Before ordering any parts, read the above procedure. Only the oil line will be shipped on your behalf.

Check your inventory of the other part numbers listed below and only order if needed.

Refer to the ETK and the applicable repair instructions for one-time use fasteners and/or component information regarding additional or replacement screws, gaskets, and seals that need to be installed and claimed.

Part Number	Description	Quantity
17 22 7 952 927	Left engine oil cooler supply line (feed line).	1
31 10 6 870 648	Hex screw with washer	16
07 11 9 907 898	Hex screw	3
07 11 9 963 308	Sealing ring for oil drain plug	1
34 21 1 161 806	Hex screw brake disc	1
83 21 2 365 950	0W30 BMW engine oil – 1 liter	Up to 1 liter
or		
83 21 2 405 849	0W30 BMW engine oil – 209 liter drum	Up to 1 liter
or		
83 21 2 449 994	0W30 BMW engine oil – Tanker	Up to 1 liter

WARRANTY INFORMATION

Reimbursement for this Recall repair campaign for those vehicles can be submitted via normal claim entry utilizing the following information:

Vehicles receiving only the oil cooler supply line:

Defect Code:	0017780100	
---------------------	-------------------	--

Completion “before” vehicle delivery to the customer or the vehicle is already in the workshop

Labor Operation:	Labor Allowance:	Description:
00 65 588	13 FRU	Replace the left engine oil cooler supply line (feed line) (Plus work)

Or:

Completion after vehicle delivery to the customer

Labor Operation:	Labor Allowance:	Description:
00 65 054	15 FRU	Replace the left engine oil cooler supply line (feed line) (Main work)

And:

Sublet – Bulk Materials

Sublet Code 4	See sublet reimbursement calculation below	Reimbursement for the repair-related bulk materials (BMW part number(s), please do not use the part numbers for claim submission)
----------------------	--	---

Or, with:

[SI B41 02 17: Vehicles receiving oil supply cooler line and the heat shield](#)

UPDATE! The labor operations listed on B41 02 17 **includes** additional time for installing the oil supply cooler line and heat shield.

Claim work time labor operation “17 99 000 for 1 FRU” to clear this “oil line” Recall campaign **in conjunction** with performing the repair outlined in SI B41 02 17

Defect Code:	0017780100	
Labor Operation:	Labor Allowance:	Description:
17 99 000	1 FRU	Clearing this oil line Recall campaign in conjunction with performing the repair outlined in SI B41 02 17 (Plus work)

And, as applicable:

Alternative Mobility Solutions (AMS) Reimbursement

This recall repair qualifies for Alternative Mobility Solution (AMS) expense reimbursement, please claim this under the Defect Code noted above as follows:

--	--	--

Sublet Code “2”	See below	Alternative Mobility Solution (AMS) expense reimbursement
------------------------	-----------	---

Claimable AMS-related reimbursement items and allowances (at cost, no markup)

- Mass transit (Up to \$15.00);
- Taxi and livery services (Up to \$15.00);
- “On-demand” Phone app-based transportation services (Up to \$15.00); or
- Vehicle pickup/drop off service “to and/or from” a customer’s home or business location (Up to \$25.00).

Please refer to SI B01 29 16 for additional information. Itemize this sublet amount on the repair order and in the claim comment section.

CUSTOMER SATISFACTION SUPPORT — BMW EMPOWER Program

BMW strives to provide the Ultimate Service Experience to complement the Ultimate Driving Machine. Your efforts are sometimes challenged by situations that are beyond the center’s control. We understand you may have customers;

- Waiting on a Vehicle Delivery due to this recall

Or:

- Already in a vehicle affected by this recall.

For these customers we ask that you wow them by using BMW EMPOWER explained in SI B01 14 15. We should show our customers how much we appreciate them with a surprise and delight gesture.

Aftersales Area Manager (AAM) “Field Authorization” (FAS) is not required.

Let’s show our customers just how much we appreciate them for being part of the BMW family.

Friday, September 1, 2017

ATTACHMENTS

View PDF attachment [B170417 N74 Q and A](#).

View PDF attachment [B17 04 17 Instructions](#).

[Copyright ©2017 BMW of North America, Inc.]

17 22 037 Removing and installing/replacing oil feed line for engine oil cooling (branch - engine oil cooler, left)

Overview of activities

Additional information

Preliminary work

- 1 Opening up the acoustic cover
- 2 Opening the oil filler cap
- 3 Releasing the oil drain plug
- 4 Removing the front underbody protection
- 5 Removing the front stiffening plate
- 6 Removing the wheel
- 7 Removing the brake air duct
- 8 Removing the front wheel arch cover

Main Work



- 9 Removing the oil feed line and the left oil return line
- 10 Installing the oil feed line and the left oil return line

Follow-up Work

- 11 Installing the front wheel arch cover
- 12 Installing the brake air duct
- 13 Mounting the wheel
- 14 Installing the front stiffening plate
- 15 Installing front underbody protection
- 16 Tightening the oil drain plug
- 17 Filling up engine oil
- 18 Closing the oil filler cap
- 19 Closing up the acoustic cover
- 20 Checking the oil level

General information

⚠ WARNING

Slipping of the vehicle from the vehicle lift if the vehicle lift is improperly used.

Danger of life-threatening injuries!

- Observe the safety information for lifting the vehicle with a vehicle lift.
- For further information see: 00 ... Lifting the vehicle with a vehicle lift.

⚠ WARNING

Hot fluids.

Risk of scalding!

- Work on the vehicle only with appropriate personal protective equipment.

⚠ CAUTION

Harmful substances.

Contact with liquids is hazardous to health!

- Note and observe the safety information on the containers.
- Work only with appropriate personal protective equipment.

i TECHNICAL INFORMATION

Catch and dispose of escaping fluids. Observe country-specific waste disposal regulations.

PRELIMINARY WORK

1–Opening up the acoustic cover

👉 RISK OF DAMAGE

Damage to the acoustic cover.

Jerky pulling during the disassembly as well as great use of force during installation can lead to breakage of the acoustic cover.

- Carefully disassemble or mount the acoustic cover.
- Disassemble or mount snap-lock couplings one after the other from the ball studs.
- Disassemble or mount the acoustic cover only at temperatures > 20 °C.
- Only use distilled water as an aid during installation; no lubricants.



- Open up the acoustic cover in the direction of arrow.

2–Opening the oil filler cap



- Open the oil filler cap (1).

3–Releasing the oil drain plug

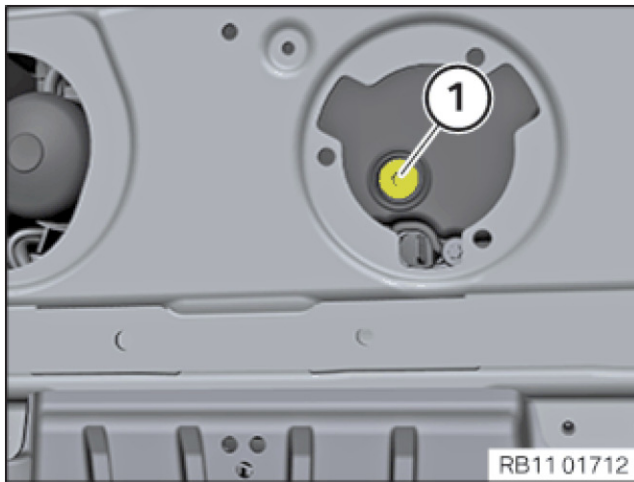

i TECHNICAL INFORMATION

Catch and dispose of escaping fluids. Observe country-specific waste disposal regulations.

- Release the oil drain plug (1) from the oil sump.
- Drain the engine oil.

4–Removing the front underbody protection

NOTE

For a better overview: schematic diagram with partially hidden components.

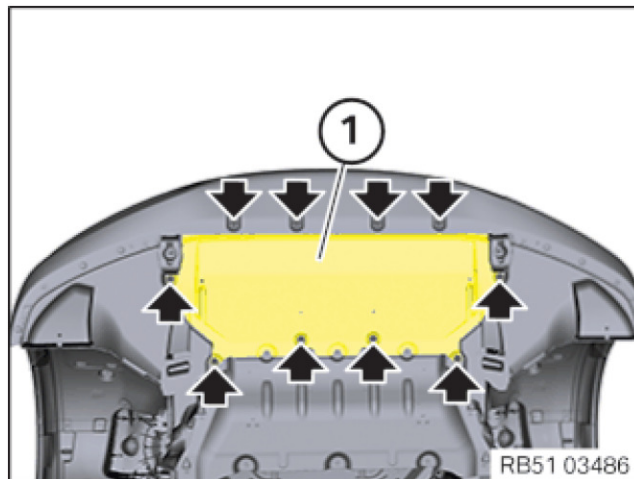

- Release screws (arrows).
- Pull out the front underbody protection (1).

► **If installed: remove the front stiffening plate**

▷ **Removing the front stiffening plate**

i TECHNICAL INFORMATION

Driving without stiffening plate is not permitted.

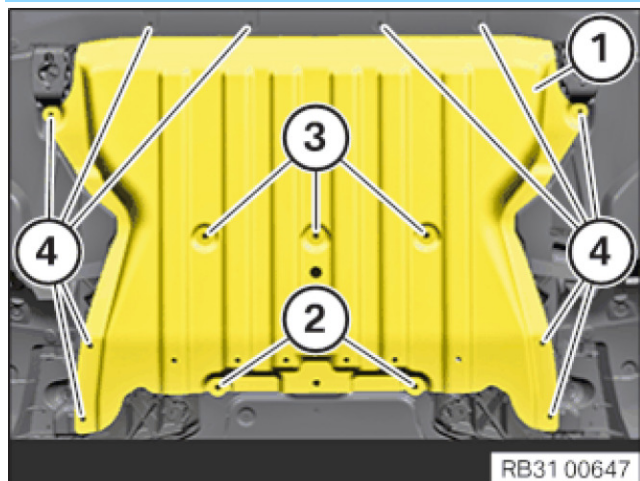

- Release screws (2) to (4).
- Take off stiffening plate (1).

5-Removing the front stiffening plate

i TECHNICAL INFORMATION

Driving without stiffening plate is not permitted.

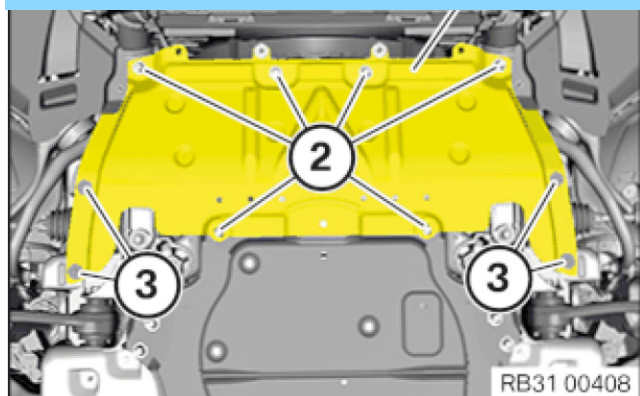

- Release screws (3).
- Release screws (2).
- Take off the front stiffening plate (1).

6–Removing the wheel



- In case more than one wheel is to be removed at the same time: Use chalk on each tyre to mark from which axle and from which side the wheel was located.
- Release the wheel bolts and take off the wheel.

To release and tighten the wheel bolts with the safety code, the correct adapter must be used from the tool set **0 492 518 (36 1 300)** (wheel bolt adapter set).

7–Removing the brake air duct

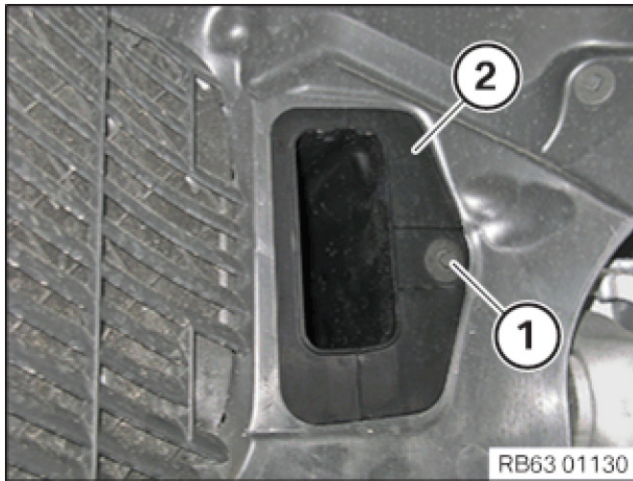

- Release the screw (1) and pull the brake air duct (2) out of the wheel arch cover.

8–Removing the front wheel arch cover

NOTE

For a better overview: schematic diagram with partially hidden components.

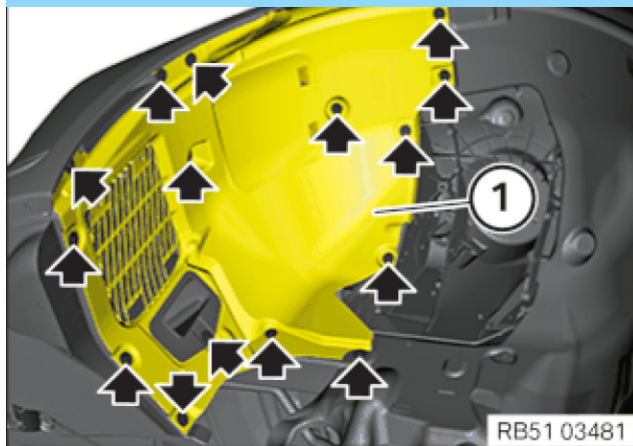

- Release screws (arrows).
- Pull out the front wheel arch cover (1).

MAIN WORK

9–Removing the oil feed line and the left oil return line

⚠ WARNING

Hot fluids.

Risk of scalding!

- Work on the vehicle only with appropriate personal protective equipment.

⚠ CAUTION

Harmful substances.

Contact with liquids is hazardous to health!

- Note and observe the safety information on the containers.
- Work only with appropriate personal protective equipment.

i TECHNICAL INFORMATION

Catch and dispose of escaping fluids. Observe country-specific waste disposal regulations.

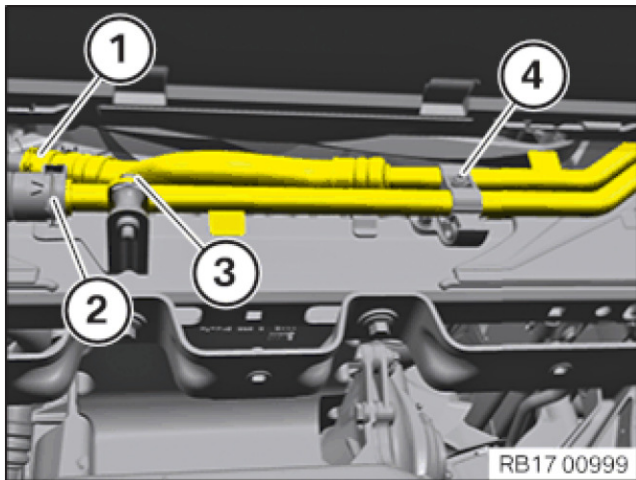

- Unlock and pull off the oil feed line (1) at the separation point.
- Unlock and pull off the oil return line (2) at the separation point.
- Catch and dispose of escaping engine oil.
- Release the nut (3).
- Release the screw (4) and remove the holder.
- Uncover oil feed line and oil return line.

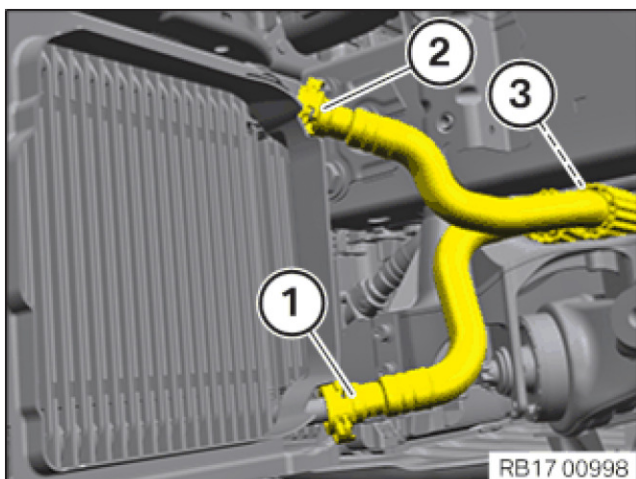

- Unlock and pull off the oil return line (1) from the left engine oil cooler.
- Unlock and pull off the oil feed line (2) from the left engine oil cooler.
- Lead the oil feed line and oil return line between the side member and the front axle support (3) and remove.

10-Installing the oil feed line and the left oil return line

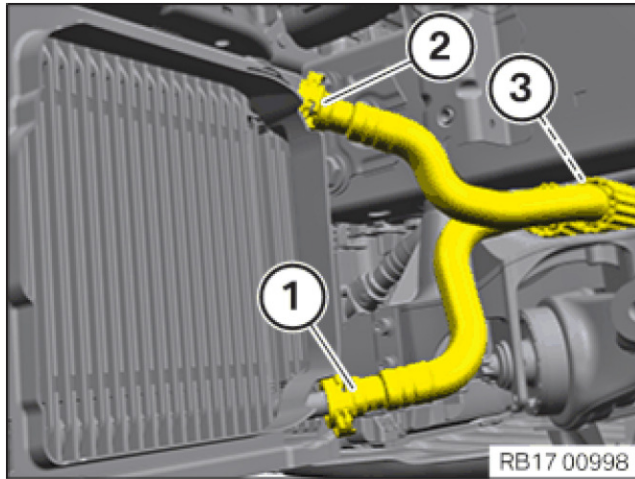

- Lead the oil feed line and oil return line between the side member and the front axle support (3) and place.
- Connect the oil return line (1) to the left engine oil cooler and audibly engage it.
- Connect the oil feed line (2) to the left engine oil cooler and audibly engage it.

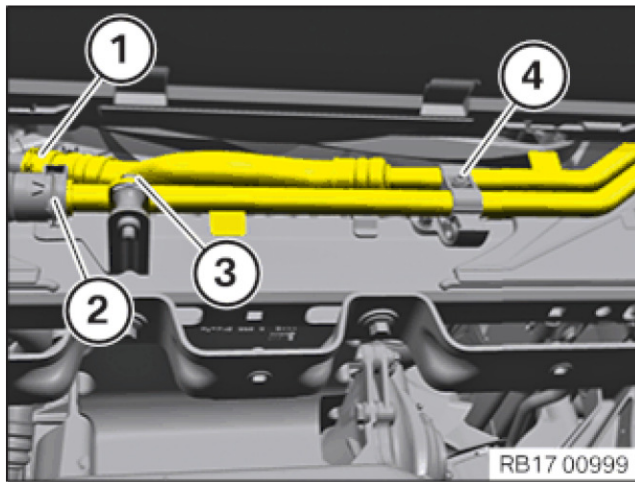

- Lay the oil feed line and oil return line and mount it to the holder.
- Connect the oil feed line (1) to the separation point and engage it audibly.
- Connect the oil return line (2) to the separation point and engage it audibly.
- Tighten the nut (3).

Oil feed line/oil return line at the holder at the front axle support



M6 nut		8 Nm
--------	--	------

- Mount the holder and tighten the screw (4).

Oil feed line/oil return line at the holder at the front axle support



Oval-head screw		5 Nm
-----------------	--	------

FOLLOW-UP WORK

11–Installing the front wheel arch cover

NOTE

For a better overview: schematic diagram with partially hidden components.

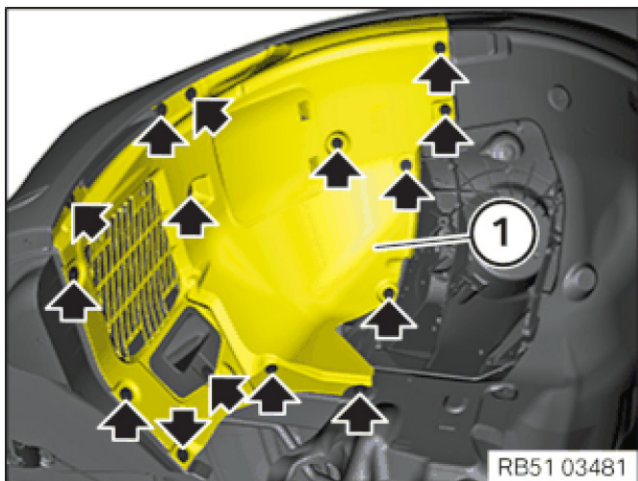

- Insert the front wheel arch cover (1).
- Tighten the screws (arrows).

Wheel arch cover

Screw		3 Nm
Plastic nut		2.6 Nm

12–Installing the brake air duct

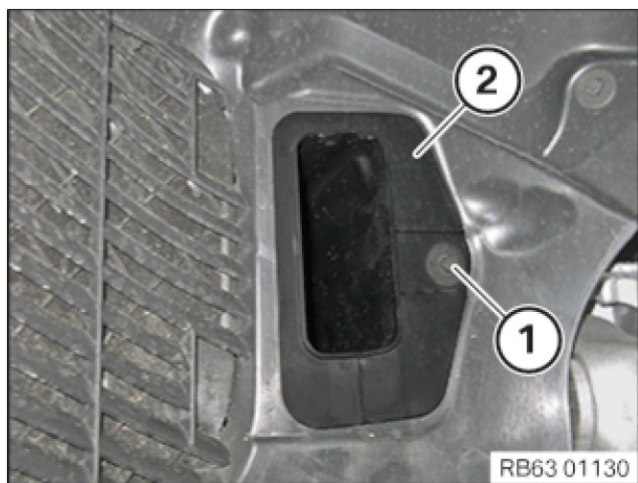

- Insert the brake air duct (2) in the wheel arch cover.
- Tighten the screw (1).

Wheel arch cover

Screw		3 Nm
Plastic nut		2.6 Nm

13–Mounting the wheel

- **Cleaning the contact surface between the brake disc and the wheel rim**

TECHNICAL INFORMATION

The contact surface between the brake disc and the wheel rim must be clean and free of oil and grease. Otherwise there is a danger that the wheel will loosen later.

- Free the contact surface with a drill and the special tool **2 344 011** from dirt, grease residue and corrosion.

The special tool **2 344 011** may not be operated with an impact screwdriver.

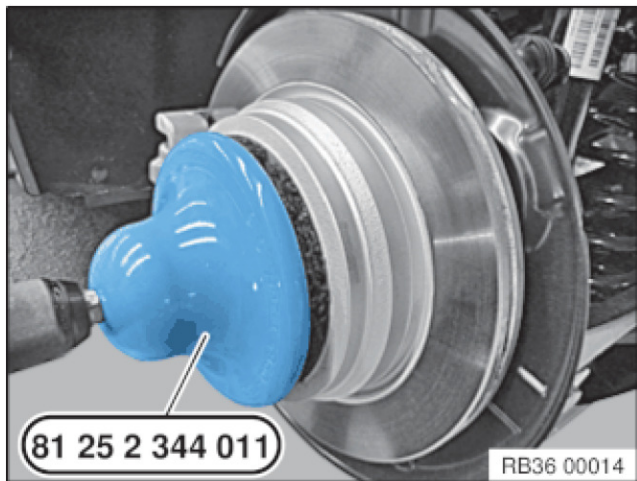

- Degrease the contact surface with universal cleaner (see BMW Group Parts).
- If there is grease residue near the area of the wheel bolt holes, remove and clean the brake disc.

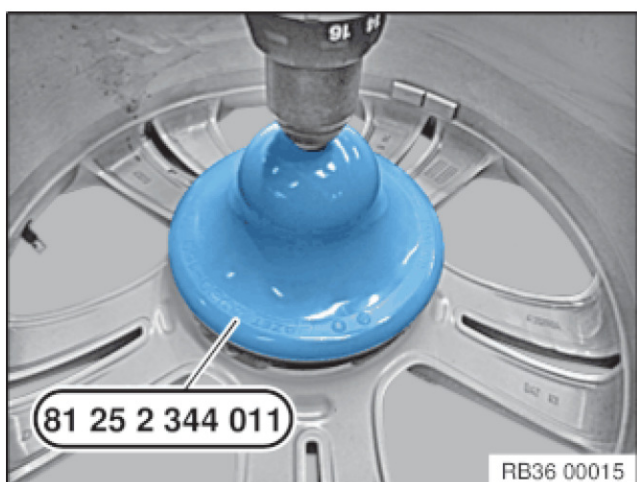

- Free the contact surface with a drill and the special tool **2 344 011** from dirt, grease residue and corrosion.

The special tool **2 344 011** may not be operated with an impact screwdriver.

- Degrease the contact surface with universal cleaner (see BMW Group Parts).

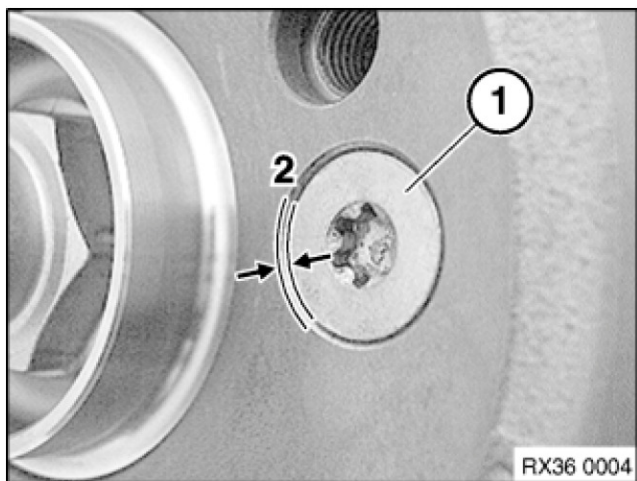

- Check that mounting bolt for the brake disc (1) is firmly seated.

The mounting bolt for the brake disc (1) must never protrude on the contact surface (2) between the brake disk and the rim.

Brake disc on front wheel hub



M8	Renew the screw.	Tightening torque	16 Nm
----	------------------	-------------------	-------

Brake disc on rear wheel hub



M8	Renew the screw.	Tightening torque	16 Nm
----	------------------	-------------------	-------



- Thinly grease the wheel centring (1) in the wheel rim; see further information for more about the grease for wheel centring.



i TECHNICAL INFORMATION

Impact or electric screwdrivers must not be used to screw in and tighten the wheel bolts.

The wheel rim must be distributed evenly on the brake disc.

In the case of non-original BMW wheel bolts/rims, it may be necessary to tighten the wheel bolts setting properties (please observe documentation from the manufacturer).

New wheel bolts must not be oiled.

- Renew corroded wheel bolts.

Parts: Wheel bolts

- Clean wheel bolts.
- Check the wheel bolts and the thread for damage; if need be, renew the wheel bolts.
- Apply and tighten the wheel bolts (arrows).

Wheel bolts



M 14 / S W 17			
		Screw in the wheel bolts and manually tighten them crosswise to centre the wheel rim.	
		Tighten the wheel bolts crosswise with a calibrated torque wrench to the specified tightening torque.	140 Nm
		- Check all wheel bolts in the same sequence or re-tighten them to the specified tightening torque.	
			140 Nm

14-Installing the front stiffening plate

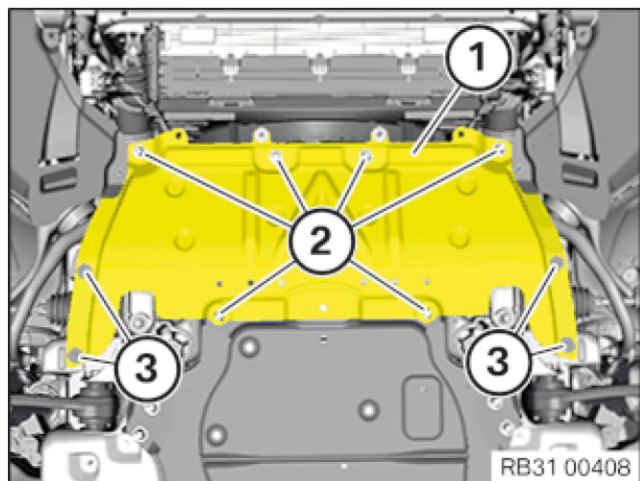

- Renew the screws (2).

Parts: Screws

- Position stiffening plate (1).
- Tighten the screws (2).

Stiffening plate at the front axle support



M8	Renew screws.	Jointing torque	15 Nm
		Angle of rotation	90°

Stiffening plate at the front axle support



M8	Renew screws.	Jointing torque	25 Nm
		Angle of rotation	70°

- Tighten the screws (3).

Cover, steering assembly



Screw		Tightening torque	3 Nm
-------	--	-------------------	------

15-Installing front underbody protection

NOTE

For a better overview: schematic diagram with partially hidden components.

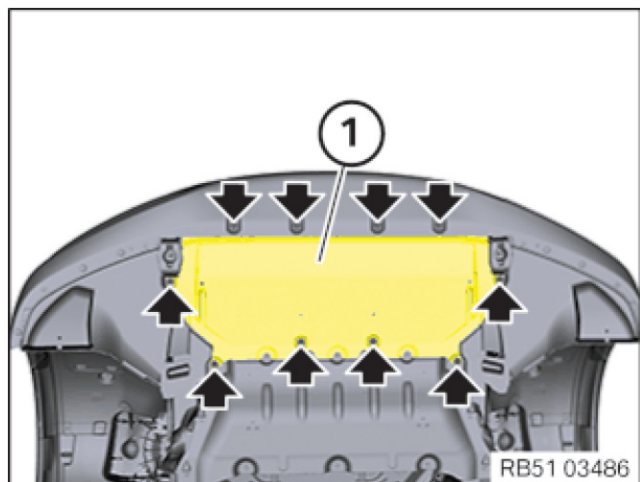

- Insert the front underbody protection (1).
- Tighten the screws (arrows).

Underbody protection

Screw		Tightening torque	3 Nm
-------	--	-------------------	------

► **If installed: Install the front stiffening plate**

▷ **Install the front stiffening plate**

TECHNICAL INFORMATION

Driving without stiffening plate is not permitted.

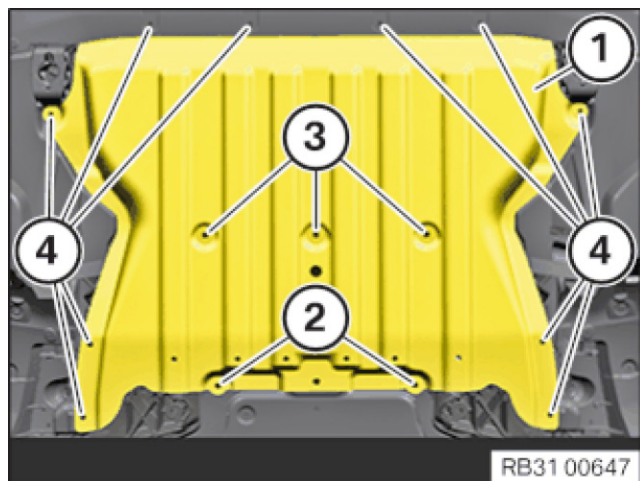

- Renew the screws (2).
- Position stiffening plate (1).
- Tighten the screws (2).

Parts: Screws

Stiffening plate at the front axle support

M8	Renew screws.	Jointing torque	15 Nm
		Angle of rotation	90°

Stiffening plate at the front axle support

M8	Renew screws.	Jointing torque	25 Nm
		Angle of rotation	70°

- Tighten the screws (3).

Stiffening plate at the holder

M6			8 Nm
----	--	--	------

- Tighten the screws (4).

Underbody protection



Screw		Tightening torque	3 Nm
-------	--	-------------------	------



16–Tightening the oil drain plug

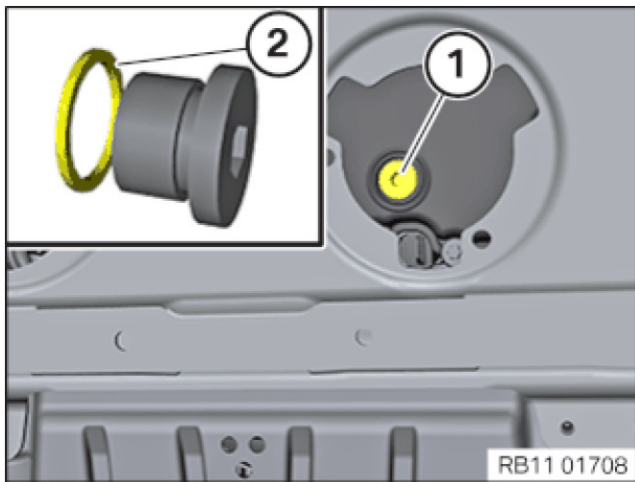

- Renew the sealing ring (2).
- Position the oil drain plug (1) at the oil sump and tighten.

Oil drain plug



M12x1.5	Renew the sealing ring		20 Nm
---------	------------------------	--	-------

Oil drain plug



M18x1.5	Renew the sealing ring.		40 Nm
---------	-------------------------	--	-------

17–Filling up engine oil

RISK OF DAMAGE

Engine damage due to overfilling with engine oil.

Overfilling with engine oil can lead to engine damage.

- Pay attention to the exact capacity of the engine oil.
- Allow engine oil to drain.

- Fill the engine oil in the oil filler neck (arrow).

Engine oil



Capacity, engine oil change with oil filter element		12.0 l
---	--	--------

Engine oil: [see approved engine oils for BMW Group engines](#)



18–Closing the oil filler cap



- Close the oil filler cap (1).

19–Closing up the acoustic cover

RISK OF DAMAGE

Damage to the acoustic cover.

Jerky pulling during the disassembly as well as great use of force during installation can lead to breakage of the acoustic cover.

- Carefully disassemble or mount the acoustic cover.
- Disassemble or mount snap-lock couplings one after the other from the ball studs.
- Disassemble or mount the acoustic cover only at temperatures $> 20\text{ }^{\circ}\text{C}$.
- Only use distilled water as an aid during installation; no lubricants.



- Close up the acoustic cover in the direction of arrow and clip in using light pressure.

20–Checking the oil level

- Place the motor vehicle on a horizontal surface.
- Read off the oil level in the instrument cluster (KOMBI) or at the control display.
- If need be, top up engine oil.

**Engine Oil Cooler Line
Safety Recall 17V-377
Model Year 2017-2018
BMW 7 Series (12-cylinder)
*Last Updated 07/13/2017***

Q1. Which BMW Group models in the US are potentially affected by this Safety Recall?

Approximately 280 Model Year 2017-2018 BMW 7 Series (12-cylinder) vehicles in the US, produced between May 2016 and June 2017, are potentially affected.

Q2. What is the specific issue?

Affected vehicles were equipped with an incorrect engine cooler line.

Q3. What can happen as a result of this issue?

This issue could result in an oil leak. Depending upon the location and size of the leak, this could increase the risk of a crash. Other road users could also be affected by the oil leak.

Q4. How did BMW Group become aware of this issue?

BMW Group became aware of this issue through its quality control procedures.

Q5. Why are other BMW Group vehicles not included in this Safety Recall?

Other vehicles were manufactured with oil cooler lines produced to specifications by the supplier.

Q6. Can I determine if this issue exists in my vehicle?

No.

Q7. Can I continue to drive my vehicle?

Yes. However, when you receive a letter asking you to have this recall performed by an authorized BMW center, please do so as soon as possible. If you are not the only driver of this vehicle, please advise all other drivers of this important information.

Q8. How will my vehicle be repaired?

The oil cooler line will be replaced.

Q9. Is BMW Group aware of any accidents, injuries, or fires involving these BMW Group vehicles associated with this Safety Recall?

No.

Q10. How will I be informed of this Safety Recall?

You will receive a letter in August via First Class mail advising you of this recall. At that time, you should immediately schedule an appointment with an authorized BMW center to have this recall performed. You can locate your nearest authorized BMW center at www.bmwusa.com/dealers.

**Engine Oil Cooler Line
Safety Recall 17V-377
Model Year 2017-2018
BMW 7 Series (12-cylinder)
*Last Updated 07/13/2017***

To ensure BMW has your most recent contact and vehicle information, please register your vehicle at www.bmwusa.com/myBMW. Registration is free, and will give you access to factory initiated campaigns and other information specific to your BMW.

Q11. How long will the repair take?

This repair may take several hours; however, additional time may be required depending upon your BMW center's schedule. The repair will be performed free of charge by your authorized BMW center.

Q12. Do I have to wait for my letter in order to have my vehicle serviced?

No. You can schedule an appointment with any authorized BMW dealer for service and repair.