

AH08 - Replacing Fastening Screws for Camshaft Controllers (Recall Campaign)

Vehicle Type: **Panamera S (970)/Panamera 4S (970)
Panamera Turbo (970)/Panamera Turbo S (970)**

Model Year: **As of 2010 up to 2012**

Country/market:

- USA
- Canada

Subject: **Fastening screws for camshaft controllers**

Information: **Due to influencing factors during the camshaft controller assembly process, the threaded connections can become strained to such an extent that the function of the camshaft controller cannot be guaranteed over the service life of the vehicle.**

Remedial action:

- Replace fastening screws for camshaft controllers.
- Also replace one or both camshaft controllers if necessary.



Information

If you see from the vehicle's workshop history, for example, that **both** camshaft controllers on the vehicle were already replaced by components with Part No. **948.105.051.22** or a higher index before carrying out the campaign, the fastening screws **must not be replaced**.

- The campaign must not therefore be carried out on the vehicle.
- This must be documented accordingly in PQIS. The campaign must be marked as **cannot be carried out** with the reason **"Campaign scope already carried out on the vehicle prior to starting the campaign"**. The **"Warranty relevance"** flag must be activated in order to be able to set a warranty claim and close the campaign.
- A warranty claim must be submitted for the campaign in which **0 TU** is entered as the specified **working time** and **no** material items are specified.

Affected Vehicles: Only the vehicles assigned to the campaign (see also PIWIS Vehicle information). This recall campaign affects 19,809 vehicles in North America.

Installation position:



Information

The following illustrations in this document show the V8 Turbo engine as an example. The position of the individual components and the procedure for the V8 naturally aspirated engine are identical to the description provided here.

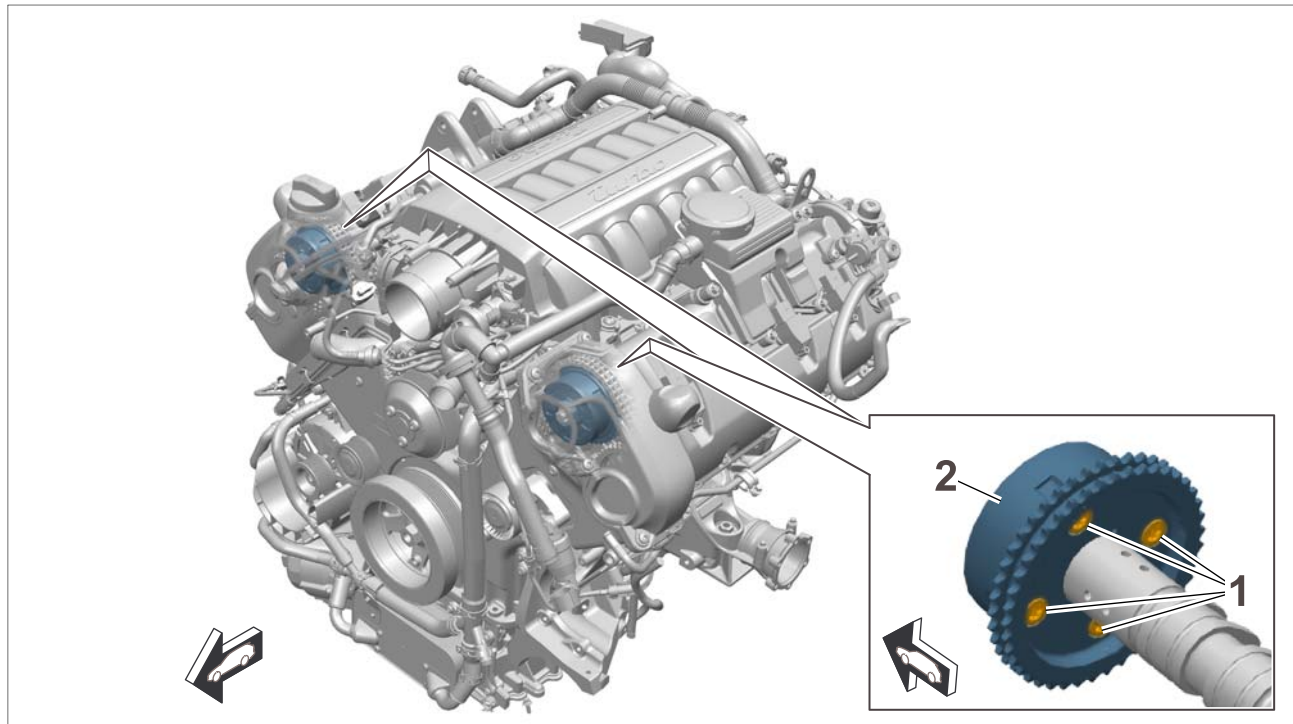

Overview of threaded joint for camshaft controllers

- 1 – Fastening screws on camshaft controllers (**replace**)
- 2 – Camshaft controllers for intake camshafts

Required parts and materials

Important:

Ordering Required Parts:

Parts for this campaign will be automatically allocated for up to 50% of the vehicles that are serviced at your dealership.

IF CAMSHAFT CONTROLLER (PART NUMBER - 94810505123) IS REQUIRED, PLEASE ORDER VIA PTEC/PAV.

Parts Info:

Part No.	Designation – Use	Qty.
99906780330	⇒ Cheese head bolt, M7 x 21 – Camshaft controller	8 ea.
94810514600	⇒ Hexagon round-head bolt – Ignition rod modules	8 ea.
94810743720	⇒ Seal – Oil mist separator	1 ea.

94810743820	⇒ Seal – Oil mist separator	1 ea.
94810593501	⇒ Seal for cyl. 1-4 – Cylinder head cover, left	1 ea.
94810593601	⇒ Seal for cyl. 5-8 – Cylinder head cover, right	1 ea.
94810593702	⇒ Inner seal – Cylinder head cover, left/right	8 ea.
94810593800	⇒ Seal for actuator – Cylinder head cover, left/right	2 ea.
99907390531	⇒ Oval-head screw, M6 x 30 – Cylinder head cover, left/right	23 ea.
99907390831	⇒ Oval-head screw, M8 x 35 – Cylinder head cover, left/right	3 ea.
WHT005204	⇒ Cheese head bolt, M10 x 80 – Torque support to spring strut dome	1 ea.
WHT004595	⇒ Cheese head bolt, M10 x 90 – Torque support to cylinder head cover	1 ea.
WHT004635	⇒ Hexagon nut, M10 – Torque support	2 ea.
99907391431	⇒ Oval-head screw, M6 x 55 – Secondary-air pump to cylinder head cover	2 ea.
99907390231	⇒ Oval-head screw, M6 x 16 – Holder for wire harness to cylinder head cover	2 ea.

Materials: **Required materials** (usually already available in the Porsche dealership):

Part No.	Designation – Use	Qty.
00004330547	⇒ Drei Bond sealing compound Silikon 2210 – Cylinder head cover	30g tube As much as required (approx. 10 grams required per vehicle)
00004330515	⇒ Antifreeze – Cooling system	1-liter container As much as required (approx. 500 ml required per vehicle)

Required tools

- Tools:
- Tamper Proof Torx socket-wrench insert T45 > Torx socket-wrench insert **-1-** with a length > Torx socketwrench insert **-A-** of approx. 125 mm for the threaded joint on the camshaft controllers, e.g. Hazet socket-wrench insert 992SLG-T45

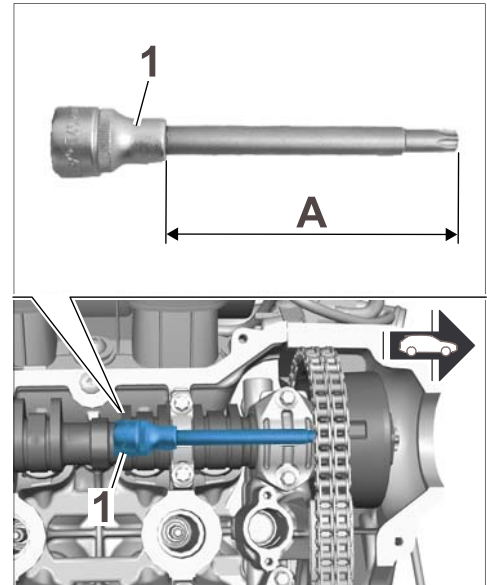

Torx socket-wrench insert, long

- **9768 - Electronic torque wrench, 2 - 100 Nm (1.5 - 74 ftlb.)**
- Torque wrench, 2 – 10 Nm (1.5 – 7.5 ftlb.), e.g. **V.A.G 1783 - Torque wrench, 2-10 Nm (1.5-7.5 ftlb.)**
- Torque wrench 6 – 50 Nm (4.5 – 37 ftlb.), e.g. **V.A.G 1331 - Torque wrench, 6-50 Nm/4.5-37 ftlb.**
- **VAS 6935 - Pole terminal puller**
- **3122 B - Spark plug wrench**
- **9701 - Assembly sleeve**
- **9714 - Socket-wrench insert**
- **9824 - Flexible-head socket wrench, a/f 8**
- **9824/1 - Flexible-head socket wrench, a/f 10**
- **9824/2 - Torx Micro Bit T30**
- **9824/3 - Torx Micro Bit T45**
- Hose clamps, e.g. **3093 - hose clamp** or **3094 - hose clamp**
- Water-resistant marker for marking the threaded joint on the camshaft controllers

Preparatory work

Work
Procedure:



Information

Depending on vehicle equipment, it may be necessary to **disconnect individual lines** in order to **access** the fastening screws for the **cylinder head cover**.

There is **no** need to **remove** any other **components** (e.g. coolant reservoir or hydraulic unit). The specified **working time** already **includes the time required** for **partially loosening** the lines.

- 1 Move front lid into service position ⇒ *Workshop Manual '552213 Securing lid (service position)'*.
- 2 Remove both wiper arms ⇒ *Workshop Manual '922519 Removing and installing wiper arm'*.
- 3 Remove plenum panel cover at the left and right ⇒ *Workshop Manual '852219 Removing and installing plenum panel cover'*.
- 4 Remove rear profile seal for front hood ⇒ *Workshop Manual '553319 Removing and installing front lid seal'*.
- 5 Remove cowl panel cover ⇒ *Workshop Manual '508719 Removing and installing cowl panel cover'*.
- 6 Remove wiper linkage ⇒ *Workshop Manual '921919 Removing and installing wiper linkage'*.
- 7 Remove cross panel for engine compartment ⇒ *Workshop Manual '508119 Removing and installing cross panel (disassembling plenum panel)'*.
- 8 Remove torque support ⇒ *Workshop Manual '103719 Removing and installing torque support'*.
- 9 Remove secondary-air pump ⇒ *Workshop Manual '266519 Removing and installing secondary-air pump with bracket'*.
- 10 Remove engine cover on both cylinder banks ⇒ *Workshop Manual '108319 Removing and installing engine cover (design cover)'*.
- 11 Remove bar ignition modules on both cylinder banks ⇒ *Workshop Manual '282020 Removing and installing bar ignition modules'*.
- 12 Remove oil mist separator on cylinder bank 5-8 ⇒ *Workshop Manual '105519 Removing and installing oil mist separator'*.



Information

The **space available** for loosening and tightening the **fastening screws for the cylinder head cover** may be **restricted depending on vehicle equipment**.

Always **use the tools recommended** in the Workshop Manual for carrying out repairs.

- 13 Remove cylinder head covers on both cylinder banks ⇒ *Workshop Manual '158219 Removing and installing cylinder head cover'*.
- 14 Remove spark plugs on both cylinder banks ⇒ *Workshop Manual '287020 Removing and installing spark plugs'*.

Replacing fastening screws for camshaft controllers

Work

Procedure:

NOTICE

Loosening several fastening screws on the camshaft controller at the same time

- Damage to the camshaft controller
- Adjustment of valve timing for camshaft drive
- Damage to the valve drive

⇒ Replace fastening screws for the camshaft controller individually, one at a time

- 1 Replace fastening screws ⇒ *Fastening screws for camshaft controller on cyl. 1-4 -1-* for the camshaft controller on cylinder bank 1-4 ⇒ *Fastening screws for camshaft controller on cyl. 1-4 -2-*.

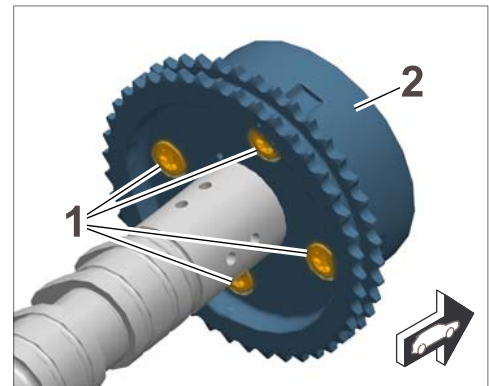

Fastening screws for camshaft controller on cyl. 1-4

- 1.1 Use the tool **9714 - socket-wrench insert** to turn the engine at the vibration balancer in rolling direction until one of the fastening screws ⇒ *Turning engine to assembly position, cyl. 1-4-1-* for the camshaft controller ⇒ *Turning engine to assembly position, cyl. 1-4-2-* on cylinder bank 1–4 is at the same height as the flattened area on the mounting saddle for the intake camshaft.

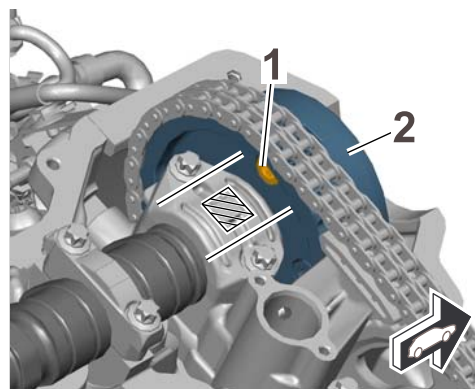

Turning engine to assembly position, cyl. 1-4



Information

For easy access and to prevent damage to the cylinder head or valve drive, the threaded joint on the camshaft controllers must be loosened and tightened using the prescribed Torx socket-wrench insert. The use of this Torx socket-wrench insert ensures that the tool can be fitted correctly on the screw heads.

- 1.2 Cover the contact surface ⇒ *Covering contact surface -A-* on the camshaft with adhesive tape or a clean, lint-free cloth to prevent damage to the camshaft when replacing the fastening screws using the Torx socket-wrench insert ⇒ *Covering contact surface -1-*.

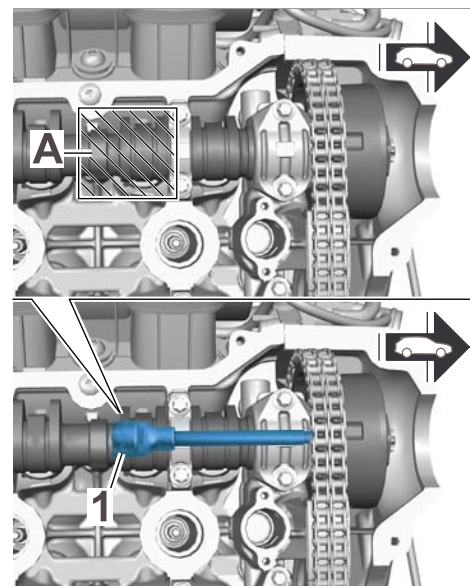

Covering contact surface

- 1.3 Unscrew and remove fastening screw ⇒ *Replacing fastening screw on cyl. 1-4-1-* for the camshaft controller ⇒ *Replacing fastening screw on cyl. 1-4-2-* using the prescribed Torx socket-wrench insert.



Information

If **one or more fastening screws** for the camshaft controller have **already become loose** and can be **unscrewed and removed by hand**, the **camshaft controller must be replaced**.

In this case, first replace the **fastening screws for the camshaft controller for cylinder bank 5-8** as described in Step 2 and then replace the affected camshaft controller ⇒ *Technical Information 'AH0800 Replacing camshaft controller'*.

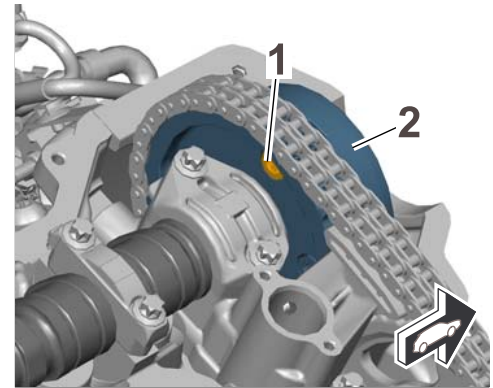

Replacing fastening screw on cyl. 1-4

NOTICE

Improper handling of the camshaft controller

- **Damage to the camshaft controller**
- ⇒ **Do not use any degreasing liquid cleaning agents.**
- ⇒ **Clean the threaded bore and contact surface of the camshaft controller only using a clean, lint-free cloth.**
- ⇒ **Blow out the threaded bore with compressed air if necessary.**

- 1.4 Clean the threaded bore and contact surface on the camshaft controller ⇒ *Replacing fastening screw on cyl. 1-4-2-* using a clean, lint-free cloth. Then remove any remaining engine oil from the threaded bore using compressed air.
- 1.5 Screw in new fastening screw ⇒ *Replacing fastening screw on cyl. 1-4-1-*, Part No. 999.067.803.30, on the camshaft controller ⇒ *Replacing fastening screw on cyl. 1-4-2-* and tighten with the torque wrench **9768 - Electronic torque wrench, 2 - 100 Nm/1.5 - 74 ftlb.** using the **two-step tightening procedure**:
- Step 1: **Tightening torque 6 Nm (4.5 ftlb.) +0.5 Nm (+0.5 ftlb.)**
 - Step 2: **Torque angle 60° +5°**

**Information**

The **tightening torque for the fastening screws** for the camshaft controller achieved using the two-step tightening procedure must be **8 – 14 Nm/6 – 10.5 ftlb.**
Once the two-step tightening procedure is complete, the torque will be displayed on the electronic torque wrench display.

If this **tightening torque is not reached**, the relevant fastening screw must be **removed again**. Then clean the threaded bore again, screw in a **new fastening screw**, Part No. 999.067.803.30, and tighten using the prescribed two-step tightening procedure.

If the resultant tightening torque of **8 – 14 Nm/6 – 10.5 ftlb. is not reached several times**, the relevant **camshaft controller must be replaced**.

In this case, first replace the **fastening screws for the camshaft controller for cylinder bank 5–8** as described in Step 2 and then replace the affected camshaft controller ⇒ *Technical Information 'AH0800 Replacing camshaft controller'*.

- 1.6 After screwing in the fastening screw ⇒ *Replacing fastening screw on cyl. 1–4-1-* to the prescribed tightening torque, mark it with a water-resistant marker.
- 1.7 Remove adhesive tape or cloth from the contact area of the tool on the camshaft.
- 1.8 To replace the other fastening screws on the camshaft controller on cylinder bank 1–4, **turn the engine at the vibration balancer 180° in rolling direction** and then repeat **Steps 1.2 to 1.7** until you have replaced all fastening screws.

NOTICE

Loosening several fastening screws on the camshaft controller at the same time

- **Damage to the camshaft controller**
- **Adjustment of valve timing for camshaft drive**
- **Damage to the valve drive**

⇒ **Replace fastening screws for the camshaft controller individually, one at a time**

- 2 Replace fastening screws ⇒ *Fastening screws for camshaft controller on cyl. 5-8-1-* for the camshaft controller on cylinder bank 5-8 ⇒ *Fastening screws for camshaft controller on cyl. 5-8-2-*.

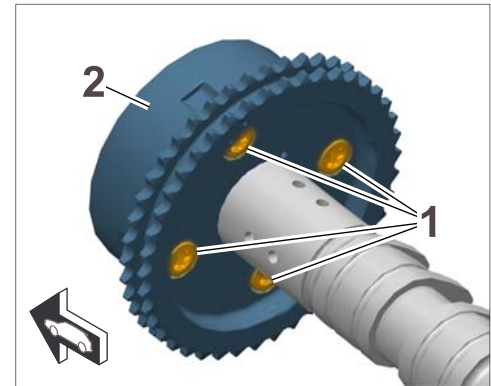

Fastening screws for camshaft controller on cyl. 5-8

- 2.1 Use the tool **9714 - socket-wrench insert** to turn the engine at the vibration balancer in rolling direction until one of the fastening screws ⇒ *Turning engine to assembly position, cyl. 5-8-1-* for the camshaft controller ⇒ *Turning engine to assembly position, cyl. 5-8-2-* on cylinder bank 5-8 is at the same height as the flattened area on the mounting saddle for the intake camshaft.

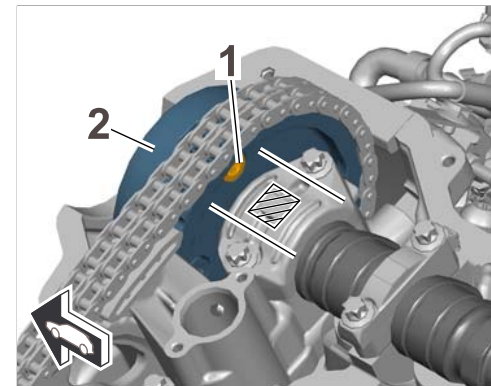

Turning engine to assembly position, cyl. 5-8



Information

For easy access and to prevent damage to the cylinder head or valve drive, the threaded joint on the camshaft controllers must be loosened and tightened using the prescribed Torx

socket-wrench insert. The use of this Torx socket-wrench insert ensures that the tool can be fitted correctly on the screw heads.

- 2.2 Cover the contact surface ⇒ *Covering contact surface -A-* on the camshaft with adhesive tape or a clean, lint-free cloth to prevent damage to the camshaft when replacing the fastening screws using the Torx socket-wrench insert ⇒ *Covering contact surface -1-*.

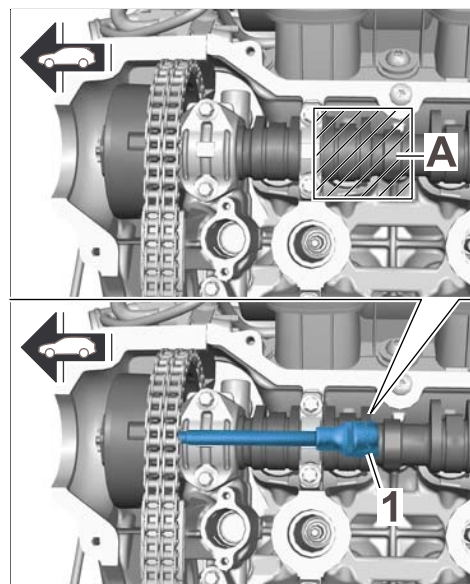

Covering contact surface

- 2.3 Unscrew and remove fastening screw ⇒ *Replacing fastening screw on cyl. 5-8-1-* for the camshaft controller ⇒ *Replacing fastening screw on cyl. 5-8-2-* using the prescribed Torx socket-wrench insert.



Information

If **one or more fastening screws** for the camshaft controller have **already become loose** and can be **unscrewed and removed by hand**, the **camshaft controller must be replaced**; ⇒ *Technical Information 'AF0200 Replacing camshaft controller'*.

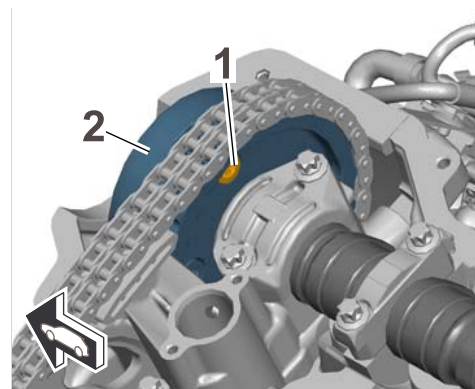

Replacing fastening screw on cyl. 5-8

NOTICE

Improper handling of the camshaft controller

- **Damage to the camshaft controller**
- ⇒ **Do not use any degreasing liquid cleaning agents.**
- ⇒ **Clean the threaded bore and contact surface of the camshaft controller only using a clean, lint-free cloth.**

⇒ **Blow out the threaded bore with compressed air if necessary.**

- 2.4 Clean the threaded bore and contact surface on the camshaft controller ⇒ *Replacing fastening screw on cyl. 5-8-2-* using a clean, lint-free cloth. Then remove any remaining engine oil from the threaded bore using compressed air.
- 2.5 Screw in new fastening screw ⇒ *Replacing fastening screw on cyl. 5-8-1-*, Part No. 999.067.803.30, on the camshaft controller ⇒ *Replacing fastening screw on cyl. 5-8-2-* and tighten with the torque wrench **9768 - Electronic torque wrench, 2 - 100 Nm/1.5 - 74 ftlb.** using the **two-step tightening procedure**:
- Step 1: **Tightening torque 6 Nm (4.5 ftlb.) +0.5 Nm (+0.5 ftlb.)**
 - Step 2: **Torque angle 60° +5°**



Information

The **tightening torque for the fastening screws** for the camshaft controller achieved using the two-step tightening procedure must be **8 – 14 Nm/6 – 10.5 ftlb.**. Once the two-step tightening procedure is complete, the torque will be displayed on the electronic torque wrench display.

If this **tightening torque is not reached**, the relevant fastening screw must be **removed again**. Then clean the threaded bore again, screw in a **new fastening screw**, Part No. 999.067.803.30, and tighten using the prescribed two-step tightening procedure.

If the resultant tightening torque of **8 – 14 Nm/6 – 10.5 ftlb. is not reached several times**, the relevant **camshaft controller must be replaced**; ⇒ *Technical Information 'AF0200 Replacing camshaft controller'*.

- 2.6 After screwing in the fastening screw ⇒ *Replacing fastening screw on cyl. 5-8-1-* to the prescribed tightening torque, mark it with a water-resistant marker.
- 2.7 Remove adhesive tape or cloth from the contact area of the tool on the camshaft.
- 2.8 To replace the other fastening screws on the camshaft controller on cylinder bank 5-8, **turn the engine at the vibration balancer 180° in rolling direction** and then repeat **Steps 2.2 to 2.7** until you have replaced all fastening screws.

3 Complete the engine ⇒ *Technical Information 'AH0800 Concluding work'*.

Replacing camshaft controller

Parts Info: **Additional parts required for replacing the camshaft controllers:**

Part No.	Designation – Use	Qty.
94810505123	Camshaft controller – Intake camshaft	1 or 2 ea. (as required)
94810525400	Hexagon round-head bolt, M12 x 1.5 x 110 – Intake camshaft controller – Sprocket for outlet camshaft	4 ea.
90012311830	Sealing ring, A 22 x 27 – Chain tensioner	1 ea.

Tools: **Additional tools required for replacing the camshaft controllers:**



Information

Due to the **limited amount of space** between the radiator frame and vibration balancer at the crankshaft, the **locking pin 9595/1 cannot be used** in some cases for securing the crankshaft in TDC position of cylinder 1.

In this case, an **M8 screw with a length of 50 to 60 mm**, e.g. Part No. 900.385.071.01 or 999.073.411.01, must be used instead of the locking pin.

- **9595/1 - Locating pins**
- **9678/1 - Staking tool**
- **9683/1 - Auxiliary chain tensioner**
- Torque wrench, 20 – 100 Nm (15 – 74 ftlb.), e.g. **VAS 5820 - Torque wrench, 20-100 Nm (15-74 ftlb.)**

Work

Procedure:

NOTICE

Improper handling of crankshafts

- **Risk of damage to the timing system**
- ⇒ **Never turn the crankshaft against the rolling direction or when the chain tensioner is removed.**
- ⇒ **Only turn the engine at the crankshaft.**
- ⇒ **After working on the camshaft, reset valve timing.**
- ⇒ **Observe general warning notes and working regulations.**

- 1 Turn the crankshaft at the vibration balancer using the tool **9714 - socket-wrench insert** so that the staking bore \Rightarrow *Staking bore 45° before TDC -2-* of the vibration balancer is approx. 45° \Rightarrow *Staking bore 45° before TDC -3-* in front of the lower staking point \Rightarrow *Staking bore 45° before TDC -1-* on the timing-case cover.
- 2 Remove chain tensioner for the timing chain \Rightarrow *Workshop Manual '153619 Removing and installing chain tensioner'*.
- 3 Remove the affected camshaft controller and install new camshaft controller \Rightarrow *Workshop Manual '158419 Removing and installing actuator for camshaft (camshaft controller)'*.
- 4 **9683/1 - Auxiliary chain tensioner** must then be installed on the engine.
- 5 Set timing of the valve drive \Rightarrow *Workshop Manual '150516 Setting valve timing'*.
Tighten the central screws for the camshaft controllers and the fastening screws for the sprockets for the outlet camshaft using the prescribed tightening procedure.

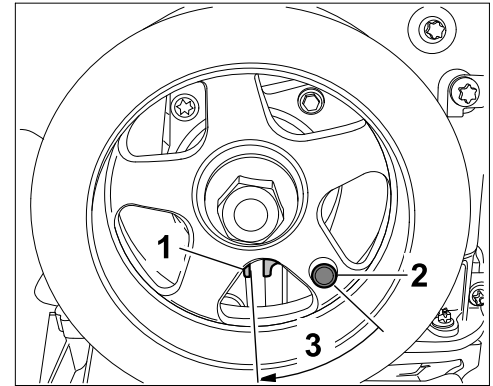

Staking bore 45° before TDC

Central screw for camshaft controller:

- Initial tightening, Step 1: **Tightening torque 10 Nm (7.5 ftlb.)**
- Initial tightening, Step 2: **Tightening torque 30 Nm (22 ftlb.)**
- Initial tightening, Step 3: **Torque angle 100°**
- Loosening process, Step 1: **Torque angle 90°**
- Loosening process, Step 2: **Torque angle 360°**
- Final tightening, Step 1: **Tightening torque 30 Nm (22 ftlb.)**
- Final tightening, Step 2: **Torque angle 135°**

Fastening screw for sprockets for outlet camshaft:

- Step 1: **Tightening torque 10 Nm (7.5 ftlb.)**
- Step 2: **Tightening torque 50 Nm (37 ftlb.)**
- Step 3: **Torque angle 90°**

- 6 Remove auxiliary chain tensioner and install chain tensioner with a new sealing ring \Rightarrow *Workshop Manual '153619 Removing and installing chain tensioner'*.

Concluding work

- Work Procedure: 1 Install spark plugs on both cylinder banks \Rightarrow *Workshop Manual '287055 Removing and installing spark plugs'*.

Information

The **space available** for loosening and tightening the **fastening screws for the cylinder head cover** may be **restricted depending on vehicle equipment**.

Always **use the tools recommended** in the Workshop Manual for carrying out repairs.

- 2 Install cylinder head covers on both cylinder banks ⇒ *Workshop Manual '158219 Removing and installing cylinder head cover'*.
- 3 Install oil mist separator on cylinder bank 5-8 ⇒ *Workshop Manual '105519 Removing and installing oil separator'*.
- 4 Install bar ignition modules on both cylinder banks ⇒ *Workshop Manual '282020 Removing and installing bar ignition modules'*.
- 5 Install engine cover on both cylinder banks ⇒ *Workshop Manual '108319 Removing and installing engine cover (design cover)'*.
- 6 Install secondary-air pump ⇒ *Workshop Manual '266519 Removing and installing secondary-air pump'*.
- 7 Install torque support ⇒ *Workshop Manual '103719 Removing and installing torque support'*.
- 8 Install cross panel for engine compartment ⇒ *Workshop Manual '508119 Removing and installing cross panel (disassembling plenum panel)'*.
- 9 Install wiper linkage ⇒ *Workshop Manual '921919 Removing and installing wiper linkage'*.
- 10 Install cowl panel cover ⇒ *Workshop Manual '508719 Removing and installing cowl panel cover'*.
- 11 Install rear profile seal for front hood ⇒ *Workshop Manual '553319 Removing and installing front lid seal'*.
- 12 Install plenum panel cover at the left and right ⇒ *Workshop Manual '852219 Removing and installing plenum panel cover'*.
- 13 Install wiper arms ⇒ *Workshop Manual '922519 Removing and installing wiper arm'*.
- 14 Close the front hood by moving it out of service position ⇒ *Workshop Manual '552213 Securing lid (service position)'*.
- 15 Enter the campaign in the Warranty and Maintenance booklet.

References: ⇒ *Workshop Manual '1001IN Tightening torques, tightening sequences, assembly overviews'*
 ⇒ *Workshop Manual '103719 Removing and installing torque support'*
 ⇒ *Workshop Manual '105519 Removing and installing oil mist separator'*

- ⇒ Workshop Manual '108319 Removing and installing engine cover (design cover)'
- ⇒ Workshop Manual '150516 Setting timing for camshafts'
- ⇒ Workshop Manual '153619 Removing and installing chain tensioner'
- ⇒ Workshop Manual '158055 Replacing cylinder-head gasket'
- ⇒ Workshop Manual '158219 Removing and installing cylinder head cover'
- ⇒ Workshop Manual '158419 Removing and installing actuator for camshaft (camshaft controller)'
- ⇒ Workshop Manual '266519 Removing and installing secondary-air pump with bracket'
- ⇒ Workshop Manual '282020 Removing and installing bar ignition modules'
- ⇒ Workshop Manual '287020 Removing and installing spark plugs'
- ⇒ Workshop Manual '2X00IN Work instructions after disconnecting the battery'
- ⇒ Workshop Manual '508119 Removing and installing cross panel (disassembling plenum panel)'
- ⇒ Workshop Manual '508719 Removing and installing cowl panel cover'
- ⇒ Workshop Manual '552213 Securing lid (service position)'
- ⇒ Workshop Manual '553319 Removing and installing front lid seal'
- ⇒ Workshop Manual '852219 Removing and installing plenum panel cover'
- ⇒ Workshop Manual '921919 Removing and installing wiper linkage'
- ⇒ Workshop Manual '922519 Removing and installing wiper arm'

Warranty processing

Information: **Scope 1 – Scope 6: Not relevant** for these **vehicle types**.



Information

The working times specified were determined especially for the performance of this campaign and may deviate from the working times published in the catalog of operations contained in PIWIS.

Scope 7: **Replacing fastening screws for both camshaft controllers**

– **No** camshaft controllers must be replaced

Working time:

Replacing fastening screws for camshaft controllers

Labor time: **569 TU**

Includes:

- Disconnecting and connecting battery
- Removing and installing wiper arms
- Removing and installing plenum panel cover at the left and right
- Removing and installing profile seal for front hood
- Removing and installing cowl panel cover
- Removing and installing wiper linkage
- Removing and installing cross panel for engine compartment
- Removing and installing torque support
- Removing and installing secondary-air pump
- Removing and installing engine cover at the left and right
- Removing and installing bar ignition modules

Without: Removing and installing oil mist separator
 Removing and installing cylinder head cover at the left and right
 Removing and installing spark plugs
 Replacing camshaft controllers
 Setting timing for valve drive

Parts required:

99906780330	Cheese head bolt, M7 x 21	8 ea.
94810514600	Hexagon round-head bolt	8 ea.
94810743720	Seal for oil mist separator	1 ea.
94810743820	Seal for oil mist separator	1 ea.
94810593501	Seal for cylinder head cover, cyl. 1–4	1 ea.
94810593601	Seal for cylinder head cover, cyl. 5–8	1 ea.
94810593702	Cylinder head cover seal, inner	8 ea.
94810593800	Actuator seal	2 ea.
99907390531	Oval-head screw, M6 x 30	23 ea.
99907390831	Oval-head screw, M8 x 35	3 ea.
WHT005204	Cheese head bolt, M10 x 80	1 ea.
WHT004595	Cheese head bolt, M10 x 90	1 ea.
WHT004635	Hexagon nut, M10	2 ea.
99907391431	Oval-head screw, M6 x 55	2 ea.
99907390231	Oval-head screw, M6 x 16	2 ea.

Required materials (usually already available in the Porsche dealership):

00004330547	Drei Bond sealing compound Silikon 2210, 30g tube	0.3
00004330515	Antifreeze, 1-liter container	0.5 liters

⇒ **Damage Code AH08 099 000 2**

Scope 8: **Replacing fastening screws for both camshaft controllers**
 – Also replacing **one camshaft controller**

Working time:

Replacing fastening screws for camshaft controllers

Labor time: **641 TU**

Includes:

- Replacing one camshaft controller
- Setting timing for valve drive
- Disconnecting and connecting battery
- Removing and installing wiper arms
- Removing and installing plenum panel cover at the left and right
- Removing and installing profile seal for front hood
- Removing and installing cowl panel cover
- Removing and installing wiper linkage
- Removing and installing cross panel for engine compartment
- Removing and installing torque support
- Removing and installing secondary-air pump
- Removing and installing engine cover at the left and right
- Removing and installing bar ignition modules
- Removing and installing oil mist separator
- Removing and installing cylinder head cover at the left and right
- Removing and installing spark plugs

Parts required:

99906780330	Cheese head bolt, M7 x 21	8 ea.
94810505123	Camshaft controller, intake	1 ea.
94810525400	Hexagon round-head bolt, M12 x 1.5 x 110	4 ea.
90012311830	Seal, A22 x 27	1 ea.
94810514600	Hexagon round-head bolt	8 ea.
94810743720	Seal for oil mist separator	1 ea.
94810743820	Seal for oil mist separator	1 ea.
94810593501	Seal for cylinder head cover, cyl. 1–4	1 ea.
94810593601	Seal for cylinder head cover, cyl. 5–8	1 ea.
94810593702	Cylinder head cover seal, inner	8 ea.
94810593800	Actuator seal	2 ea.
99907390531	Oval-head screw, M6 x 30	23 ea.
99907390831	Oval-head screw, M8 x 35	3 ea.
WHT005204	Cheese head bolt, M10 x 80	1 ea.
WHT004595	Cheese head bolt, M10 x 90	1 ea.

WHT004635	Hexagon nut, M10	2 ea.
99907391431	Oval-head screw, M6 x 55	2 ea.
99907390231	Oval-head screw, M6 x 16	2 ea.
Required materials (usually already available in the Porsche dealership):		
00004330547	Drei Bond sealing compound Silikon 2210, 30g tube	0.3
00004330515	Antifreeze, 1-liter container	0.5 liters
⇒ Damage Code AH08 099 000 2		

Scope 9:

Replacing fastening screws for both camshaft controllers

– Also replacing **both camshaft controllers**

Working time:		
Replacing fastening screws for camshaft controllers		Labor time: 643 TU
Includes:	<ul style="list-style-type: none"> Replacing both camshaft controllers Setting timing for valve drive Disconnecting and connecting battery Removing and installing wiper arms Removing and installing plenum panel cover at the left and right Removing and installing profile seal for front hood Removing and installing cowl panel cover Removing and installing wiper linkage Removing and installing cross panel for engine compartment Removing and installing torque support Removing and installing secondary-air pump Removing and installing engine cover at the left and right Removing and installing bar ignition modules Removing and installing oil mist separator Removing and installing cylinder head cover at the left and right Removing and installing spark plugs 	
Parts required:		
99906780330	Cheese head bolt, M7 x 21	8 ea.
94810505123	Camshaft controller, intake	2 ea.

94810525400	Hexagon round-head bolt, M12 x 1.5 x 110	4 ea.
90012311830	Seal, A22 x 27	1 ea.
94810514600	Hexagon round-head bolt	8 ea.
94810743720	Seal for oil mist separator	1 ea.
94810743820	Seal for oil mist separator	1 ea.
94810593501	Seal for cylinder head cover, cyl. 1–4	1 ea.
94810593601	Seal for cylinder head cover, cyl. 5–8	1 ea.
94810593702	Cylinder head cover seal, inner	8 ea.
94810593800	Actuator seal	2 ea.
99907390531	Oval-head screw, M6 x 30	23 ea.
99907390831	Oval-head screw, M8 x 35	3 ea.
WHT005204	Cheese head bolt, M10 x 80	1 ea.
WHT004595	Cheese head bolt, M10 x 90	1 ea.
WHT004635	Hexagon nut, M10	2 ea.
99907391431	Oval-head screw, M6 x 55	2 ea.
99907390231	Oval-head screw, M6 x 16	2 ea.

Required materials (usually already available in the Porsche dealership):

00004330547	Drei Bond sealing compound Silikon 2210, 30g tube	0.3
00004330515	Antifreeze, 1-liter container	0.5 liters

⇒ **Damage Code AH08 099 000 2**

Important Notice: Technical Bulletins issued by Porsche Cars North America, Inc. are intended only for use by professional automotive technicians who have attended Porsche service training courses. They are written to inform those technicians of conditions that may occur on some Porsche vehicles, or to provide information that could assist in the proper servicing of a vehicle. Porsche special tools may be necessary in order to perform certain operations identified in these bulletins. Use of tools and procedures other than those Porsche recommends in these bulletins may be detrimental to the safe operation of your vehicle, and may endanger the people working on it. Properly trained Porsche technicians have the equipment, tools, safety instructions, and know-how to do the job properly and safely. Part numbers listed in these bulletins are for reference only. The work procedures updated electronically in the Porsche PIWIS diagnostic and testing device take precedence and, in the event of a discrepancy, the work procedures in the PIWIS Tester are the ones that must be followed.

© 2018 Porsche Cars North America, Inc.