



Reliability Driven®

Service Bulletin No. 397B

<i>MODEL</i> D Series	<i>TYPE</i> Field Change Program	<i>SECTION/GROUP</i> 8-Engine	<i>DATE</i> June 13, 2017
<i>SUBJECT</i> EXHAUST SYSTEM BELLOWS PIPE			
<i>CONDITIONS</i>			

SERVICE BULLETIN 397 WAS REVISED TO REFLECT ADDITIONAL D SERIES COACHES AFFECTED BY THIS REWORK

Ref. NHTSA Recall No.:17V-337 (REISSUANCE OF 13V-142)

Ref. Transport Canada Recall No.:2017-280 (FOR PRIOR RECALL 2013-121)

Customer Complaint:

Motor Coach Industries, Inc. ("MCI") has become aware of a potential incorrect installation of the bellows pipe, which is one of the components of the exhaust system, in certain 2011-2012 D series coaches equipped with a 2010 EPA Cummins ISX engine. The bellows pipe in the affected coaches may have been installed incorrectly, which may result in the pipe becoming deformed. In this situation, the deformed pipe may prematurely fail as a result of metal fatigue.

If the deformed pipe fails and a regeneration event occurs, the combustion may not be completely contained within the exhaust system and hot combustion gases could cause a fire, potentially resulting in injury to persons and/or damage to property

Cause:

The cause is due to an incorrect assembly process related to the installation of the bellows pipe.

Corrective Action:

MCI strongly encourages owners of the D model coaches listed in the table below to perform the procedures in this bulletin as soon as possible.

12604 to 12682	12684 to 12689	59742	59764 to 59786	59788 to 59789
59829 to 59845	59861 to 59894	59896 to 59906	59923	59989 to 59992



Parts

Qty.	New P/N	Description
1	08-20-2350	Bracket, Exhaust pipe, ISX 12 L
a/r	08-20-1786	Exhaust pipe, ISX 12 L (as required upon inspection)
a/r	08-20-1905	Blanket, Exhaust pipe, ISX 12 L (as required upon inspection
a/r	19-01-1543	Capscrew, 3/8-16 x 3/4
a/r	19-03-0535	Locknut

Service Procedure:



***Read this entire procedure before beginning work.
Use Safe Shop Practices At All Times.***



To avoid personal injury, never enter or perform work in the engine compartment prior to positioning the ENGINE RUN and ENGINE START switches on the engine compartment remote control box to the OFF position. Allow enough time for components to cool down prior to working in the engine compartment.

The exhaust system bellows pipe may be hot, so allow enough time for the bellows pipe to cool down to ambient temperature.

1. Turn the main battery disconnect to the OFF position.
2. Chock both sides of the tires.
3. Open the engine compartment doors and locate the exhaust system bellows pipe (refer to Figure 1).

4. Remove and retain the blanket on the turbo side of the installation, and place the blanket on a workbench.
5. Locate and remove the existing two (2) capscrews and locknuts from the pipe assembly bracket where it attaches to the coach frame (refer to Figure 1). Remove and retain the mounting hardware to be re-installed at a later step in this procedure. Discard the existing pipe assembly bracket.

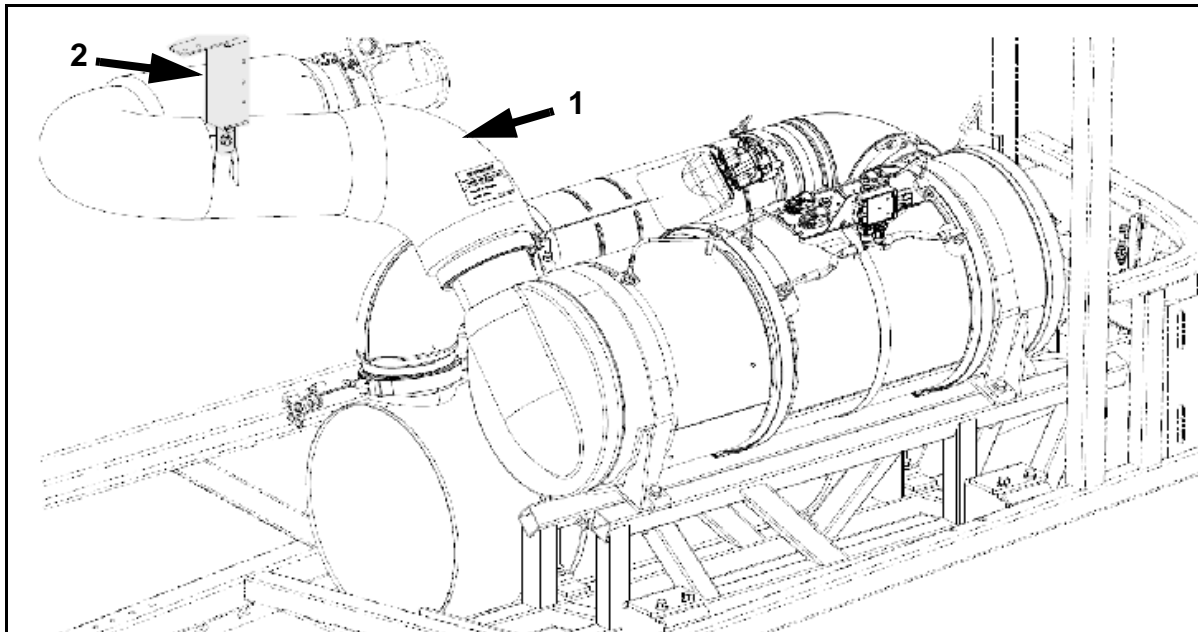

Figure 1. Exhaust system bellows pipe.

Item	Figure 1 Description
1	Blanket, exhaust system bellows pipe
2	Pipe assembly bracket existing capscrews and locknuts

6. On the turbo and exhaust side of the installation, untighten the clamps from the exhaust pipe.
7. Remove the bellows pipe and place on a workbench.

NOTICE

Replacement of the existing bellows pipe is required if any one (1) of the following three (3) failures is exhibited upon visual inspection: (a photo of the failure is required for claim submittal):

- 1. the interior jacket of the blanket has evidence of smoke leaks and soot (refer to Figure 2); or**



Figure 2.

- 2. the bellows pipe has a crack or evidence of breakage (refer to Figure 3); or**



Figure 3.

3. the bellows pipe has a gap of more than 0.250 inch between a straight edge and the bellows due to permanent deformation, when a straight edge is positioned over the bellows at multiple positions around the circumference (refer to Figure 4).

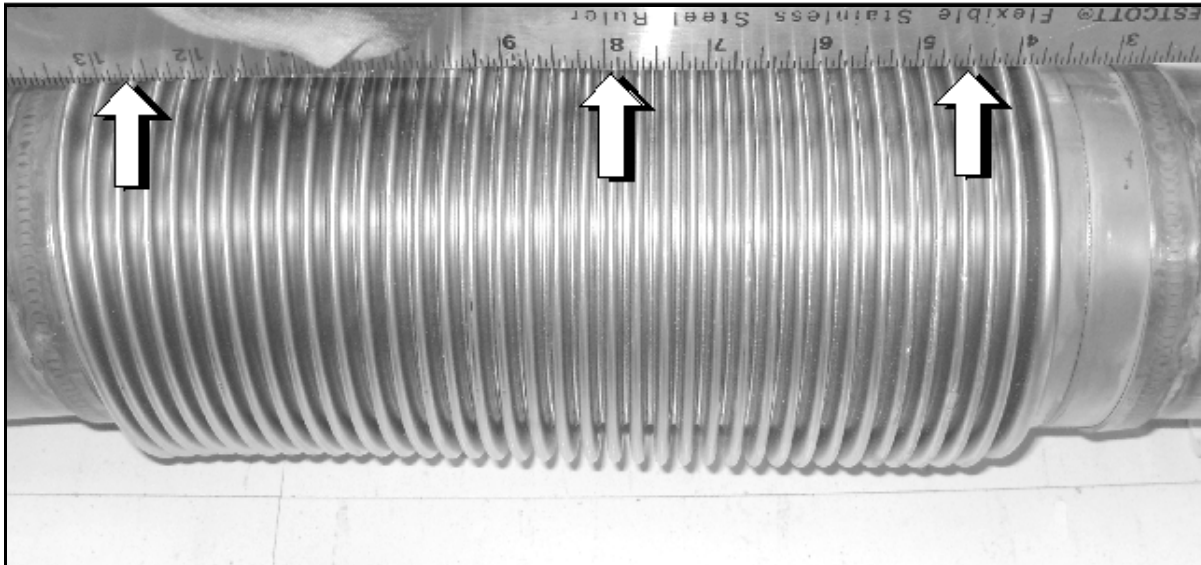

Figure 4.

NOTICE

If any one (1) of the above three (3) conditions exists, a new bellows pipe, p/n 08-20-1786, is required to be installed in Step 8. of this procedure.

If none of the above three (3) conditions exists, proceed to Step 8. of this procedure to re-install the existing bellows pipe.

8. Orient and position the bellows pipe in the coach. Rotate the "swivel" pipe end until it aligns with the mating surface (refer to Figure 5).



Figure 5.

9. Position a straight edge over the bellows at multiple positions around the circumference to ensure there is no deformation or gaps (refer to Figure 6) prior to tightening the clamps. Orient as required to achieve no deformation or gaps.

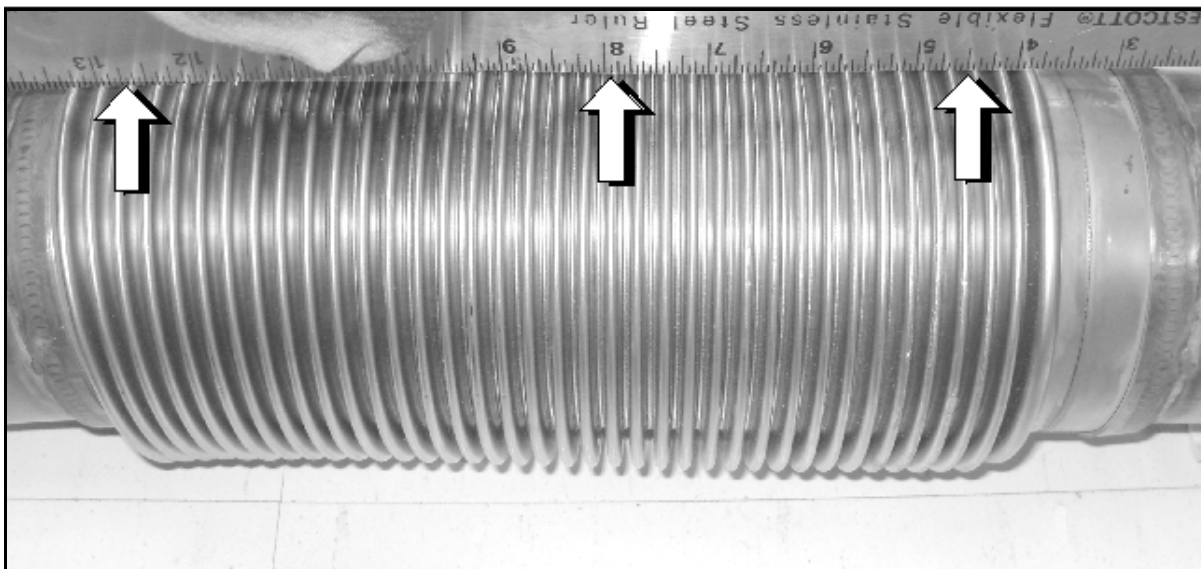

Figure 6.

10. Orient the exhaust pipe seat, and tighten the clamps to the exhaust pipe per the following steps:
 - a. Torque the clamp, Item 1 in Figure 8, to 86-95 in-lbs. Torque the clamp, Item 2 in Figure 8, to 100-110 in-lbs.
 - b. Tap around the clamps in three (3) places with a rubber mallet,
 - c. Re-torque the clamps,
 - d. Tap around the clamps in three (3) places with a rubber mallet,
 - e. Re-torque the clamps.

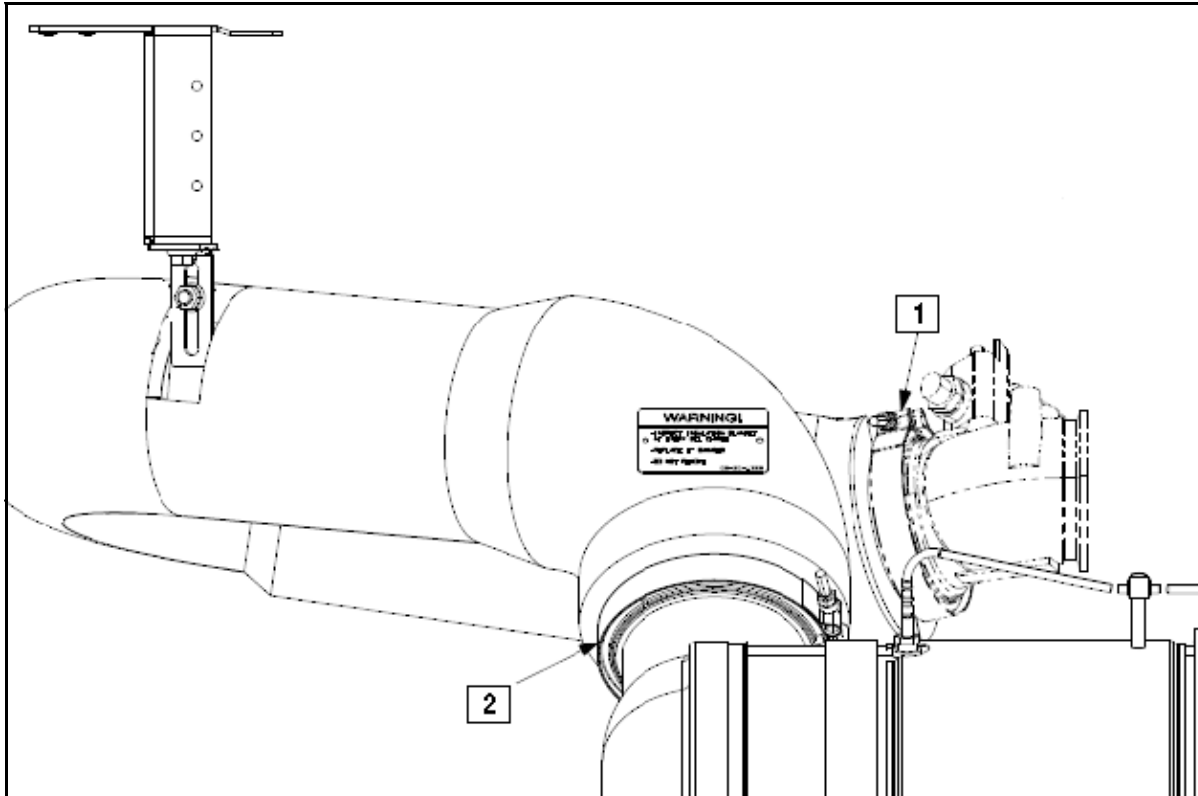

Figure 7.

Item	Description
1	Torque to 86-95 in-lbs
2	Torque to 100-110 in-lbs

11. Locate the pipe assembly bracket where it attaches to the coach frame (refer to Figure 8).
12. Using the mounting hardware removed in Step 5. and new bracket, p/n 08-20-2350, secure the bracket to the coach frame. Torque to 33-37 ft-lbs.



Figure 8.

Item	Figure 8 Description
1	Bracket, p/n 08-20-2350

NOTICE

Replacement of the existing exhaust pipe blanket is required if evidence of melting and charring is exhibited upon visual inspection (a photo of the melting and charring on the interior jacket of the blanket is required for claim submittal).



13. Inspect the interior jacket of the blanket for evidence of melting and/or charring. If melting and/or charring is present upon visual inspection, take a digital photo and submit to MCI.

NOTICE

If the interior jacket of the blanket exhibits the evidence of melting and/or charring, a new blanket, p/n 08-20-1905, is required to be installed in Step 14. of this procedure.

If the interior jacket of the blanket doesn't exhibit the evidence of melting and/or charring, proceed to Step 14. of this procedure to re-install the existing blanket.

14. Orient and re-install the blanket over the exhaust pipe.

15. Close the engine compartment doors.

Procedure Complete.

Mail or fax the completed limited warranty claim form and verification form to MCI's warranty department, or photocopy and mail to:

MCI Fleet Support
Attn: Warranty Department
7001 Universal Coach Drive
Louisville, KY 40258
Fax Number 1-800-360-8886

to receive credit for the hours used to complete this task. Contact the MCI Fleet Support Technical Center at 1-800-241-2947 for any further information.

Field Change Program Conditions:

The parts required for this change will be supplied without charge.

A labor allowance of 1.0 hour will be granted for the procedure of inspecting and, if necessary, installing the specified part(s) in this bulletin on affected D series coaches.

This labor allowance will be credited to your MCI Fleet Support Parts Account on receipt of the attached "MCI Field Change Program Verification Form" and a "Warranty Claim Form" as detailed in your Owner Warranty manual to MCI's Warranty department. A "MCI Field Change Program Verification Form" needs to be submitted for each VIN affected. Photocopy the attached "MCI Field Change Program Verification Form" as required for the number of affected coaches in your fleet.

Motor Coach apologizes for any inconvenience resulting from this campaign, but urges you to implement this change as soon as possible.

Sincerely,

Motor Coach Industries



Reliability Driven™

MCI FIELD CHANGE PROGRAM (FCP) VERIFICATION

CONTACT INFORMATION	
CUSTOMER NAME: _____	
<small>(PLEASE PRINT)</small>	
FCP INFORMATION – ONE FORM PER UNIT	
FCP#: _____	Coach Model _____ Model Year _____
COACH SERIAL #: <small>(At least the last 5 digits)</small>	DATE COMPLETED __ / __ / __
MILEAGE:	
<u>IMPORTANT:</u> TO RECEIVE CREDIT FOR ANY ALLOWABLE LABOR CHARGES, THIS VERIFICATION FORM MUST BE RETURNED TO MCI UPON COMPLETION OF THE FCP.	
SUBMITTED BY: (Please Print) _____	
	DATE __ / __ / __
TITLE: (Please Print) _____	
SIGNATURE: _____	
COMMENTS: 	

FAX TO: 800-360-8886

MAILING ADDRESS:

**MOTOR COACH INDUSTRIES
ATTN: WARRANTY DEPT.
7001 UNIVERSAL COACH DRIVE
LOUISVILLE, KY 40258**