



**SAFETY
RECALL**

SR17-09

DATE :	May 2017	SECTION :	23 ACCESSORIES
SUBJECT:	LOWER WINDSHIELD WIPER ARMS INSPECTION		

APPLICATION

NOTICE TO SERVICE CENTERS	
<i>Verify vehicle eligibility by checking warranty bulletin status with SAP or via ONLINE WARRANTY SYSTEM available on Service / Warranty tab of PrevoSt website.</i>	
Model	VIN 
H3-41, H3-45 coaches Model Year : 2016 - 2017	From 2PCH33496GC71 <u>3394</u> up to 2PCH33491HC71 <u>3689</u> incl.
H3-45 VIP motorhomes Model Year : 2016 - 2017	From 2PCVS3497GC71 <u>3393</u> up to 2PCVS3492HC71 <u>3657</u> incl.
<p>This Safety Recall does not necessarily apply to all the above-mentioned vehicles, some vehicles may have been modified before delivery. The owners of the vehicles affected by this recall will be advised by a letter indicating the Vehicle Identification Number (VIN) of each vehicle concerned.</p>	

DESCRIPTION

On the vehicles affected by this bulletin, it is necessary to inspect the two lower windshield wiper arms. A design defect present on a particular design of wiper arm may cause premature failure of the wiper arm, making them unusable. The inspection will identify the type of wiper arms that are currently installed on the vehicle and thereby determine if the wiper arms need to be replaced.

MATERIAL

If **PART 1** has demonstrated that at least, one wiper arm must be replaced, order kit "**WB17-09**" which contains the following parts:

Part No.	Description	Qty
800002	ARM, WIPER LOWER	2
800003	NUT, WIPER ARM 3/8-24 UNF	2

NOTE
<i>Material can be obtained through regular channels.</i>

PROCEDURE



DANGER

Park vehicle safely, apply parking brake, stop engine. Prior to working on the vehicle, set the ignition switch to the OFF position and trip the main circuit breakers equipped with a trip button.

PART 1 – INSPECTION

WIPER ARMS INSPECTION

1. Using a mirror, identify the type of wiper arm head casting design (FIGURE 1).



FIGURE 1

2. If both wiper arms are of the « **improved design** » (FIGURE 2), no replacement is needed. No other verification is required.
3. If at least, one wiper arm is of the « **original design** », then replace both wiper arms using kit **WB17-09** as per the instructions of PART 2.



FIGURE 2

PART 2 – REPLACEMENT

REMOVAL OF DEFECTIVE WIPER ARMS

1. Disconnect the windshield washer liquid hoses (FIGURE 3).

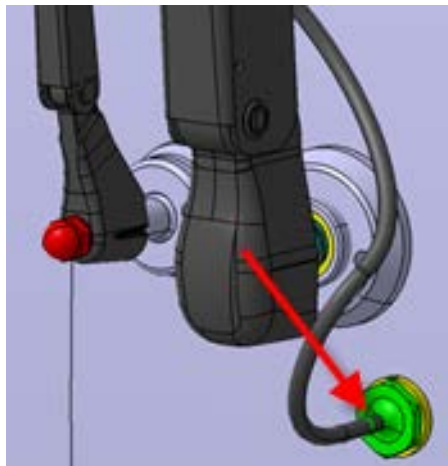

FIGURE 3

2. Remove the R.H. & L.H. side wiper lower wiper arms.
3. To ease removal, pull the arm away from the windshield (1) and then insert a small nail through the hole shown (2) to lock the wiper arm in that position (FIGURE 4).

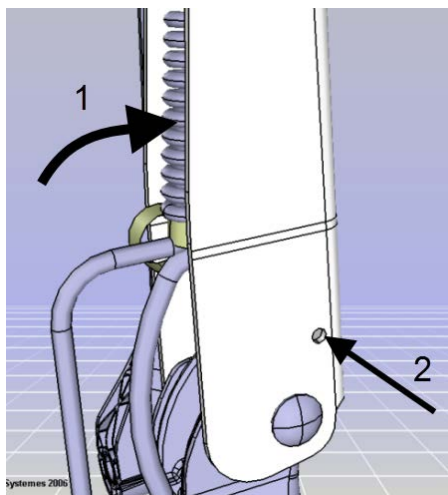

FIGURE 4

4. Loosen nut C and then remove nut A & B (FIGURE 5).
5. Remove the wiper arms.

Note:

Save the wiper arms. Components on the wiper arms must be reinstalled on the new wiper arms.

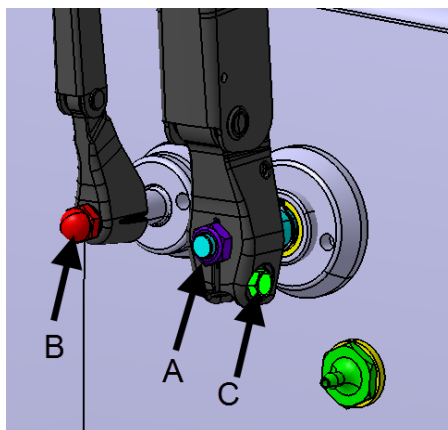

FIGURE 5

6. Remove and save the rubber tube from each wiper arm (FIGURE 6). The rubber tubes must be reinstalled on the new wiper arms.

Note:

If necessary, spray soapy water on the tubes to facilitate their removal.

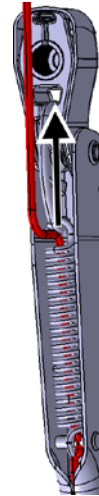

FIGURE 6

NEW WIPER ARM PREPARATION (perform on each arm)

7. Remove and discard the rubber tubes from the new wiper arms.

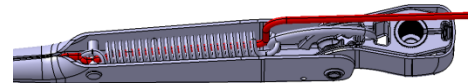

FIGURE 7

8. Insert the hose recovered on the former arms and insert into the new arms through the hole indicated on FIGURE 8.

Note:

If necessary, spray soapy water on the tubes to facilitate insertion.

9. Leave the following length of hose outside the hole:

- L.H. arm: **205mm** long
- R.H. arm: **180mm** long

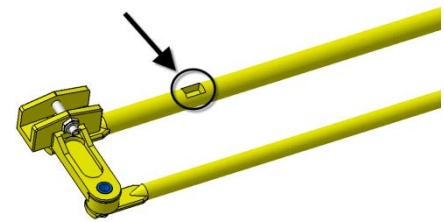

FIGURE 8

10. Route the rubber tube through the wiper arm spring (FIGURE 9PART 2).

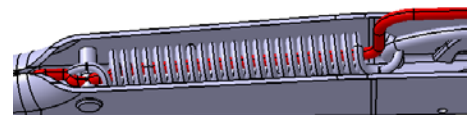

FIGURE 9

PREPARATION – LEFT SIDE WIPER ARM (driver side)

11. Save the windshield washer nozzle bracket and reinstall on the new L.H. side (driver side) wiper arm (FIGURE 10).
12. Route the tube through the rubber grommet and then connect to the washer nozzle. User soapy water on the fitting to ease connection of the hose.

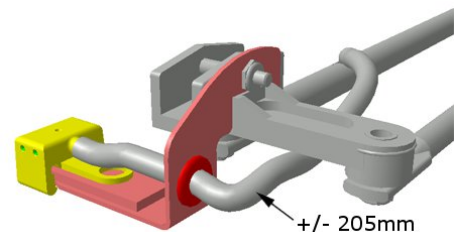

FIGURE 10: L.H. SIDE WIPER ARM

PREPARATION – RIGHT SIDE WIPER ARM

13. Save the windshield washer nozzle and reinstall on the new R.H. side (curb side) wiper arm. It is secured with a metal clip (FIGURE 11).
14. Connect the rubber hose to the washer nozzle.

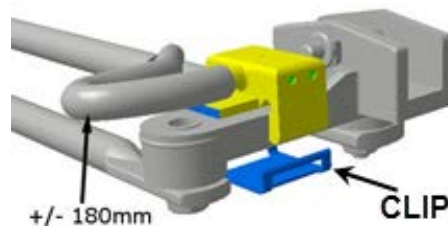

FIGURE 11: R.H. SIDE WIPER ARM

WIPER BLADE INSTALLATION

15. Install the wiper blade with the bumper opposite to the wiper arm (FIGURE 12).



FIGURE 12

PROPER POSITION OF WIPER ARMS

16. The wiper arms should be positioned in accordance with the diagram on the right (FIGURE 13).

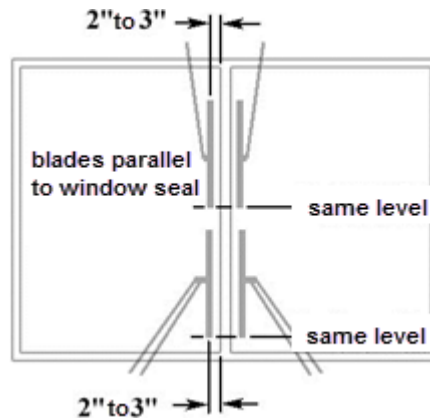

FIGURE 13

WIPER ARMS INSTALLATION

17. Install the wiper arms on the shafts.

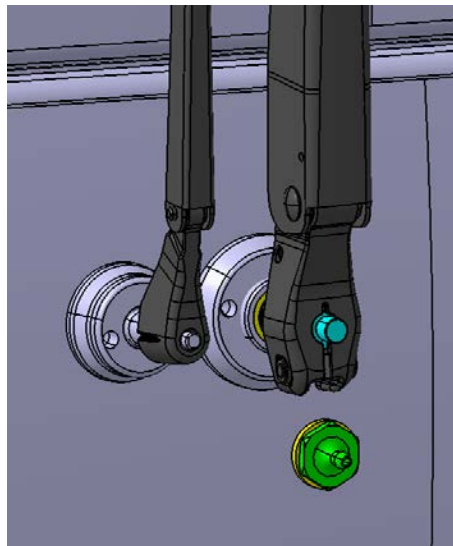

FIGURE 14 : L.H. SIDE WIPER ARM

18. Fasten the wiper arms.

Note :

Nut A is part #800003.

Nut B recovered from the old wiper arm.

Nut C is provided with the new wiper arm.

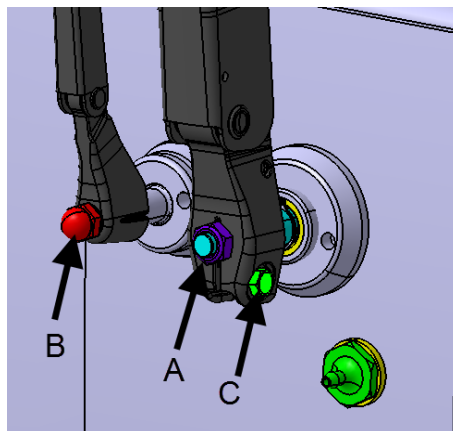

FIGURE 15 : R.H. SIDE WIPER ARM

TORQUES

Nut A : 100 lbf-ft

Nut B : 48 lbf- ft

Nut C : 160 lbf- ft

CONNECTION OF RUBBER HOSE

19. Adjust the hose exceeding the lower part of the arm. Make sure that the length of hose outside the hole is 13 in. (343 mm).

Note: The hose should not touch the wiper mechanism and must not be strained. Readjust if necessary.

20. Connect the hose to the fitting.

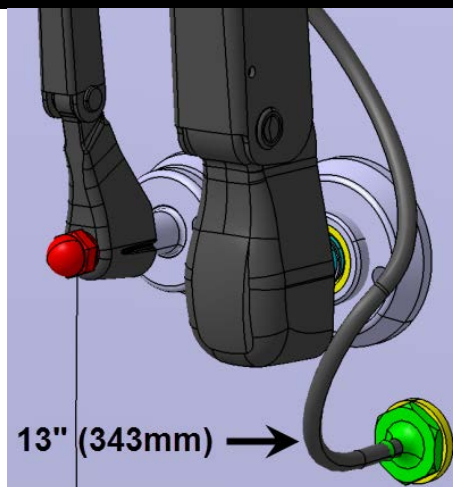

FIGURE 16

JETS ADJUSTMENT

21. Adjust the jets position such a way that the washer jets reach the windshield at the locations indicated with a « * » symbol (FIGURE 17).

22. To adjust, insert a needle into the hole and rotate the ball according to the desired position of the jets.

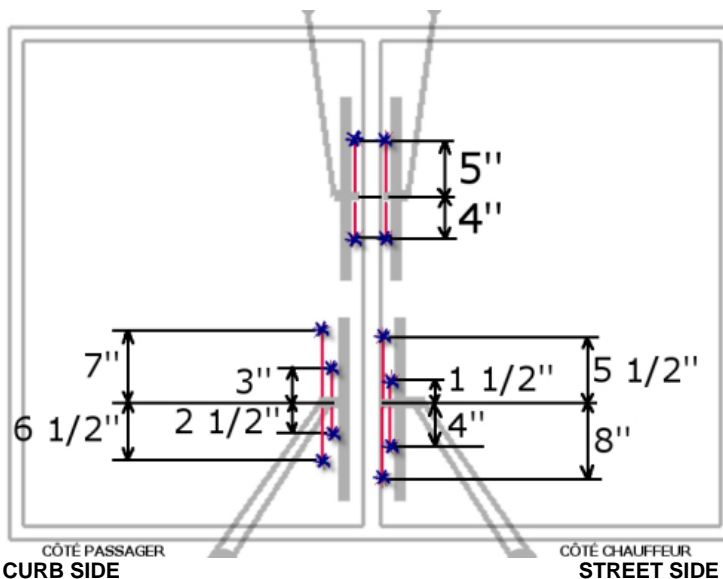

FIGURE 17



CAUTION

REPLACED WIPER ARMS MUST NOT BE STORED OR REUSED.

PARTS DISPOSITION

All replaced parts must be returned to Prevost according to the Return Shipping Instructions available on www.prevostcar.com (under service / warranty section) for full reimbursement. A copy of the warranty claim form must be enclosed with the shipment.

WARRANTY

PART 2 (replacement of wiper arms) is covered by Prevost's normal warranty. We will reimburse you the parts and one hour (1.0) of labor upon receipt of a completed A.F.A. Please submit claim via our Online Warranty System, available at www.prevostcar.com (under service \ warranty section). Use Claim Type: "Bulletin/Recall" and select "Safety Recall SR17-09".

Should you only wish to close the safety recall (without reimbursement), fill-in the "Safety Recall Certification Sheet" provided with this bulletin and return it to our warranty department by Email at prevost.onlinewarranty@volvo.com or by fax at 418-831-9301.

OTHER

VBC Bulletin	N/A
Fail Code	23.05
Defect Code	09
Syst.Cond	B
Causal Part	800002

Access all our Service Bulletins on <http://techpub.prevostcar.com/en/> or scan the QR-Code with your smart phone.
E-mail us at technicalpublications_prev@volvo.com and type "ADD" in the subject to receive our warranty bulletins by e-mail.





**Safety Recall
Certification Sheet
(Ref: SR17-09)**

VEHICLE SERIAL NUMBER:

2	P	C																	
---	---	---	--	--	--	--	--	--	--	--	--	--	--	--	--	--	--	--	--

PERFORMED BY		OWNER/OPERATOR	
We hereby certify that Safety Recall Instructions with regard to Safety Recall SR17-XX have been performed.			
Name: _____		Name: _____	
Addr: _____		Addr: _____	
Phone: _____		Phone: _____	
Fax: _____		Fax: _____	
Signature : _____	_____	Signature : _____	_____
Date: _____	_____	Date: _____	_____

If the information mentioned above is incorrect or you are not the owner of this vehicle anymore, please fill this section and return to sender.

NEW OWNER: _____

BUSINESS: _____

ADDRESS (including County): _____

TELEPHONE: _____ **FAX:** _____

Please return this completed document with your A.F.A. form