

Safety Recall

Code: 6908



Subject	Autoliv Rear Seat Safety Belt Pretensioners
Release Date	June 23, 2017
Affected Vehicles	U.S.A. & CANADA: 2017 MY Audi A5 Cabriolet/S5 Cabriolet <i>Check Campaigns/Actions screen in Elsa on the day of repair to verify that a VIN qualifies for repair under this action. Elsa is the <u>only</u> valid campaign inquiry & verification source.</i> <ul style="list-style-type: none">✓ Campaign status must show "open."✓ If Elsa shows other open action(s), inform your customer so that the work can also be completed at the same time the vehicle is in the workshop for this campaign.
Problem Description	Affected vehicles have safety belt pretensioners manufactured by Autoliv. Due to a manufacturing defect, the micro-gas generator within the pretensioner could detach during a crash with high load/safety belt pretensioner deployment. If this happens, the micro-gas generator could enter the passenger compartment, possibly striking and injuring vehicle occupants (even though the safety belts will perform as designed).
Corrective Action	Replace the affected safety belt retractors/pretensioners.
Parts Information	Due to the VIN-specific nature of the parts needed to complete this recall, parts allocation will be limited to vehicles currently in dealer inventory. Dealers scheduling customer vehicle repairs, please contact the Parts Specialists via phone (800-767-6552, option#2), email (VWoAPartsSpecialists@vw.com) or chat with the VIN to order and ensure that parts are on-hand when the vehicle arrives at the dealership for the scheduled repair appointment.
Code Visibility	<p>On or about June 23, 2017 affected vehicles will be listed on the Inventory Vehicle Open Campaign Action report under My Dealership Reports (found on www.accessaudi.com & OMD Web). A list will not be posted for dealers who do not have any affected vehicles.</p> <p>On or about June 23, 2017, this campaign code will show open on affected vehicles in Elsa.</p> <p>On or about June 23, 2017, affected vehicles will be identified with this campaign code in the VIN Lookup tool at www.audiusa.com and on the NHTSA VIN lookup tool at www.safercar.gov.</p>
Owner Notification	Owner notification will take place in June 2017. Owner letter examples are included in this bulletin for your reference.
Additional Information	<p>Please alert everyone in your dealership about this action, including Sales, Service, Parts and Accounting personnel. Contact Warranty if you have any questions.</p> <p>IMPORTANT REMINDER ON VEHICLES AFFECTED BY SAFETY & COMPLIANCE RECALLS</p> <p><u>New Vehicles in Dealer Inventory:</u> It is a violation of Federal law for a dealer to deliver a new motor vehicle or any new or used item of motor vehicle equipment (including a tire) covered by this notification under a sale or lease until the defect or noncompliance is remedied. By law, dealers must correct, prior to delivery for sale or lease, any vehicle that fails to comply with an applicable Federal Motor Vehicle Safety Standard or that contains a defect relating to motor vehicle safety.</p> <p><u>Pre-Owned Vehicles in Dealer Inventory:</u> Dealers should not deliver any pre-owned vehicles in their inventory which are involved in a safety or compliance recall until the defect has been remedied.</p> <p>Dealers must ensure that every affected inventory vehicle has this campaign completed <u>before</u> delivery to consumers.</p>

Customer Letter Example (USA)

<MONTH YEAR>

<CUSTOMER NAME>

<CUSTOMER ADDRESS>

<CUSTOMER CITY STATE ZIPCODE>

This notice applies to your vehicle: <VIN>

NHTSA: 17V150

**Subject: Safety Recall 6908 – Autoliv Rear Seat Safety Belt Pretensioners
Certain 2017 Model Year Audi A5 Cabriolet and Audi S5 Cabriolet**

Dear Audi Owner,

This notice is sent to you in accordance with the National Traffic and Motor Vehicle Safety Act. Audi has decided that a defect, which relates to motor vehicle safety, exists in certain 2017 model year Audi A5 Cabriolet and Audi S5 Cabriolet vehicles. Our records show that you are the owner of a vehicle affected by this action.

What is the issue? Affected vehicles have safety belt pretensioners manufactured by Autoliv. Due to a manufacturing defect, the micro-gas generator within the pretensioner could detach during a crash with high load/safety belt pretensioner deployment. If this happens, the micro-gas generator could enter the passenger compartment, possibly striking and injuring vehicle occupants.

What will we do? To correct this defect, your authorized Audi dealer will replace the affected safety belt retractors/pretensioners. This work will take about three hours to complete and will be performed for you free of charge.

What should you do? Please call your authorized Audi dealer without delay to schedule this recall repair. Your dealer must special order the parts needed to complete this recall repair on your vehicle. Your dealer will ensure that the correct parts are available at the dealership when you arrive for your scheduled appointment.

Lease vehicles and address changes If you are the lessor and registered owner of the vehicle identified in this action, the law requires you to forward this letter immediately via first-class mail to the lessee within ten (10) days of receipt. If you have changed your address or sold the vehicle, please fill out the enclosed prepaid Owner Reply card and mail it to us so we can update our records.

Can we assist you further? If your authorized Audi dealer fails or is unable to complete this work free of charge within a reasonable time, please contact Audi Customer Experience at 1-800-253-2834 or via our "Contact Us" page at www.audiusa.com.

Checking your vehicle for open Recalls and Service Campaigns To check your vehicle's eligibility for repair under this or any other recall/service campaign, please visit the **Recall/Service Campaign Lookup** tool at www.audiusa.com and enter your Vehicle Identification Number (VIN).

If you still cannot obtain satisfaction, you may file a complaint with: The Administrator, National Highway Traffic Safety Administration, 1200 New Jersey Avenue, SE., Washington, DC 20590; or call the toll-free Vehicle Safety Hotline at 1-888-327-4236 (TTY: 1-800-424-9153); or go to <http://www.safercar.gov>.

We apologize for any inconvenience this matter may cause; however we are taking this action to help ensure your safety and continued satisfaction with your vehicle.

Sincerely,

Audi Customer Protection

Customer Letter Example (CANADA)

<MONTH YEAR>

<CUSTOMER NAME>

<CUSTOMER ADDRESS>

<CUSTOMER CITY STATE ZIPCODE>

This notice applies to your vehicle: <VIN>

**Subject: Safety Recall 6908 – Autoliv Rear Seat Safety Belt Pretensioners
Certain 2017 Model Year Audi A5 Cabriolet and Audi S5 Cabriolet**

Dear Audi Owner,

This notice is sent to you in accordance with the requirements of the Motor Vehicle Safety Act. Audi has decided that a defect, which relates to motor vehicle safety, exists in certain 2017 model year Audi A5 Cabriolet and Audi S5 Cabriolet vehicles. Our records show that you are the owner of a vehicle affected by this action.

What is the issue? Affected vehicles have safety belt pretensioners manufactured by Autoliv. Due to a manufacturing defect, the micro-gas generator within the pretensioner could detach during a crash with high load/safety belt pretensioner deployment. If this happens, the micro-gas generator could enter the passenger compartment, possibly striking and injuring vehicle occupants (even though the safety belts will perform as designed).

What will we do? To correct this defect, your authorized Audi dealer will replace the affected safety belt retractors/pretensioners. This work will take will take about three hours to complete and will be performed for you free of charge.

What should you do? Please call your authorized Audi dealer without delay to schedule this recall repair. Your dealer must special order the parts needed to complete this recall repair on your vehicle. Your dealer will ensure that the correct parts are available at the dealership when you arrive for your scheduled appointment.

Lease vehicles and address changes If you are the lessor and registered owner of the vehicle identified in this action, the law requires you to forward this letter immediately via first-class mail to the lessee within ten (10) days of receipt. If you have changed your address or sold the vehicle, please fill out the enclosed prepaid Owner Reply card and mail it to us so we can update our records.

Can we assist you further? If your authorized Audi dealer fails or is unable to complete this work free of charge within a reasonable time, please contact Audi Customer Relations Monday through Friday from 8AM to 8PM EST at 1-800-822-2834 or via our "Contact Audi Canada" page at www.audi.ca.

We apologize for any inconvenience this matter may cause; however we are taking this action to help ensure your safety and continued satisfaction with your vehicle.

Sincerely,

Audi Customer Protection

⚠ WARNING

Risk of injury. Refer to “Warning and Safety Precautions”, found in **Appendix A** at the end of this document.

❗ NOTE

- Damages resulting from improper repair or failure to follow these work instructions are the dealer's responsibility and are not eligible for reimbursement under this action.
- This procedure must be read in its entirety prior to performing the repair.
- Due to variations in vehicle equipment and options, the steps/illustrations in this work procedure may not identically match all affected vehicles.
- Diagnosis and repair of pre-existing conditions that exist in the vehicle are not covered under this action.

Required Parts

<u>Criteria</u>	<u>Quantity</u>	<u>Part Number</u>	<u>Part Description</u>
HL,HR,06,08	1	8F0857805C IML	Seat Belt, rear left
	1	8F0857806C IML	Seat Belt, rear right
HR,01	1	8F0857806C V04	Seat Belt, rear right
HL,07	1	8F0857805C IMM	Seat Belt, rear left

Required Tools

	<p>Trim Removal Wedge -3409- (or equivalent)</p>		<p>Omega Clip Tool -T40280- (or equivalent)</p>
---	--	--	---

The repair information in this document is intended for use only by skilled technicians who have the proper tools, equipment and training to correctly and safely maintain your vehicle. These procedures are not intended to be attempted by "do-it-yourselfers," and you should not assume this document applies to your vehicle, or that your vehicle has the condition described. To determine whether this information applies, contact an authorized Audi dealer. ©2017 Audi of America, Inc. and Audi Canada. All Rights Reserved.

Repair Instruction

Section A - Check for Previous Repair

Applicable criteria ID(s)	Campaign/Action Status
01 ← 2	Open ← 1

EXAMPLE

- Enter the VIN in Elsa and proceed to the “Campaign/Action” screen.

TIP

On the date of repair, print this screen and keep a copy with the repair order.

- Confirm the Campaign/Action is open <arrow 1>. If the status is closed, no further work is required.
- Note the Applicable Criteria ID <arrow 2> for use in determining the correct work to be done and corresponding parts associated.

Criteria	Repair Description
HL,HR,06,08	Replace left and right, rear seat belt
HR,01	Replace only right rear seat belt
HL,07	Replace only left rear seat belt

Proceed to Section B

Section B – Repair Procedure

NOTE

- The procedures shown for seat belt replacement illustrate the driver side unless otherwise noted. The repair steps for the passenger side will be similar.
- If vehicle has criteria open for replacing both rear seat belts (Criteria HL,HR,06,08), perform the trim removal on both sides.

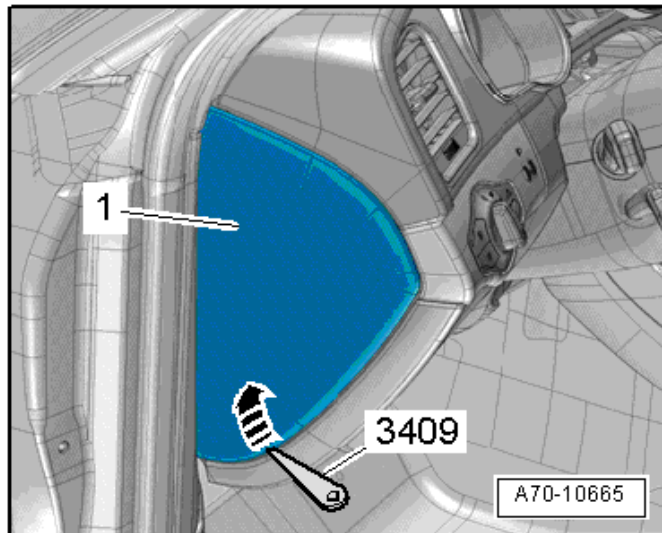

- Open the convertible top.
- Pry off the instrument panel side cover <1> using the Trim Removal Wedge -3409-.

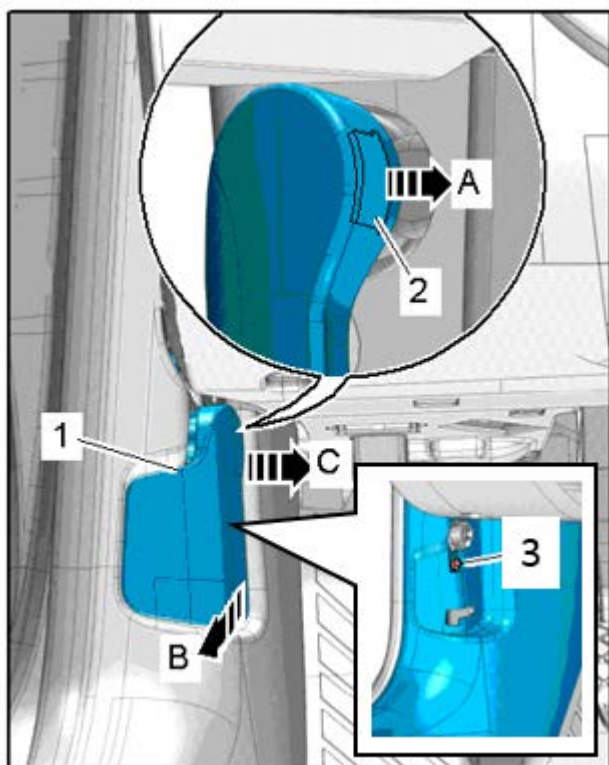

Criteria HL,HR,06,08 and HL,07 only:

- Remove the hood release lever by pulling the securing clip <2> out of the operating lever <1> slightly in direction of <arrow A> using a small screwdriver.
- Pull the operating lever back <arrow B> to release the hood and hold it in this position.
- At the same time, pull the operating lever level with the center of the vehicle and out of the mount <arrow C>.
- Remove lower A-pillar trim bolt <3>.

NOTE

Driver side is shown. For vehicles with Criteria HR,01, only the passenger side lower A-pillar trim will need to be removed and removal of the hood release lever is not necessary.

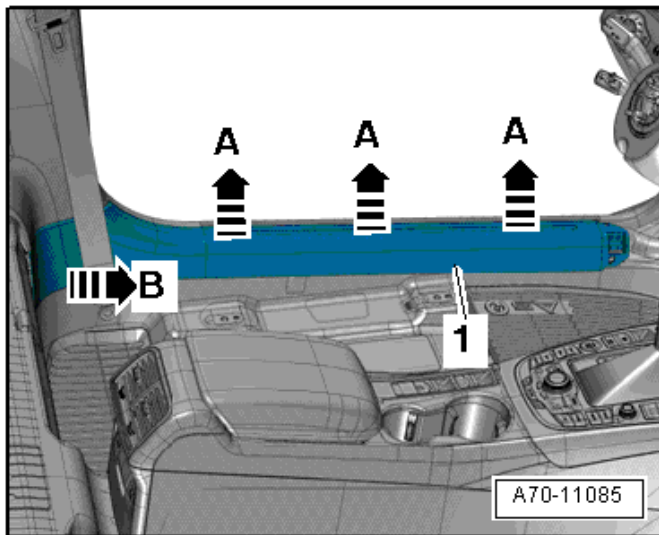

Continued for all Criteria:

- Unclip lower A-pillar trim panel from the sill <1> using the -3409-.
- Pull the lower A-pillar trim back and remove it from the upper A-pillar trim.
- Adjust the front seat and seatback all the way forward.
- Unclip sill panel strip <1> from the sill starting at the front using the -3409- <arrows A>.
- Remove the sill panel strip from the side trim by sliding in direction of <arrow B>.

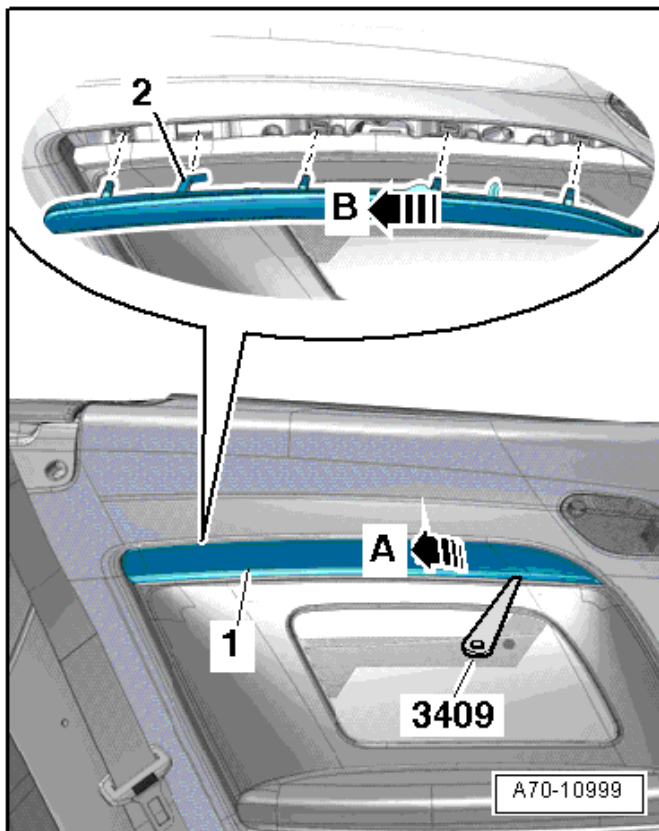

- Unclip the trim strip <1> starting at the front using a clean -3409- <arrow A> and remove toward the rear <arrow B>.

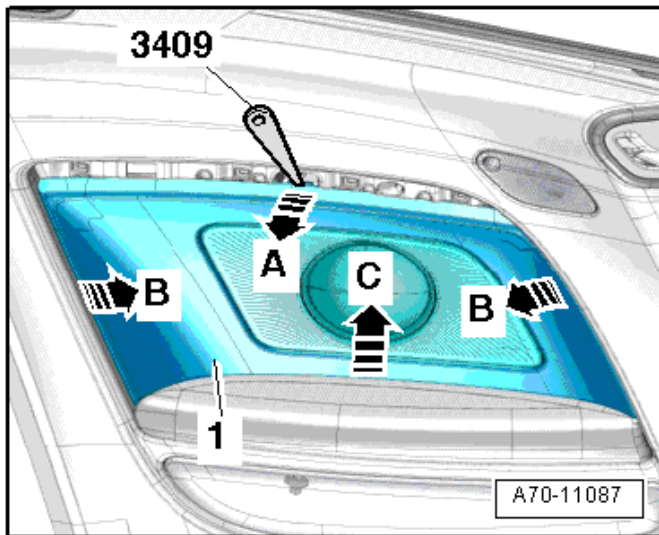

- Starting at the top, carefully unclip the side trim panel insert <1> using a clean -3409- in direction of <arrows A and B>.
- Remove the side panel insert in the direction of <arrow C>.

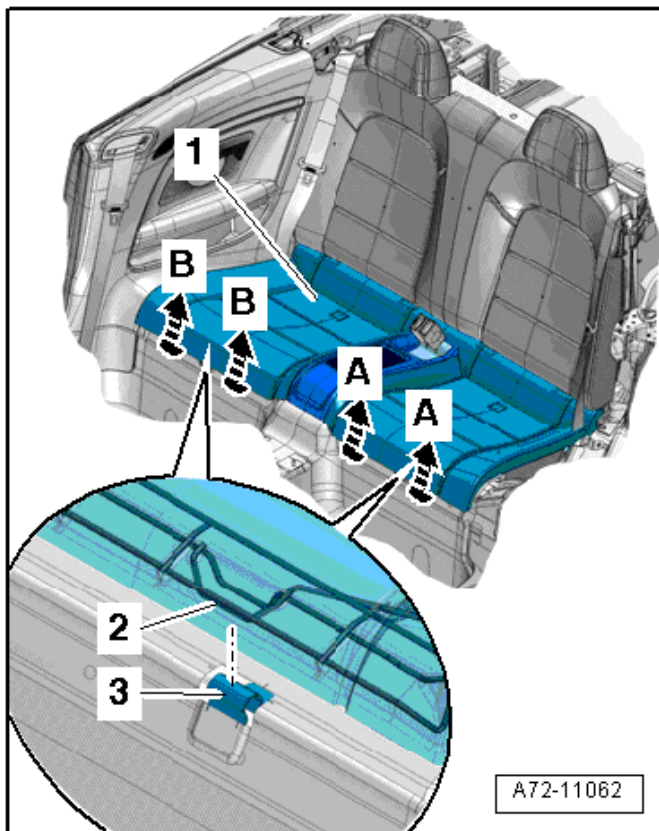

- Reach under the seat frame with both hands on one side of the seat.
- Pull the bench seat <1> up with both hands in direction of <arrows A> so the seat frame <2> on the bench seat disengages from the mountings <3>.
- Repeat the procedure on the other side of the bench seat in direction of <arrows B>.
- Vehicles with seat heating: disconnect the seat heating connector.
- Remove the bench seat from vehicle.

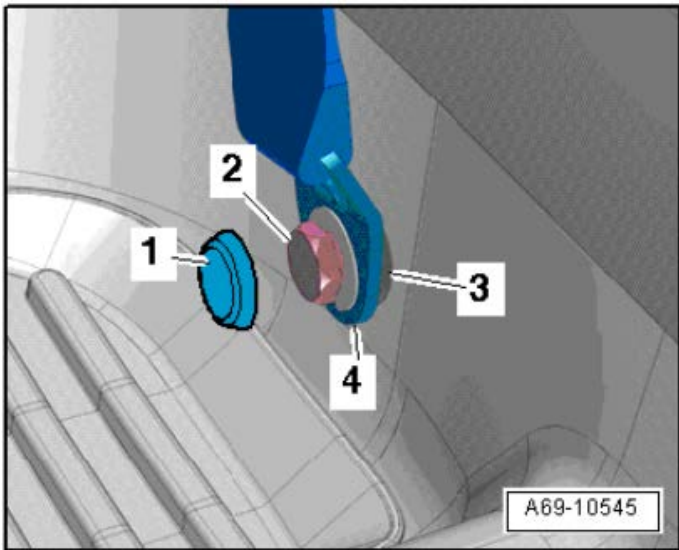

- Remove the front seat belt anchor bolt <2> after removing cap <1>.

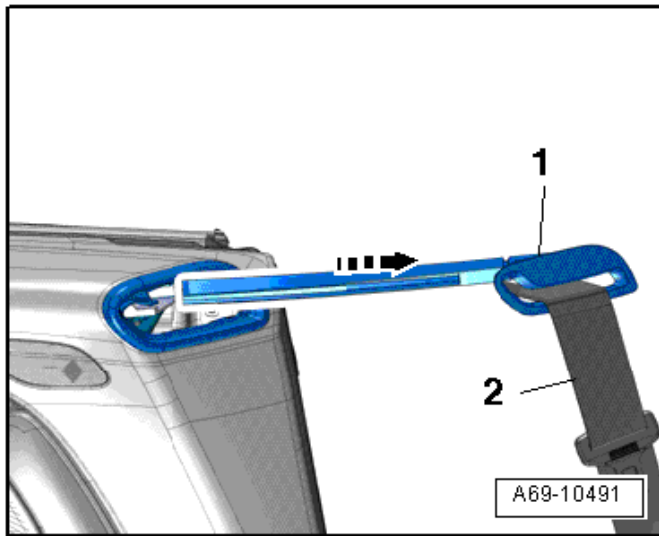

- Pull the seat belt positioning arm <1> out of the seat belt positioning motor in direction of <arrow>.
- Thread the seat belt webbing <2> with the seat belt tongue out of the seat belt positioning arm <1> and remove the positioning arm from the vehicle.

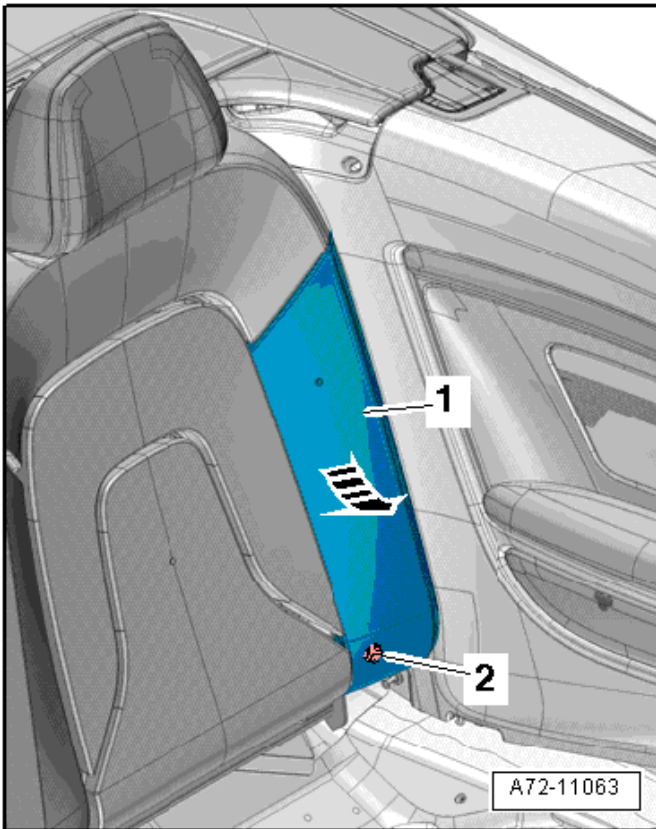

- Remove the nut <2>.
- Pull the bottom of the side upholstery <1> off the stud.
- Pull the side upholstery downward <arrow> and remove it from the vehicle.

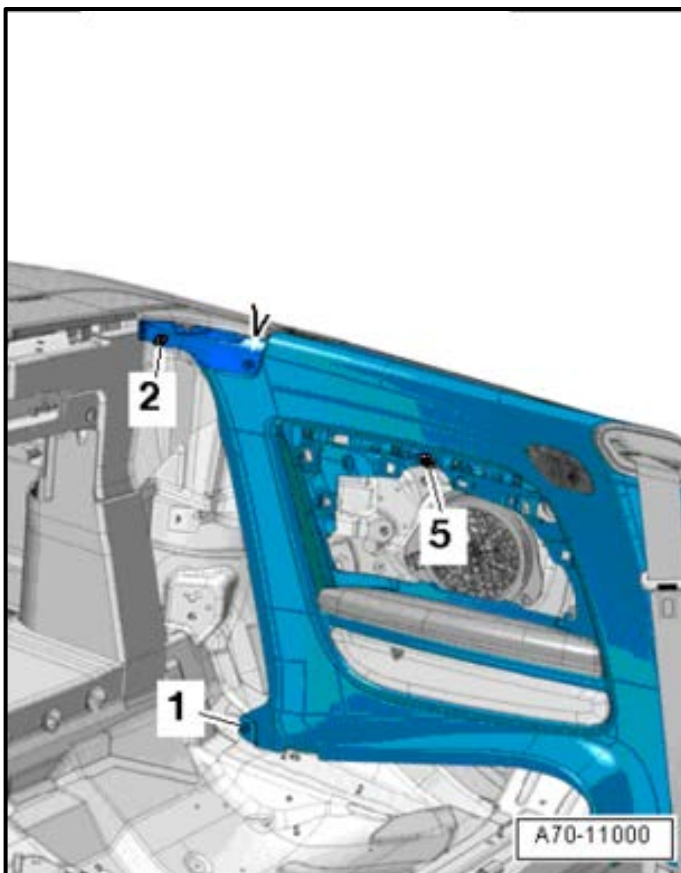

- Remove expanding clip <1> using the -80-200-.
- Open the trunk.
- Unlock the rear seat backrest and fold it forward.
- Remove bolts <2 and 5>.



- Close the trunk, move the convertible top to the position shown and turn off the ignition.

⚠ WARNING

- After approximately 6 minutes the convertible top control module will bleed the hydraulic pressure and the convertible top compartment cover could fall down uncontrolled.
- The convertible top compartment cover must be in the position shown so the weight of the cover does not allow it to close on its own once the hydraulic pressure has been bled.



- Remove bolt <1>.

ⓘ NOTE

- Passenger side is shown.
- When removing bolt <1>, a flat bladed screwdriver will need to be inserted between the body and the trim panel as illustrated. Slight pressure will need to be applied between the body and the trim panel to keep the metal thread insert <2> from spinning in the trim panel.

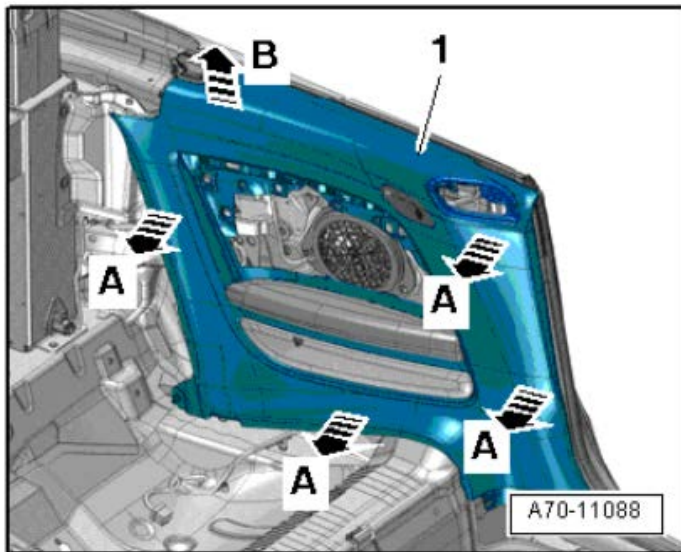

- Starting on the side and bottom unclip the side trim panel <1> in direction of <arrows A>.
- Tilt the side trim panel toward the center of the vehicle and remove in direction of <arrow B>.
- Vehicles with treble speaker: Disconnect the connector
- Remove the rear seat belt webbing from the belt guide.
- Guide the front seat belt webbing with the seat belt tongue through the side trim panel and remove the side trim panel.
- Switch the ignition on and re-open the convertible top.

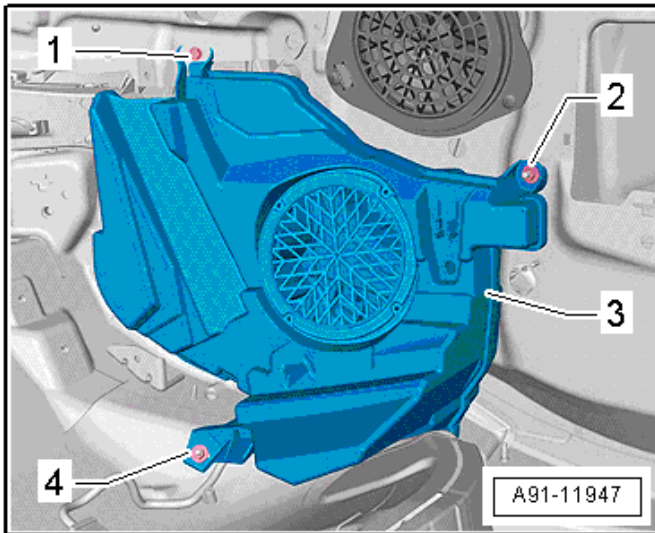

- If equipped, remove the rear subwoofer.
 - Remove the bolt <1> and the nuts <2 and 4> from the rear subwoofer <3>.
 - Unlock and disconnect the connector and then remove the subwoofer <3>.

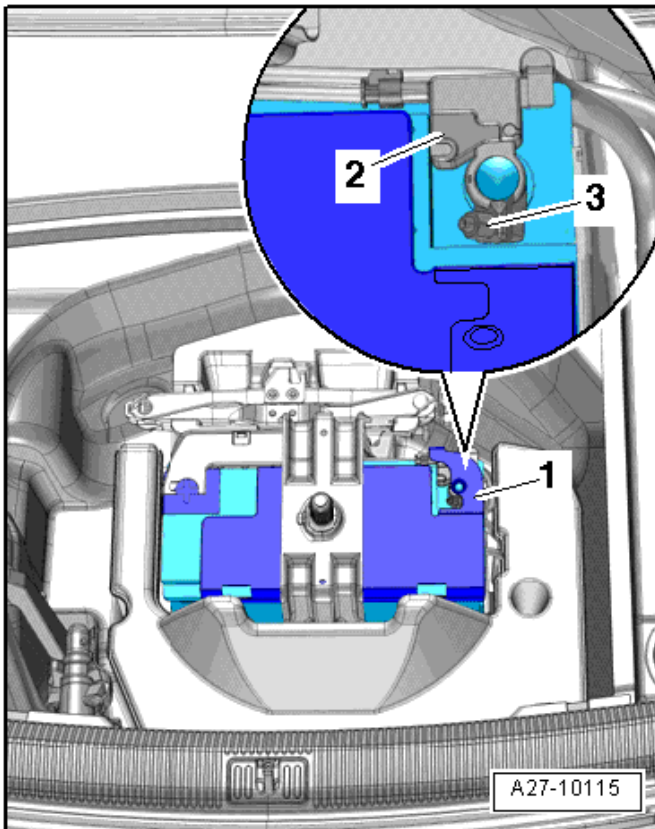

NOTE

Make sure the convertible top is in the fully opened position.

- Open the trunk.
- Lift the luggage compartment floor and engage it on the body.
- Remove the spare tire.

WARNING

Accident risk. When working on pyrotechnic components (such as airbags and belt tensioners), the battery must be disconnected with the ignition switched **ON**.

- Open the cover <1> over the battery negative terminal.
- Loosen the nut <3> several turns.
- Remove and isolate the battery ground cable terminal <2> from the battery terminal.

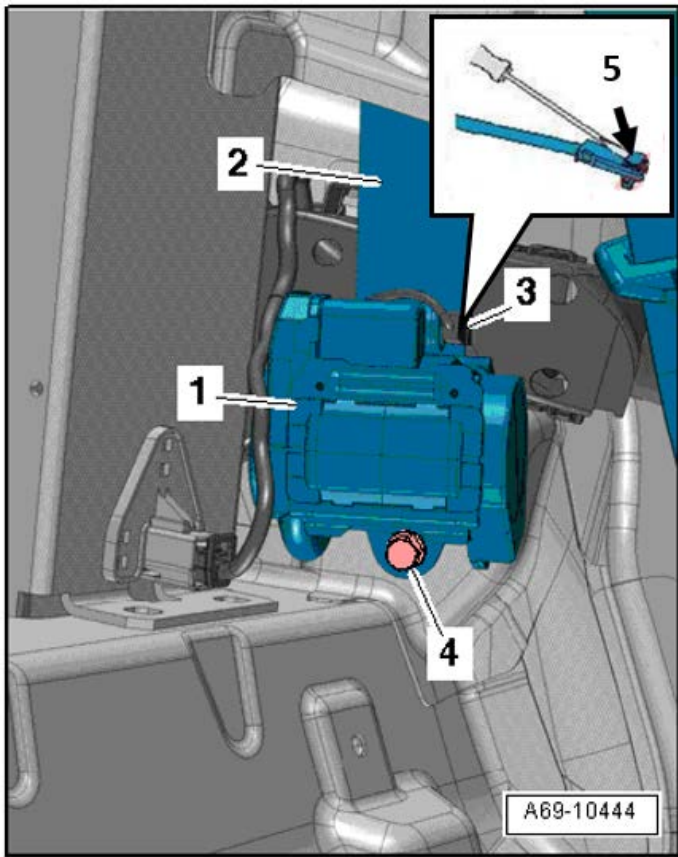

- Disconnect connector <3> using a small flat bladed screwdriver or pick tool to disengage connector lock <5>.
- Remove the bolt <4>.
- Thread the seat belt webbing <2> downward and remove the three-point seat belt <1>.
- Install the new seat belt with the anti-twist mechanism in the mount and torque the bolt <4> to 45 Nm.

Criteria	Part Number	Description
HL,HR,06,08	8F0857805C IML	Seat Belt, rear left
	8F0857806C IML	Seat Belt, rear right
HR 01	8F0857806C V04	Seat Belt, rear right
HL 07	8F0857805C IMM	Seat Belt, rear left

- Install connector <3> and engage the lock.

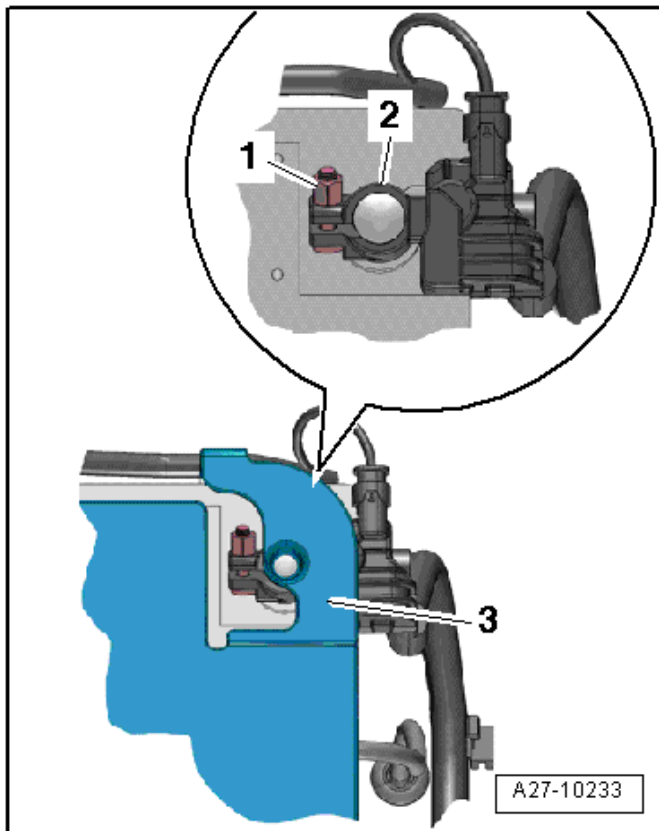

⚠ WARNING

Ignition must be ON when connecting battery. If pyrotechnic components (e.g. airbag, belt tensioner) are not repaired correctly, they may deploy unintentionally after connecting battery. There must not be anyone inside the vehicle when connecting the battery.

- Disconnect the connector <2> from the Battery Monitoring Control Module -J367-.
- Attach the battery ground cable clamp by hand to the battery negative terminal and torque the nut <1> to 6 Nm.
- Reconnect the connector to the Battery Monitoring Control Module -J367-.
- Re-install the spare tire and luggage compartment floor.
- Cycle the ignition off and back on.

ℹ TIP

Checking faults at this stage will eliminate having to remove the side trim panel(s) again if there are faults stored for the seat belt pretensioners.



- Close the trunk, move the convertible top to the position shown and turn off the ignition.

⚠ WARNING

- After approximately 6 minutes the convertible top control module will bleed the hydraulic pressure and the convertible top compartment cover could fall down uncontrolled.
- The convertible top compartment cover must be in the position shown so the weight of the cover does not allow it to close on its own once the hydraulic pressure has been bled.

- Thread the belt webbing through the body.

i TIP

Use a long hook tool to aid in threading the belt webbing up through the body. Do not hook onto the belt webbing.

- If equipped, install the rear subwoofer.
 - Install the bolt <1> and the nuts <2 and 4> and torque to 3.5 Nm.
 - Connect and lock the connector.

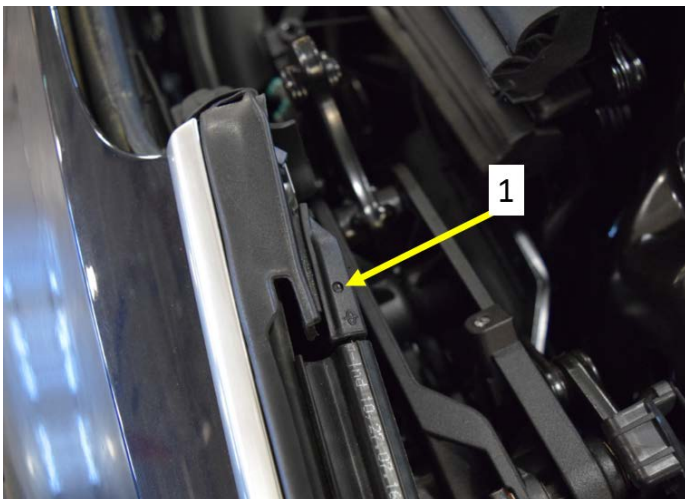
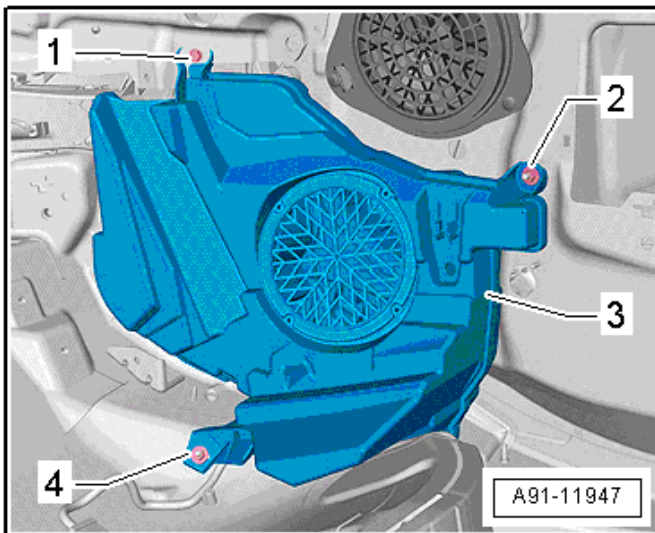

- Ensure the seal <1> is installed as shown.

ⓘ NOTE

Passenger side is illustrated.

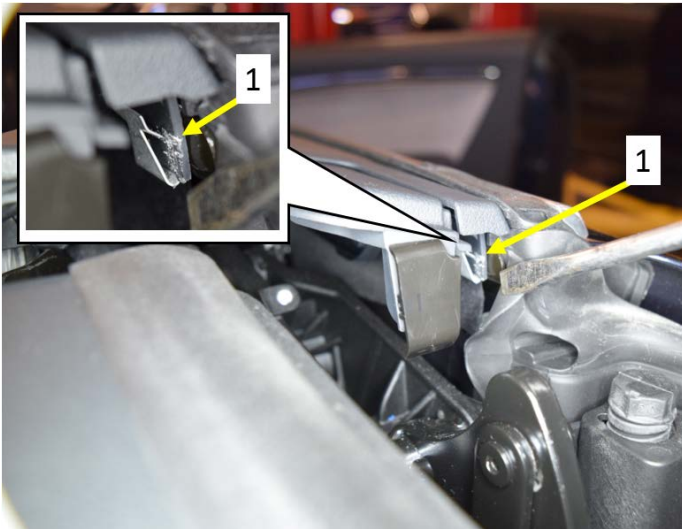

- When installing the side trim panel in the following step, ensure the tab <1> on the trim panel is installed in the clip as shown.

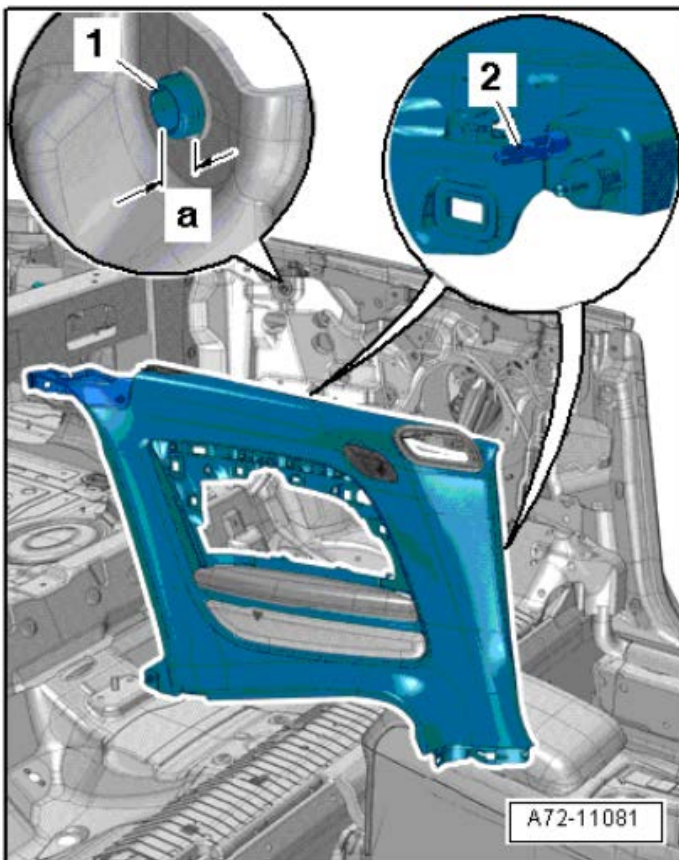

- Remove any trim clips remaining in the body using Omega Clip Tool -T40280- (or equivalent) and install into the trim panel.
- Guide the seat belt through the opening in the trim panel.

NOTE

Ensure the seat belt webbing is not twisted between the seat belt and the trim panel.

- Install the side trim panel.
 - Ensure the adjusting sleeve <1> is adjusted to 2.4 mm <dimension a>.
 - Insert the centering pins <2> on the back of the side trim panel into the holes in the body.
 - Stretch the door seal lip over the side trim.

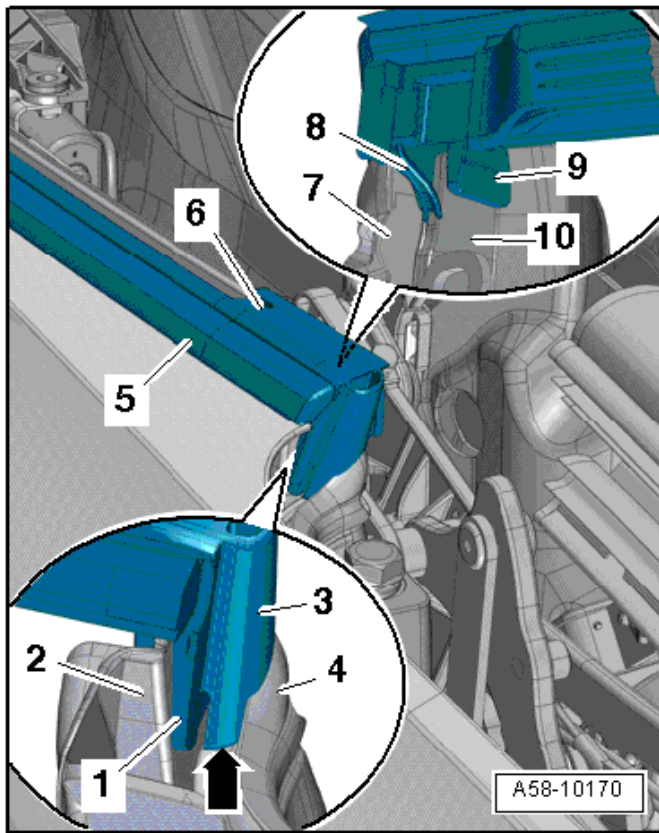

NOTE

- Water will get into the passenger compartment if the outer/inner window shaft strip and the convertible top compartment cover seal are not installed correctly.
- Verify the outer window shaft strip seals are installed correctly.
 - The end <1> of the seal must touch the outside of the convertible top compartment cover seal <2>.
 - The water drain opening <3> must be in full contact with the inside of the convertible top compartment cover seal <4 and arrow>.
 - The lug <9> on the inside of the window shaft strip must touch the outside of the window shaft strip <10> as illustrated.
 - The water drain channel <8> must touch the convertible top compartment cover seal <7> completely.

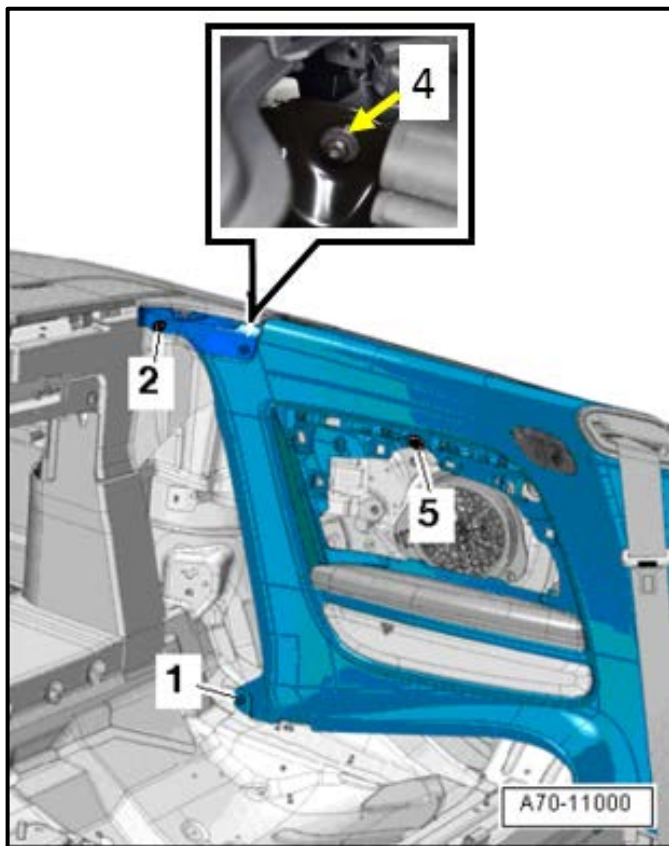

- Install bolts <2, 4 and 5> and torque to 9 Nm.
- Close rear seat backrest(s).
- Install expanding clip <1>.
- Install the side panel insert.
- Install the trim strip.

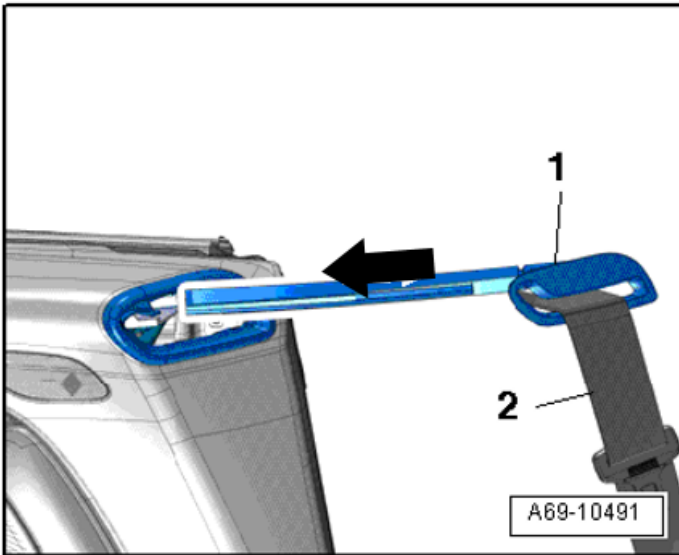

- Guide the seat belt through the seat belt positioning arm <1>.

NOTE

Ensure the seat belt webbing is not twisted between the positioning arm and the trim panel.

- Install the seat belt positioning arm <1> into the positioning arm motor in direction of <arrow>.

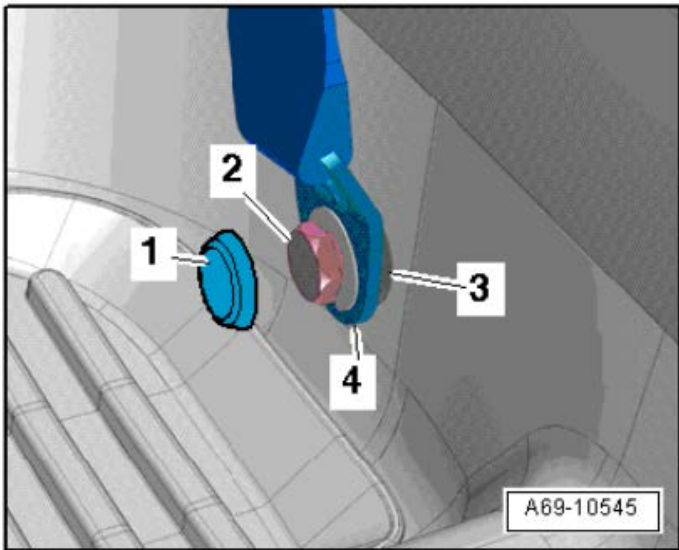

NOTE

- Ensure the seat belt webbing is not twisted between the positioning arm and the belt anchor.
- Ensure the spacer is installed on the bolt between the body and belt anchor.

- Install front belt anchor <3> and torque bolt <2> to 45 Nm.
- Install cap <1>.

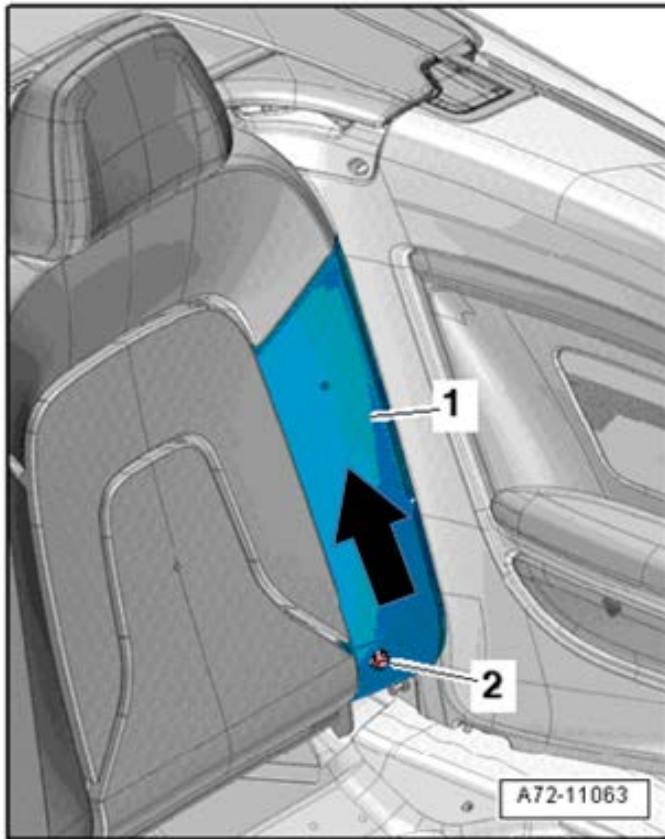

- Install side cushion <1> in direction of <arrow> and torque bolt <2> to 4 Nm.

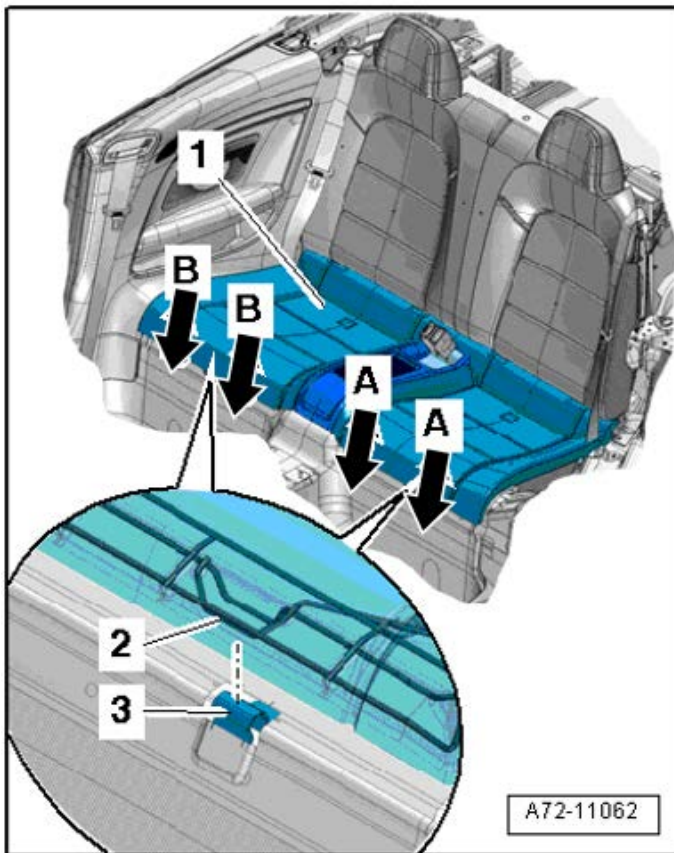

- Make sure the eyelets on the seat bench correctly fit around the connecting tube on the backrest frame.
- Press on the rear seat bench downward into the mount until it audibly engages.

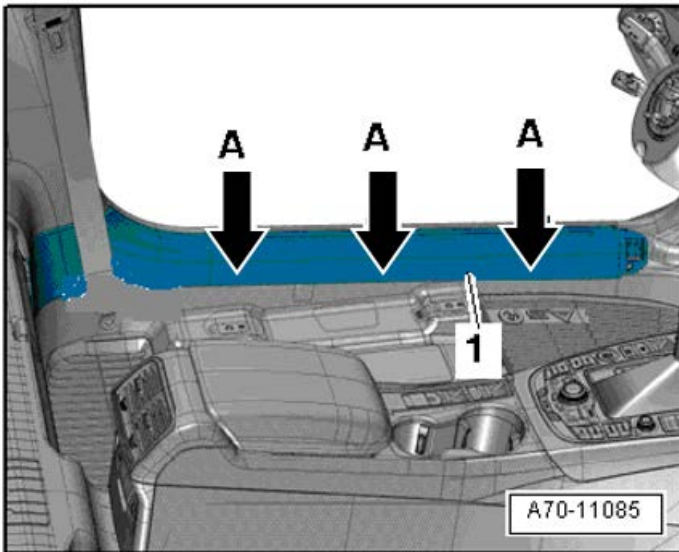

- Remove any trim clips remaining in the body using Omega Clip Tool -T40280- (or equivalent) and install into the trim panels.
- Install sill panel <1>.
- Install A-pillar trim.
- Install hood release lever if necessary.

NOTE

When installing the hood release lever, slide the clip completely into the lever and then press the lever on.

- Close rear seat backrest(s).
- Verify all door seals are installed properly.
- Set clock to local time if necessary.
- Activate the power window regulator one-touch up/down function.
- Check the DTC memories of all the control units and erase under-voltage faults if necessary.

Proceed to Section C

Section C – Campaign Completion Stamp

I certify that this campaign
has been performed in strict
accordance with the applicable
Audi repair procedure.

SAGA Code: _____
Technician: _____
Date: _____

Item#: AUD4927ENG

-OR-

Je certifie que cette
campagne de rappel a été
exécutée suivant les strictes
directives de réparation
d'Audi

Code de SAGA: _____
Technicien: _____
Date: _____

Item # AUD4927FRE

- Once the campaign has been completed, the technician should stamp the repair order.
- Stamps are available for ordering through the Compliance Label Ordering Portal.

Proceed to Section D

Section D - Parts Return/Disposal

Properly store (retain), destroy or dispose of removed parts in accordance with all state/province and local requirements, unless otherwise indicated and/or requested through the Warranty Parts Portal (WPP).

Appendix A – Warning and Safety Precautions

WARNING

General Safety Precautions when Working with Pyrotechnic Components:

- Pyrotechnic components always contain propellant that generates a gas during combustion. In some components, there is also a supply of pressurized gas to ensure this gas is generated
- This pressurized gas is stored under high pressure in a compressed gas container. Pyrotechnic components are triggered by electrical/mechanical igniters.
- Only trained personnel should perform testing, assembly and servicing work. Airbags do not have a replacement interval.
- Never check with test lamps, voltmeter or ohmmeters.
- Only check pyrotechnic components when they are installed in the vehicle using vehicle diagnosis, testing and information systems approved by the manufacturer.
- When working on pyrotechnic components and the airbag control module, disconnect the battery ground strap while the ignition is switched on. Then cover the negative terminal.
- Wait 10 seconds after disconnecting the battery.
- The ignition must be SWITCHED ON when connecting the battery. There should not be anyone inside the vehicle when doing this.
- Exception: vehicles with batteries in the passenger compartment. In this case, stay outside the range of the airbags and seat belts.
- Wash your hands after touching ignited pyrotechnic components from the restraint system.
- Do not open or repair pyrotechnic components. Use only new components to reduce the risk of injury.
- Do not install pyrotechnic components that have fallen onto a hard surface or show signs of damage.
- Discharge static electricity before handling pyrotechnic components, for example before disconnecting the electrical connector. This can be done by touching grounded metal objects such as the door striker pin.
- Install pyrotechnic components immediately after removing them from their transport packaging. If you must stop working, store the pyrotechnic component in its original transport packaging.
- Do not leave pyrotechnic components lying in the open unattended.
- Do not treat pyrotechnic components with grease, cleaning solutions or similar products.
- Do not expose pyrotechnic components to temperatures above 100 °C, even for brief periods of time.
- People in the immediate vicinity of the workplace must be protected from possible noise and projectiles.
- Pyrotechnic components can trigger unintentionally.
- In the event of deployment:
 - Single-stage inflators: allow airbag to cool down completely. Wait at least 10 minutes before handling.
- Two-stage inflators: wait for second airbag ignition. Allow airbag to cool down completely. Wait at least 10 minutes before handling.