

Reference:

ITB17-028

Date:

March 28, 2017

VOLUNTARY SAFETY RECALL CAMPAIGN 2017 QX30; DRIVER CURTAIN AIR BAG MODULE

CAMPAIGN ID #: PG7B5**APPLIED VEHICLE:** 2017 QX30 (H15)

Check Service COMM to confirm campaign eligibility.

INTRODUCTION

Infiniti is conducting a Voluntary Safety Recall Campaign on certain specific model year 2017 QX30 vehicles to replace the driver curtain air bag module. This service will be performed at no charge to the customer for parts or labor.

IDENTIFICATION NUMBER

Infiniti has assigned identification number PG7B5 to this campaign. This number must appear on all communications and documentation of any nature dealing with this campaign.

DEALER RESPONSIBILITY

It is the dealer's responsibility to check Service COMM. for the campaign status on each vehicle falling within the range of this voluntary safety recall campaign which for any reason enters the service department. This includes vehicles purchased from private parties or presented by transient (tourist) owners and vehicles in a dealer's inventory. **Federal law requires that new vehicles in dealer inventory which are the subject of a safety recall must be corrected prior to sale. Failure to do so can result in civil penalties by the National Highway Traffic Safety Administration.** While federal law applies only to new vehicles, Infiniti strongly encourages dealers to correct any used vehicles in their inventory before they are retailed.

Infiniti Bulletins are intended for use by qualified technicians, not 'do-it-yourselfers'. Qualified technicians are properly trained individuals who have the equipment, tools, safety instruction, and know-how to do a job properly and safely. **NOTE:** If you believe that a described condition may apply to a particular vehicle, DO NOT assume that it does. See your Infiniti retailer to determine if this applies to your vehicle.

REQUIRED SPECIAL TOOL (J-52352)

Quick Scan Tool (J-52352)

- Each retailer has been shipped one Quick Scan Tool (J-52352).
- Additional tools can be obtained from Tech•Mate at 1-800-662-2001.



Figure A1

SERVICE PROCEDURE

New Module Registration

1. Register the new module serial number as follows.
 - The new module is listed in **PARTS INFORMATION**.

- a. Attach the quick scan tool (J-52352) to your CONSULT PC USB port.



Figure A2

- b. On the left side of the ASIST main menu, select Tech Support Info, then Inventory Vehicle Actions.

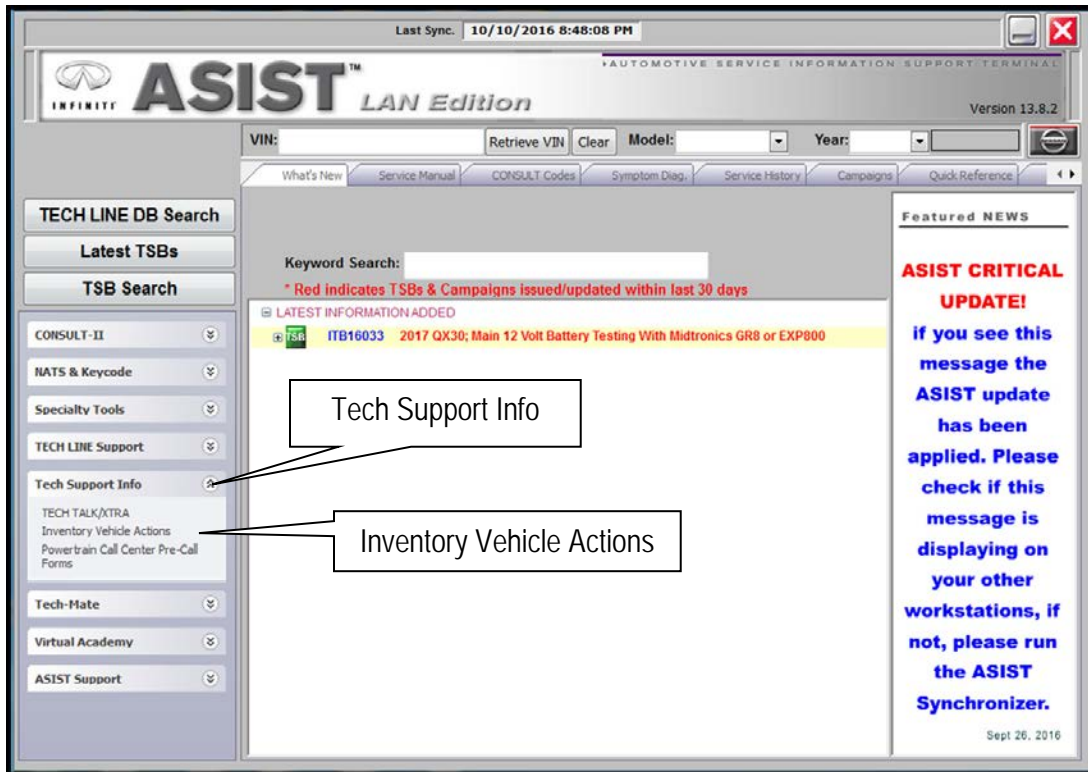

Figure A3

- c. Select **CLICK HERE** (Air Bag to VIN Registration).



Figure A4

d. Use the quick scan tool to scan the bar code (VIN) on the B-pillar label.

- Wipe any dirt/debris from the bar code before scanning.

NOTE:

- Some labels may not scan quickly.
- Hold the scan tool approximately 6 inches away from the label.
- Hold the trigger down until the label is read (this may take several seconds).



Figure A5

- The VIN will automatically populate (see Figure A6).
- If needed, the VIN can be entered manually.

Airbag to VIN Registration

11/28/2016 1:36:32 PM

Please enter/scan the VIN and Airbag Inflator Serial Number

Dealer Code ■ ■ ■ ■

Key Number ■ ■ ■

VIN

Airbag Serial Number **Submit**

Step f; see next page
(Select **Submit** after both fields are populated)

Figure A6

- e. Use the quick scan tool to scan the bar code (serial number) on the new module.
- Remove the module from the shipping box and locate the bar code label (see Figure A7 and A8).
 - Hold the scan tool approximately 6 inches away from the label.
 - The serial number will automatically populate (see Figure A6 on previous page).

NOTE: If needed, the serial number can be entered manually.

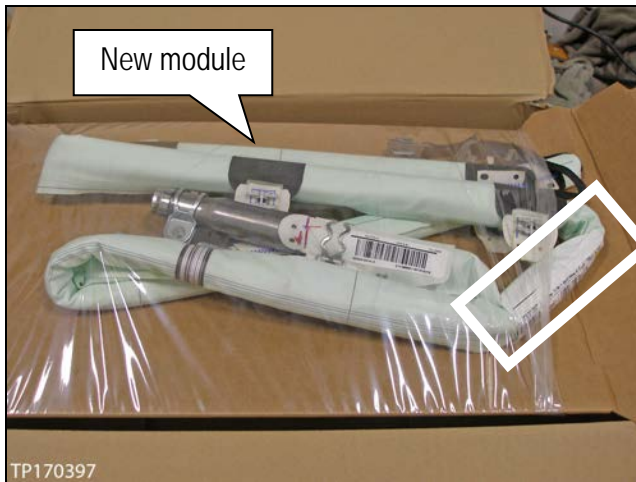

Figure A7



Figure A8

- f. Select **Submit** on the ASIST screen (see Figure A6 on the previous page).

Removal: Driver Curtain Air Bag Module

NOTE:

- Driver curtain air bag module removal and installation is the same for sunshade and non-sunshade equipped QX30 vehicles.
- Use protective covering for all interior surfaces as needed while performing this procedure.
- Make sure hands/gloves are clean when working on the vehicle's interior.
- Store all removed parts in a clean area where they will not get damaged.
- Return the used/non-deployed air bag module using the instructions at the end of this bulletin.

IMPORTANT: Follow all warnings, cautions, and notes in the Electronic Service Manual (ESM) when working on or near a Supplemental Restraint System (SRS), such as an air bag.

1. Turn the ignition ON, engine OFF.
2. If equipped: Fully open the sunshade.
3. Fold down both rear seatbacks, and then recline the front seatbacks rearward as much as possible.
4. Turn the ignition OFF.

5. Disconnect the negative battery terminal cable.
 - a. Remove the hood release cable from the battery cover.
 - b. Remove the battery cover by pulling forward, and then lifting up.
 - c. Unfasten the negative battery cable.
 - Before servicing the SRS, turn the ignition switch OFF, disconnect the negative battery cable and wait at least three (3) minutes.
 - For approximately 3 minutes after the negative battery cable is removed, it is still possible for the air bag and seat belt pretensioner to deploy. Therefore, never work on any SRS connectors or wires until at least 3 minutes have elapsed.
 - d. Wrap the battery post or negative battery cable end with electrical tape.

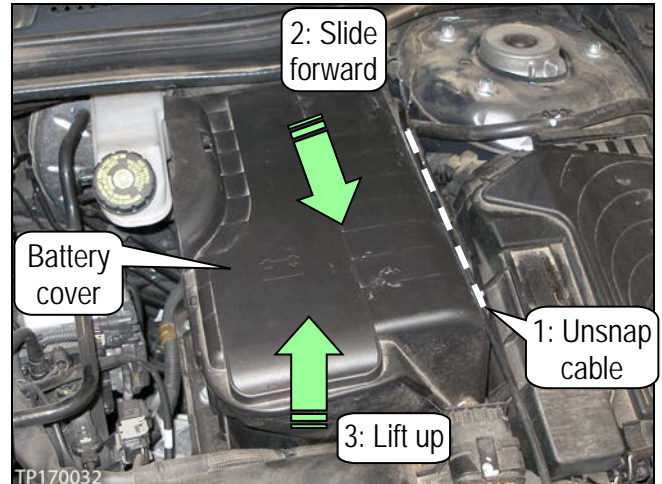

Figure 1



Figure 2

6. Remove the tonneau cover assembly.



Figure 3

7. Detach both rear pillar garnishes.
 - a. Pull off the rear door welts in the area of the rear pillar garnishes.
 - b. Remove the cap with a suitable pry tool.

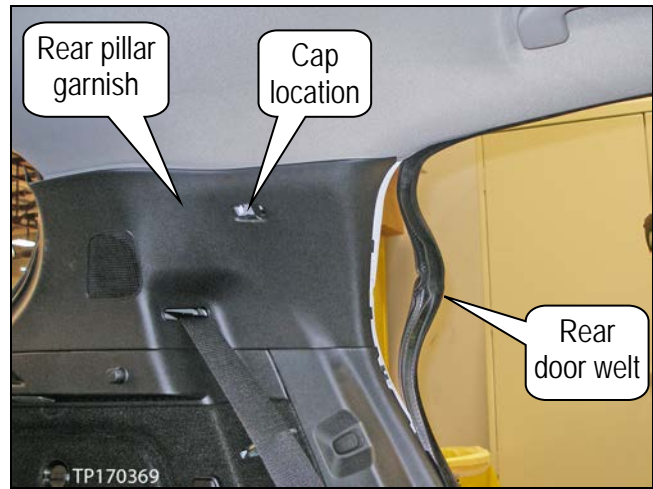

Figure 4

- c. Unfasten all rear pillar garnish clips and pawls, starting at the rear (see Figure 5 and 6).

 = clip location

 = pawl location

- If equipped: Disconnect the rear pillar squawkers (speakers).

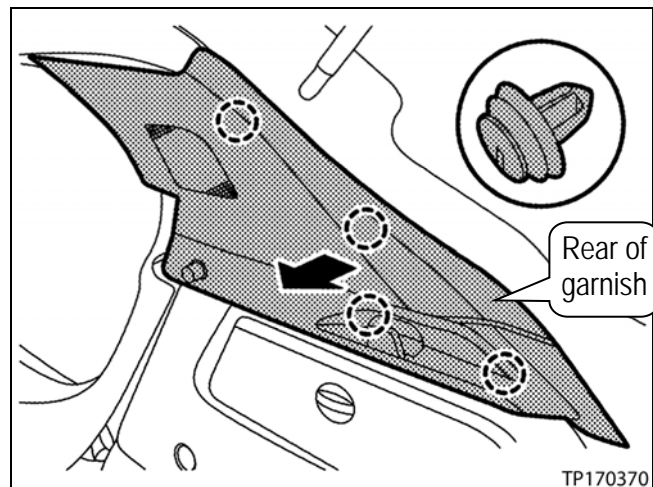

Figure 5

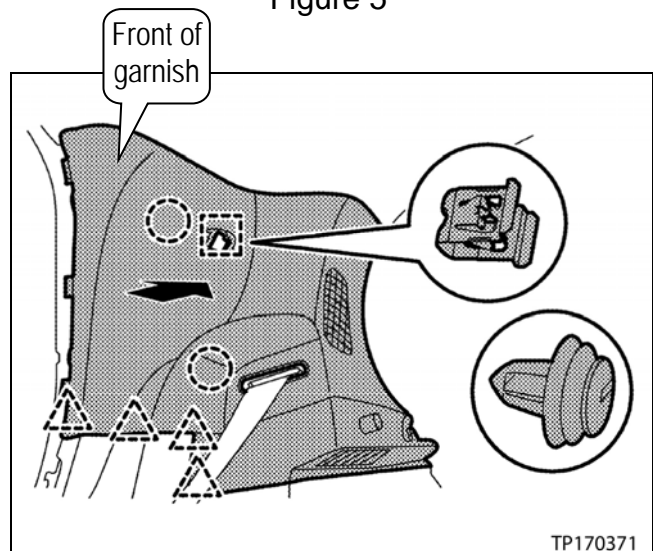

Figure 6

- d. Let the finishers rest at the sides of the luggage floor area.
 - Disconnect the luggage room lamp electrical connector as needed.

8. Disconnect the two (2) electrical connectors located behind the rear pillar garnish RH.

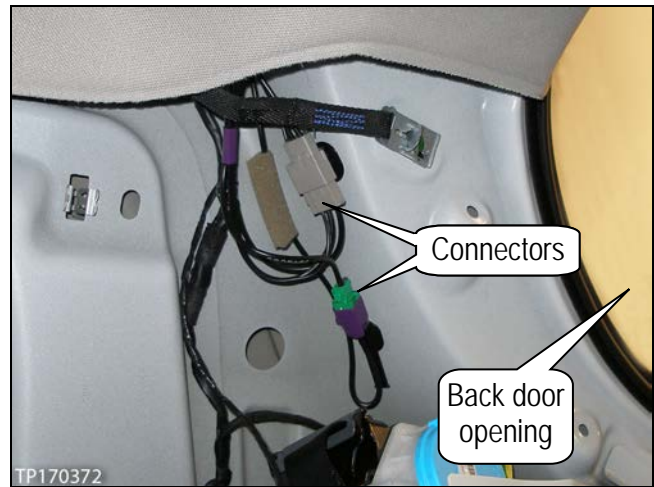

Figure 7

9. Remove all four (4) assist grips.
 - a. Carefully remove the covers with two suitable pry tools.

 = pawl location

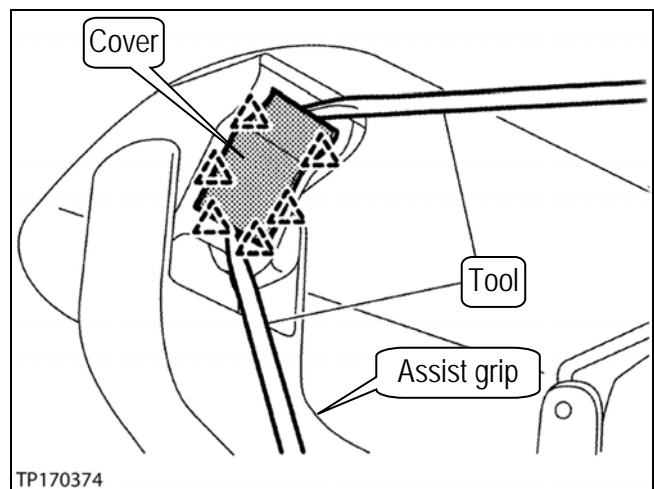

Figure 8

- b. With both covers removed, pinch in the metal clips, and then pull off the assist grip.

NOTE: Reinstall the metal clips in the assist grips before reinstalling the assist grips.

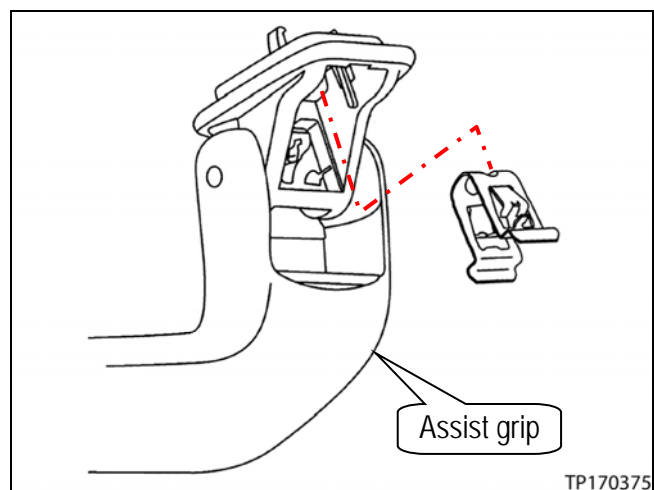

Figure 9

10. Remove both front pillar garnishes.
- Pull down the front door welt away from the front pillar garnish (see Figure 10).



Figure 10

- Remove the front pillar garnish cap with a suitable plastic trim tool.
 - See Figure 11 for cap location.
- Unsnap the clips by pulling away from the pillar, and then remove the front pillar garnish by pulling upward.
 - See Figure 11 and 13.

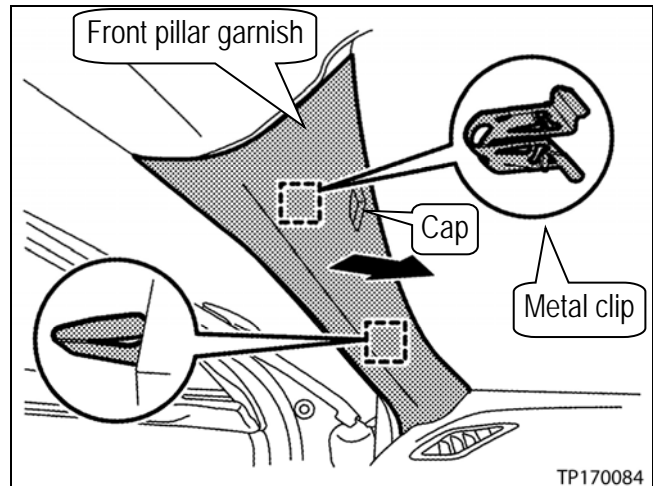

Figure 11

WARNING: The metal clip needs to be installed in each front pillar garnish before the front pillar garnishes are installed in the vehicle (see Figure 12).



Figure 12

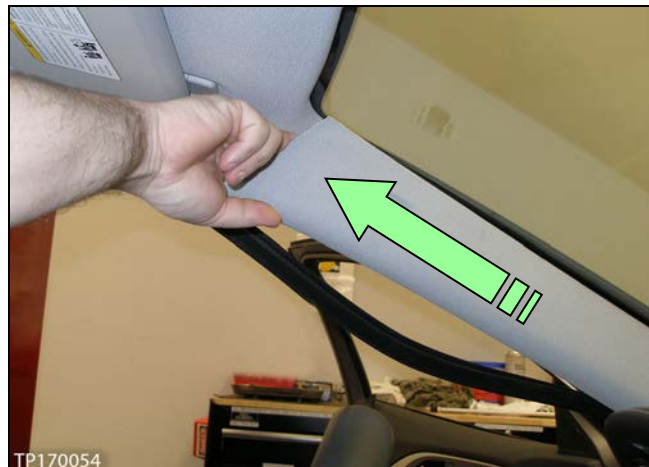

Figure 13

11. Disconnect the two (2) electrical connectors and 2 clips behind the front pillar garnish LH.

- One clip fastens the harness, the other holds one of the connectors (see Figure 14).

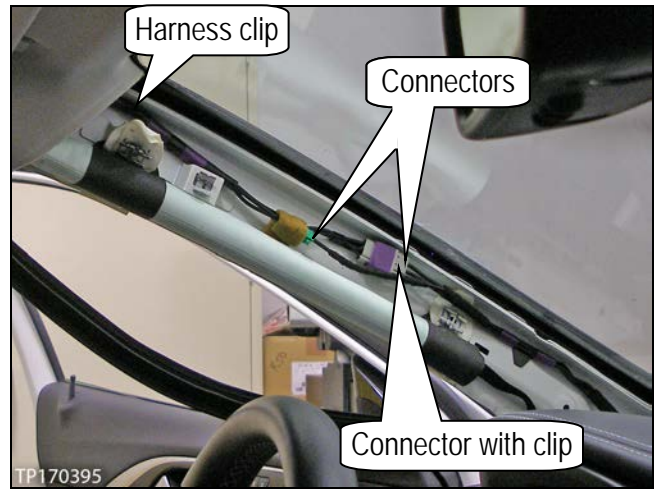

Figure 14

12. Remove both sun visors.

a. Using a suitable tool, unfasten, and then remove the sun visor cover (see Figure 15).

- To remove the sun visor cover, the sun visor may need to be extended (see Figure 16).

b. Carefully unfasten/remove the metal clip (see Figure 16 for clip location).

NOTE: If a metal clip falls inside where it fastens to the roof, it can be retrieved with a magnet after the headlining has been removed.

c. Position, and then rotate the sun visor and its pivot mounting together as shown in Figure 17.

NOTE: Reinstall the metal clips in the sun visors before reinstalling the sun visors.

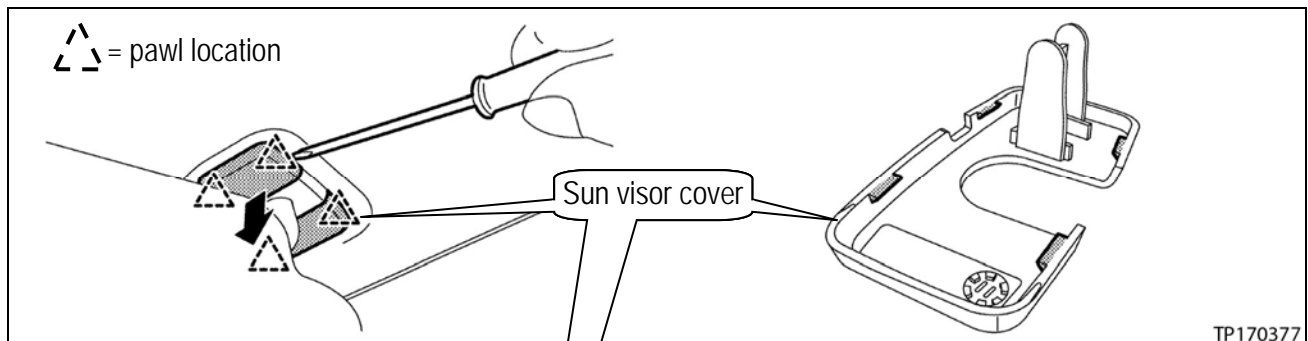

Figure 15



Figure 16



Figure 17

13. Unfasten, and then remove both sun visor holder covers (see Figure 18 and 19 below).

 = pawl location

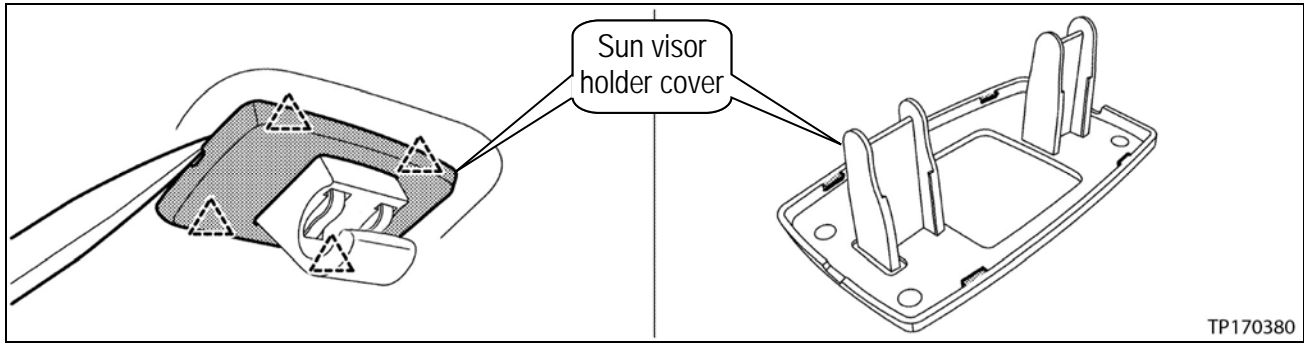

Figure 18

Figure 19

14. Carefully remove the metal clips, and then remove the sun visor holders.

- At this time, reinstall the metal clips in the sun visor holders.

NOTE: If a metal clip falls inside where it fastens to the roof, it can be retrieved with a magnet after the headlining has been removed.

 = clip location

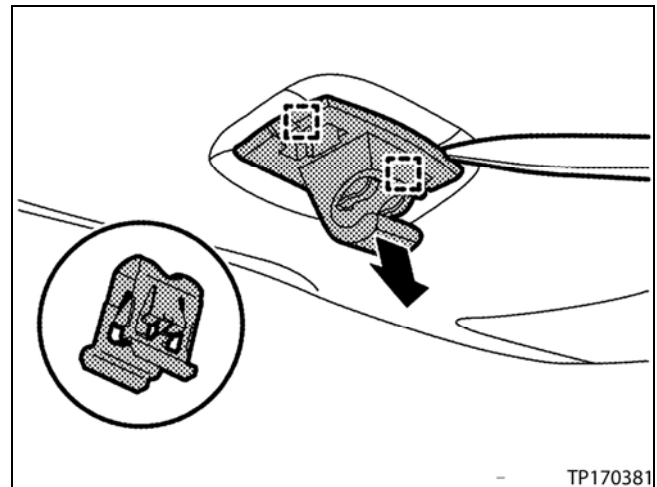

Figure 20

NOTE: Do not remove the sun visor holder electrical contacts.

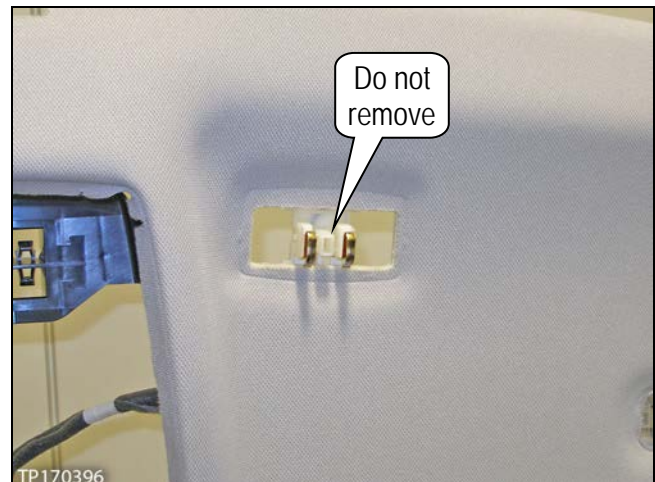

Figure 21

15. If equipped: Unfasten the anti-theft alarm system/emergency call system button group from the light & rain sensor cover A, and then unfasten/remove the light & rain sensor cover A.

- The anti-theft alarm system/emergency call system button group does not need to be disconnected/removed.

 = pawl location

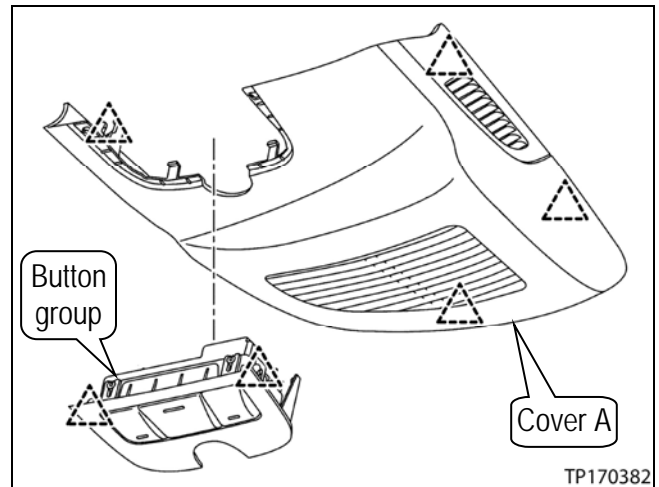

Figure 22

16. Disconnect the light & rain sensor electrical connector.

- This electrical harness is part of the headlining. It will be removed with the headlining.

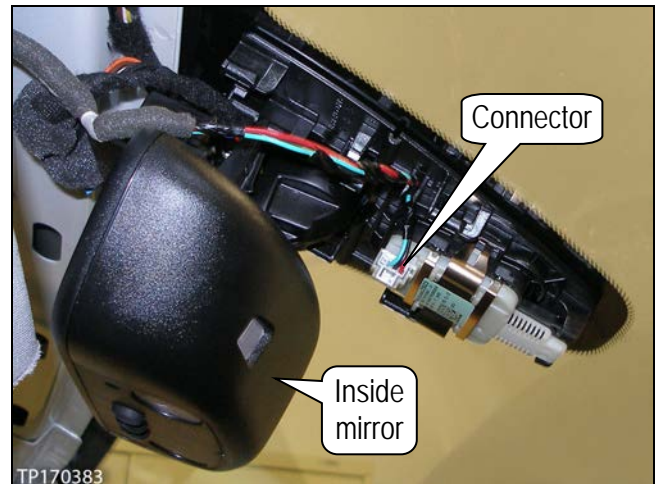

Figure 23

17. Unfasten the overhead control panel (see Figure 24 below).

- Insert a suitable plastic trim/pry tool, and then press on the spring loaded part.
- With the spring loaded part pressed inward, lower the "pry tool" side of the overhead control panel.
- Pull the overhead control panel toward the rear of the vehicle.
- Disconnect its electrical connectors, and then remove the overhead control panel.

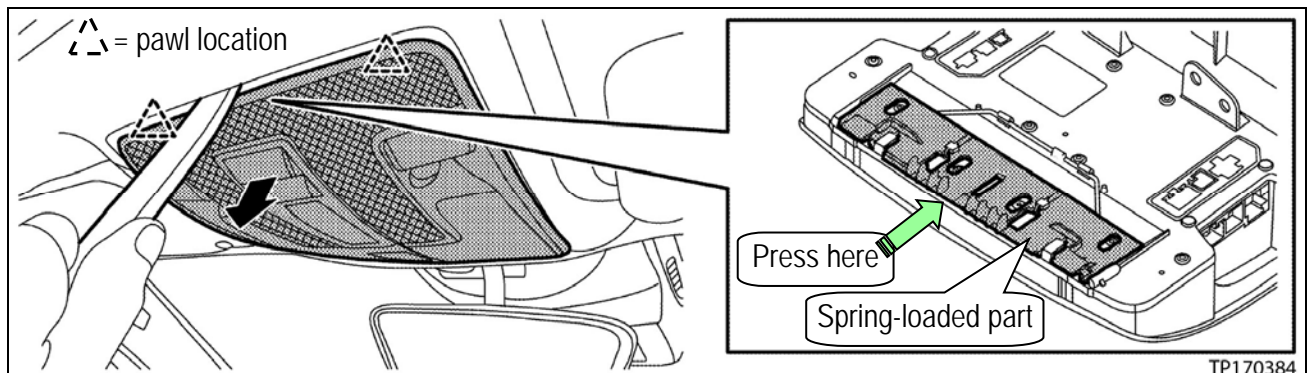

Figure 24

18. Unfasten the headlining's clip, pawls, and dual-lock fasteners from the roof.

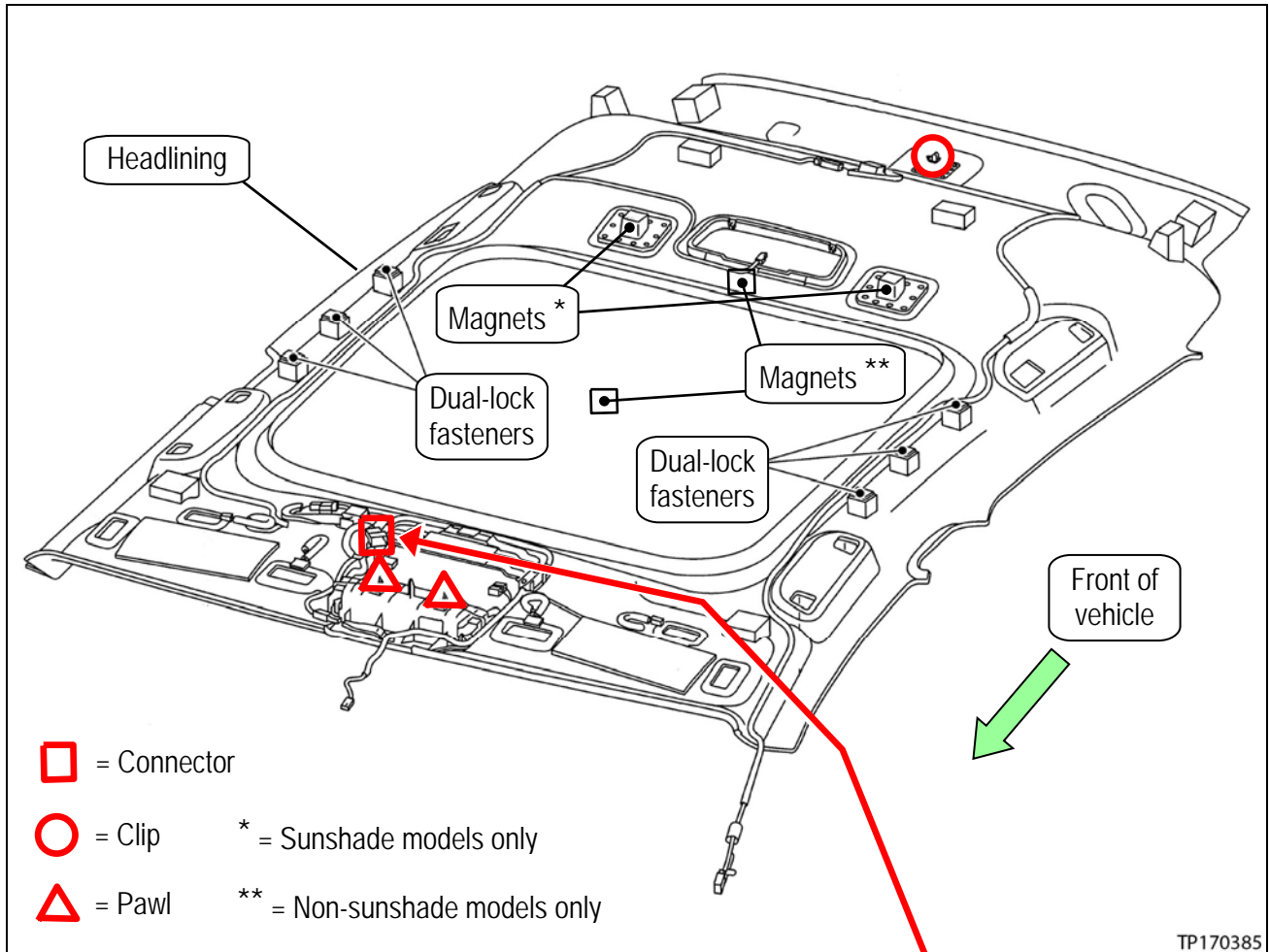

Figure 25

19. Disconnect the electrical connector located on the top side of the headlining.

- Access the electrical connector through the overhead control panel's opening.

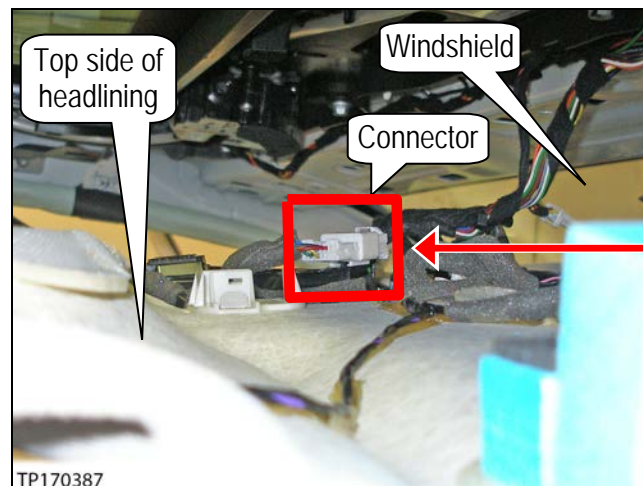

Figure 26

20. Carefully lift up the side of the headlining over the top edge of the center pillar upper garnish.
 - Perform the same procedure on the other side of the headlining.



Figure 27

21. Unfasten the magnets, and then carefully lower and remove the headlining through the back door opening.
 - See previous page, Figure 25, for magnets location.

CAUTION: Use two persons, and be careful when removing the headlining.

22. Disconnect the driver curtain air bag module electrical connector.

CAUTION:

- When removing the driver curtain air bag module electrical connector, insert a suitable tool wrapped with tape, lift the lock, and then remove the connector.
- When installing, place the connector with the lock raised, and then push the lock into the connector.
- After installing the connector, make sure the lock is pushed in securely.

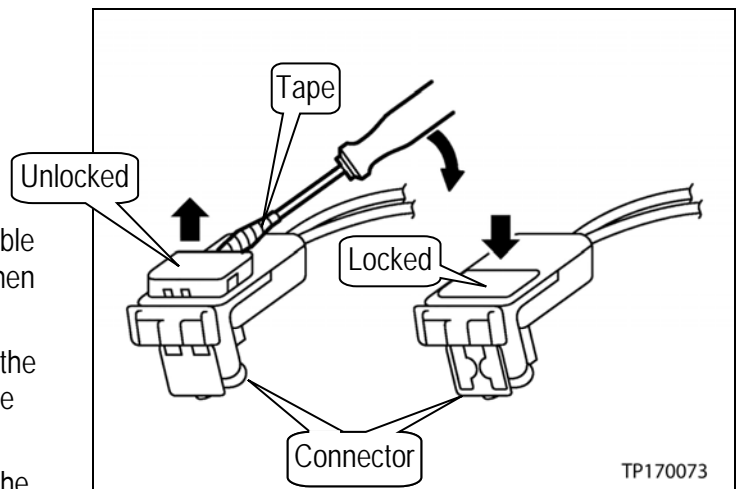

Figure 28

23. Remove the curtain air bag module T25 TORX® fixing screw.

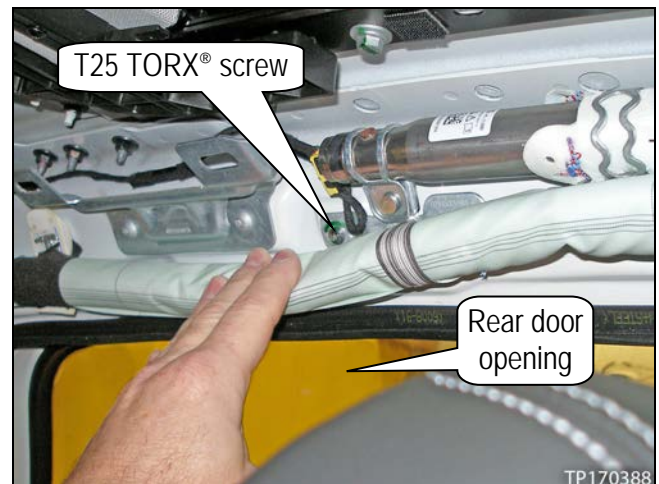

Figure 29

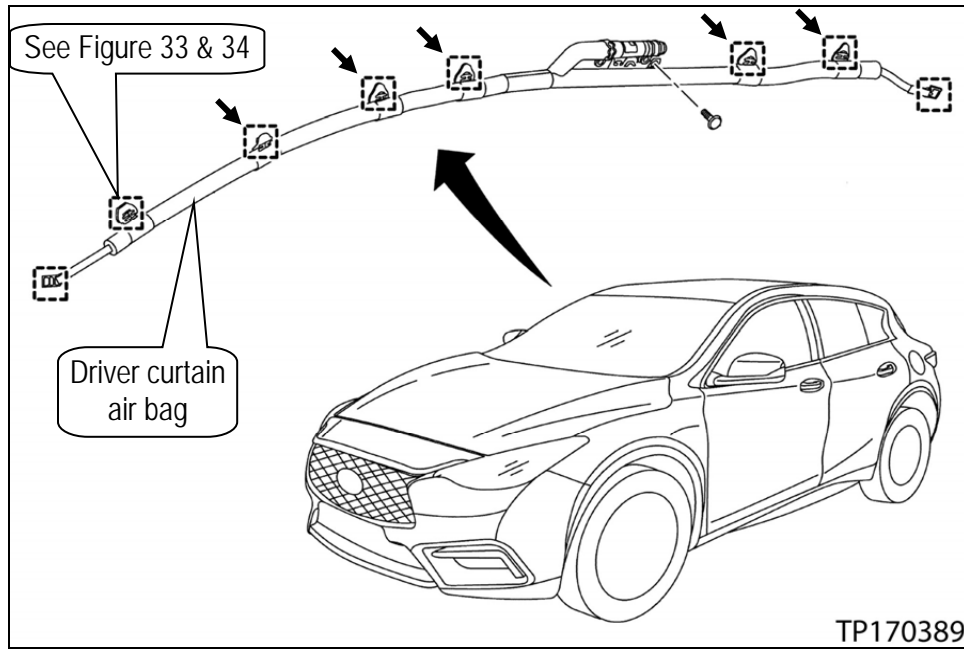

Figure 32

25. Unfasten the remaining clips.

- a. Insert a suitable tool (such as a thin flat blade screwdriver) in the clip's left hole, press inward, and then partially pry out (see Figure 33).

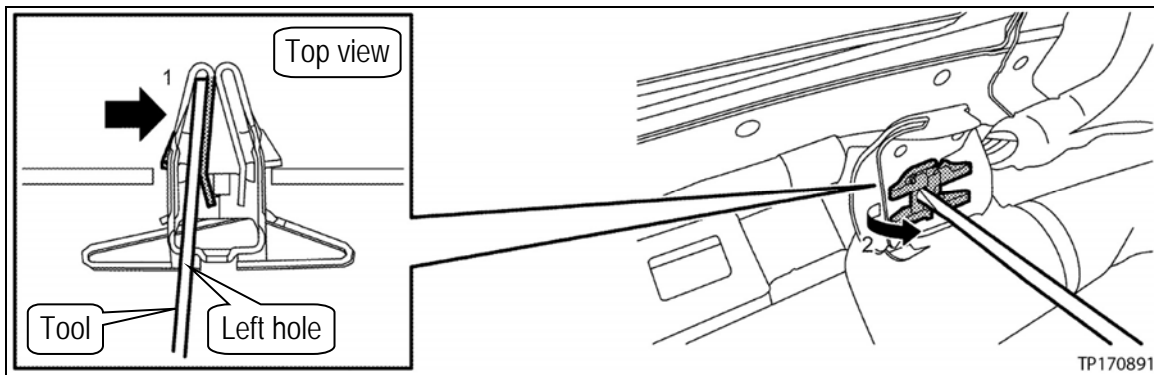

Figure 33

- b. Insert the suitable tool in the clip's right hole, press inward, and then pry out to fully release the clip (see Figure 34).

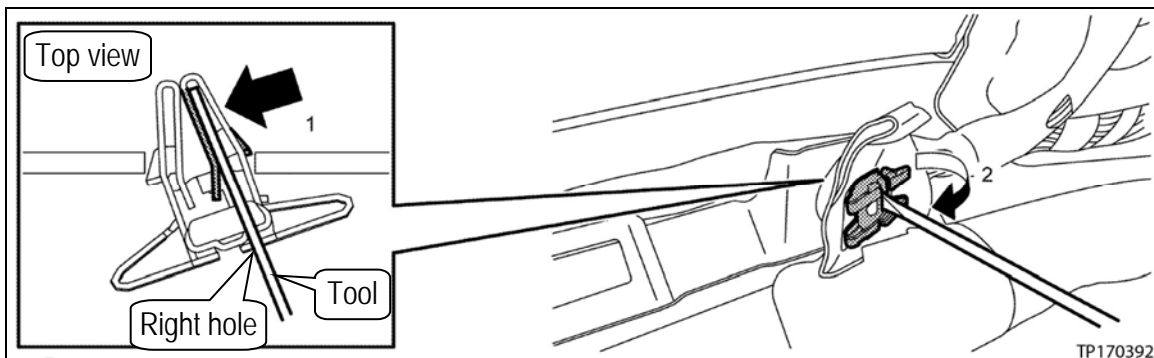

Figure 34

26. Unhook the bracket sprouting hook, and then remove the driver curtain air bag module.



Figure 35

Installation: Driver Curtain Air Bag Module

1. Install the new driver curtain air bag in reverse order of removal.
 - See **PARTS INFORMATION**.
 - T25 TORX® fixing screw torque: 6.0 N•m (0.61 kg-m, 53 in lbs)
 - Make sure all harnesses and connectors are properly routed and placed.
 - Reinstall the metal clips in the assist grips, sun visors, and sun visor holders before reinstalling them.

WARNING: The metal clips need to be installed in each front pillar garnish before the front pillar garnishes are installed in the vehicle (see page 10).

2. Remove the electrical tape, and then connect the negative battery terminal cable.

PARTS INFORMATION

DESCRIPTION	PART #	QUANTITY
MODULE ASSY-CURTAIN AIR BAG, LH (driver curtain air bag module)	985P1-5DC0A	1

NOTE: Make sure to return the removed (old / non-deployed) air bag using the return instructions on the next page.

CLAIMS INFORMATION

Submit a Campaign (CM) line claim using the following claims coding:

"CM" ID #: PG6BN

CAMPAIGN (CM) ID #	DESCRIPTION	OP CODE	FRT
PG7B5	Replace Driver Curtain Air Bag Module	PG7B50	1.5 hrs



Driver Curtain Air Bag Module Return Instructions

NOTE: DO NOT DEPLOY THE USED/NON-DEPLOYED AIR BAG MODULE REMOVED FROM THE VEHICLE.

Returns via YRC Reverse Logistics (for non DDS dealers)

Packaging Instructions

NOTE: Individuals preparing hazardous material ('Hazmat') shipments are required to be trained in accordance with the Code of Federal Regulations, Title 49, section 172.704.

1. Place the used/non-deployed air bag module from the vehicle in the carton that the new air bag module was received in. Be sure to package the used module the same way as the new module. Include any packing material that was used to ship the new module in the carton with the used module.
2. Seal the carton with 3" clear tape across the flaps and along the edges to securely close the carton.
3. Verify that the Class 9 hazardous material diamond, UN ID (UN3268), and the proper shipping name (safety devices) are still clearly visible on the carton and are not covered or obstructed in any way...



Required markings:

- | | |
|--------------------------------------|-------------------------|
| 1. Transportation information | 4. ID number |
| 2. UN specification package markings | 5. Proper shipping name |
| 3. Labels | |

4. Write on top of the carton: "OX30 Campaign".

Shipping Instructions

NOTE: Please accumulate a minimum of 10-15 air bag modules prior to contacting the YRC Reverse Logistics call center to arrange for the pick-up of the modules.

1. Call the YRC Reverse Logistics call center at 1-800-357-9199 and tell the operator that you need to return QX30 air bag modules to your servicing PDC.
2. Provide the call center with the name, address and telephone of your servicing PDC.
3. Provide your dealership name, address and telephone number.
4. Provide the number of air bag modules being returned and the total weight.
5. The YRC Reverse Logistics team will fax/email you a copy of the completed Bill of Lading and shipping labels for the shipment.
6. The YRC Reverse Logistics call center will notify the local YRC terminal to pick up the air bag modules at your dealership.
 - Please do **NOT** call the local YRC terminal to schedule the pick-up.
7. Place the packaged air bag modules and completed Bill of Lading aside for pick up by the carrier.

Returns via DDS

Packing Instructions:

NOTE: Individuals preparing hazardous material ('Hazmat') shipments are required to be trained in accordance with the Code of Federal Regulations, Title 49, section 172.704.

1. Place the used/non-deployed air bag module from the vehicle in the carton that the new air bag module was received in. Be sure to package the used module the same way as the new module. Include any packing material that was used to ship the new module in the carton with the used module.

NOTE: The carton must be in like new condition.

2. Seal the carton with 3" clear tape across the flaps and along the edges to securely close the carton.
3. Verify that the Class 9 hazardous material diamond, UN ID (UN3268), and proper shipping name (safety devices) are still clearly visible on the carton and are not covered or obstructed in any way.



Required markings:

- | | |
|--------------------------------------|-------------------------|
| 1. Transportation information | 4. ID number |
| 2. UN specification package markings | 5. Proper shipping name |
| 3. Labels | |

4. Write on top of the carton "QX30 Campaign".

Bill of Lading Instructions (refer to example on page 24):

Use the blank Bill of Lading on page 25 and enter the following:

1. Servicing PDC name, address & telephone number.
2. Date of the shipment.
3. Dealership name and address as indicated on the sample Bill of Lading.
4. Number of packages being shipped on line 1.
5. Total weight of the packages being shipped on line 1.
6. Total number of packages being shipped.
7. Total weight of the packages being shipped.
8. Print the name of the Hazmat trained/certified employee and have him/her sign as shown on sample Bill of Lading.
9. Print the name of the DDS carrier that will be transporting the air bag modules back to your servicing PDC.

Shipping Instructions:

Place the packaged air bag cartons and completed Bill of Lading in DDS delivery area for DDS driver pick up.

