

**Campaign code.**  
L73X-R.01.17

**Campaign description.**  
Evap system upgrade

**Model.**  
Aventador Coupe and Roadster.

**Model year.**  
From 2012 to 2017

**Special or Limited Versions.**  
50° Anniversario, Miura Homage, Pirelli Edition; Super Veloce, Aventador J and the projects internally denominat-ed “One-shot”: Veneno Coupè and Roadster whose tech-nology derived from Aventador models.

**Markets.**  
All.

**VIN identification**  
From CLA00091 to HLA05571

**Warning:** before starting with the repair, log to the War-ranty portal and check through VIN Info:

- The vehicle is effectively involved by these bulle-tin instructions; some cars may not be included even when they are in the VIN range.
- The procedure identified by a letter (e.g. A, B or C....etc. whose differences are explained below in this bulletin), taking care to order and use the parts corresponding to the assigned procedure.

**Example**

VIN 17 DIGIT VIN	Model MODEL NAME	Warranty Start Date DD/MM/YYYY	Warranty End Date DD/MM/YYYY
<b>Total days of workshop repairs: 0</b>			
Prior activated CPO list			
CPO	Validity months	Classification	Mileage
Insertion date	Approval date	Start date	Expire date
Claim status			
<input type="button" value="Previous"/> <input type="button" value="Page"/> <input type="button" value="Next"/>			
Available Campaigns			
Campaign Code	Campaign Type	Procedures	Campaign Starting Date
PDF	AV	CAMPAIGN NAME	DD/MM/YYYY



**Note**  
 Procedure A will be available only when the instructions require to carry out a preliminary control to determine whether or not a vehicle needs to be updated.

**Information to the field**  
 As a result of continuous product monitoring, Automobili Lamborghini Spa has found that on some cars in case of

fuel tank heavily overfilled and particular handling condi-tions, liquid fuel could reach the carbon canister. If purge valves are reached by fuel this could affect functionality of the fuel EVAP system. EVAP system components faults could cause fuel vapors not treated properly. With not properly treated fuel vapor, particular maneuvers, as exam-ple engine over revving at idle, could imply contact be-tween fuel vapor and hot gasses. Especially if combined with a not approved aftermarket exhaust system this could lead to risk of fire.

**Field solution**

The instruction herein detailed describes three procedures:

- B, which requires upgrading EVAP system (=Robustness pack), the purge valve and fuel cap; powertrain and kombi software will need to be up-dated.
- C, which requires upgrading EVAP system (=Robustness pack), purge valve and fuel cap; power train only will need to be updated.
- D, which requires upgrading the EVAP system, purge valve and, at last, powertrain software.

**Spare parts.**

Order the following part number which are connected to the operation required:

- Operation B or C – (from VIN **CLA00091-HLA05374**).

P/N	Description	Q
470298019	Robustness pack	1
4T0133434	Purge valve kit	1
470298135	Plastic cap	1

- Operation D (from VIN **HLA05375-HLA05571**).

P/N	Description	Q
470298019	Robustness pack	1
4T0133434	purge valve kit	1

**Replaced parts management.**

Store properly and tagged the parts replaced with bar code form for their identification during Area Manager visits.

**Labour time**

- Operation B : **11,8** hours;

L73X-R.01.17	<b>To:</b> <b>Subject:</b> <b>Date:</b> <b>Pages</b>	<b>Official Lamborghini Service Network</b> <b>Update of fuel vapor circuit</b> <b>February 24, 2017</b> <b>58</b>	
--------------	---	---	---

- Operation C: **10,8** hours;
- Operation D: **10,3** hours.

**Substituted former Bulletins.**

L83X-A.11.14, L83X.A.14.14, L73X-A.01.16, L73X-A.02.16.

**Warranty Claim instructions**

To claim the reimbursement log into the warranty system management on the Lamborghini Portal and consults the manual “W.Claim “ available on the portal for the download .

Select the desired campaign and go on with the claim insertion, read carefully the windows message content and choose the option button corresponding to the operation performed .

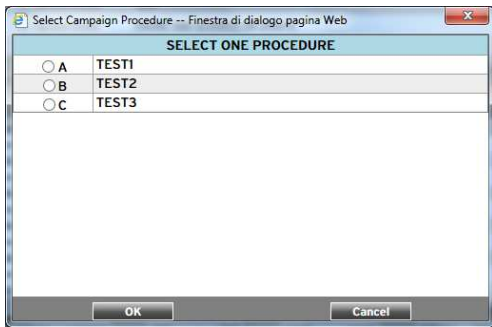

On the base of the chosen option the reimbursement will be:

- **OPTION B**, Robustness pack + purge valve + Fuel cap + powertrain software+ kombi manpower: *11,8 hours*  
spare parts: *470298019,4T0133434,470298135;*
- **OPTION C**: Robustness pack + purge valve + Fuel cap +powertrain software  
manpower: *10,8 hours;*  
spare parts: *470298019,4T0133434,470298135*
- **OPTION D**:  
- manpower: *10,3 hours;*  
- spare parts: *470298019,4T0133434,*



**ATTENTION!**

Attach all documents produced during the vehicle visit that show evidence of the work performed such as repair order, software protocols or acquisitions...etc.; the lack of one or more of those, may deny the reimbursement.

Remember to fill all data in the section “Service and Recall Campaign” in the Warranty booklet of the vehicle as shown below.

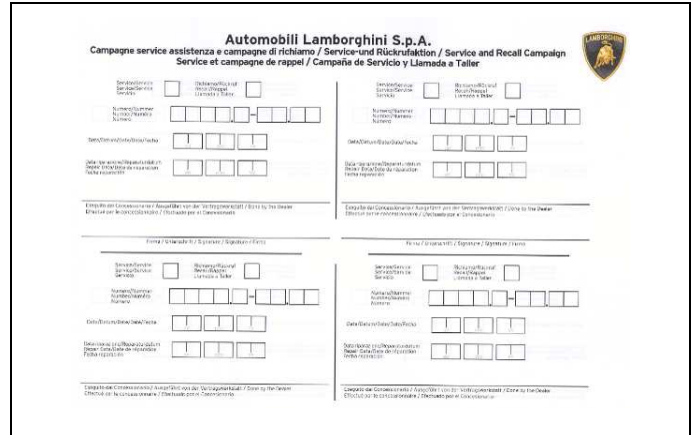

**Necessary tools/material.**

P/N	Description	Q
n/a	n/a-	n/a-

Rev.01	<p>The procedures and information published herein are strictly confidential and are intended exclusively for recognized professionals and persons who are authorized to receive said information. All copyrights are the property of Automobili Lamborghini S.p.A. pursuant to copyright law. The company reserves the right to make updates and modifications as needed. The reprinting, reproduction, distribution to unauthorized persons and/or to third parties, and the partial or complete translation of the material contained herein are prohibited without the express written consent of Automobili Lamborghini S.p.A. doc. nr. L/V6_M06 Rev.[02]</p>	2/58
--------	--	------



**Workshop instructions:**



**WARNING**



Procedure to be performed on a cold engine!



**WARNING**

The fuel used to run the engine is extremely inflammable, and in specific conditions can be explosive. Work in well-ventilated areas with the engine switched off. Do not smoke while refueling, and in the presence of fuel vapor, avoid naked flames, sparks and any other element which could ignite them or cause explosions. Dispose of fuel correctly following all applicable legislation.

**Preliminary operations.**

1. Position the vehicle on a car lift.
2. Removing the front cover.

Unscrew the 6 screws that secure the front cover then remove it.

Tighten the screws.

Tightening torque: **2.5 Nm.**

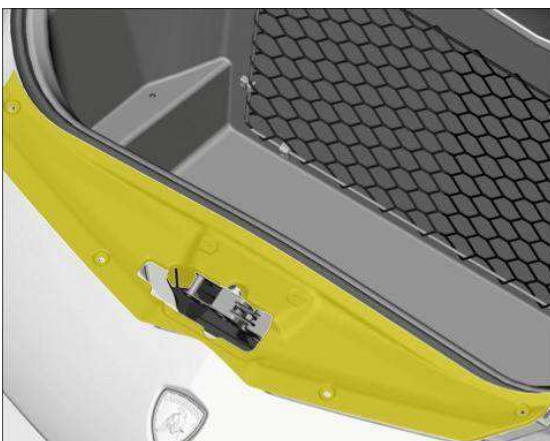

3. Disassembling the luggage compartment

Remove the 4 screws that secure the luggage compartment.

Tighten the screws.

Tightening torque: **8 Nm.**

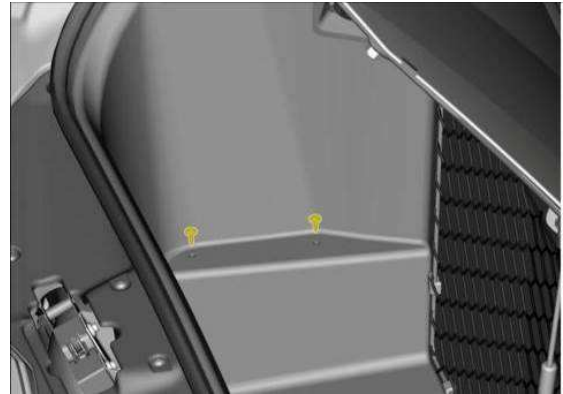

Lift the luggage compartment and disconnect the connector from the 12V socket.



Remove the luggage compartment to gain access to the battery.



**Note.**

Some versions of the Lamborghini Aventador are



equipped with luggage compartment with release handle inside.

Unscrew the 8 screws securing the ornament, then release the handle from the luggage compartment.

Tighten the screws.  
 Tightening torque: **2.5 Nm.**



Pull the handle out from the luggage compartment, then remove the component from the vehicle.

4. Disconnect the battery.



Note.

Open the door on the driver's side before disconnecting the battery.

- a. Aventador MY2012:

Disconnect the positive terminal on the battery.

Tighten the nut.  
 Tightening torque: **6 Nm.**

- b. Aventador MY2013 and following:

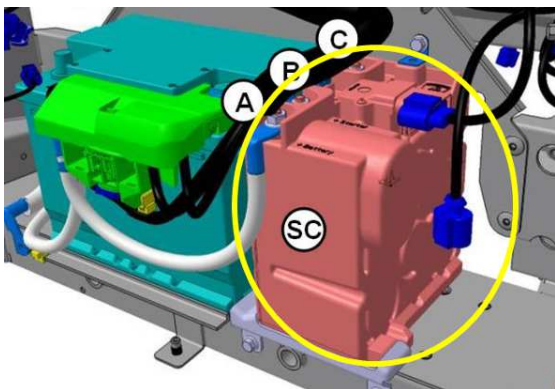

The Supercapacitor module provides the energy required to start the engine while the battery supplies the rest of the electric / electronic platform.

The device is highly electrically charged.



**WARNING!**

**Risk of electric shock:**

Before disconnecting the battery's positive terminal, proceed to discharge the supercapacitor using the appropriate tool (p/n 69195291).

Once the Supercapacitor discharge procedure has been completed be sure to verify that the voltage indicated on the tool's display is below 0.5V.

Disconnect the positive terminal on the battery

Tighten the nut.  
 Tightening torque: **6 Nm.**

5. Disassembling the engine hood.

Open the engine hood and then disconnect the supporting pistons from their two supporting brackets.

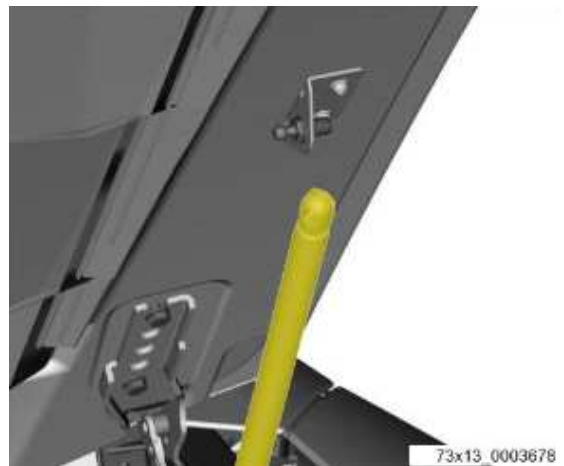

Unscrew the 4 screws fastening the hood hinges then remove the car's engine hood.

Tighten the screws.  
 Tightening torque: **21Nm.**

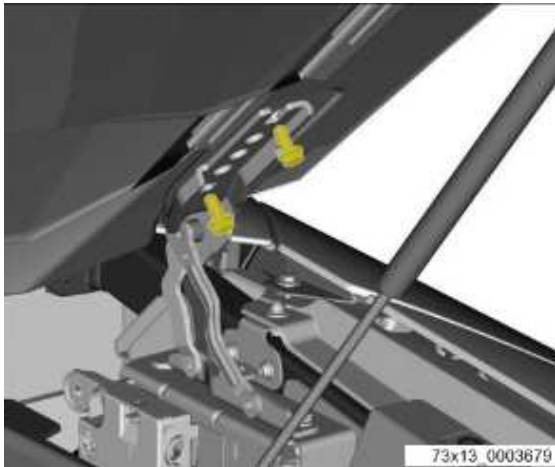

**Notes for reassembly:**

When reinstalling the engine hood make sure it is correctly aligned with the rest of the car's bodywork.

6. Disassembling the rear engine compartment cover.

Unscrew the 10 fastening screws and the 2 puffers then remove the engine compartment's rear panel.

Tighten the screws.

Tightening torque: **6 Nm**.

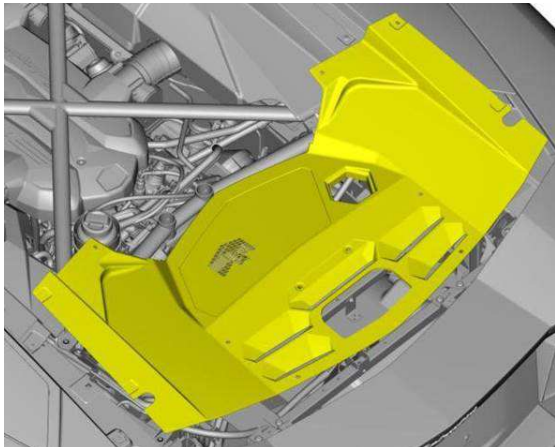

7. Disassembling the right front engine compartment cover.



**Note:**

This component is not present on the SV version.

Remove the 4 screws and remove the right front cover of the engine compartment

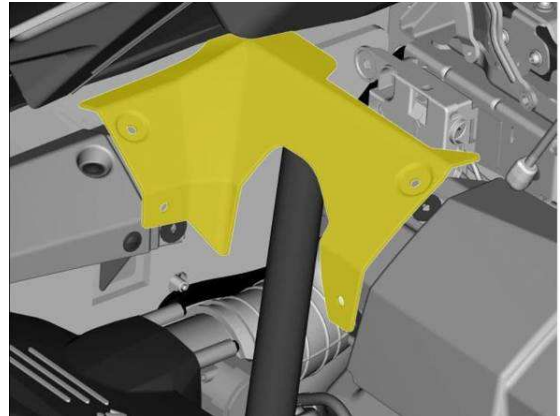

8. Disassembling the right engine compartment cover.



**Note:**

This component is not present on the SV version.

Remove the 4 screws and remove the right front cover of the engine compartment.

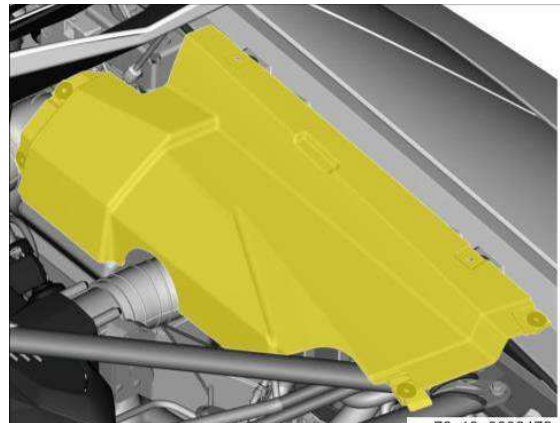

9. Disassembling the left engine compartment cover.



**Note:**

This component is not present on the SV version.

Remove the 5 screws and remove the left cover of the engine compartment.

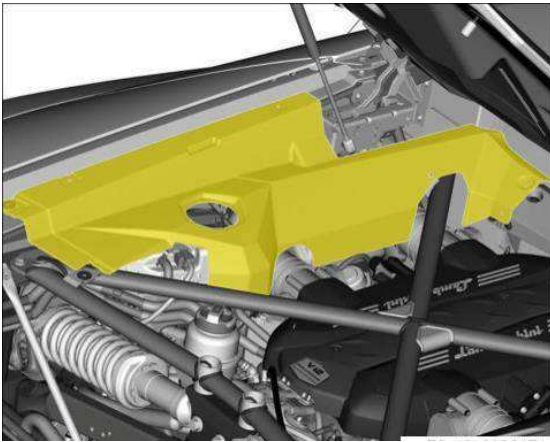

10. Disassembling the rear cross-shaped chassis.  
 Remove the screws that hold the rear cross-shaped chassis.

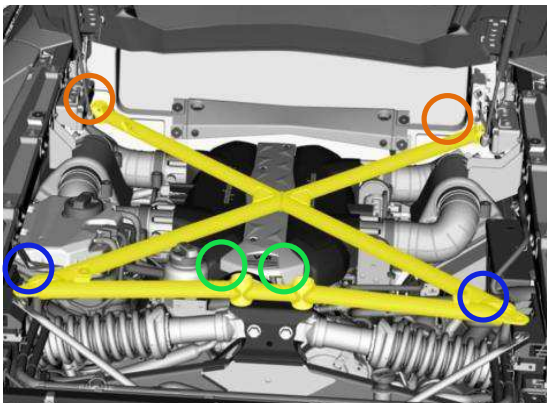

**Note**  
 The screws must be replaced every time they are removed.  
 Tighten the screws.  
 Screw tightening torque to rear chassis N0195306:  
**27Nm ± 10% (M8x25mm).**  
 Screw tightening torque to rear cross member N908 638 02:  
**27Nm ± 10% (M8x22mm).**  
 Screw tightening torque to monocoque N106 650 02:  
**40Nm ± 10% (M8x30mm).**

11. Remove the rear left wheel.  
 i. Wheels with mounting studs:



**Note**  
 In order not to damage the rim and the brake disk, use the specific tool (code 65395009).

Fixing the mounting studs.  
 Tightening torque: **160 Nm.**

ii. Wheels with single nut:



**Note**  
 In order not to damage the rim and the brake disk, use the specific tool (code 62553000293).

To remove the single nut use the specific tool (code 470012257)



**Notes for reassembly:**  
 In order to ensure correct tightening of the single nut, lubricate the thread on the hub (see image to side) with CASTROL OPTIMOL PASTE TA. Ensure that the other components are clean and free of grease.

Tighten the single nut.  
 Pre-tightening: **120 Nm.**

Tightening torque: **160 Nm.**



**Notes for reassembly:**  
 Once tightened verify the correct engagement of the locking system using the appropriate tool (code 62553000293).

12. Disassembling the rear left wheel arch.  
 Each wheel arch is made up of 2 parts, one front and one rear. Remove both elements.

Tighten the screws.  
 Tightening torque for M6 screws: **9Nm**  
 Tightening torque for other screws: **5 Nm**

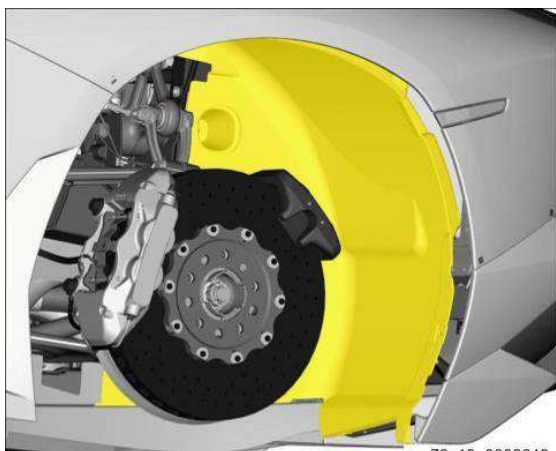

13. Disassembling the left front wheel.

i. Wheels with mounting studs:



**Note**

In order not to damage the rim and the brake disk, use the specific tool (code 65395009).

Fixing the mounting studs.

Tightening torque: **160 Nm.**

ii. Wheels with single nut:



**Note**

In order not to damage the rim and the brake disk, use the specific tool (code 62553000293).

To remove the single nut use the specific tool (code 470012257)



**Notes for reassembly:**

In order to ensure correct tightening of the single nut, lubricate the thread on the hub (see image to side) with CASTROL OPTIMOL PASTE TA. Ensure that the other components are clean and free of grease.

Tighten the single nut.

Pre-tightening: **120 Nm.**

Tightening torque: **160 Nm.**



Notes for reassembly:

Once tightened verify the correct engagement of the locking system using the appropriate tool (code 62553000293).

14. Disassembling the front left wheel arch.

Each wheel arch is made up of 2 parts, one front and one rear. Remove both elements.

Tighten the screws.

Tightening torque for M6 screws: **9Nm**

Tightening torque for other screws: **3 Nm**

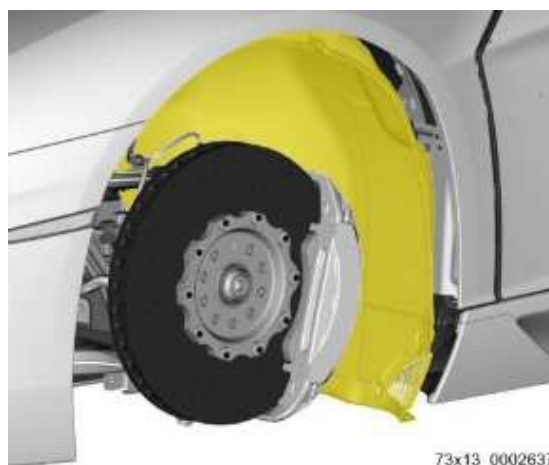

15. Disassembling the vehicle center floor panel.

Remove the 16 screws and remove the car's central floor panel.

Tighten the screws.

Tightening torque: **9 Nm.**

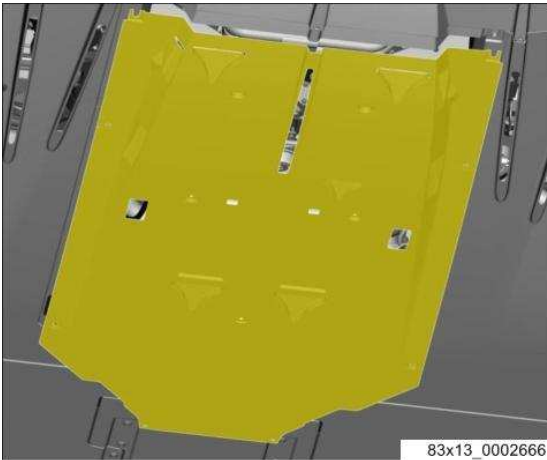

16. Disassembling the left rear floor panel.

Remove the 11 screws and remove the left rear floor panel.

Tighten the screws.  
Tightening torque: **9 Nm.**



**Note.**

The left rear floor panel will have to be modified before it is reinstalled in the car.

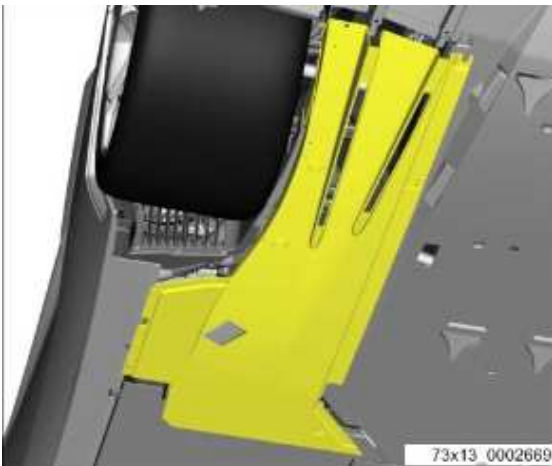

**Notes for reassembly:**

When reinstalling, check that the fuel vapor breather tube is positioned correctly. The breather tube must be placed at the center of the opening made on the floor panel, and must not be obstructed.



17. Removing the left side grille.

Unhook the grille from its special hooks then remove it.



18. Removing the left kick plate.

Unhook the kick plate from its special hooks then remove it.

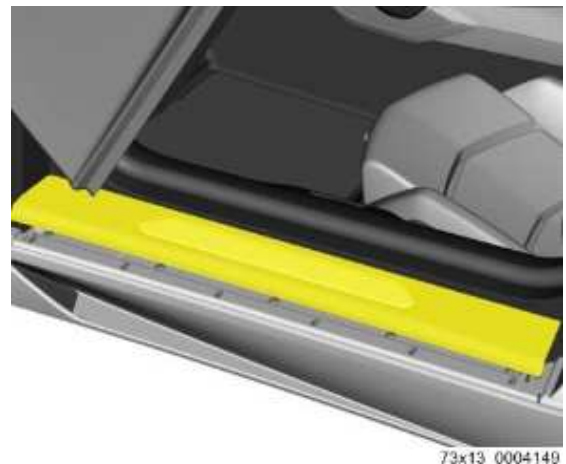





19. Removing the left side member.

Remove the 6 lower fixing screws.

Tighten the screws.

Tightening torque: **6 Nm**

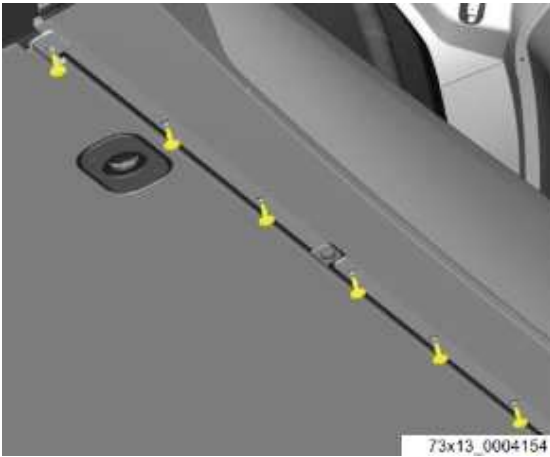

Unscrew the 5 upper fixing screws.

Tighten the screws.

Tightening torque: **6 Nm**

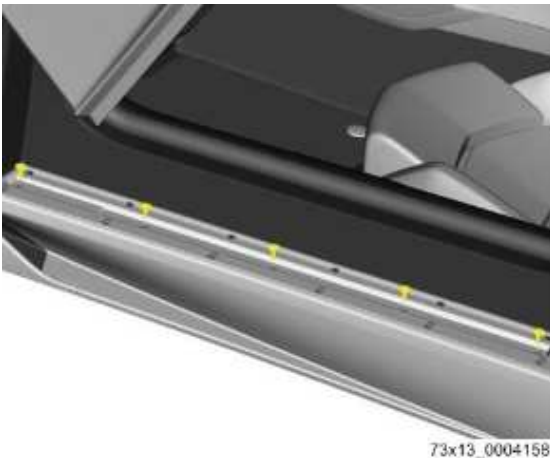

Unscrew the 2 front fixing screws.

Tighten the screws.

Tightening torque: **6 Nm**

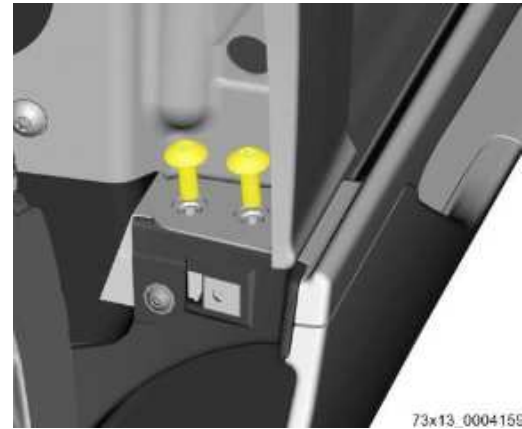

Unscrew the fixing screw close to the radiator.

Tighten the screws.

Tightening torque: **6 Nm**

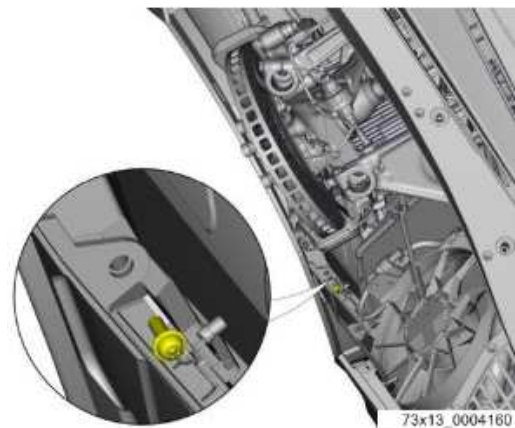

Unscrew the fixing screw located inside the air intake.

Tighten the screws.

Tightening torque: **6 Nm.**



L73X-  
R.01.17

To: Official Lamborghini Service Network  
Subject: Update of fuel vapor circuit  
Date: February 24, 2017  
Pages: 58



Unfasten the side member then remove it from the vehicle.



73x13\_0004164

#### 20. Removing the left lock cover.

Unscrew the fixing screw located by the lock then remove the cover.

Tighten the screws.

Tightening torque: **6 Nm**



73x13\_0004143

#### 21. Removing the left side beading.

Remove the 2 mounting screws located near the lock.

Tighten the screws.

Tightening torque: **6 Nm**



73x13\_0004191

Unscrew the fixing screw close to the radiator.

Tighten the screws.

Tightening torque: **6 Nm**



73x13\_0004192

Rev.01

The procedures and information published herein are strictly confidential and are intended exclusively for recognized professionals and persons who are authorized to receive said information. All copyrights are the property of Automobili Lamborghini S.p.A. pursuant to copyright law. The company reserves the right to make updates and modifications as needed. The reprinting, reproduction, distribution to unauthorized persons and/or to third parties, and the partial or complete translation of the material contained herein are prohibited without the express written consent of Automobili Lamborghini S.p.A. doc. nr. L/V6\_M06 Rev.[02]

10/58



Unscrew the mounting screw located close to the side member.

Tighten the screws.  
Tightening torque: **6 Nm**

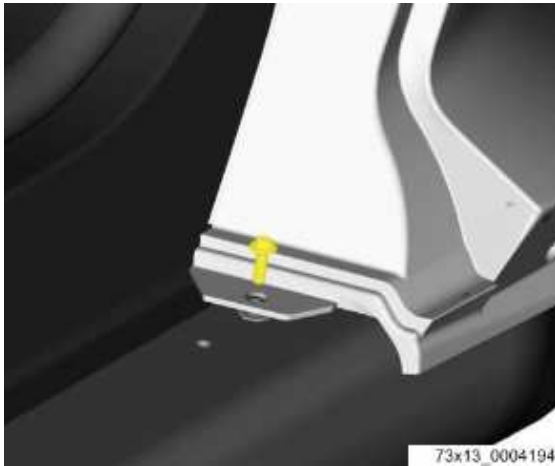

Unscrew the 2 mounting screws located in the lower part of the beading.

Tighten the screws .  
Tightening torque: **6 Nm**

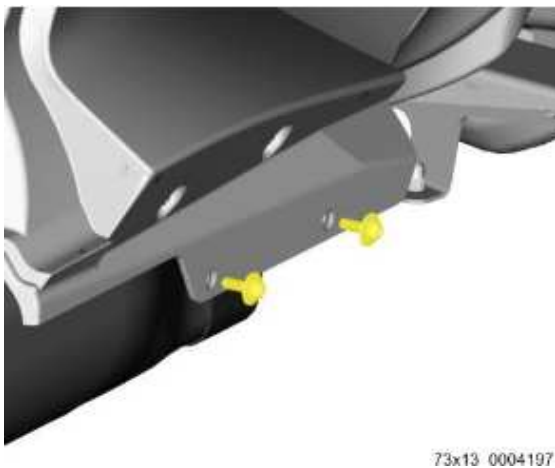

Remove the beading from the vehicle.



22. Removing the flexible air intake pipe.

Open the 2 clamps and then remove the flexible air intake pipe.



**Note.**

This procedure must be applied to the four flexible pipes that connect the air filter boxes to the air intake manifold.

Tighten the clamp.  
Tightening torque: **5 Nm**

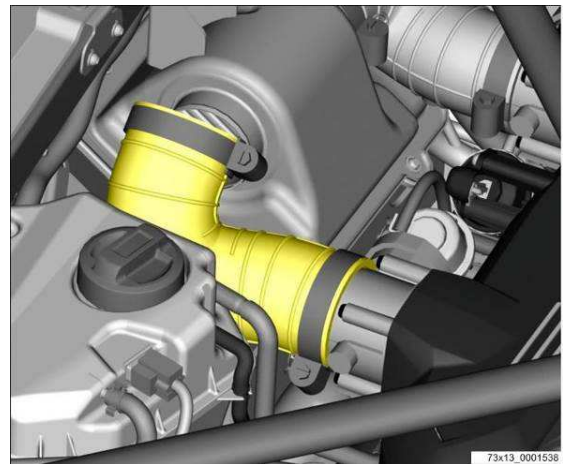

23. Removing the air filter housing cover.



**Note.**

This procedure must be applied to the two filter boxes.



Unscrew the 5 mounting screws then remove the top of the right air box.

Tighten the screws.  
Tightening torque M6: **10Nm**  
Tightening torque M5: **5 Nm**



24. Disassembling the filter cartridge.



**Note.**  
This procedure must be applied to the two filter boxes.  
Remove the air filter cartridge.

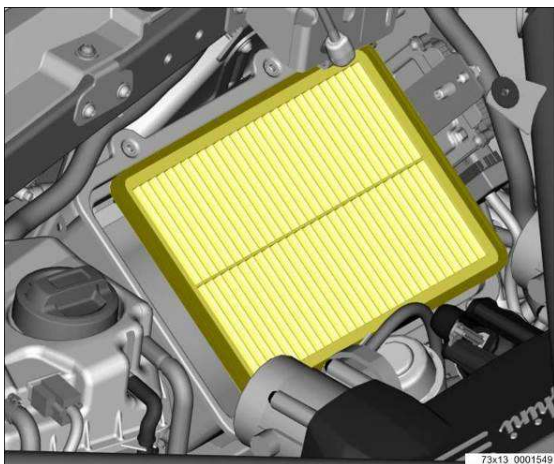

25. Disassembling the air filter housing.



**Note.**  
This procedure must be applied to the two filter boxes.

Disconnect the connectors to the ION control unit, unscrew the 2 mounting screws then remove the underside of the right air box along with the ION control unit.

Tighten the screws.  
Tightening torque: **20 Nm**

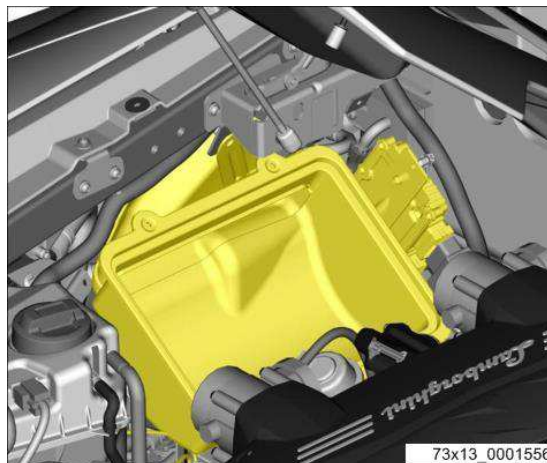

26. Removal of vacuum tank

Remove the 2 screws and then remove the car's vacuum tank.



**Note.**  
Take care not to damage the vacuum tank hoses during disassembly.

Tighten the screws.  
Tightening torque: **4,5 Nm**

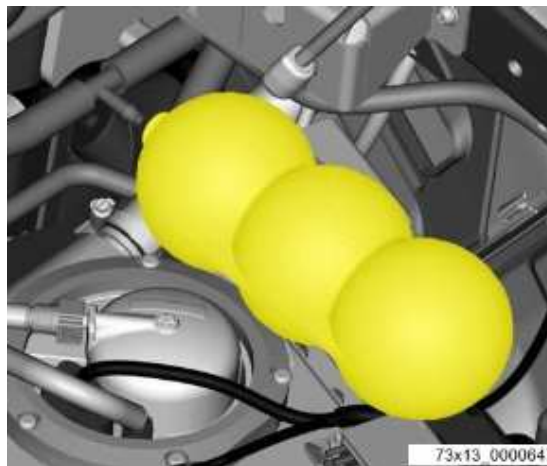

L73X- R.01.17	<b>To:</b> Official Lamborghini Service Network <b>Subject:</b> Update of fuel vapor circuit <b>Date:</b> February 24, 2017 <b>Pages:</b> 58	
------------------	---	---

27. Removing the gearbox control unit.

Unscrew the fastening nuts of the gearbox control unit, disconnect the electrical connections then remove the control unit along with the mounting bracket.

Tighten the screws.

Tightening torque: **9Nm**

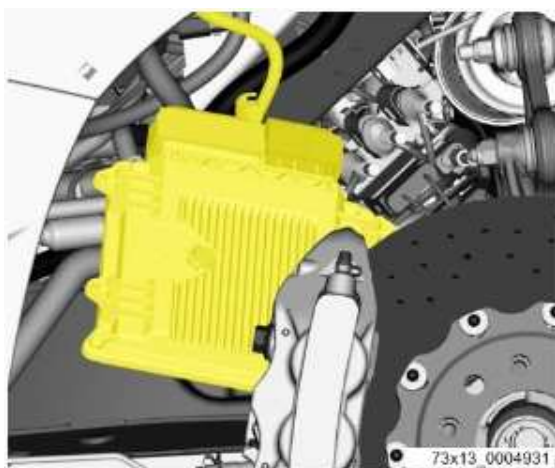

Rev.01	<p>The procedures and information published herein are strictly confidential and are intended exclusively for recognized professionals and persons who are authorized to receive said information. All copyrights are the property of Automobili Lamborghini S.p.A. pursuant to copyright law. The company reserves the right to make updates and modifications as needed. The reprinting, reproduction, distribution to unauthorized persons and/or to third parties, and the partial or complete translation of the material contained herein are prohibited without the express written consent of Automobili Lamborghini S.p.A. doc. nr. L/V6_M06 Rev.[02]</p>	13/58
--------	--	-------



**UPDATE OF FUEL VAPOR CIRCUIT**

The Lamborghini Aventador fuel vapor collection circuit has been subjected to a few technical updates. A diagram of the updated components of the fuel system to be installed on the vehicle is provided below.

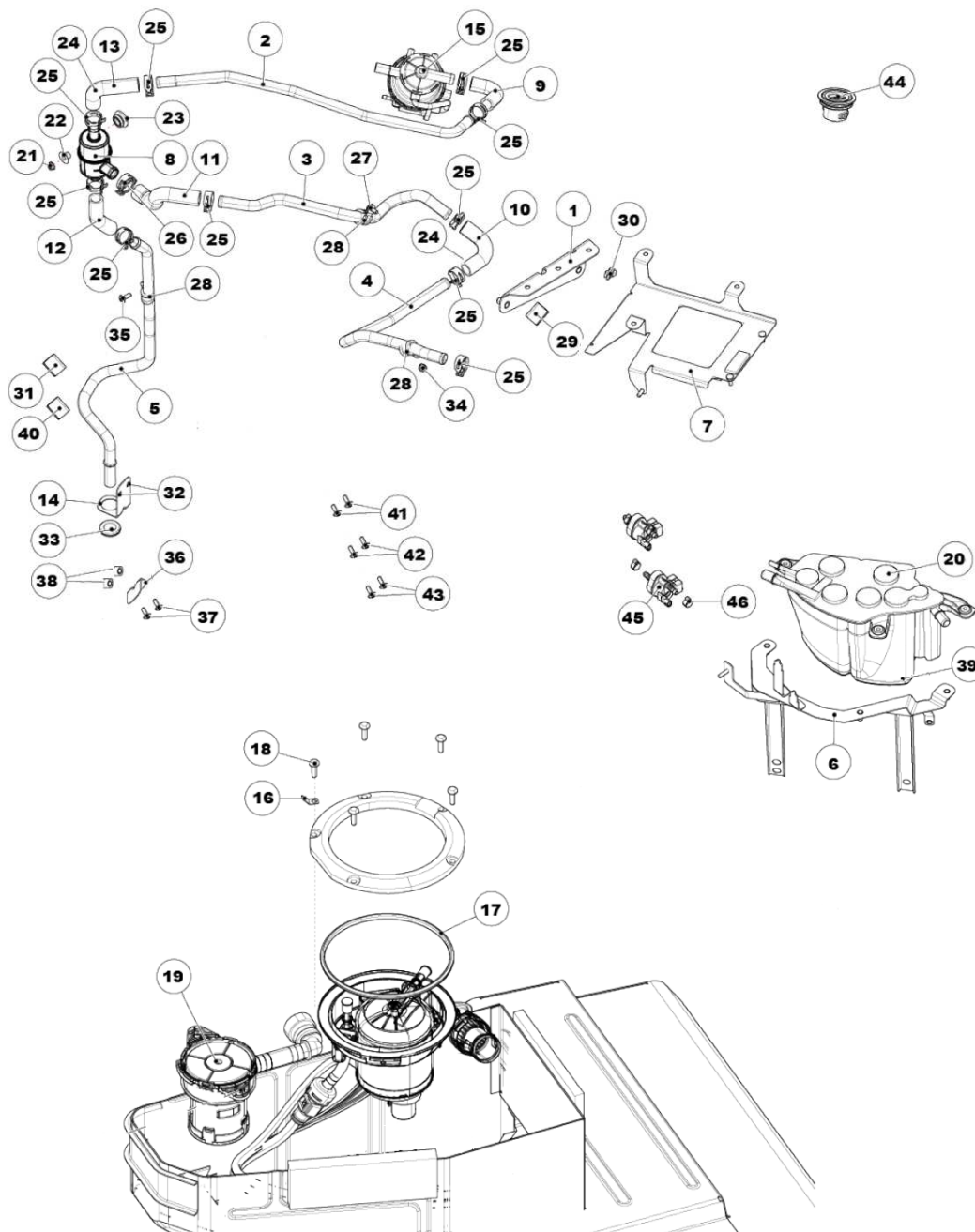

L73X-  
R.01.17

**To:** Official Lamborghini Service Network  
**Subject:** Update of fuel vapor circuit  
**Date:** February 24, 2017  
**Pages:** 58



IMAGE	PART NUMBER	DESCRIPTION	IMAGE	PART NUMBER	DESCRIPTION
1	470121703D	BRACKET	24	4T0127237	EDGE SHIELD
2	470131491C	BREATHER HOSE	25	4B0422379A	SPRING CLAMP
3	470201728	VENTILATION HOSE	26	N90687001	SPRING CLAMP
4	470201730	VENTILATION HOSE	27	N91096701	SCREW
5	470201411A	VENTILATION HOSE	28	N0206405	RETAINING CLAMP
6	470201898B	BRACKET ACC	29	4S0201152	EDGE PROTECTION
7	470927743C	ECU HOLDER	30	3D0971838M	CABLE TIE BASE
8	4S0201752	COMBINATION VALVE	31	03L121722	SPLINED SLEEVE
9	470201153B	HOSE	32	N90780903	SCREW WITH FLANGE
10	470201384	HOSE	33	400821190	GROMMET
11	470201352	HOSE	34	N01508213	FLANGE NUT
12	470201817	HOSE	35	N91071701	SCREW
13	470201908	HOSE	36	470825296	NOLDER
14	470201938	BRACKET	37	N90986803	SCREW
15	3C0906271A	LDP PUMP	38	N90170803	SPEED NUT
16	400201211	GROUNDING PLATE	39	470201283A	HEAT SHIELD
17	470201209	GASKET	40	410863939	ADHESIVE SHIELD
18	N10430104	SCREW	41	N90863802	SCREW
19	470201521D	VALVE FLVV	42	N0195306	SCREW
20	3D0201801F	ACTIVATED CARBON CANISTER	43	N10665002	SCREW
21	N01508210	FLANGE NUT	44	470298135	PLASTIC CAP
22	8Z0129734	SPACER	45	06H906517AB	PURGE VALVE
23	8Z0129669A	GROMMET	46	N10199201	HOSE CLAMP

Rev.01

The procedures and information published herein are strictly confidential and are intended exclusively for recognized professionals and persons who are authorized to receive said information. All copyrights are the property of Automobili Lamborghini S.p.A. pursuant to copyright law. The company reserves the right to make updates and modifications as needed. The reprinting, reproduction, distribution to unauthorized persons and/or to third parties, and the partial or complete translation of the material contained herein are prohibited without the express written consent of Automobili Lamborghini S.p.A. doc. nr. L/V6\_M06 Rev.[02]

15/58

L73X- R.01.17	<b>To:</b> Official Lamborghini Service Network <b>Subject:</b> Update of fuel vapor circuit <b>Date:</b> February 24, 2017 <b>Pages:</b> 58	
------------------	---	---

### IDENTIFICATION OF THE WORK AREA

To facilitate the performance of the operations in the vehicle the following instructions are subdivided as follows:

- A. Updating of the fuel vapor exhaust circuit, installation of the 3-way valve, replacement of the Activated Carbo Canister (ACC) filter and LDP diagnosis pump.
- B. FLVV valve update.
- C. Purge electro-valve update.
- D. Tank cap update.

The vehicle update can only be considered completed after having carried out all the operations reported under points: A – B – C – D – FINAL OPERATIONS

The updating operations must be performed by following the instructions provided in this bulletin with the utmost care.

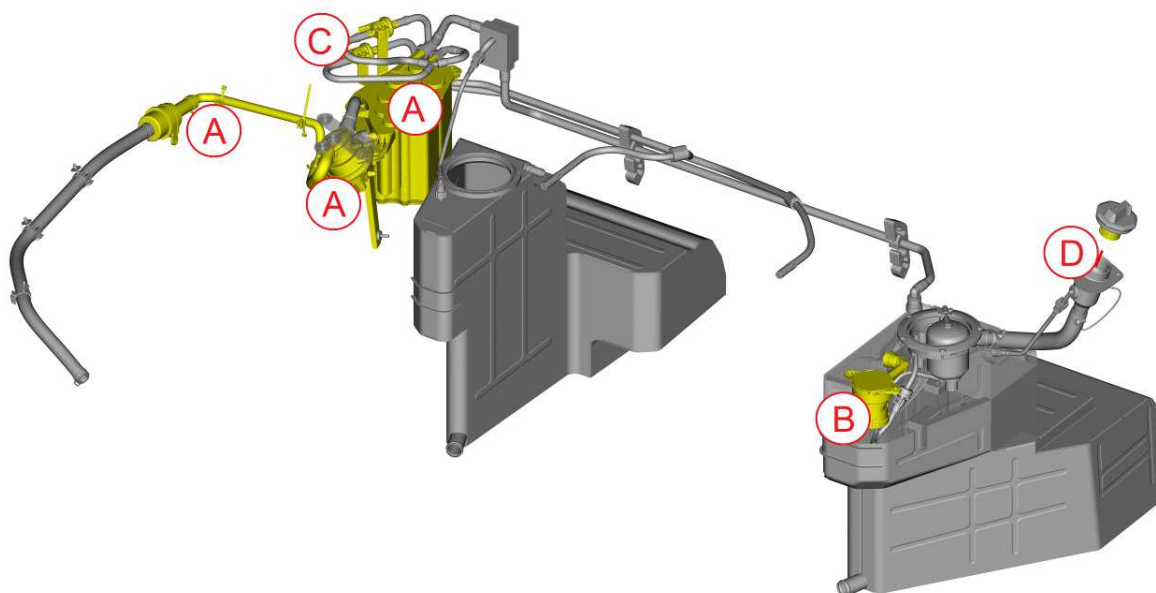

Rev.01	<p>The procedures and information published herein are strictly confidential and are intended exclusively for recognized professionals and persons who are authorized to receive said information. All copyrights are the property of Automobili Lamborghini S.p.A. pursuant to copyright law. The company reserves the right to make updates and modifications as needed. The reprinting, reproduction, distribution to unauthorized persons and/or to third parties, and the partial or complete translation of the material contained herein are prohibited without the express written consent of Automobili Lamborghini S.p.A. doc. nr. L/V6_M06 Rev.[02]</p>	16/58
--------	--	-------





**Updating of the fuel vapor exhaust circuit, installation of the 3-way valve, replacement of the Activated Carbon Canister (ACC) filter and LDP diagnosis pump.**



**Note.**  
Clean the work area and the various components before carrying out the disassembly operations. Make sure no dirt or other material can contaminate the fuel vapor circuit.

28. Removing the left side conveyor.

Unscrew the 4 screws fastening the left side conveyor then remove the component from the vehicle.

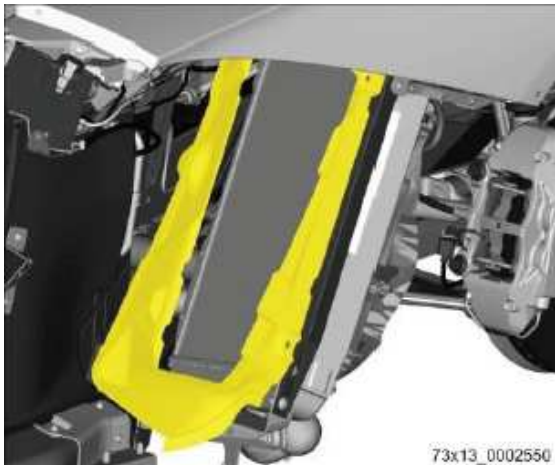

29. Removing the E-gear control unit retaining bracket.

Release the elements fixed to the E-Gear control unit retaining bracket, unscrew the three fixing nuts then remove the component from the vehicle.



**Note.**  
After removal this component must not be reinstalled on the vehicle.

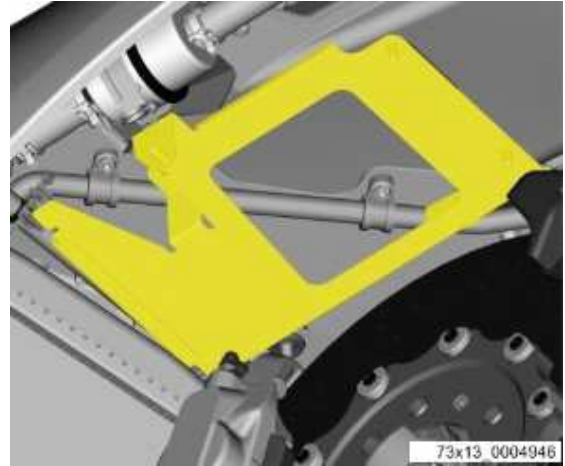

30. Disassembly of the fuel vapor filter.

Open the 2 band clamps, release the filter from the hoses then remove the component from the vehicle.



**Note.**  
After removal this component must not be reinstalled on the vehicle.

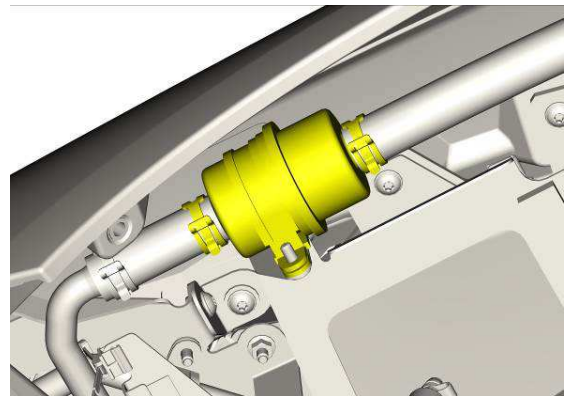

31. Removing the filter connector hose.

Open the spring clamp, release the connector hose then remove the component from the vehicle.



**Note.**  
After removal this component must not be reinstalled on the vehicle.

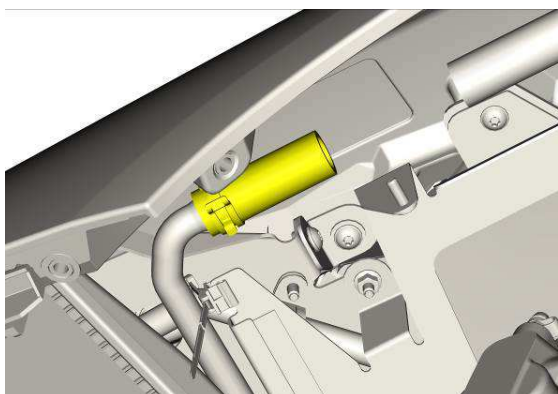

### 32. Disassembly of fuel vapor exhaust hoses.

Open the spring clamp, release the fuel vapor exhaust hoses, then remove the component from the vehicle.



**Note.**

After removal this component must not be reinstalled on the vehicle.

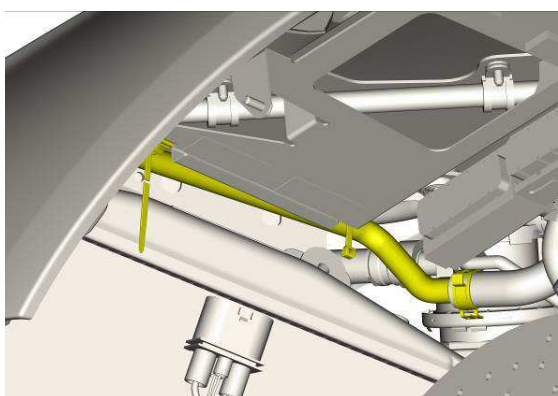

### 33. Removing the LDP pump connector hose.

Open the spring clamp, release the LDP pump connector hose then remove the component from the vehicle.



**Note.**

After removal this component must not be reinstalled on the vehicle.

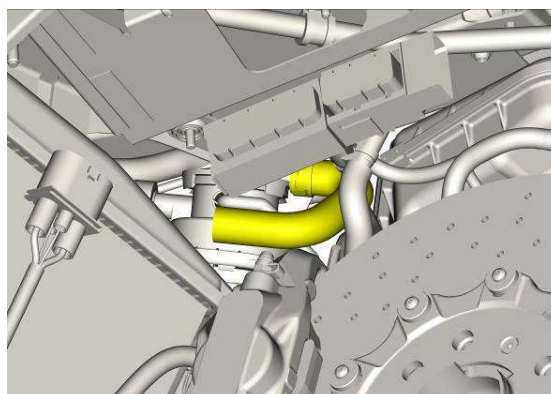

### 34. ACC filter removal.

Unscrew the 3 fixing screws, disconnect the 3 hoses then remove the vehicle's AKF filter.



**Note.**

Take care not to damage the hoses or quick couplings during disassembly.



**Note.**

The ACC filter must be replaced after disassembly.

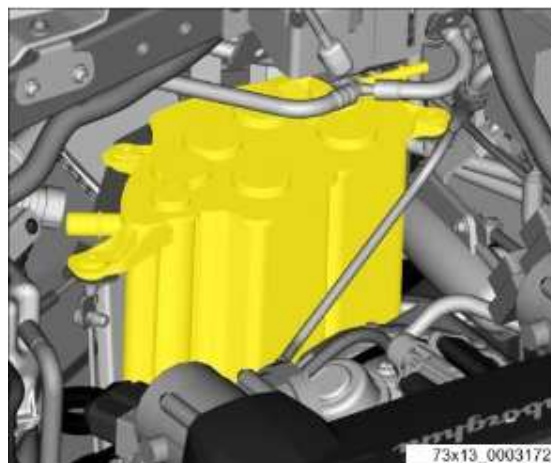

### 35. Removing the ACC filter connector hose.

Disconnect the connector hoses and remove the component from the vehicle.



**Note.**



Take care not to damage the hoses or quick couplings during disassembly.

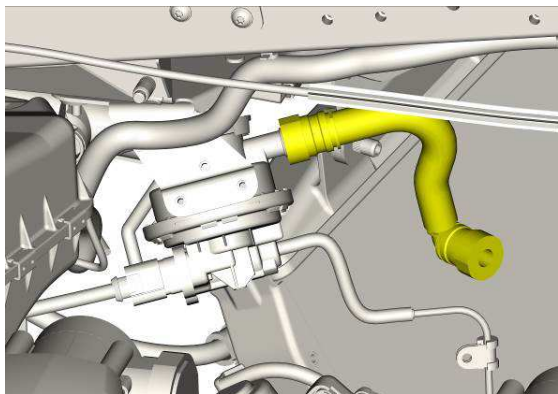

### 36. Disassembly of the LDP diagnosis pump

Remove the connector and the pneumatic hoses, unscrew the 3 screws then remove the component from the vehicle.



**Note.**

The LDP diagnosis pump must be replaced after disassembly.

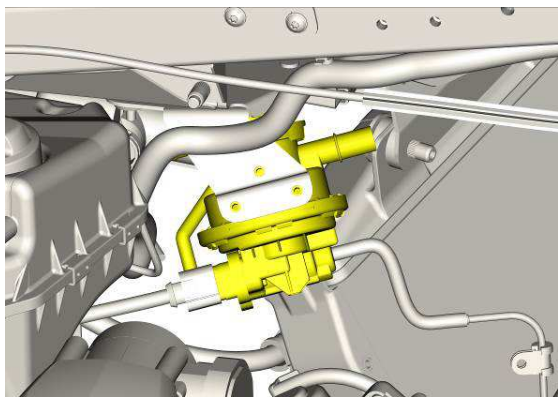

### 37. Disassembly of AKF filter bracket.

Release the fuel vapor hoses from the bracket, unscrew the 3 fixing screws then remove the bracket from the vehicle.



**Note.**

After removal this component must not be reinstalled on the vehicle.

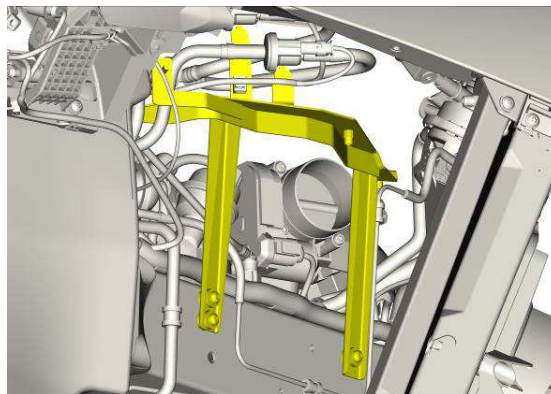

### 38. Disassembly of the left radiator's upper bracket.

Unscrew the screws and fastening nuts of the left radiator's upper bracket then remove the component from the vehicle.



**Note.**

After removal this component must not be reinstalled on the vehicle.

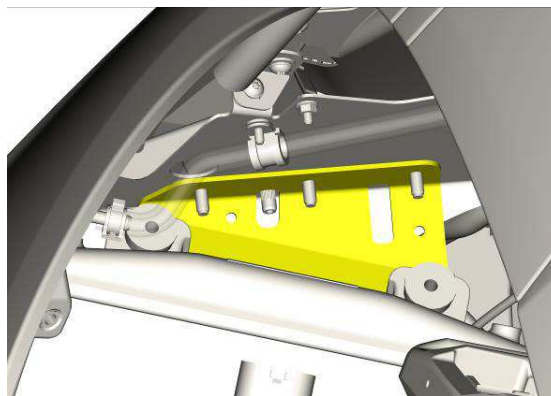

### 39. New left radiator upper bracket installation.

Install a new upper support bracket for the left radiator (p.n. 470121703D) then secure the component in the vehicle.

Tightening:

Tightening torque for M8 nuts: **20 Nm**

Tightening torque for M8 screws: **20Nm.**

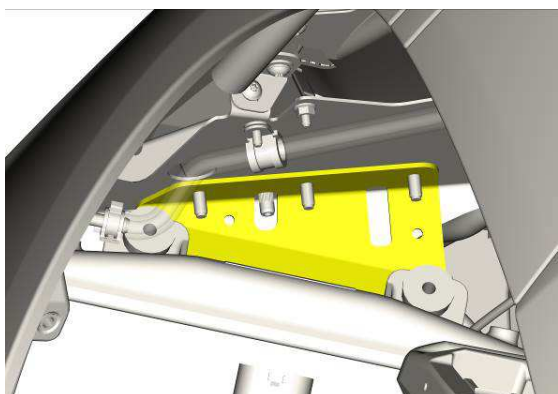

40. Disassembly of the left radiator lower bracket.

Unscrew the seven fixing screws of the left radiator's lower bracket then remove the component from the vehicle.



**Note.**

The left radiator lower support bracket must be modified before being reinstalled in the vehicle.

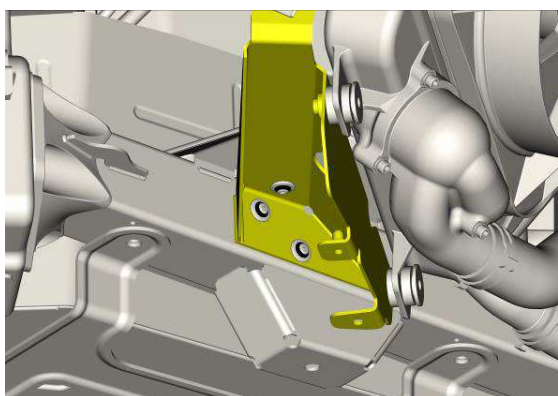

41. Modification of the left radiator lower bracket.

To facilitate the modification of the left radiator lower bracket, a PDF file has been provided as an attachment to this bulletin, which once printed and cut out can be used as a stencil for the drilling of the two Ø 6.5mm holes. Print the PDF file on A4 paper.

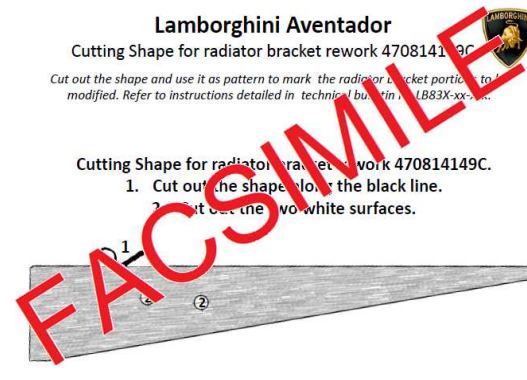

Lay the stencil over the bracket lining up the lower edge (red arrows in the figure) then mark the position of the two holes.

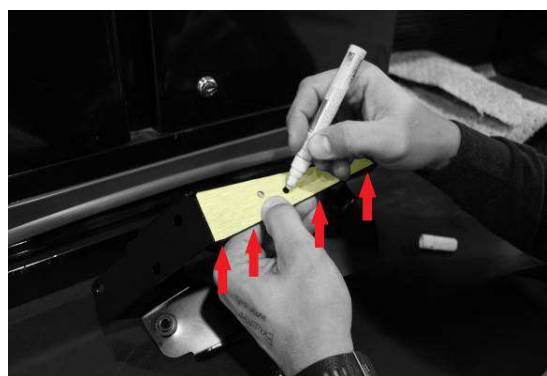

Drill the holes in the bracket with a Ø6.5mm drill bit on the marks made with a marker (yellow arrows in the figure).

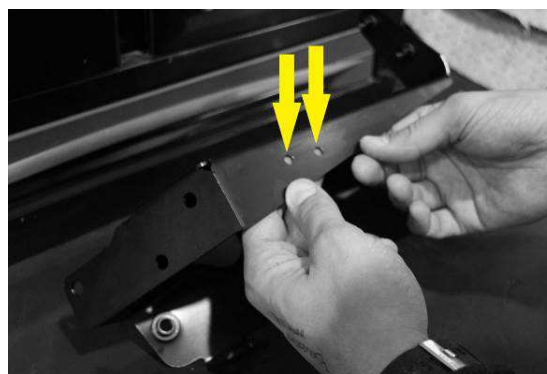

42. Installation of the left radiator lower bracket.

Install the modified left radiator bracket then secure the component in the vehicle.



Tightening.

Tightening torque for M8 screws: **25 Nm.**

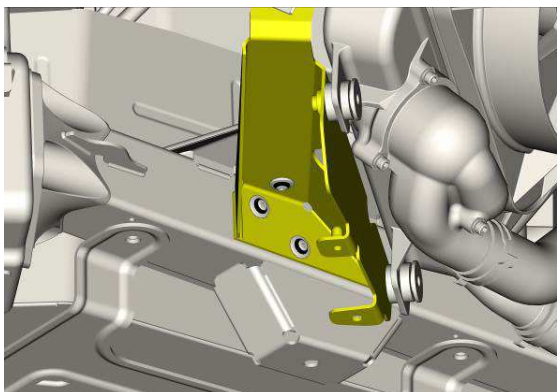

#### 43. Assembly of the fuel vapor hose bracket.

Assemble the fuel vapor hose bracket (p.n. 470231938) as shown in the figure using the grommet (p.n. 400821190).

Mount the assembled component to the previously modified bracket using two M6 screws (p.n. N90780903).

Tightening:

Screw tightening torque: **9 Nm.**

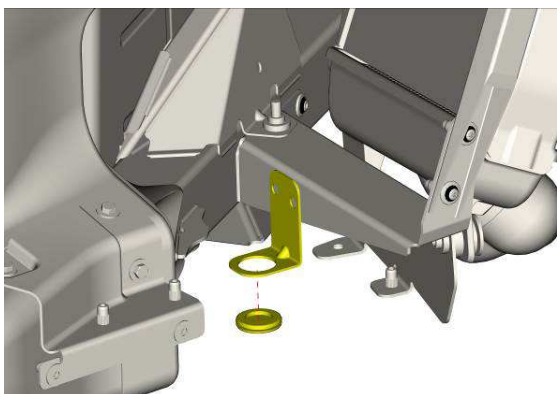

#### 44. Installation of new ACC filter bracket.

Install the new bracket for the ACC filter (p.n. 470201898B) then secure the component in the vehicle.

Recover the rubber bushes from the old support removed under point 37 of this procedure for fastening.

Tightening:

Screw tightening torque: **10 Nm.**

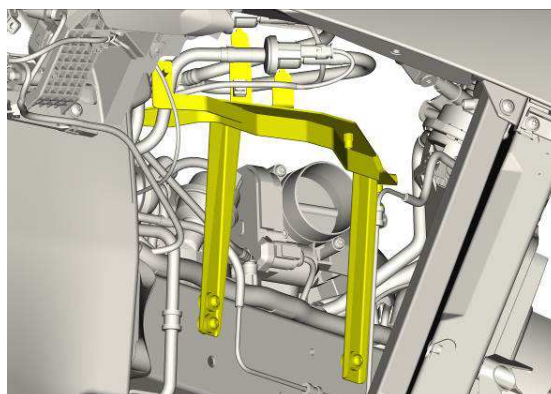

Fix the fuel vapor hoses to the specific supports found on the ACC filter bracket.



#### 45. Installation of a new LDP diagnosis pump.

Install the new LDP diagnosis pump (p.n. 3C0906271A) then secure the component in the vehicle.

Connect the connector and the pneumatic hoses.

Tightening:

Screw tightening torque: **6 Nm.**

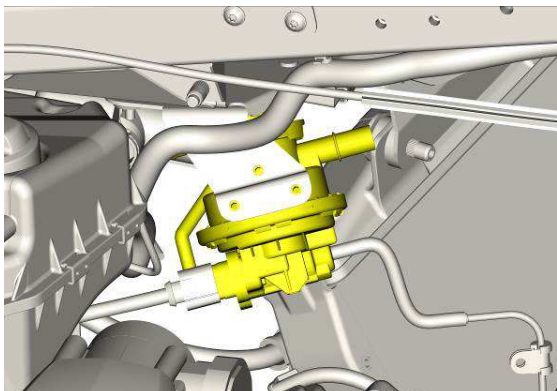

#### 46. Assembly of the ACC filter connector hose.

Install the ACC filter connector hose in the vehicle and connect it to the LDP diagnosis pump.



#### Note.

Take care not to damage the hoses or quick couplings during assembly.



#### Note.

Verify the correct engagement and fixing of the quick couplings of the fuel vapor circuit hoses.

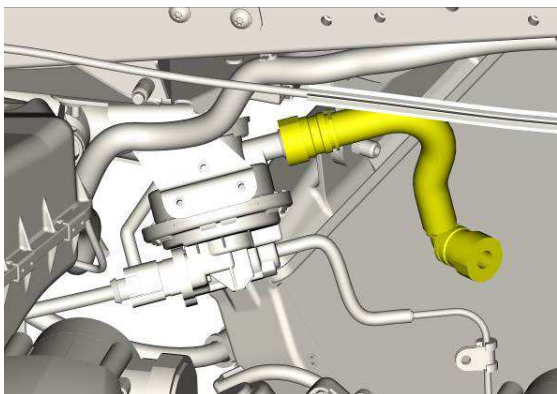

#### 47. Installation of new ACC filter thermal protection.

Apply the thermal protection (p.n. 470201283A) to the new ACC filter (p.n. 3D0201801F) as shown in the figure.

The adhesive protection must be applied to the lower part of the filter.



73x13\_0003173

#### 48. Installation of a new ACC filter.

Install the new ACC filter (p.n. 3D0201801F) complete with thermal protection then secure the component in the vehicle.

Tightening:

Screw tightening torque: **10 Nm.**

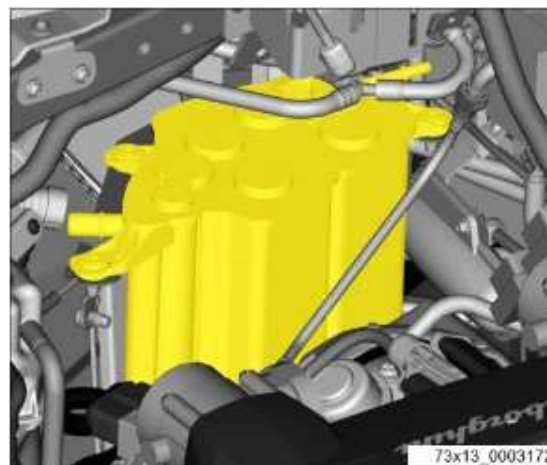

73x13\_0003172



#### Note.

Take care not to damage the hoses or quick couplings during assembly.



#### Note.

Verify the correct engagement and fixing of the quick couplings of the fuel vapor circuit hoses.



Connect the LDP diagnosis pump connector hose to the ACC filter.

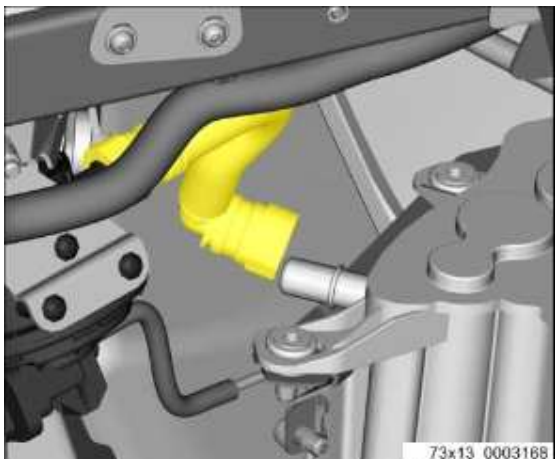

Connect the fuel vapor hose to the ACC filter as shown in the figure.

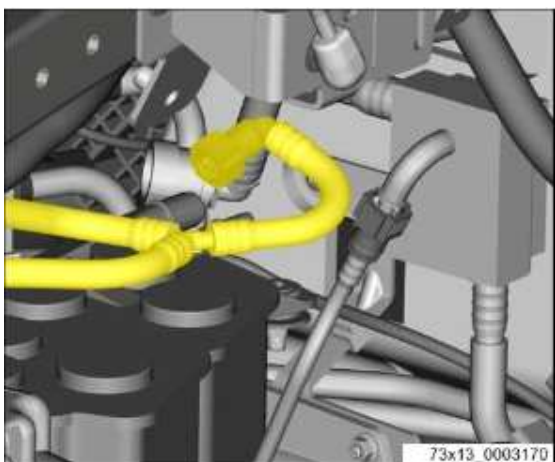

Connect the fuel vapor hose to the ACC filter as shown in the figure.

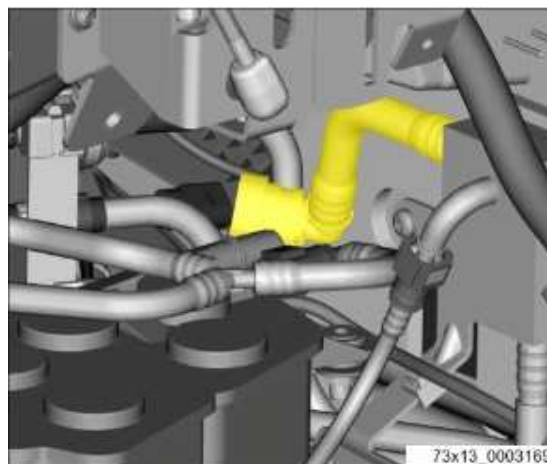

#### 49. Installation of the new 3 - way combination valve.

Assemble the new 3 - way valve (p.n. 4S0201752) with the grommet (p.n. 8Z0129669A) and the bushing (p.n. 8Z0129734) as shown in the figure.

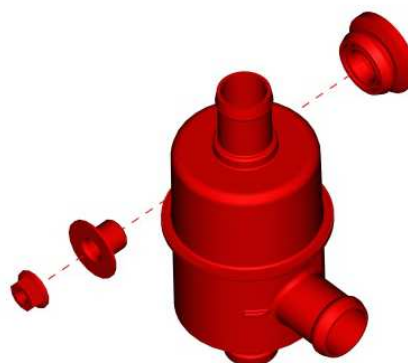

Install the new, previously assembled, 3 - way combination valve and fix it to the ACC filter bracket as shown in the figure using the flange nut (p.n. N01508210).

Tightening:  
Flange nut tightening torque: **9 Nm**.

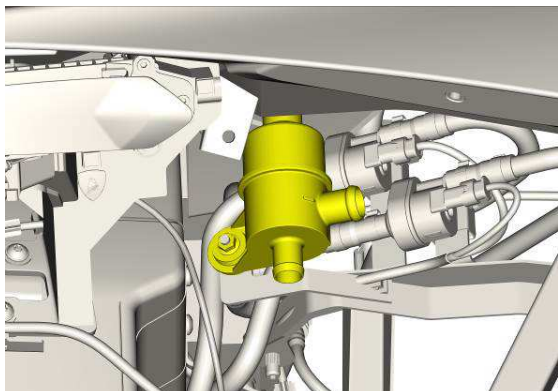

50. Work bench assembly of the new fuel vapor exhaust hose.

On the work bench assemble the new fuel vapor exhaust hose (p.n. 470201411A) with the new rubber connector hose (p.n. 470201817), fix the components with a spring clamp (p.n. 4B0422379A).



**Note.**

Align the hoses as shown in the figure.



**Note.**

Position the spring clamps on the rubber hose between the white lines as shown in the figure.



51. Work bench assembly of the new 3 - way combination valve breather hose.

Assemble on a work bench the new 3 - way combination valve breather hose (p.n. 470131491C) with the new rubber connector hose (p.n. 470201908), fix the components with a spring clamp (p.n. 4B0422379A).



**Note.**

Align the hoses as shown in the figure.



**Note.**

Position the spring clamps on the rubber hose between the white lines as shown in the figure.







Insert the edge shield (4T0127237) on the rubber connector hose (p.n. 470201908).



Assemble on a work bench the new 3 - way combination valve breather hose (p.n. 470131491C) with the new rubber connector hose (p.n. 470201153B), fix the components with a spring clamp (p.n. 4B0422379A).



**Note.**

Align the hoses as shown in the figure.



**Note.**

Position the spring clamps on the rubber hose between the white lines as shown in the figure.



52. Work bench assembly of the new air intake ventilation hose.

Assemble on a work bench the new air intake ventilation hose (p.n. 470201728) with the new rubber connector hose (p.n. 470201352), fix the components with a spring clamp (p.n. 4B0422379A).



**Note.**

Align the hoses as shown in the figure.



**Note.**

Position the spring clamps on the rubber hose as shown in the figure.



Assemble on a work bench the new air intake ventilation hose (p.n. 470201728) with the new rubber connector hose (p.n. 470201384), fix the components with a spring clamp (p.n. 4B0422379A).



**Note.**

Align the hoses as shown in the figure.



**Note.**

Position the spring clamps on the rubber hose between the white lines as shown in the figure.



Insert the edge shield (p.n. 470201384) on the rubber connector hose (4T0127237).



Assemble on a work bench the new air intake ventilation hose (p.n. 470201730) with the new rubber connector hose (p.n. 470201384), fix the components with a spring clamp (p.n. 4B0422379A).



**Note.**  
Align the hoses as shown in the figure.



**Note.**  
Position the spring clamps on the rubber hose as shown in the figure.



53. Assembly of the new fuel vapor exhaust hose.

Install the new fuel vapor exhaust hose assembled under point 50 of this procedure.

Using a pair of scissors, cut an aperture on the grommet as shown in the figure.

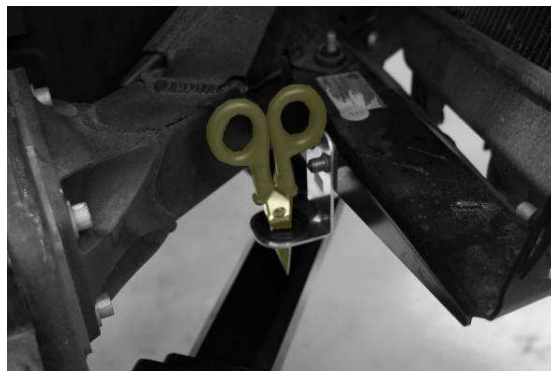

**Note.**  
Position the hoses in such a way as to avoid contact and interference with other vehicle components.

Insert the hose into the support connected to the lower radiator bracket.

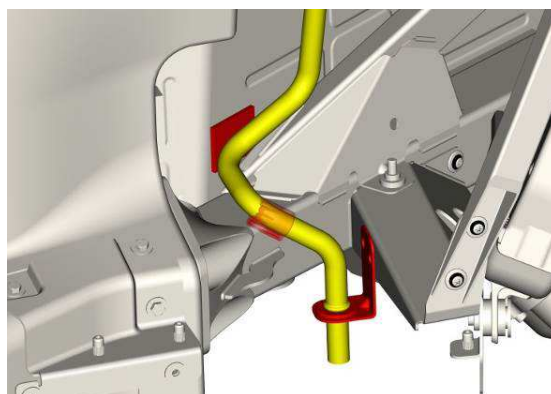

Connect the hose to the lower connector of the 3 - way combination valve as shown in the figure, fix the components using a spring clamp (p.n. 4B0422379A).





Fix the hose to the chassis by means of the steel-rubber retaining clamp (p.n. N0206405).

Tightening.

Screw tightening torque: **9 Nm**.

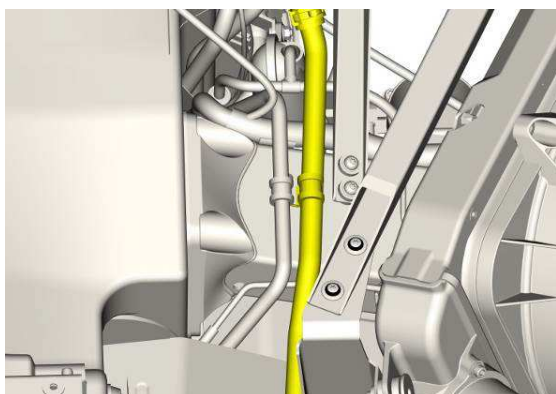

54. Assembly of the new 3 - way combination valve breather hose.

Install a new hose connecting the 3 - way combination valve assembled under point 51 of this procedure.



**Note.**

Position the hoses in such a way as to avoid contact and interference with other vehicle components.

Position the hose in the vehicle as shown in the figure.

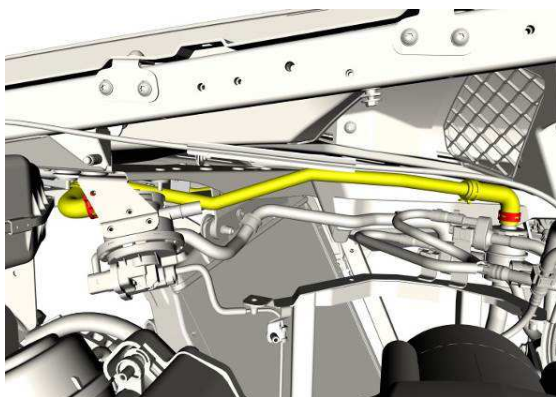

Connect the hose to the upper connector of the 3 - way combination valve as shown in the figure, fix the components using a spring clamp (p.n. 4B0422379A).

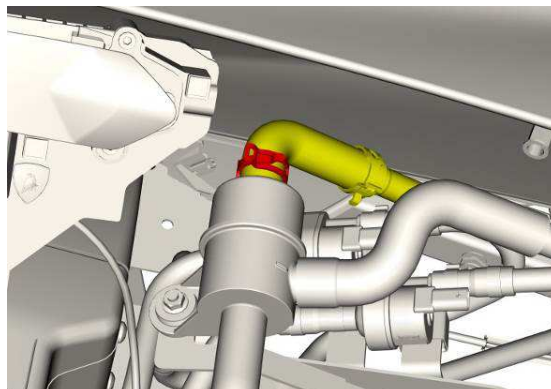

Connect the connector hose of the LDP diagnosis pump as shown in the figure, fix the components using a spring clamp (p.n. 4B0422379A).

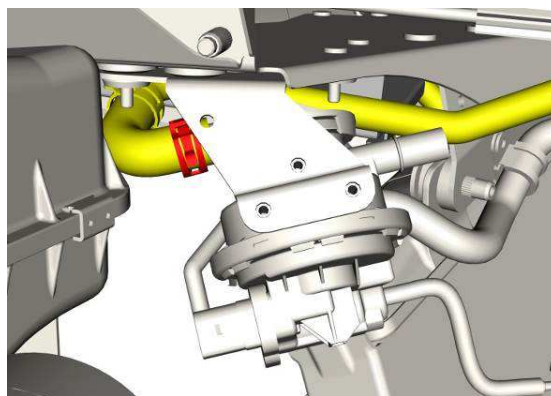

55. Installation of a new air intake ventilation hose.

Install the new air intake hose assembled under point 52 of this procedure.



**Note.**

Position the hoses in such a way as to avoid contact and interference with other vehicle components.

Connect the hose to the side connector of the 3 - way combination valve as shown in the figure, fix the components using a spring clamp (p.n. 4B0422379A).

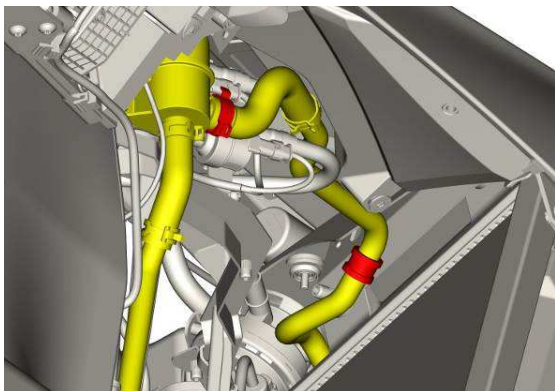

Position the hose in the vehicle as shown in the figure below.

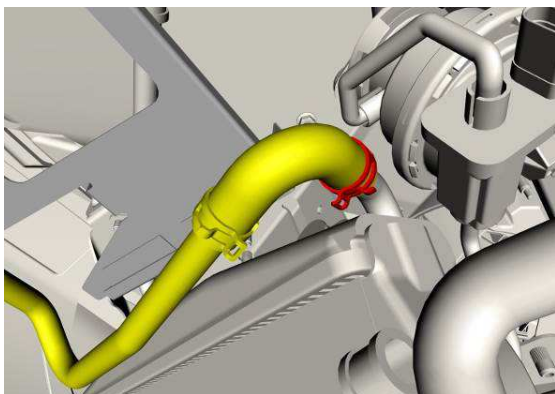

Position the hose in the vehicle as shown in the figure below.

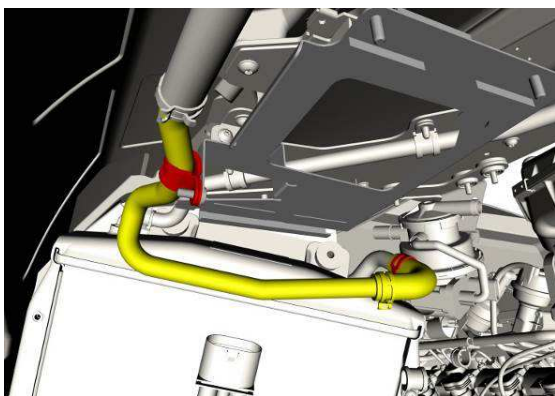

Fix the hose to the pipe located in the vehicle, previously connected to the fuel vapor filter, using a spring clamp (p.n. 4B0422379A).



**Note.**

Check that there are no interferences between the air intake ventilation hose and the hoses connected to the LDP diagnosis pump.

Position the hoses as shown in the figure:

- Green: the hose connected with the 3 - way combination valve.
- Blue: the air intake ventilation hose.
- Red: the pneumatic hose connected to the LDP diagnosis pump.

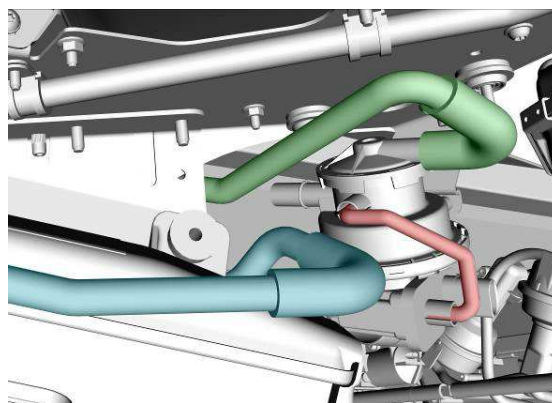

**56. Installation of the left side conveyor.**

Install the left side conveyor into the vehicle and secure it with the 4 screws.

**Tightening.**

Screw tightening torque: **9 Nm.**

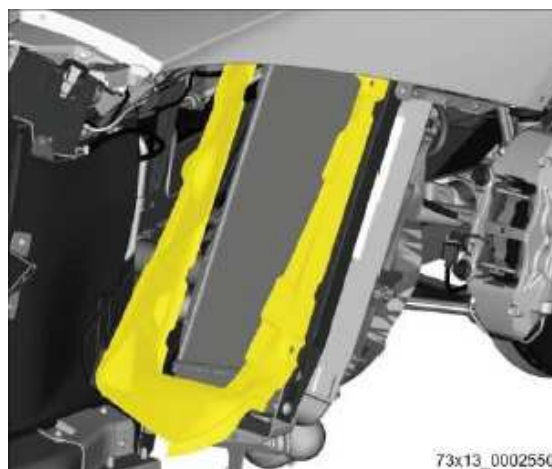

73x13\_0002550



57. Assembly of the fuel vapor exhaust hose shields.

Identify the area indicated by the red arrow.

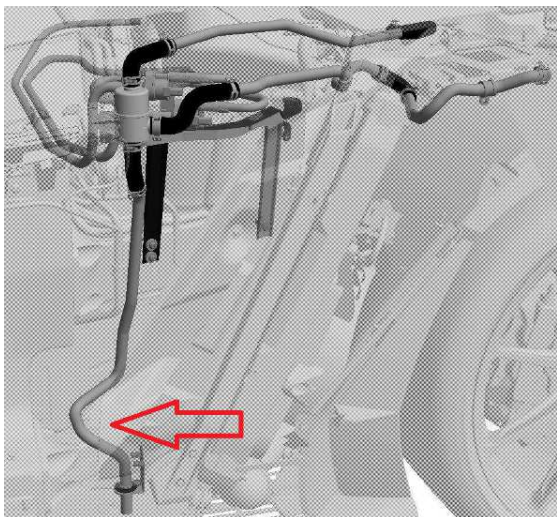

Clean the tank and glue the protection (p.n. 410863939) on as shown in the figure. Install the splined sleeve (p.n. 03L121722 ) on the hose at the conveyor.



58. Fix the 3 - way combination valve pipe.

Identify the area indicated by the red arrow.

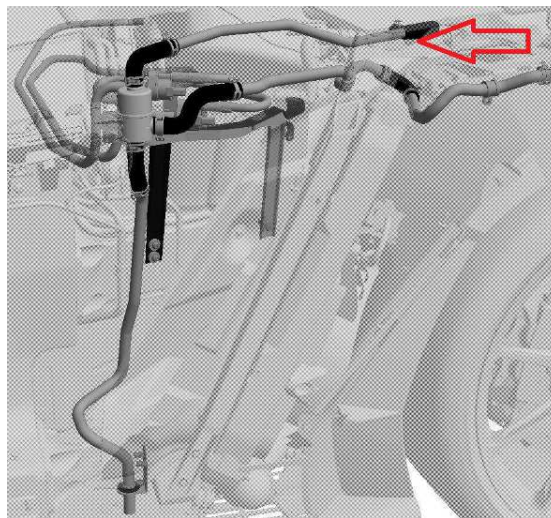

Fix the hose installed under point 54 of this procedure to the upper radiator bracket using the retaining clamp (p.n. 3D0971838M) as shown in the figure.

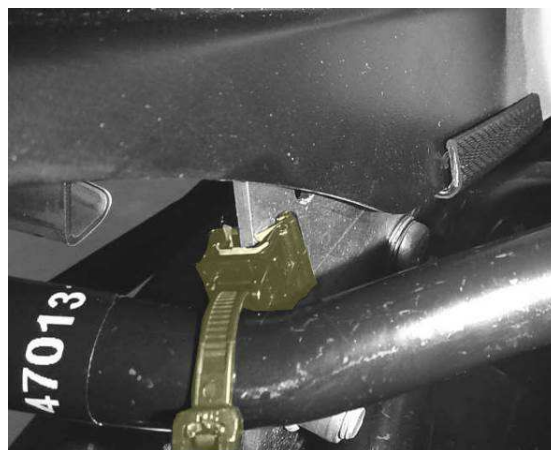

59. Fix the air intake pipe.

Identify the area indicated by the red arrow.

L73X-  
R.01.17

To: Official After Sales Network  
Subject: Evap system update  
Date: February 23, 2017  
Pages: 58

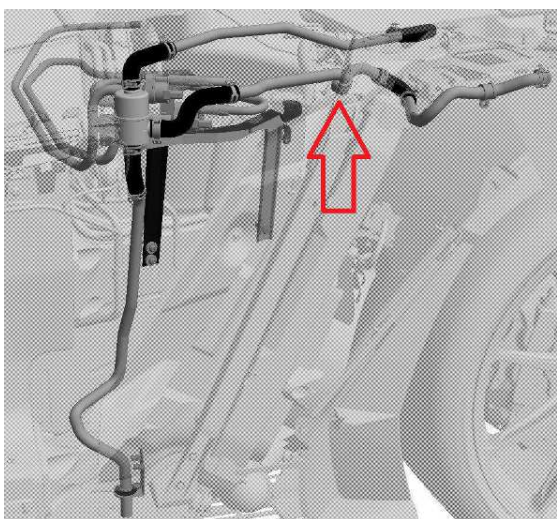

Fix the hose installed under point 55 of this procedure to the upper radiator bracket using the retaining clamp (p.n. N0206405) as shown in the figure using the screw (p.n. N91097601).

**Tightening.**

Screw tightening torque: **9 Nm.**

Position the rubber shield (p.n. 4S0201152) at the bend of the hose as shown in the figure.



**60. Modifying the left rear floor panel.**

To facilitate the modification of the left rear floor panel, a PDF file has been provided as an attachment to this bulletin, which once printed and cut out can be used as a stencil for the floor panel modification. Print the PDF out on A4 paper.

**Lamborghini Aventador**  
Cutting Shape for underbody panel rework 470825211C



Cut out the shape and use it as pattern to mark underbody panel portions to be modified. Refer to instructions detailed in technical bulletin nr. 887X-xx-xxx.

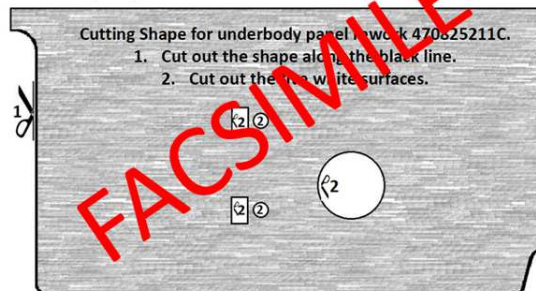

Place the stencil on the floor panel aligning the outer edge then mark the position of the 5 holes.



Perforate the floor panel at the positions indicated with a felt tip marker using a mill cutter.

Install the two speed nuts (p.n.N90170803) in the holes drilled on the floor panel.

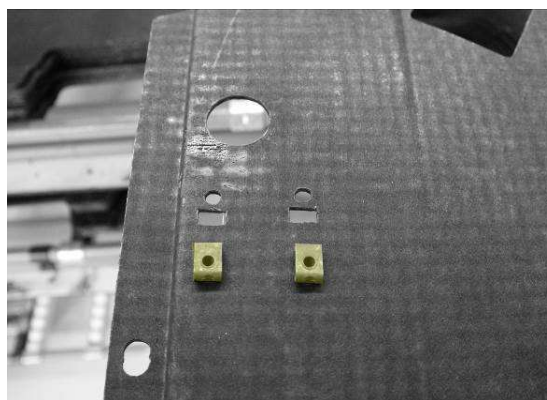

Rev.01

The information and procedures published below are strictly confidential and intended exclusively for authorized operators and individuals. All copyrights are the property of Automobili Lamborghini S.p.A based on copyright law. The company reserves the right to make updates and modifications. The reprinting, reproduction, forwarding to unauthorized people and/or to third parties and partial or entire translation thereof are prohibited without written authorization from Automobili Lamborghini S.p.A.

doc. nr: L/V6\_M06 Rev.[04]

31/58



Fix the plastic nolder (p.n.470825296) in the two openings using the speed nuts (p.n. N90170803) and the screws (p.n. N90986803).

Tighten the screws.  
 Tightening torque: **3Nm**.



Position the floor panel in the vehicle and check that the opening made on the component coincides with the fuel vapor exhaust pipe position.

The breather tube must be in the center of the opening made on the floor panel and must not be obstructed.



If the fuel vapor exhaust pipe is obstructed by the floor panel, widen the opening made under point 60 of this procedure.

### FLVV valve update.



#### Note.

Clean the work area and the various components before carrying out the disassembly operations. Make sure no dirt or other material can contaminate the fuel vapor circuit.



#### Note.

Fire hazard: do not work in the presence of open flames or tools that may ignite fires. Always keep a fully operational fire extinguisher at the ready.

### 61. Emptying of the fuel tank.



#### Note.

This operation will enable the emptying of both the fuel tanks.



#### Note.

In order to use the fuel suction unit follow the instructions provided with the equipment.

In order to empty the fuel tanks use the tool suggested by Automobili Lamborghini **VAS 5190A**.

**Together with adaptor VAS 5190/10.**

#### Tool for tank emptying:

VAS 5190 A → ASE 435 040 01 000.

#### Adaptors:

**VAS 5190/10 → ASE 435 046 00 000.**

Remove the connector from the right fuel tank as shown in the figure.





Use the appropriate connector to connect the fuel suction unit to the tank.



Use the fuel suction unit to empty the tanks.



73x13\_0003783

Once the tanks are empty remove the equipment and reconnect the fuel connector that was previously disconnected.



**Note.**

Verify the correct engagement and fixing of the quick couplings of the fuel vapor circuit hoses.



62. Removing the right tank fuel filter.

Remove the fuel hose from the right fuel tank as shown in the figure.



**Note.**

Take care not to damage the hoses or quick couplings during disassembly.



Remove the fuel hose from the right fuel tank as shown in the figure.



**Note.**

Take care not to damage the hoses or quick couplings during disassembly.



Remove the electrical cabling from the right fuel tank.



**Note.**

Take care not to damage the electrical connectors during removal. Replace the connector in the case of damage.

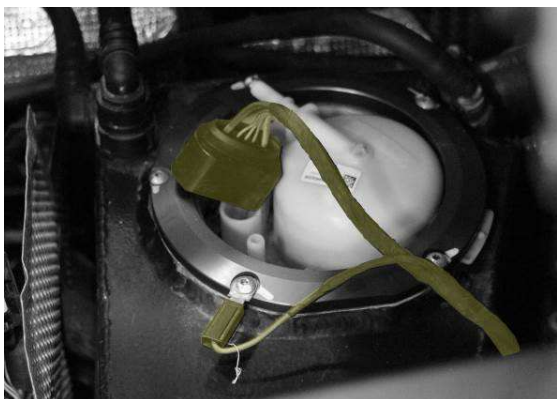

To remove the power connector, lift the break-in prevention feature and then press it as shown in the figure.



After removing the hoses and electric wiring, unscrew the 5 screws securing the fastening ring.



**Note.**

The screws have been fastened using threadlocker. Before removing them dislodge them with a hammer of suitable proportions. Use a hammer with a 200gr. maximum impact mass. Be careful not to damage the screw heads.



**Note.**

If the tank threads are damaged the entire component must be replaced.



Remove the ground connector secured to the fastening ring (shown in red).

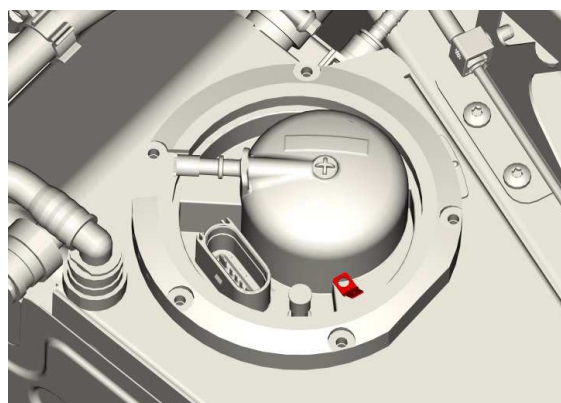

Remove the fuel filter fastening ring.

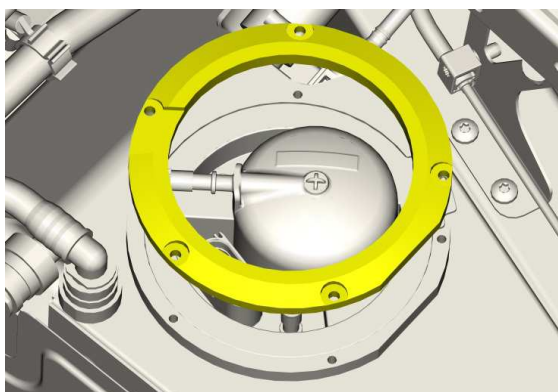

Lift the filter then position it so that you have easy access to the tank's internal components.

Remove the tank's gasket (shown in red).



Note.

This component must be replaced after disassembly.

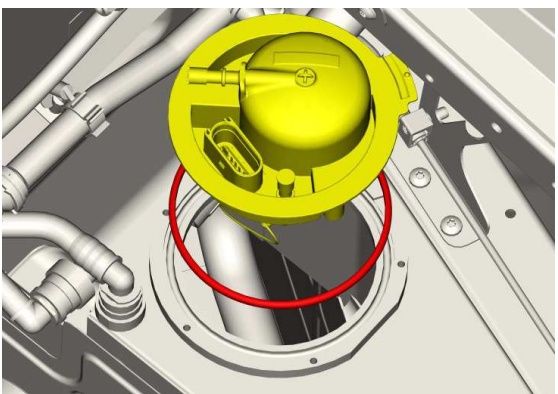

### 63. FLVV valve disassembly.

Access the inside of the tank and remove the two nuts and two fastening rings that secure the FLVV valve.

The nuts that secure the FLVV valve inside the tank are M5 and fit an 8 mm wrench.

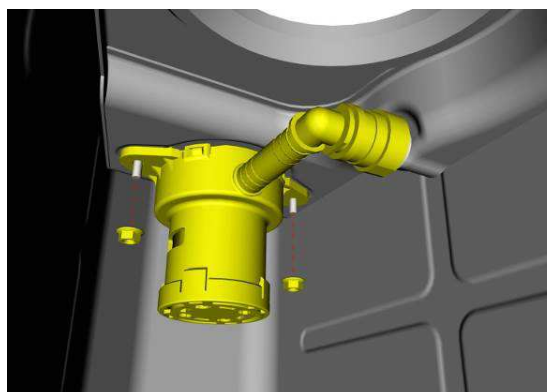

Note.

Do not allow nuts or fastening rings to be left inside in the tank. If lost inside the tank, the components must be necessary recovered using a magnet.

Rotate the FLVV valve as shown in the figure.



Open the quick coupling as shown in the figure and remove the FLVV valve from the tank.





The picture below shows how to extract the old FLVV valve to be replaced.



#### 64. Installation of the new FLVV valve.

Insert the new updated FLVV valve (p.n. 470201521D) inside the tank.



Insert the quick coupling then position the valve correctly inside the tank and complete the installation by securing using the flange nuts and the fastening rings removed under point 63 of this procedure.

Tighten the nuts.  
 Tightening torque: **2Nm**.



#### Note.

During the assembly of the FLVV do not exceed the prescribed pressure torque.



#### Note.

Verify the complete engagement of the quick coupling of the FLVV valve. Verify the correct engagement ex-

erting a gentle traction with two fingers. Replace the valve if the quick coupling malfunctions.

#### 65. Installation of the right tank fuel filter.

Position the new gasket (p.n.470201209).

Position the fuel filter in its appropriate position as shown in the figure. Align the filter with the seat on the tank to ensure correct assembly.

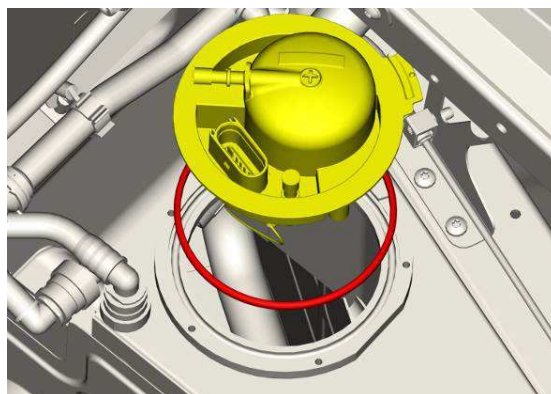

Install the fuel filter fastening ring as shown in the figure. Align the fastening ring with the tank to ensure correct assembly.

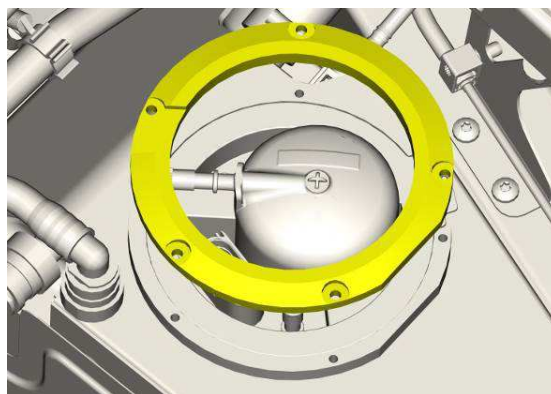

Position the connector of the ground point as shown in the figure.

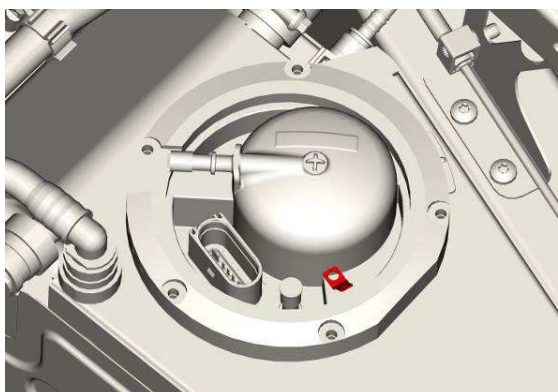

Fix the filter fastening ring with the 5 M5 screws (p.n. N10430104).

Tighten the screws.

Tightening torque: **5 Nm**

Use medium threadlocker LOCTITE 243, 2400 or equivalent.

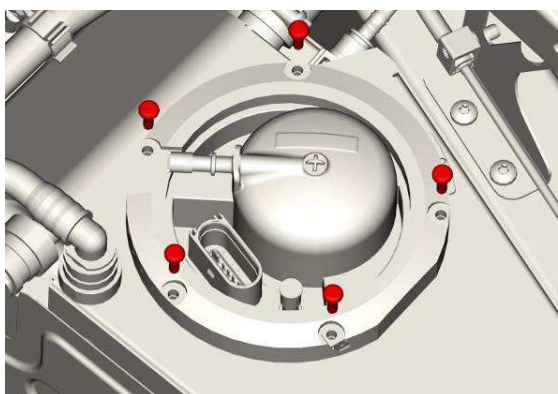

Connect the electrical cables as shown in the figure.



**Note.**

Once the assembly has been completed check the electrical connection between the tank screws and an unpainted part of the bodywork using a multimeter. The resistance value detected should read 0 Ω.

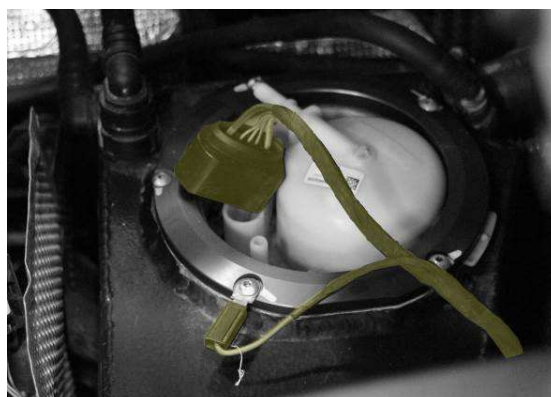

Connect the fuel pipes as shown in the figure.



**Note.**

Verify the correct engagement and fixing of the quick couplings of the fuel vapor circuit hoses.



Connect the fuel pipes as shown in the figure.



**Note.**

Verify the correct engagement and fixing of the quick couplings of the fuel vapor circuit hoses.



### Purge electro-valve update.



#### Note.

Clean the work area and the various components before carrying out the disassembly operations. Make sure no dirt or other material can contaminate the fuel vapor circuit.

#### 66. Purge electro-valve identification.

Mark the hoses and their position with regard to the Purge valves with two different colors (white and yellow), as shown in the figure. Continue in the same way for the electrical connectors of the valves. This operation is to ensure the connections are not inverted during removal and reinstalling.

Mark in white the purge and related hose of 1-2-3-4-5-6 cylinder bank.

Mark in yellow the purge and hose of 7-8-9-10-11-12 cylinder bank.



#### Note.

Do not invert the connectors and the hoses connected to the 2 electro-valves.

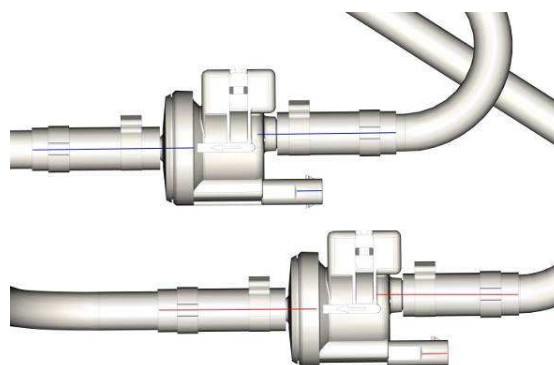

Pay attention to the assembly direction of the old purge valves on the hoses. The flow of the valves is indicated by an arrow printed on each one of them. The new valves must be oriented like the old ones.



### 67. Disassembly of the purge electro-valves.

Detach the fuel vapor hoses from the ACC filter bracket.

Remove the purge electro-valve metal hose clamps, disconnect the electrical connectors then remove the 2 purge electro-valves from the fuel vapor hoses.



#### Note.

Only remove the clamps that hold the purge electro-valves.



#### Note.

After removal these components must not be reinstalled on the vehicle.

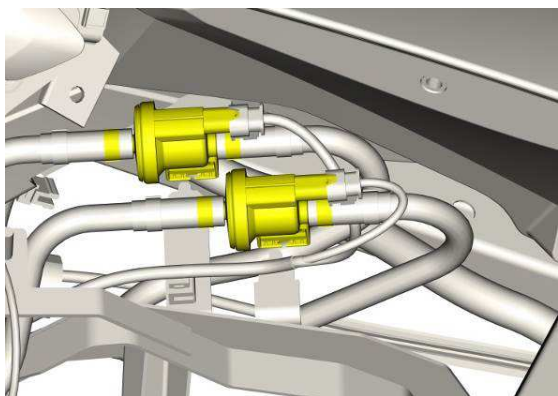

### 68. Installation of new ACC electro-valves.

Install the new ACC electro-valves (p/n. 06H906517AB) on the hoses as shown in the figure.

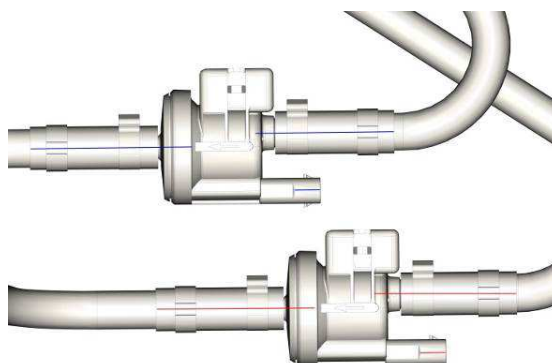

The flow of the valves is indicated by an arrow printed on each one of them. Orient the valves as shown under point 66 of this procedure.

Fix the electro-valves to the hoses using the hose clamps provided (p.n. N10199201).



#### Note.

Do not invert the connectors and the hoses connected to the two electro-valves.

Fix the hoses to the ACC filter bracket.

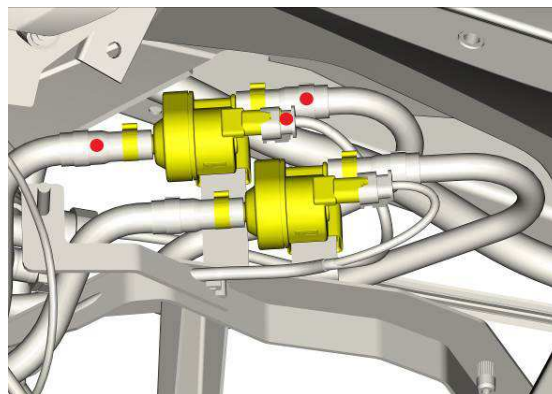



**Tank cap update.**

**Only for those vehicles included between CLA000091-HLA05374.**



**Note.**

Clean the work area and the various components before carrying out the disassembly operations. Make sure no dirt or other material can contaminate the fuel vapor circuit.

69. Removing the fuel tank cap.



**Note.**

Work in a well-aired environment.

Remove the fuel tank cap then unhook the holding cable

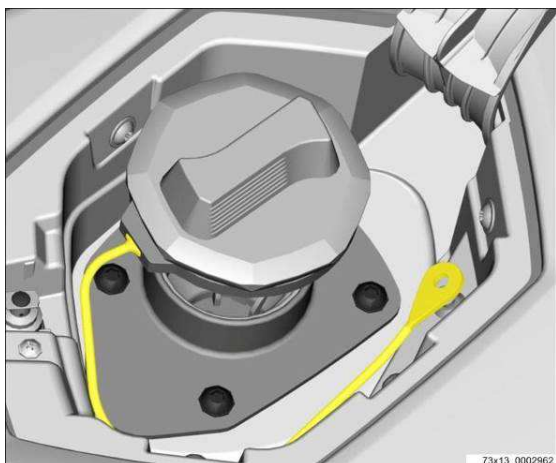

70. Wrap the point of an average sized flat screwdriver in cloth tape.



**Note.**

This operation is performed in order to avoid damaging the aluminum part of the cap during disassembly.



71. Disassembly Fuel tank cap.

Position the cap as shown in the figure and identify one of the three aluminum slots that hold the plastic part.

Insert the point of the tape-clad screwdriver into one of the openings located on the plastic part and prise upwards.



**Note.**

Be careful not to dent the aluminum part. The openings are present along the entire perimeter of the plastic cap.





Remove the plastic part completely from the aluminum cap.



Remove the fastening ring inside the aluminum cap.

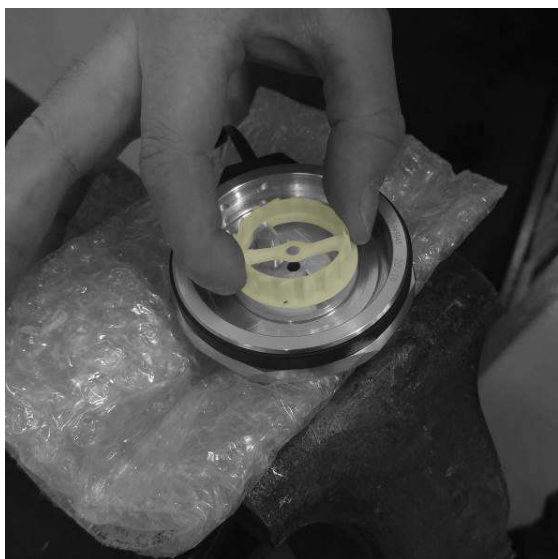

72. Assembly Fuel tank cap.



**Notice**

Avoid crushing or damaging the lower part of the component as it is highlighted in the pictures. In case of damages the parts need to be replaced.



Position the new plastic part of the cap on a socket wrench with a 27mm internal hexagon as shown in the figure.



**Note.**

Perform this operation in order to avoid damaging the component.



Place the fastening ring inside the new plastic part.

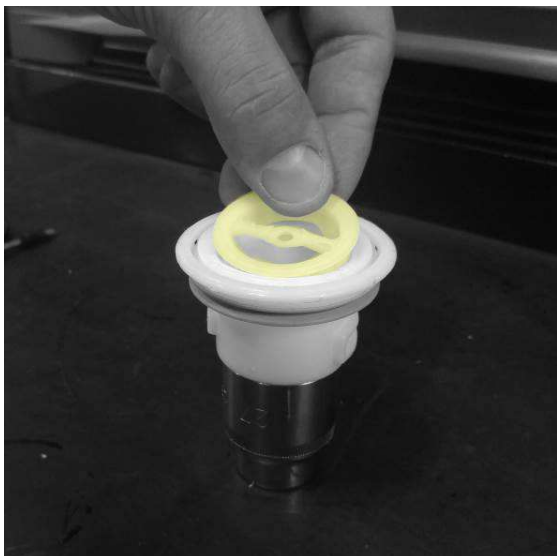

Position the aluminum cap over the plastic part.



**Note.**

Take care to slot the two aluminum pins inside the openings found in the plastic fastening ring.

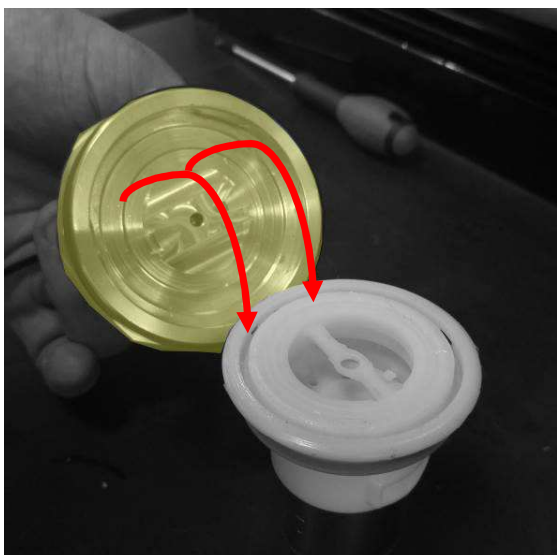

Press on the aluminum part manually until the two components snap together.

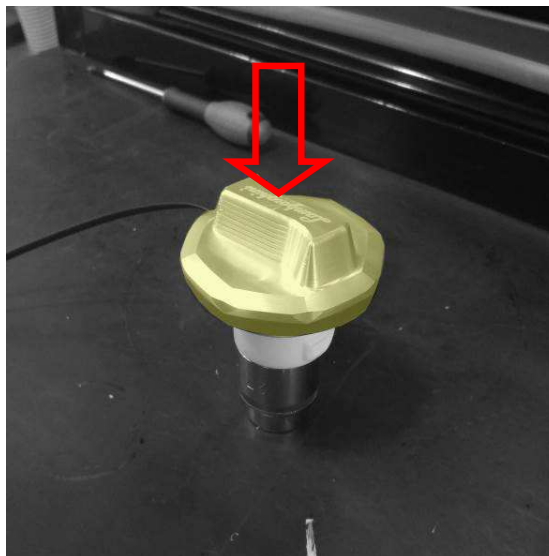

Verify the correct assembly of the two components and the operation of the snap clutch.

Holding the aluminum cap firmly, the plastic part should be able to rotate clockwise and make the snap clutch snap.

Holding the aluminum cap firmly, the plastic part should not be able to rotate counter-clockwise more than 180°.



73. Assembling the fuel tank cap.



Reposition the safety cable on the cap then install the cap on the vehicle and close the filler flap.

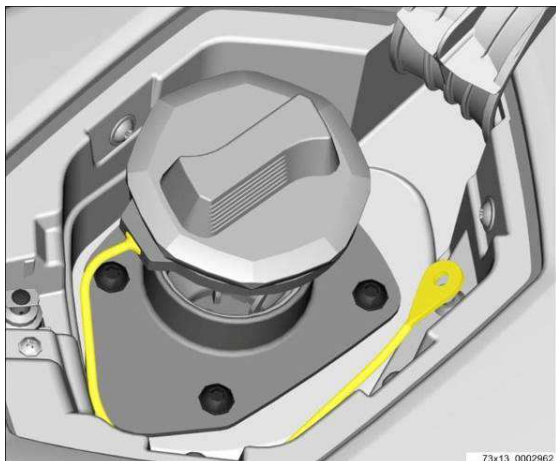

### Final operations:

#### 74. Fuel tank seal test.

Follow the instructions below to verify the correct assembly of the fuel tank cap and ensure that the fuel vapor circuit is leak-tight.

To perform this operation use the following special equipment:

- Seal test device p.n. 61353000375 0-40mbar
- Seal test device connector p.n. 61353000397



#### Notice.

the kit 61353000375 includes two leak testers:

- The tester with 0-40 mbar manometer is to be used only on AVENTADOR.
- The tester with 0-400 mbar manometer is to be used only on HURACAN.

**Do not exceed the pressure of 0.02 bar during the test.**



#### **Rischio di danneggiamento!**

Impiegare l'attrezzò errato può comportare danni al serbatoio o





- a) Perform the fuel tank seal test device 61353000375 test as follows:

Connect the connector (A) of the fuel tank seal test device to the compressed air system pipe.

Open the shut-off valve (B).

Read the instrument reading: nominal value 0.02 bar (0.3 psi).

Close the shut-off valve (B).

During the next two minutes the pressure shown on the pressure gauge (C) must not go below the nominal value.

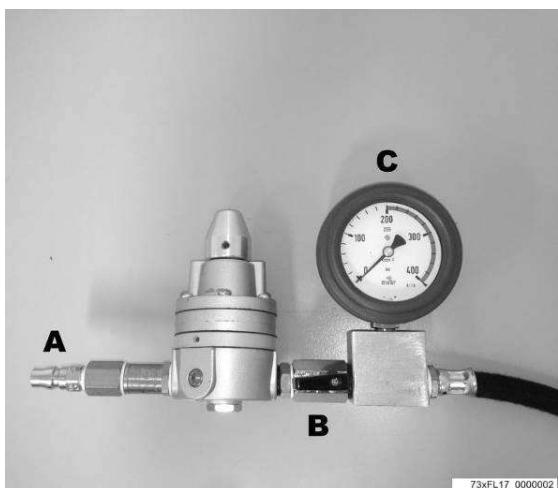

- b) Disconnect the fuel vapor hose from the vehicle's canister filter.



- c) Connect instrument 61353000397 as shown in the figure.

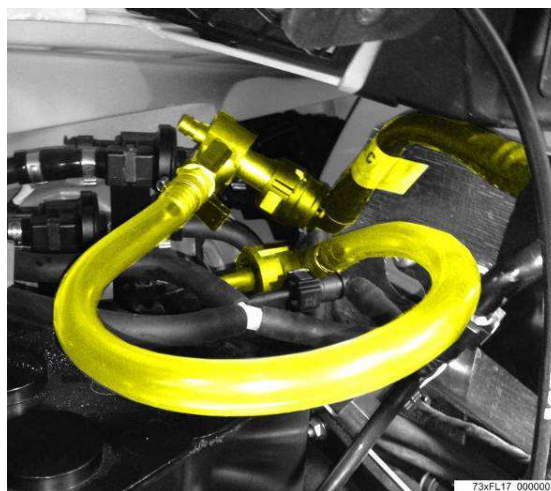

- d) Close the shut-off valve (position 0).

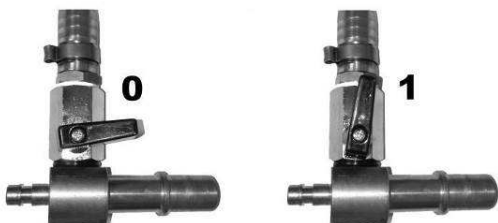

73xFL17\_0000003

- e) Connect the fuel tank seal test device 61353000375 to instrument 61353000397.



73xFL17\_0000007

- f) Open the shut-off valve (position 1) and wait for the system to charge up. The pressure must stabilize at a value of around 0.02 bar (0.3 psi).

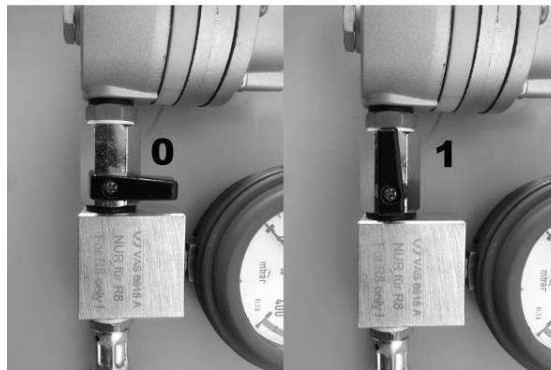

73xFL17\_0000006

- g) Close the shut-off valve (position 0) and check that in the next two minutes the pressure doesn't drop below the previous reading of 0.02 bar (0.3 psi)

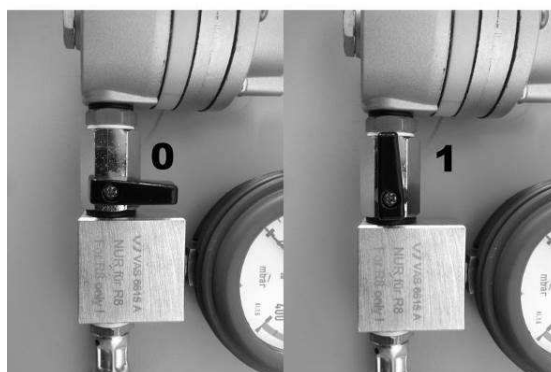

73xFL17\_0000006



**Note.**

If the pressure goes below the set value, the tank system has one or more leaks: it will therefore be necessary to look for leaks in the system with a leak detector spray. If, on the other hand, the pressure remains stable at the set value, this means that the system has no leaks.

- h) After performing the seal test, discharge the pressure in the system by opening the shut-off valve (position 1).

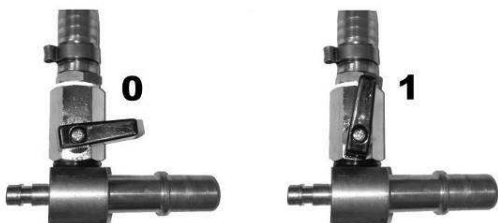

73xFL17\_0000003

- i) Remove the instrument 61353000397 and the tank seal test device 61353000375.
- j) Reconnect the hose removed at point 74/b of this procedure.



73xFL17\_0000004

- 75. Refuel the vehicle with the fuel removed at point 61 of this procedure.



**Note.**

Refuel through the fuel filler.

- 76. Complete vehicle reassembly.

**To complete vehicle reassembly carry out the instructions provided in this bulletin from point 1 to point 27 in the reverse order.**

**Software update.**



The instructions contained in this bulletin are based on ODIS Service diagnosis software updated to release 3.1.3 (or following) and database Lamborghini 2.10.0 (please refer to BI.07.15 and be sure that ODIS service on your laptop is up-to-date)

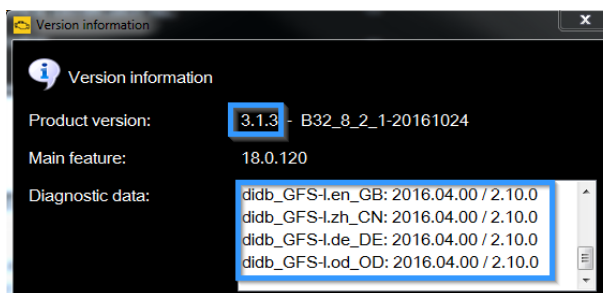

**Preliminary operations:**

- 77. Make sure to be recently synchronized with Mirrorserver by checking the Last Sync date under:

<http://mirrorserver/maintenance/diagnosis.py>

or directly inserting your Btac-box IP address:

[http://\[IP\\_address\]/maintenance/diagnosis.py](http://[IP_address]/maintenance/diagnosis.py)

if you have not previously set up the mirror-server IP alias.

(e.g. <http://12.34.567.890/maintenance/diagnosis.py>)



**IMPORTANT**

Make sure the last synchronization has been done after **the 24<sup>th</sup> of February 2017.**



MS/2 Diagnosis

Configuration	
Base path	/var/www/desert
Provider URL	https://altair.mirrorserver2.net/deployment
Repository URL	https://altair.mirrorserver2.net/storage
Feedback URL	https://altair.mirrorserver2.net/health
Proxy	10.48.187.43
Key file	/var/www/desert/certs/userkey.pem
Certificate	/var/www/desert/certs/usercert.pem
Tests	
Local file/directory permissions	OK
Disk space	OK
Provider reachable	OK (altair.mirrorserver2.net)
Repository reachable	OK (altair.mirrorserver2.net)
Feedback reachable	OK (altair.mirrorserver2.net)
Provider WebDAV access	OK (https://altair.mirrorserver2.net/deployment)
Repository WebDAV access	OK (https://altair.mirrorserver2.net/storage)
Feedback WebDAV access	OK (https://altair.mirrorserver2.net/health)
Successful package downloads	9
Failed package downloads	0
Last Sync	15/12/17 22:09:13
<input type="button" value="Start tests"/>	



**IMPORTANT!**

If instrument cluster ECU has to be updated, it is necessary to take note of distance and days to next service, shown in the instrument cluster menu.

(e.g 3400 km and 200 days)



**Updating Procedure:**

78. Please connect a battery charger to the recharge points available in the engine bonnet, as shown in picture.

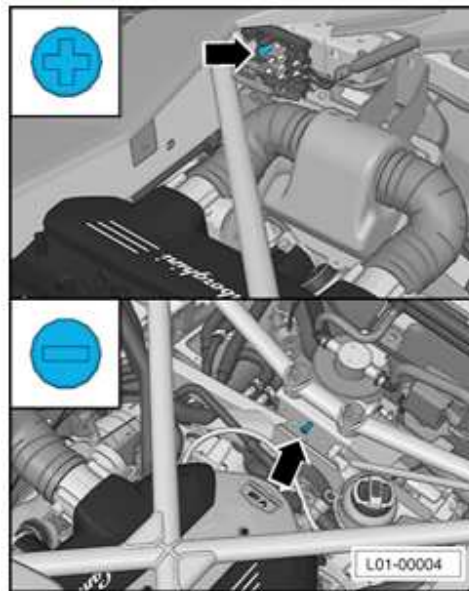

79. Start ODIS service and complete the preliminary operations as described in chapter **10.00.ODIS preliminary operations**.



**IMPORTANT**

Please correctly identify the vehicle selecting the right Variant (coupe or roadster) and Engine Type (515 – 530 or 552 kW).

Leave the checkbox “Using guided fault finding” marked.

L73X-  
R.01.17

To:  
Subject:  
Date:  
Pages

Official After Sales Network  
Evap system update  
February 23, 2017  
58

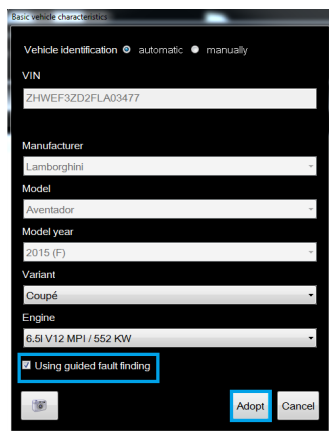

80. At the end of the start-up procedure move on the ODIS tab “special functions”.

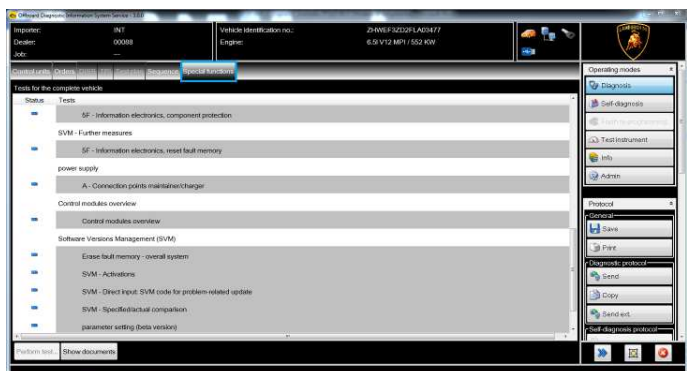

81. Select “SVM – Direct input: SVM code for problem related update” clicking the related row.

Click “Perform test...” to execute the SVM function.

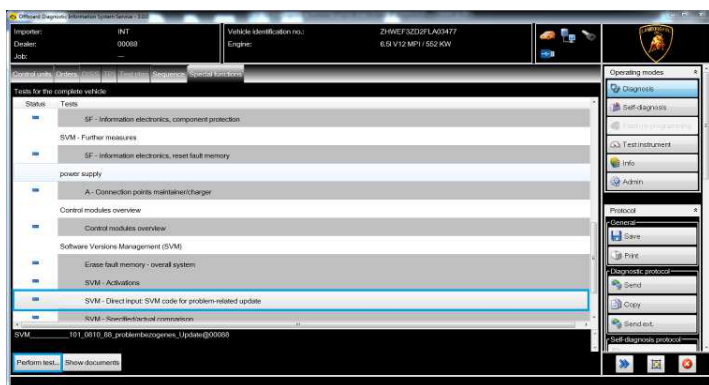

82. Insert in the upper box with the cursor the code:

**L73XR0117**

Click “Adopt”

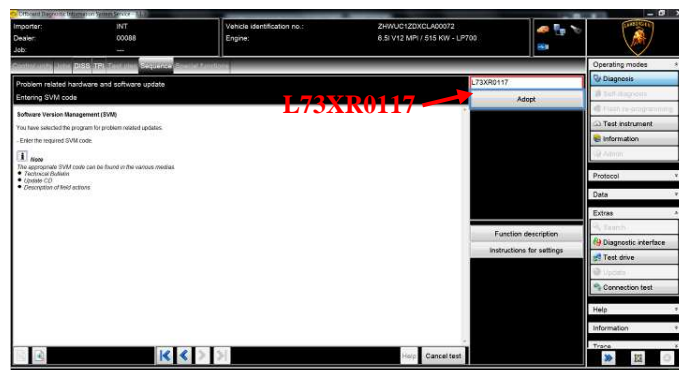

83. Click “Yes” to confirm the code inserted is correct and follow the instructions.

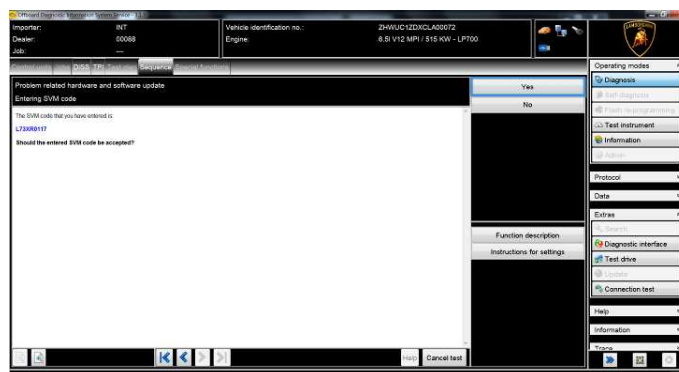

The complete guide in order to perform an SVM code is available in the workshop manual, chapter **10.00.Running an SVM code.**

84. Once the SVM has been completed, go back to the tab “Special functions” and select “Erase fault memory – overall system” to clear all the faults stored because of the recent software update.

The complete guide in order to erase all fault memories is available in the workshop manual, chapter **10.00.Deleting the data in the fault memory of control units**



L73X-  
R.01.17

To: Official After Sales Network  
Subject: Evap system update  
Date: February 23, 2017  
Pages: 58



/\* Adaptation After Software Updates \*/



**IMPORTANT**

Adaptation is frequently necessary at the end of a control unit software update and following fault memories removal.

85. Go to Control Unit tab to select the gearbox ECU GET\_02 guided function:

“02 – ECU setup after replacement / software programming”

Click “Execute”.

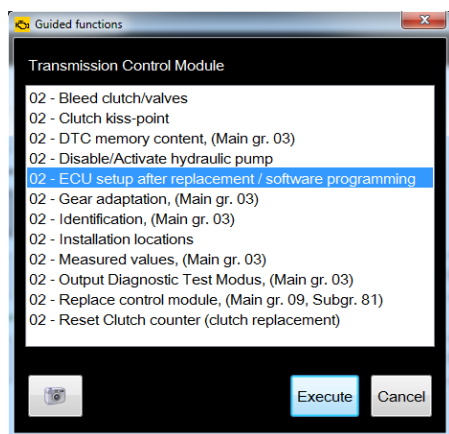

86. Click “Done/Continue”.

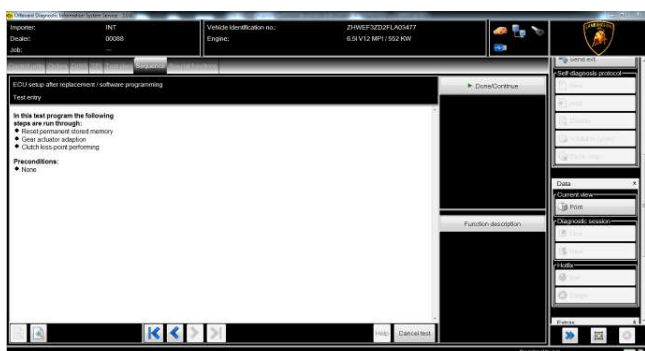

87. Click “Done/Continue”.



88. Click “NO”

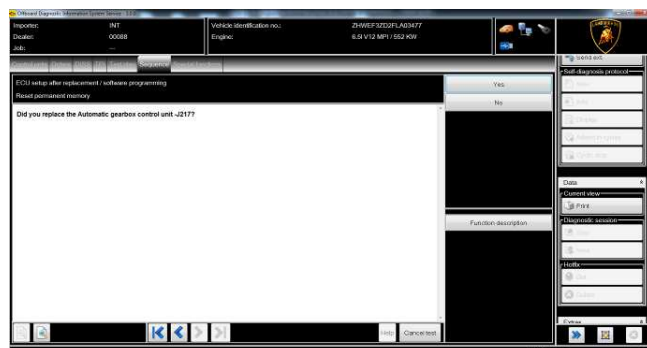

89. Click “Done/Continue”.

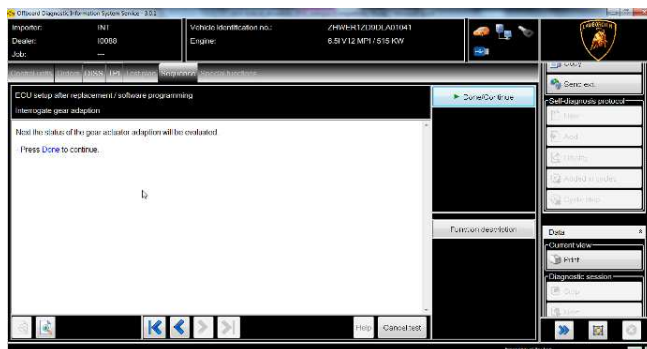



90. Read the conditions to perform the test and click “Done/Continue” .

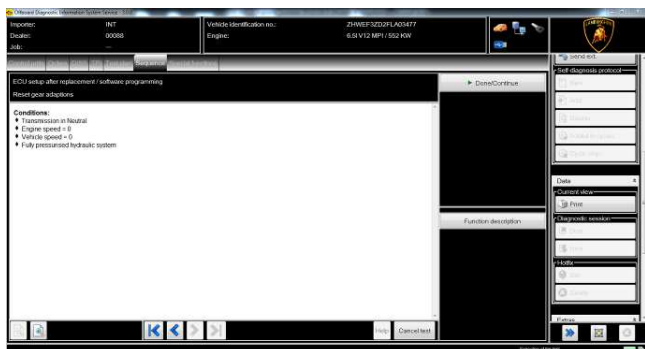

91. Click “YES” to start the basic setting.

You can check on the instrument cluster the gear shifting.



92. Click “Done/Continue” to evaluate the gear actuator adaption.

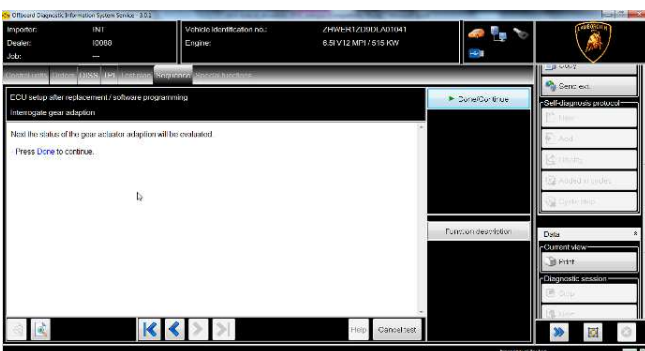

93. Click “Done/Continue”.

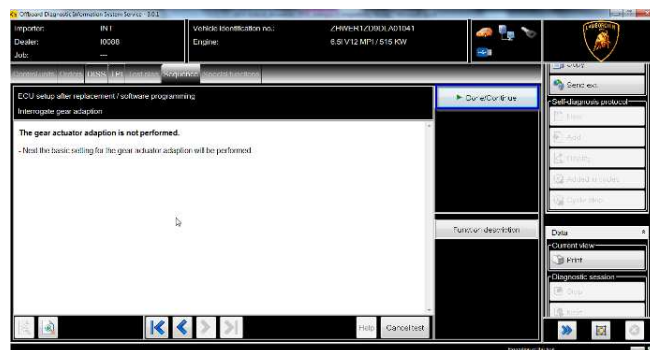

94. Click “Done/Continue” to perform the clutch kiss point test.



95. Press the brake pedal and start the engine.

Keep the brake pedal pressed until the end of the basic setting. (approx. one minute).

If you cannot turn the engine ON:

- Turn the key off;
- Disconnect the diagnosis interface;
- Wait at least one minute before turning the key on again;
- Connect the diagnosis interface again and start back from point 85.

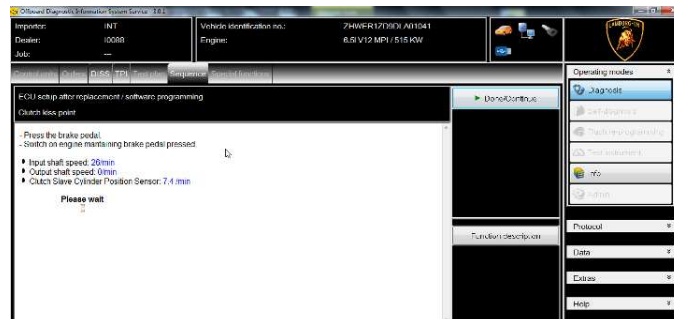

L73X-  
R.01.17

To: Official After Sales Network  
Subject: Evap system update  
Date: February 23, 2017  
Pages: 58



96. Click “Done/Continue” to end the test.

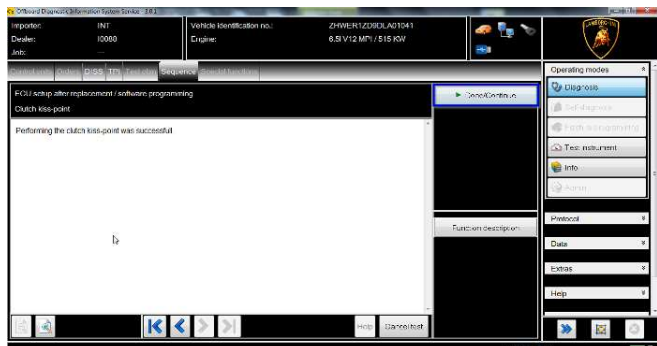

97. Go back to the Control Unit tab to select the Engine ECU MOT\_01 guided function:

01 – Reset adaptation values.

Click “Execute” to start the procedure to reset adaptation values (Basic Setting 254).

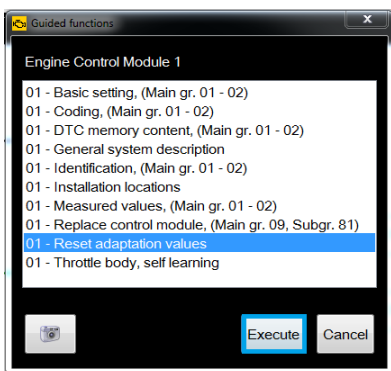

98. Click “Done/Continue”.

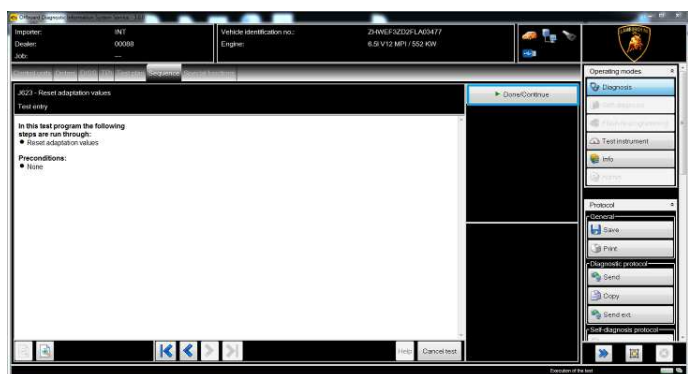

99. Click “Done/Continue”.



100. Make sure the activation conditions are respected:

- key ON;
- engine OFF;
- no faults stored in the Engine ECU memory.

Click “Done/Continue”.

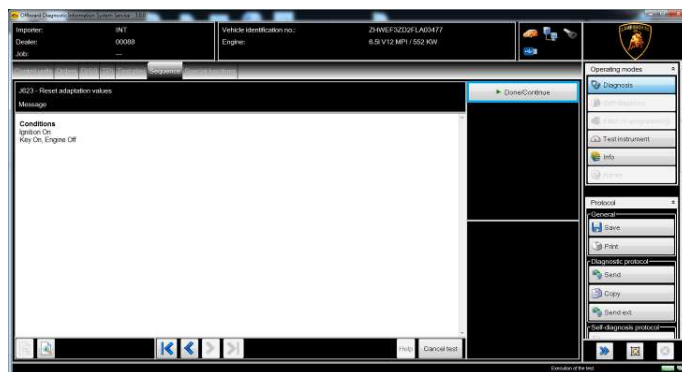

101. Click “Yes” to continue.

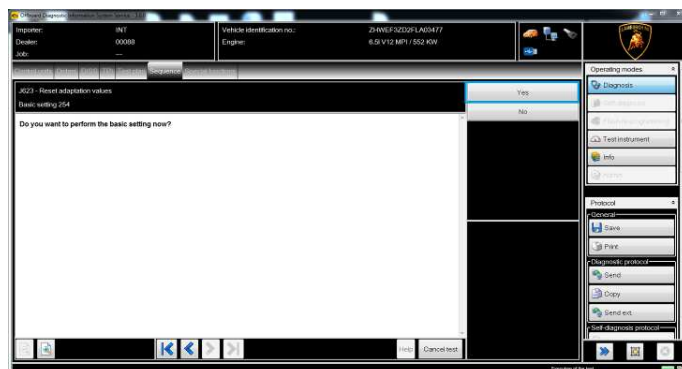

L73X-  
R.01.17

To: Official After Sales Network  
Subject: Evap system update  
Date: February 23, 2017  
Pages: 58



102. Click “Done/Continue” to perform the basic setting.

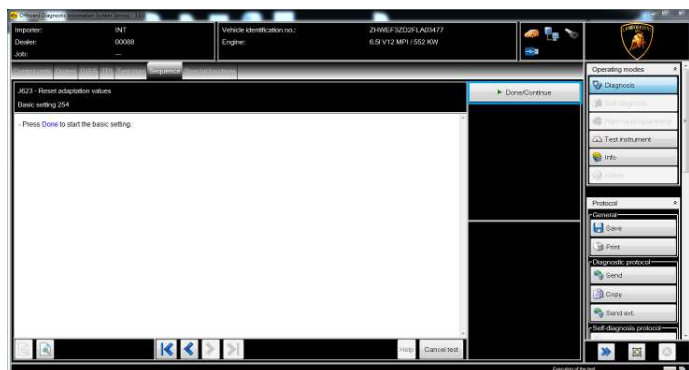

103. Wait until the feedback message is shown.

If the procedure has been performed successfully, the message “Syst.OK” will appear, as shown in the picture below.

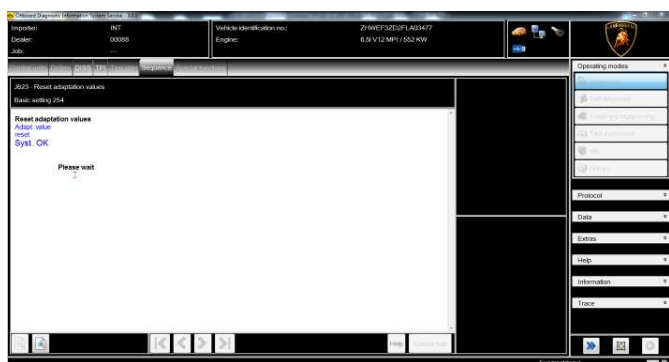

104. If the procedure has not been performed successfully:

- Turn ignition OFF;
- Wait at least one minute before turning ignition ON again;
- Repeat the procedure from step 97.

Click “Done/Continue” to exit the basic setting.

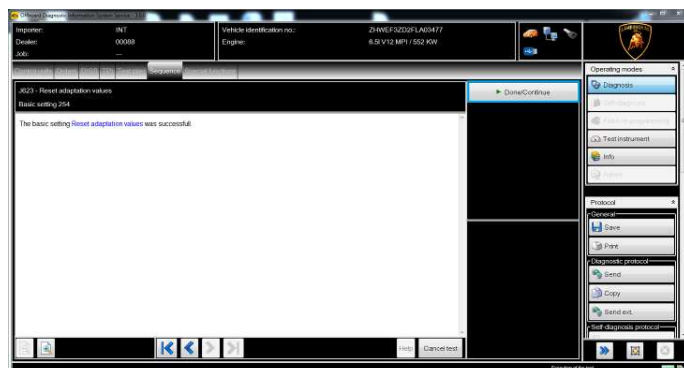

105. Go back to the Control Unit tab (block diagram or list view) to select the Engine ECU MOT\_01 guided functions .

Select “01 – Throttle bodies, self learning” function and click “Execute”.

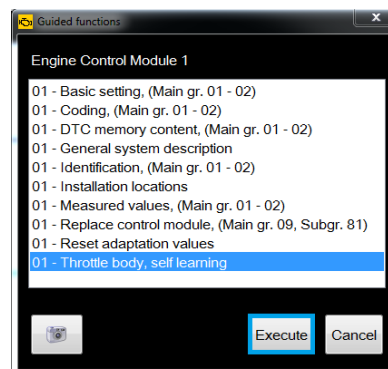

106. The requirements for the test are summarized.



**IMPORTANT!**

Make sure that air conditioning is OFF.

Click “Done/Continue”

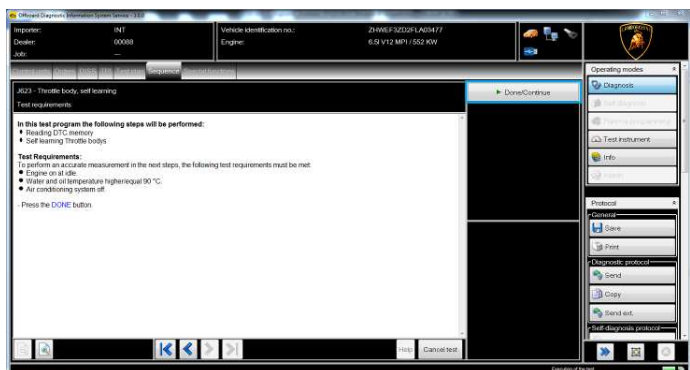

107. Start the engine at idle speed.  
Click "Done/Continue"

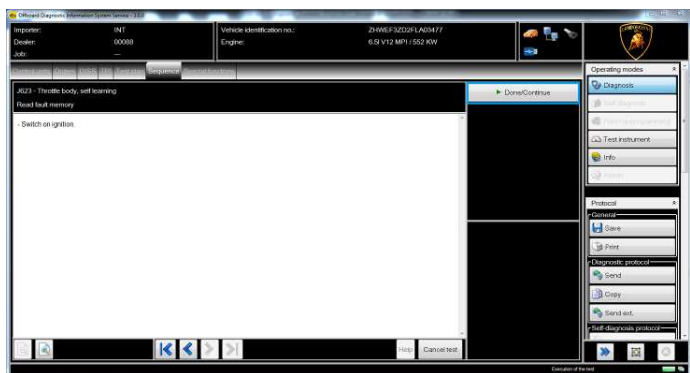

108. If you did not switch air conditioning OFF a warn-  
ing message will appear.  
Turn air conditioning OFF and click "Yes".

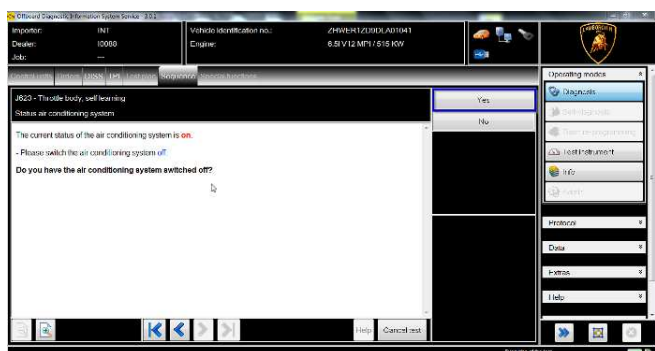

109. Self-learning is an automatic procedure which is  
activated when engine water and oil temperature reach  
90 °C.

Check the parameters from ODIS and wait until water  
and oil temperatures reach the target.

Don't perform any action on the car (e.g. pushing the  
accelerator pedal) if not necessary.

Once the conditions are met (water and oil temperature  
above 90°C) the "Throttle body – Self learning ena-  
bling conditions flag" switches from 0 to 1 indicating  
the beginning of the self-learning procedure.

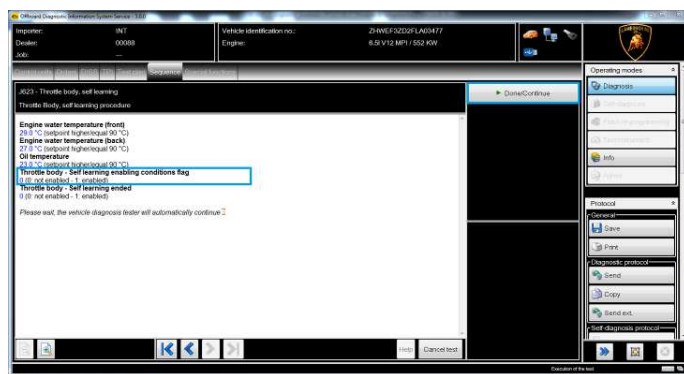

110. If the self-learning has been completed successful-  
ly a screen as in the picture below is shown.

Click "Done/Continue" to display the ignition advance  
values.

If the procedure has not been completed correctly:  
Switch the ignition OFF;

Wait one minute before switching the ignition ON  
again;

Restart the procedure from step 105.

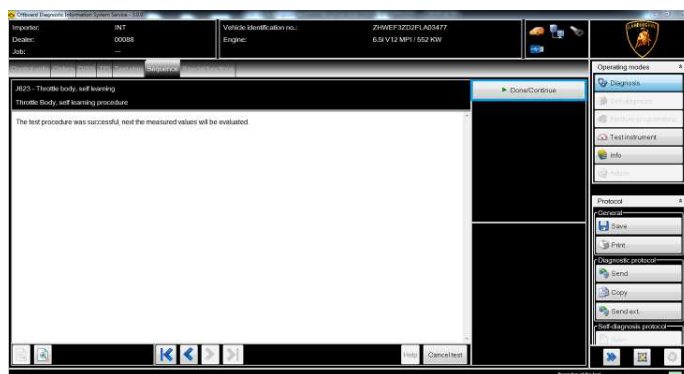

111. Ignition advance values must be inside the range [-  
2° 3°].

L73X-  
R.01.17

To: Official After Sales Network  
Subject: Evap system update  
Date: February 23, 2017  
Pages: 58



Switch the engine OFF and press “Done/Continue” to exit the program.

If these values were out of the range restart the procedure from step 105, leaving ignition Key OFF for at least one minute .

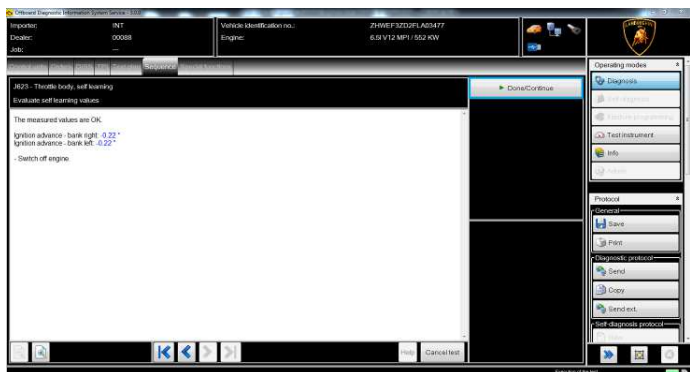

112. Click again “Done/Continue” to exit the test.

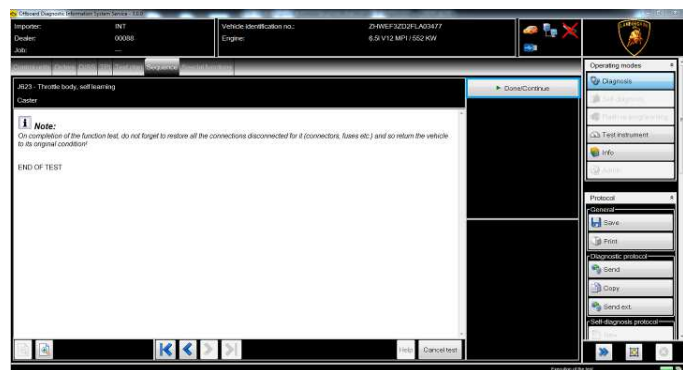

#### /\*Basic Settings\*/

113. In order to verify the correct execution of the updating procedures, please run the following basic settings for the Engine ECU 01-MOT:

- 2- Canister purge (EAVP)
- 7- Secondary air injection leak detection pump (Air-LDP)

#### J623 - Basic setting

##### Selection 1

Which basic setting do you want to perform?

- 1- Throttle valves (DBW)
- 2- Canister purge (EAVP)
- 3- Camshaft adjustment intake (VVT intake)
- 4- Camshaft adjustment exhaust (VVT exhaust)
- 5- Lambda oxygen sensors before and after catalyst
- 6- Exhaust temperature control system (ETCS)
- 7- Further basic settings
- 8- End test

#### J623 - Basic setting

##### Selection 2

Which basic setting do you want to perform?

- 7- Secondary air injection leak detection pump (Air-LDP)
- 8- Lambda oxygen sensors before catalyst efficiency
- 9- Catalyst efficiency
- 10- Fan actuator test
- 11- Variable Intake System (VIS) actuator test
- 12- Throttle valves (Self learning DBW)
- 13- Back to previous selection
- 14- End test

114. The complete guide in order to perform the basic settings for the engine ECU is available in the workshop manual, chapter 10.01. **Description of Guided diagnostic functions with ODIS Service - Basic Settings.**

115. If it is necessary to restore service time and distance intervals:

select “self-diagnosis” in the right menu.

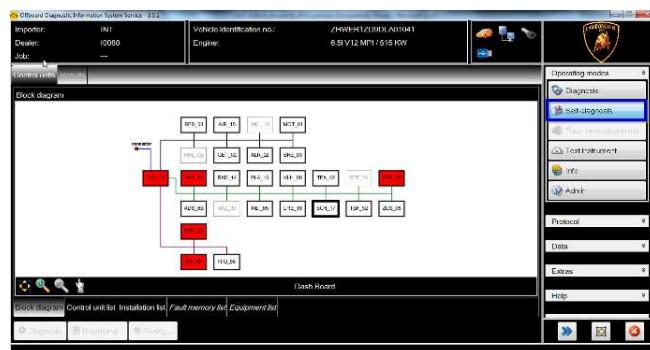

116. Right click dash board ECU and select Control Unit self-diagnosis.

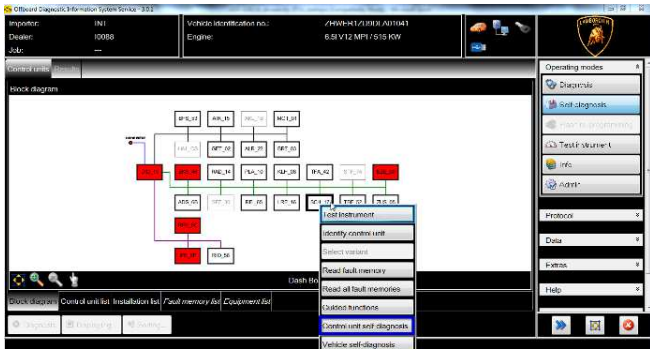

117. In the following menu select Adaption and click “Execute”.

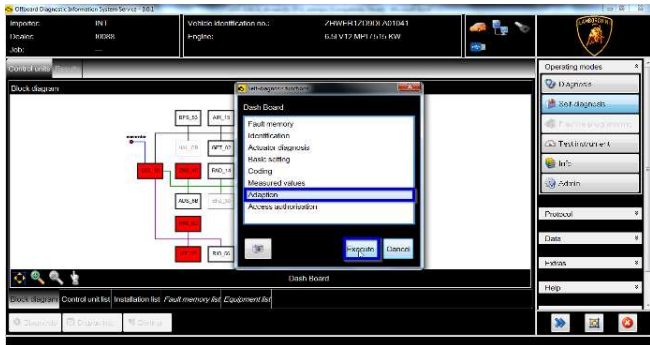

118. Write “52” in the channel box and click “Select channel” as shown in the picture.

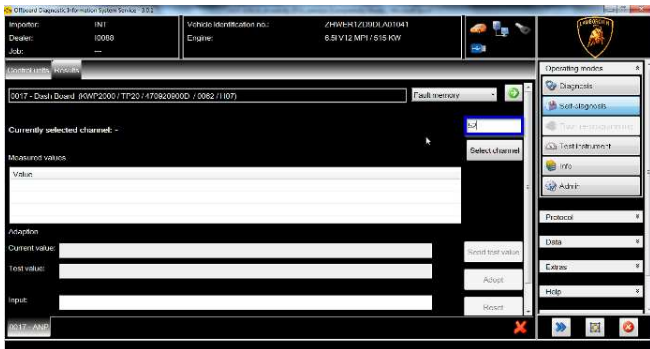

119. Insert the distance to next service divided by 100 in the input box.  
(e.g. write 150 for 15000 km to next service)  
Click “adopt”.

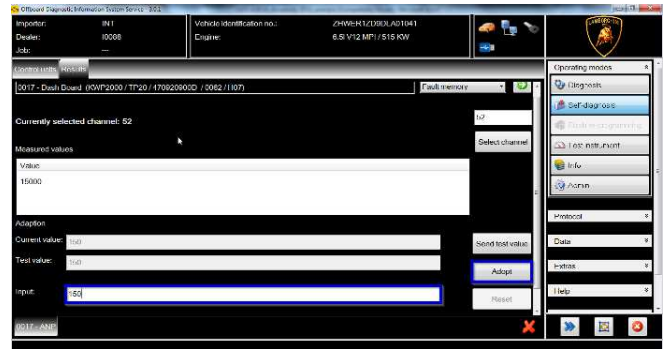

120. Write “54” in the channel box and click “Select channel”.

Then insert the days to next service in the input box.  
(e.g. write 365 for 365 days to next service)  
Click “adopt”.



**/\* Diagnosis protocol saving \*/**

121. At the end of software updates, save the diagnostic protocol as described in chapter 10.00.ODIS Saving the diagnostic protocol.



**IMPORTANT**

The diagnosis protocol has to be attached to the related Warranty Claim

(in order to insert the claim on the Web Portal, please refer to Warranty Claim Manual you can find under the Portal, Warranty section).

L73X-  
R.01.17

To:  
Subject:  
Date:  
Pages

Official After Sales Network  
Evap system update  
February 23, 2017  
58



## Trouble shooting

A. If the error message regarding the VAS5054 interface and the two icons for status of on board connection and key ON are shown as in the picture below:

- Click “Cancel”;
- Repeat the VAS5054 HW interface installation following the procedure (\*) “VCI Manager v2.0”, by entering in the menu “Extras” on the right side and clicking on “Diagnostic interface”.



B. If one of the connection error screens is shown as in the pictures below:

- it is not possible to establish a connection with the central server. Please check carefully that the diagnosis laptop is properly connected to the internet network and retry clicking “Yes” or “Done/Continue”.

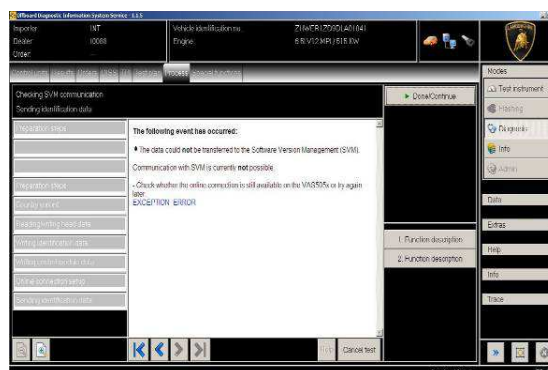
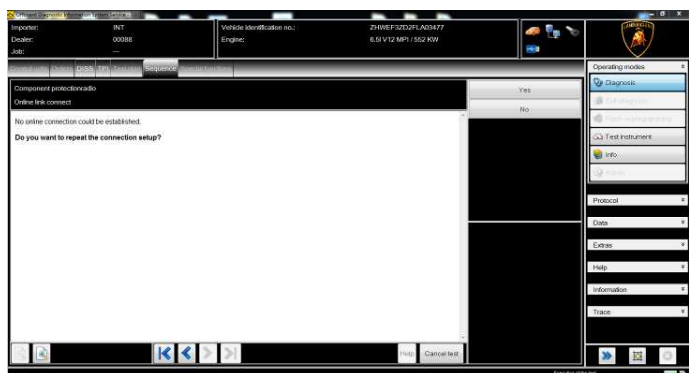

C. If the loss of connection happens during the target/actual comparison during SVM procedure:

- It is not possible to connect to central server, check the working connection of internet and retry by clicking “1”.



D. If the incorrect identification message is shown as in the picture below (error code: ODS1007E):

- be sure that your Geko account is valid;

E. be sure that the label “Geko” is written on the token that you are using for the authentication;

- be sure the Password inserted is correct;
- click on Cancel and perform the application test (see document “ODIS\_Checking\_ConnectionServer\_SVM\_2.0” (\*)).



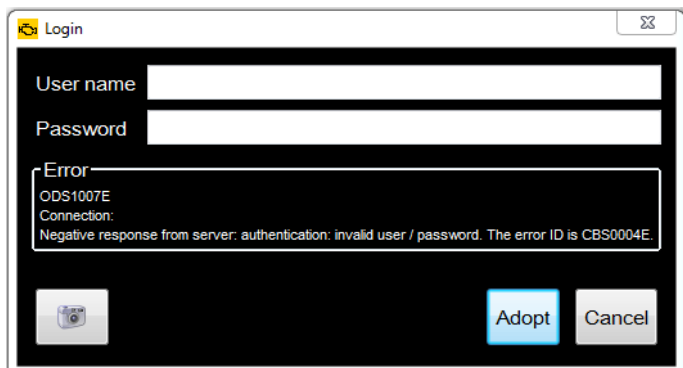

**F.** If the infrastructure error message is shown as in the picture below (error code: ODS9212E):

- be sure that your Geko account is valid
- be sure that the label “Geko” is written on the token that you are using for the authentication
- verify in ODIS settings you have “Internet” instead of “CPN” (see document “ODIS\_Initial\_Setup\_2.0” (\*))
- click on Cancel and perform the application test (see document “ODIS\_Checking\_ConnectionServer\_SVM\_2.0” (\*))

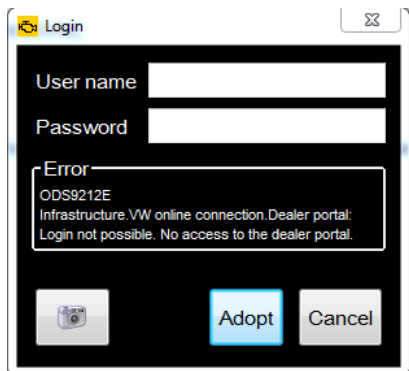

**G.** If the same error is present during the application test, try the following procedure:

- quit ODIS;
- Enter the folder C:\Program Files (x86)\Offboard\_Diagnostic\_Information\_System\_Service\automatic\_sessions on your diagnosis laptop;
- delete the only file present in that folder.
- re-Start ODIS Service under following conditions:

1. Network connection available;
2. ODIS connection set on “Internet”;

- Retry the application test and the SVM with your GeKO Token.



**IMPORTANT REMARK**

In the case an error is still present, retry the procedure with a second GeKO token, if available.

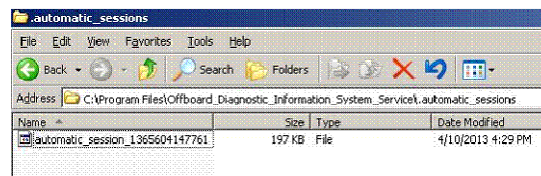

**H.** In the case the flash container is not detected (see figure):

- Make sure to be recently synchronized with Mirrorserver by checking the last date of Sync under:

<http://mirrorserver/maintenance/diagnosis.py>

or under

[http://IP\\_address/maintenance/diagnosis.py](http://IP_address/maintenance/diagnosis.py)

- if you don’t have previously defined the “mirrorserver” IP address alias.
- Make sure to be correctly connected with Mirrorserver.



MS/2 Diagnosis

Configuration	
Base path	/var/www/desert
Provider URL	https://altair.mirrorserver2.net/deployment
Repository URL	https://altair.mirrorserver2.net/storage
Feedback URL	https://altair.mirrorserver2.net/health
Proxy	10.48.187.43
Key file	/var/www/desert/certs/userkey.pem
Certificate	/var/www/desert/certs/usercert.pem
Tests	
Local file/directory permissions	OK
Disk space	OK
Provider reachable	OK (altair.mirrorserver2.net)
Repository reachable	OK (altair.mirrorserver2.net)
Feedback reachable	OK (altair.mirrorserver2.net)
Provider WebDAV access	OK (https://altair.mirrorserver2.net/deployment)
Repository WebDAV access	OK (https://altair.mirrorserver2.net/storage)
Feedback WebDAV access	OK (https://altair.mirrorserver2.net/health)
Successful package downloads	9
Failed package downloads	0
Last Sync	15/12/17 22:09:13



**NOTE.**<sup>(\*)</sup>

ODIS technical documentation can be retrieved on the Lamborghini web portal, under ODIS section.



**IMPORTANT REMARK:**

The documents to be mandatory attached to the claim are:

- Job order done;
- Diagnosis Protocol saved.

Failure to follow the procedures may lead to the rejection of the request.