



Mercedes-Benz

Campaign No. 2019110016, December 2019

Model 207 added 1-24-2020

TO: ALL MERCEDES-BENZ CENTERS

SUBJECT: **Model 204 and 207****Model Year 2012-2013****Replace Front Passenger-side Airbag**

Based on the defect decision of TK Holdings, Inc. ("Takata"), in certain passenger side airbags produced by Takata used in certain Model Year 2012-2013 Mercedes-Benz vehicles, under specific circumstances, the front passenger side airbag inflator housing may explode during deployment due to excessive internal pressure. This condition is more likely to occur if the vehicle has been exposed to high levels of absolute humidity for extended periods of time. A frontal passenger side inflator explosion during deployment could result in sharp metal fragments striking the passenger or other occupants, possibly causing serious injury or death. To remedy this concern, an authorized Mercedes-Benz dealer will replace the front passenger side airbag on the affected vehicles.

Prior to performing this Recall Campaign:

- **VMI must always be checked before performing campaigns to verify that the campaign is required on a specific vehicle. Always check for any other open campaigns, and perform accordingly.**
- Please review the entire Recall Campaign bulletin and follow the repair procedure exactly as described.
- **For more instruction on the SRS light – please see attachment A**

Approximately **74,724** vehicles are involved.

Order No. P-RC-2019110016

This bulletin has been created and maintained in accordance with MBUSA-SLP S423QH001, Document and Data Control, and MBUSA-SLP S424HH001, Control of Quality Records.

**WARNING!**

There is a risk of injury or death when performing testing or repair work on vehicles and when handling vehicle components. Be sure to read and observe all relevant safety instructions in WIS. This procedure must only be performed by trained personnel using proper tools and equipment.



Note: View the passenger-side airbag replacement videos prior to performing this procedure:

- **Location:** The Learning Link.
- **Course Code:**
 - X0070E-US.MTA (AKUBIS®: Passenger's Airbag Replacement)
- Video is for reference purposes, be sure to follow work sequence and instructions in this Procedure.



1. Load the **Mercedes-Benz PartScan** App. on Apple® i-Phone® or Android® smart phone.

**Note:**

- For Apple® iPhone® Users: The *MB PartScan* App is designed for generations of iPhone 5s and newer. However, for optimal experience and performance, we advise that an iPhone 6 and newer be used for scanning with the *MB PartScan* App.”
- Download app from Apple® store for iPhone® or Google® play for Andriod® (same as any other app download) then scan the QR code below to continue download (follow on-screen instructions).
- To install and transmit the data a WiFi connection is required.
- After downloading the App, a one-time security authentication is required by means of encrypted QR code. Verification can be performed by scanning the QR code below, before using the application.
- Ensure that only authorized personnel access to the QR Code the workshop receives.
- The following e-mail address is provided in the event UHD App support is required for the **Mercedes-Benz PartScan** App process: Mbdiagnosis@mbusa.com



Figure 1

i **Note:** Prior to replacing airbag, please check for SRS errors or messages in the instrument cluster:

- If an SRS error message is pending before start of work, **it must be documented and accounted for through the details outlined in Attachment A, page 13. Perform the recall repair accordingly.**

Procedure W/C 204

1. Disconnect ground line from the on-board electrical system battery.
2. Remove right A-pillar trim (**A**, figure 2).



Figure 2

3. Remove glove box housing

i For basic data of model 204, see **AR68.10-P-1200CW**

i Release inner retaining ring (**figure 3**) at the AUX connection towards the inside. The connection can then be removed from the glove box housing.

i Pull iPod cable **with** rubber grommet out of glove box housing until the connector plug makes contact with the housing. **Do not pull cable out of rubber grommet** because it is bonded to the rubber grommet and will otherwise be damaged!

i Pull out the iPod cable as far as possible and set down glove box housing on the windshield **with** exterior iPod cable connected (**figure 4**).



Figure 3



Figure 4

4. Remove air duct (B, figure 5) above the glove compartment.



Figure 5

5. Unclip and remove cover (C, figure 6) at the instrument panel on top.
i With a sound system, also remove speaker under the cover.



Figure 6





6. Remove center console (AR68.20-P-2000CW).
7. Remove automatic climate control and operating unit.
 -  For basic data of model 204, see **AR83.40-P-6350CW**
 -  For basic data of model 207, see **AR83.25-P1124EC.**
8. Remove trim (**D, figure 7**) around the instrument cluster.
 -  For basic data of model 204, see **AR54.30-P-6015CW.**
 -  For basic data of model 207, see **AR54.30-P-6015EZ.**



Figure 7

9. Remove the two bottom threaded connections (**E, figure 8**) of the instrument cluster.

i These screws are simultaneously fasteners for the instrument panel.

i The upper two screws do not need to be removed.



Figure 8

10. Remove four screws (**F, figure 9**) for fastening the instrument panel



Figure 9

11. Disconnect electrical contacts (**G**, figure 10) at the front passenger airbag.



Figure 10

12. Remove lock nuts (**H**, figure 11) for the front the passenger airbag.

i Lock nuts should only be replaced if they are damaged. For more info see:
AH00.00-N-0001-01A / Modification notes 27.10.2016



Figure 11

13. Slightly raise instrument panel at the front passenger side and remove the front passenger airbag in a downwards direction. Take special care not to crack the dashboard material.
DO NOT REMOVE THE DASHBOARD

14. Use the "Scan VIN" button (figure 12) to scan the vehicle identification number either by the barcode or the text field.

i After scanning, compare the vehicle identification number that has been read in the app and correct any scanning errors manually.

i All required data can also be read off and entered manually.

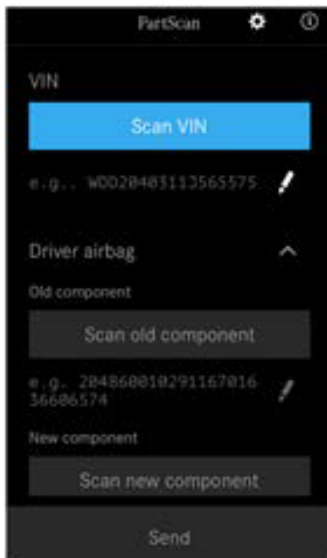

Figure 12

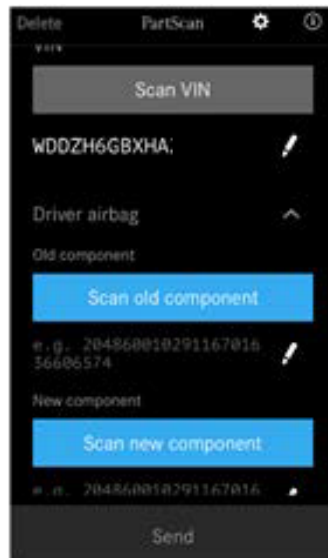

Figure 13



Figure 14

15. Scan barcodes of the removed passenger airbag using the button "Scan old component" (**figure 13**).

- i** Ensure that the lower barcode (**J, figure 14**) is scanned.
- i** This step can be omitted only if bar code is incomplete, illegible, or missing.
- i** All required data can also be read off and entered manually.

16. Scan the barcodes of the new passenger airbag using the button "Scan new component" (**figure 13**).

- i** Ensure that the lower barcode (**J, figure 14**) is scanned.
- i** All required data can also be read off and entered manually.

17. Create a scan ID via the "Send" button (**figure 15**).

- i** The generated scan ID (**figure 16**) must be recorded in writing in the workshop order and then stored in a tamper-proof manner.

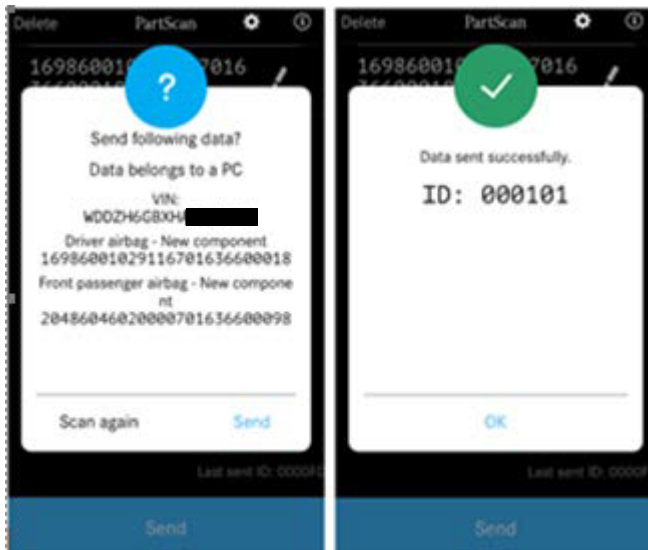

Figure 15

Figure 16

- i** For order invoicing, it is **mandatory** to enter the "ID" in the comment field of the **EVA / VEGA** application.

ID: _ _ _ _ _

18. Carefully insert the new front passenger airbag from below and fasten to the instrument panel with 4 nuts.

- i** Contrary to the work instructions in WIS, it is **not** necessary to check the supplemental restraint system with XENTRY/DAS following front passenger airbag replacement.
- Nm** Nut of front passenger airbag at instrument panel **5 Nm**.

19. Place instrument panel back into position and install the air ducts (**K, figure 17**) correctly.

- i** The air ducts are pulled out when the instrument panel is raised.



Figure 17

20. Assemble in reverse order.

21. Connect ground line to on-board electrical system battery.

22. Turn the transmitter key in the electronic ignition lock to **position 1** and check whether the airbag indicator lamp (**L, figure 18 or 19**) correctly switches off after a few seconds.

i The SRS check is thus completely ensured after airbag replacement.

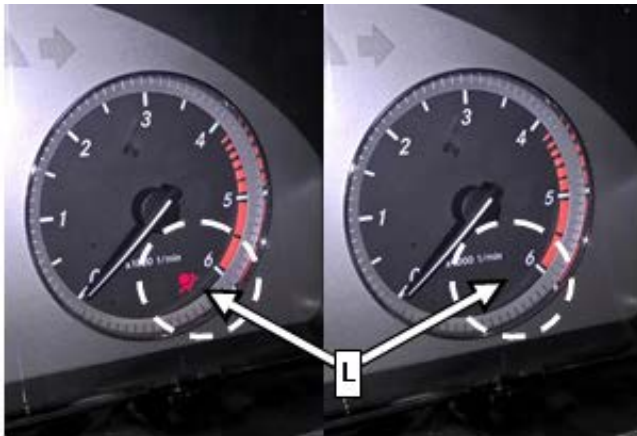

Figure 18



Figure 19

i **Note:**

- Requested parts must be returned in accordance with the warranty parts return requirements section found in the policy and procedures manual.
- Use the attached hazmat shipping document as a guide for shipping airbags.

i **Note** (regarding WIS documents referenced in this Procedure):

Replacement of parts not listed in the parts table of this Procedure are not claimable under this campaign. If replacement of additional part(s) is necessary, check coverage prior to submitting under warranty.

 **Special Tools**

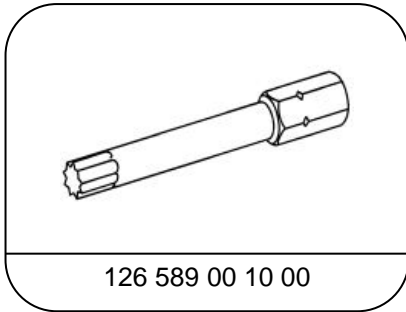

Screwdriver bit

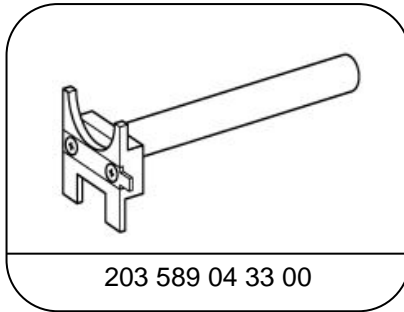

Removal lever

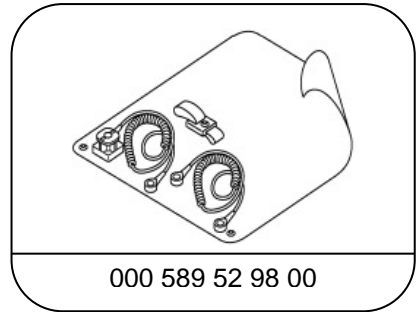

Electro Static Discharge (ESD) kit (or locally sourced equivalent)

Primary Parts Information

Qty.	Part Name	Part Number	Estimated Replacement Rate
As required	Front passenger airbag Type W204	A 204 860 12 00 05	100%
As required	Front passenger airbag Type C204 and 207	A 207 860 03 00 05	100%

 **Note:**

- Please be aware that only the part number(s) referenced in the Campaign Bulletin is/are approved for use to repair the vehicle. Repairs performed using any other part(s) will not have been performed in accordance with the campaign. Accordingly, warranty claims submitted with reference to an improper part number(s) will be denied.
- The following allowable labor operation should be used when submitting a warranty claim for this repair:

Warranty Information

Operation: Replace front passenger airbag (02-1415)

Damage Code	Operation Number	Labor Time (hrs.)
91 940 07 7	02-1415 (204)	1.4
	02-1415 (207)	1.6

(Includes: Disconnecting and connecting ground cable of on-board electrical system battery).

 **Note**

Operation Number labor times are subject to change.

Attachment A - SRS Light Diagnosis/Repair Process - Takata Airbag Recall Only

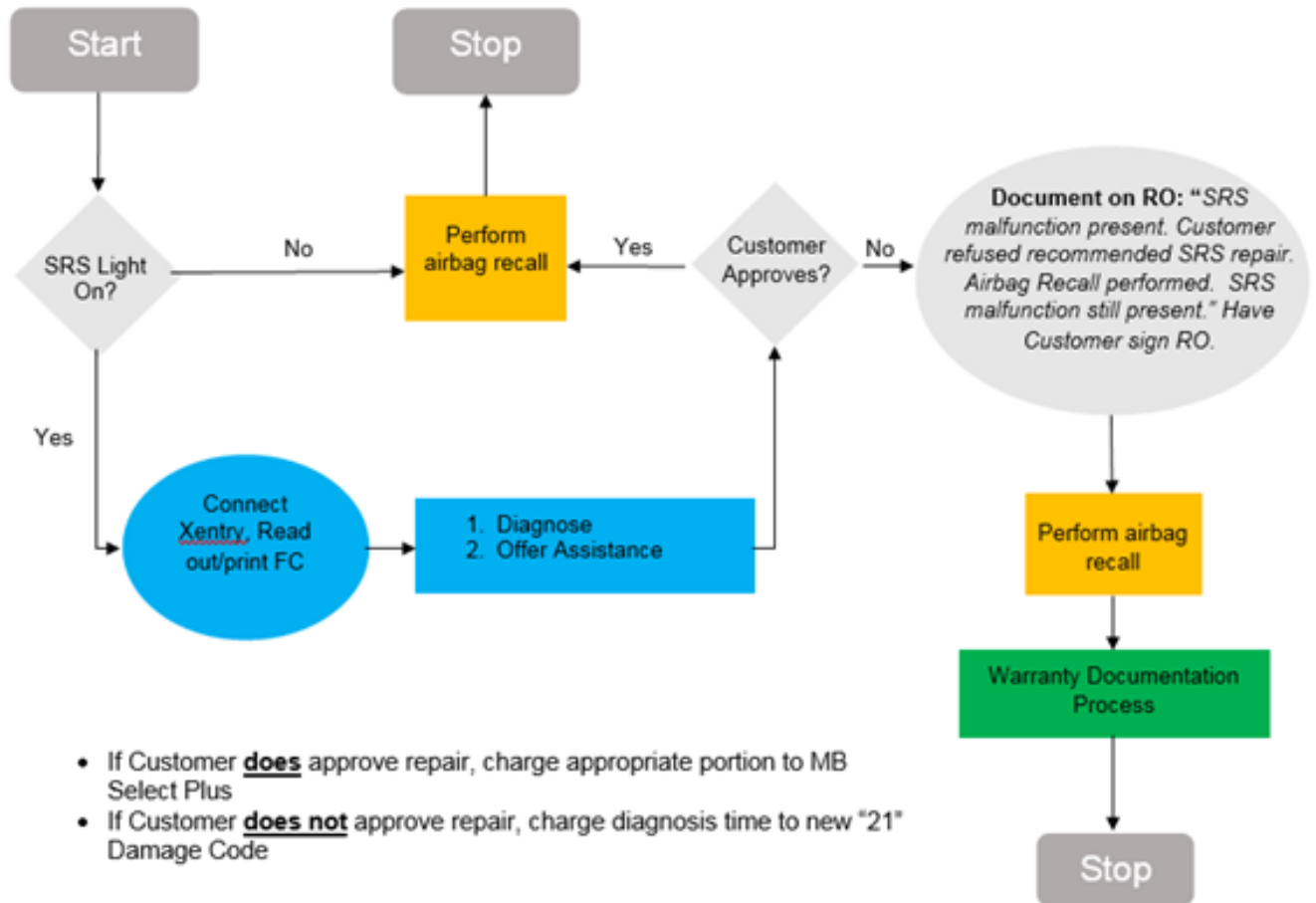

- If Customer **does** approve repair, charge appropriate portion to MB Select Plus
- If Customer **does not** approve repair, charge diagnosis time to new "21" Damage Code

Legend

- Claim against MB-Select Plus
- Claim against Recall
- Claim against new "21" damage code

Warranty Documentation Process

1. Claim against new "21" damage code
 - a) **21664 00 Takata Diagnosis – No Repair**
2. Up to 2 hours diagnostic time permitted
3. Ensure diagnostic time is properly punched on RO
4. Ensure RO is documented properly
5. Attach RO to warranty claim



Mercedes-Benz



Hazardous Materials Shipping Instructions - GROUND

Part Name: Airbag Part Numbers:	Hazardous Properties: Contains initiating component which deploys (inflates) airbag.
------------------------------------	---

STRAIGHT BILL OF LADING
ORIGINAL - NOT NEGOTIABLE

PIECES	IN	HM	DESCRIPTION	WEIGHT	RATE	CHARGES	CLASS
1 box		X	UN3268, Safety devices, 9	<i>Write gross weight of box here</i>			

This is to certify that the above-named materials are properly classified, described, packaged, marked and labeled, and are in proper condition for transportation according to the applicable regulations of the Department of Transportation.

SHIPPER HazMat Employee Signs	CARRIER Name of Carrier
EMERGENCY CONTACT: CHEMTREC 1-800-424-9300	

Steps to Return an Airbag:

REQUIRED PACKAGING:

- Carefully open received box and remove new airbag. Keep box intact & save all contents!
- Place used airbag into replacement airbag box, re-using any packaging material (e.g., cardboard inserts) used for the new airbag. Package as the new airbag was packaged.
- Use plastic adhesive tape 50 mm wide to secure the box closed. Do not obscure labels or text on the box with the tape.
- Ensure that the 4G fiberboard box is not ripped or damaged.

REQUIRED LABELS:

- A Class 9 Miscellaneous label must be clearly visible on one side of the box.

REQUIRED PACKAGE MARKINGS:

- The following words ("marking") must also be clearly visible on the same side of the box as the Class 9 label:
Safety devices
UN3268 (font size must be $\geq \frac{1}{2}$ inch)
- Affix "To/From" address label to same or adjacent packaging face as the hazardous markings/labels.
- The UN 4G code preprinted near the bottom edge of the box must also be clearly visible.

DOCUMENTATION:

- Include a HAZMAT bill of lading (see above example) with the package. For returns via DDS or FedEx Ground, the system will generate the Hazmat bill of lading.

COMMENTS:

- **Note:** The Packing Group and the EX# are no longer required to be printed on the HAZMAT bill of lading.
- **Package example:**



Questions? Contact MBUSA Corporate EH&S at (630) 462-3440 or (770) 705-2578

12/5/2016



Mercedes-Benz



Hazardous Materials Shipping Instructions for shipments using an Overpack - GROUND

Part Name: Airbag Part Numbers:	Hazardous Properties: Contains initiating component which deploys (inflates) airbags.
------------------------------------	--

STRAIGHT BILL OF LADING ORIGINAL - NOT NEGOTIABLE							
PIECE	IN	HM	DESCRIPTION	WEIGHT	RATE	CHARGES	CLASS
1 box		X	UN3268, Safety devices, 9 OVERPACK USED	Write gross weight of box here			

This is to certify that the above-named materials are properly classified, described, packaged, marked and labeled, and are in proper condition for transportation according to the applicable regulations of the Department of Transportation.

SHIPPER	HazMat Employee Signs	CARRIER	Name of Carrier
EMERGENCY CONTACT: CHEMTREC 1-800-424-9300			

Steps to Return Multiple Airbags in 1 Box:

REQUIRED PACKAGING:

- Carefully open received UN spec box and remove new airbag. Keep the box intact & save all contents!
- Place used airbag back into replacement airbag box, re-using any packaging material (e.g., cardboard inserts) used for the new airbag. Package as the new airbag was packaged.
- Use plastic adhesive packaging tape 50 mm wide to secure box closed. Do not obscure labels or text on box with tape.

REQUIRED LABELS:

- A Class 9 Miscellaneous label must be clearly visible on one side of the box.

REQUIRED PACKAGE MARKINGS:

- The following words ("markings") must also be clearly visible on the same side of the box as the label:
Safety devices
UN3268 (font size must be $\geq \frac{1}{2}$ inch)
- Affix "To/From" address label to same or adjacent packaging face as the hazardous markings/labels.
- The UN 4G code preprinted near the bottom edge of the box must also be clearly visible.

OVERPACKS (more than 1 airbag sent as 1 shipment):

- Package each airbag in a separate UN spec box prepared with the labels/markings described above.
- Place each individual airbag box inside a larger non-UN spec box to keep the shipment together.
- This larger box is called an "OVERPACK."

- The OVERPACK must have the identical markings and label as the boxes contained inside.
- The OVERPACK must have the "OVERPACK" statement on the same face as the hazard markings and labels. **Package example:**

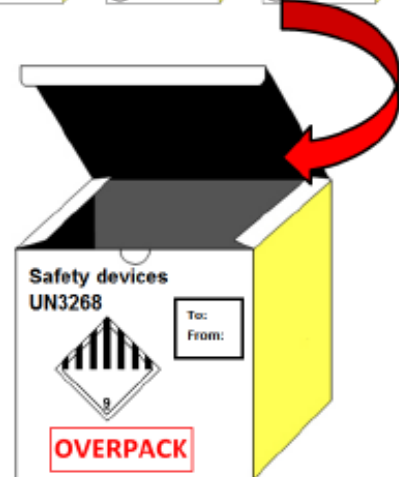
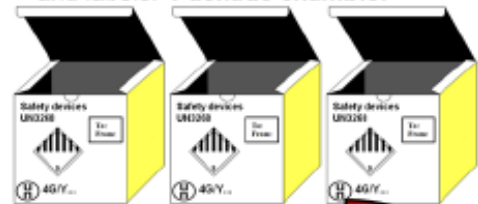

Questions? Contact MBUSA Corporate EH&S at (630) 462-3440 or (770) 705-2578

12/5/2016