

Product Safety Recall

15046 Front Passenger Air Bag Inflator



Release Date: November 2018

Revision: 00

Attention: General Motors has agreed to help facilitate the repair of the 2006 model year Saab 9-2X vehicles involved in this safety recall. All GM dealers are authorized to perform the required repair and submit for compensation through the Global Warranty Management (GWM) system. The parts needed to complete the repair are available directly from GMCCA via the normal parts ordering process. All involved vehicles are identified by Vehicle Identification Number (VIN) on the Investigate Vehicle History (IVH) screen in the GWM system.

This safety recall is included in the Takata Air Bag Completion Rate Improvement Program. This program is applicable to U.S. dealers only and includes a \$50.00 dealer completion bonus along with authorization for dealers to provide involved vehicle owners with courtesy transportation while their vehicle is being repaired. Refer to GM Service Information Bulletin #18-NA-094 for program guidelines.

It is a violation of Federal law for a dealer to deliver a new motor vehicle or any new or used item of motor vehicle equipment (including a tire) covered by this notification under a sale or lease until the defect or noncompliance is remedied.

All involved vehicles that are in dealer inventory must be held and not delivered to customers, dealer traded, or used for demonstration purposes until the repair contained in this bulletin has been performed on the vehicle.

Make	Model	Model Year		RPO	Description
		From	To		
Saab	9-2X	2006	2006		

Involved vehicles are marked "open" on the Investigate Vehicle History screen in GM Global Warranty Management system. This site should always be checked to confirm vehicle involvement prior to beginning any required inspections and/or repairs.

Condition	It has been determined that a defect, which relates to motor vehicle safety, exists in all 2006 model year Saab 9-2X vehicles that are not currently registered and, have never been registered, in Alabama, California, Florida, Georgia, Hawaii, Louisiana, Mississippi, South Carolina, Texas, Guam, Puerto Rico, Saipan, U.S. Samoa or U.S. Virgin Islands. In these vehicles, the front passenger air bag inflator module may experience an alteration over time, which could lead to overaggressive combustion in the event of an air bag deployment. This condition could create excessive internal pressure when the air bag is deployed, which could result in the body of the inflator rupturing upon deployment. In the event of an inflator rupture, metal fragments could pass through the air bag cushion material, which may result in injury or death to vehicle occupants.
Correction	Dealers are to replace the front passenger air bag module assembly.

Dealer Completion Bonus - U.S. Dealers Only

As part of the Takata Air Bag Completion Rate Improvement Program, dealers will be paid a \$50.00 bonus for the completion of the service procedure described in this bulletin. Refer to GM Service Information Bulletin #18-NA-094 for program guidelines.

Parts

Quantity	Part Name	Part No.
1	Front Passenger Air Bag Module Assembly	84651229

Parts required to complete this recall are to be obtained from General Motors Customer Care and Aftersales (GMCCA). **Order parts on a CSO only. All orders will be reviewed prior to being filled and DRO's may be cancelled. Parts may also have quantity limiters in effect.**

IMPORTANT: Due to limited initial parts availability, dealers are encouraged not to order parts for use as shelf stock.

If stock is not located at your Administrative PDC, due to flight restrictions for hazardous goods shipments, dealer orders may arrive via FedEx or with your normal PDC delivery. **Do not place orders as an OVN or SPAC case; as it will delay shipment of the part and will not provide visibility for order tracking.** Parts will not be shipped overnight, so plan accordingly for transit time to reach your facility.

IMPORTANT: All front passenger air bag inflators replaced in accordance with this recall must be returned to TK Holdings, Incorporated. Under no circumstances should any replaced air bag inflator be returned to GM, ORIO or Subaru of

Product Safety Recall

15046 Front Passenger Air Bag Inflator



America. Refer to the return shipping instructions provided at the end of this bulletin. **Do not discard or destroy the box containing the new air bag inflator, it will be needed to return the old air bag inflator.**

Courtesy Transportation - U.S. Dealers Only

As part of the Takata Air Bag Completion Rate Improvement Program, dealers are authorized to provide alternate transportation to affected vehicle owners while their vehicle is at a GM dealership for completion of the service procedure described in this bulletin. Refer to GM Service Information Bulletin #18-NA-094 for program guidelines.

Warranty Information

Labor Operation	Description	Labor Time	Trans. Type	Net Item
9104209	Replace Front Passenger Air Bag Module Assembly	1.1	ZFAT	* ** ***
9104210	Cost of Scan Tool (Only 1 Tool Per Dealer Allowed)	N/A	ZFAT	****

- * Submit a \$20.00 administrative allowance for return of the old front passenger air bag module assembly (includes document preparation and packaging). Add this amount in the Administrative Allowance Net Item Field when submitting the repair transaction.
- ** **U.S. Dealers Only:** As part of the Takata Air Bag Completion Rate Improvement Program, dealers are eligible for a \$50.00 completion bonus for each repair performed. Add this amount in the Miscellaneous Net Item Field when submitting the repair transaction. Refer to GM Service Information Bulletin #18-NA-094 for program guidelines.
- *** **U.S. Dealers Only:** As part of the Takata Air Bag Completion Rate Improvement Program, involved vehicle owners are eligible for courtesy transportation while their vehicle is being repaired. If courtesy transportation is required, add the actual cost in the Courtesy Transportation Net Item Field when submitting the repair transaction. Refer to GM Service Information Bulletin #18-NA-094 for program guidelines.
- **** Submit the actual cost of the scan tool, not to exceed \$200.00 USD.

Part Return Instructions

All front passenger air bag module assemblies replaced in accordance with this recall must be returned to TK Holdings, Incorporated. Do not discard or destroy the box containing the new air bag module assembly, it will be needed to return the old air bag module assembly. The box also contains forms and labels for the return of the old air bag module assembly. **Except for the return address label, discard all other documents in the box as they have been superseded and are no longer applicable. Instead, follow the “Appendix A” provided at the end of this bulletin.** These instructions were originally intended for Saab Official Service Centers (OSCs), but have been approved for all GM dealers except Canada. **GM dealers located in Canada must follow the “Canada Only - Used Air Bag Return Process” provided at the end of this bulletin.**

WARNING: Do not deploy any front passenger air bag inflator prior to shipment. Doing so could result in severe injury to the technician or other people in the area.

NOTE: When affixing return shipping labels to the box do not obstruct the bar code label. A copy of the job card must also be included in the box with the returned air bag inflator. The job card number, repair date, repair mileage and full 17-character VIN must be clearly visible on the job card.

Product Safety Recall

15046 Front Passenger Air Bag Inflator



Special Tools



(1) Trim Clip Removal Tool * (2) Autel MD802 Maxidiag Elite Scan Tool ** (3) Autel MD808 Maxidiag Elite Scan Tool **

This trim clip removal tool (1) must be used to properly perform the front passenger air bag module replacement procedure described in this bulletin. GM dealers should already have at least one of these trim clip removal tools in their special tool inventory.

This scan tool (2) or (3) must be used to properly perform the front passenger air bag module replacement procedure described in this bulletin. Dealers should purchase this scan tool either online or locally. **GM will reimburse for only one scan tool per dealer.** Tool description: Autel MD802 or MD808 Maxidiag Elite Scan Tool with all systems diagnoses, OBDII full functions and reset services.

Service Procedure

NOTE: This recall bulletin provides service repair and labor time information for replacing the front passenger side air bag assembly only. Other repairs, if required, are to be billed under warranty, goodwill assistance or customer pay.

IMPORTANT: The new front passenger air bag assembly does not include the outer trim cover/lid. In this procedure, the cover/lid is transferred to the new air bag assembly from the original.

Turn the ignition to the “ON” position.

- Connect the VDI or equivalent scan tool (such as the Autel MD802 Maxidiag Elite or MD808 Maxidiag) to the DLC and determine if any diagnostic trouble codes (DTCs) have been set.
- Scan tool diagnostic path:
 - Select “Scan” from the main screen
 - Select “Asia”
 - Select “Subaru”
 - Select “Control Unit”
 - Select “Airbag System”
 - Select “OK” to confirm your selection
 - Select “Read Codes” to read DTC’s.
- Record set DTCs, if present, on the Repair Order. Notify the owner of condition, cause and correction recommendation and secure the owners authorization to proceed with any non-recall related repairs prior to continuing with the recall procedures.
- Once the fault has been repaired, follow step 3 again and instead of selecting “Read Codes”, select “Erase Codes”.

Product Safety Recall

15046 Front Passenger Air Bag Inflator



- Turn the ignition "OFF".
- Disconnect the Negative (ground) cable from the battery and wait at least 90 seconds before proceeding further.

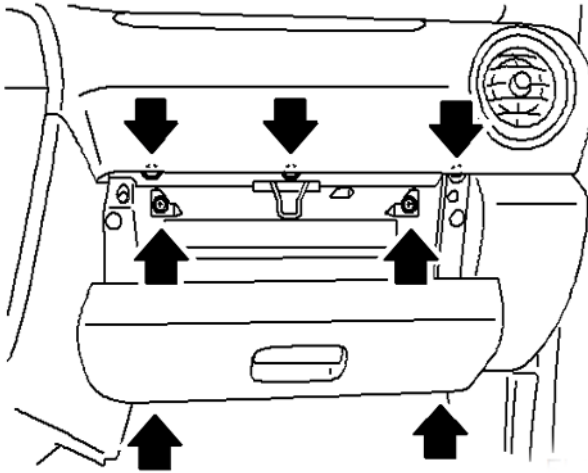

5145835

- Remove the glove box assembly. The glove box is held in place by 7 screws.

WARNING: Whenever beginning to remove (or install) the airbag assembly, and periodically while performing the procedure or after stepping away, remove any possible static charge from your body by momentarily touching a clean, bare metal ground point on the vehicle (e.g. the door striker). Remove from your person all electronic devices including cell phones before proceeding.

- Disconnect the airbag module harness connector (A) and release it from the support beam bracket.

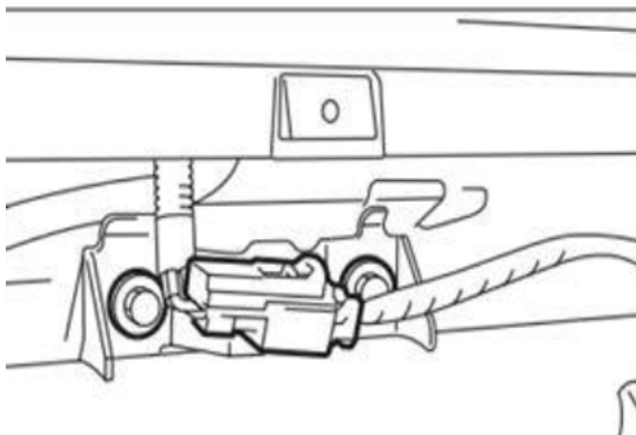

5145837

- Remove the 3 retaining bolts and CAREFULLY remove the airbag module from the vehicle and place it on a clean cloth to protect the dash trim outer surface portion from damage.

NOTE: There may be a Security Module secured with the lower airbag module mounting bolt on some models.

Product Safety Recall

15046 Front Passenger Air Bag Inflator

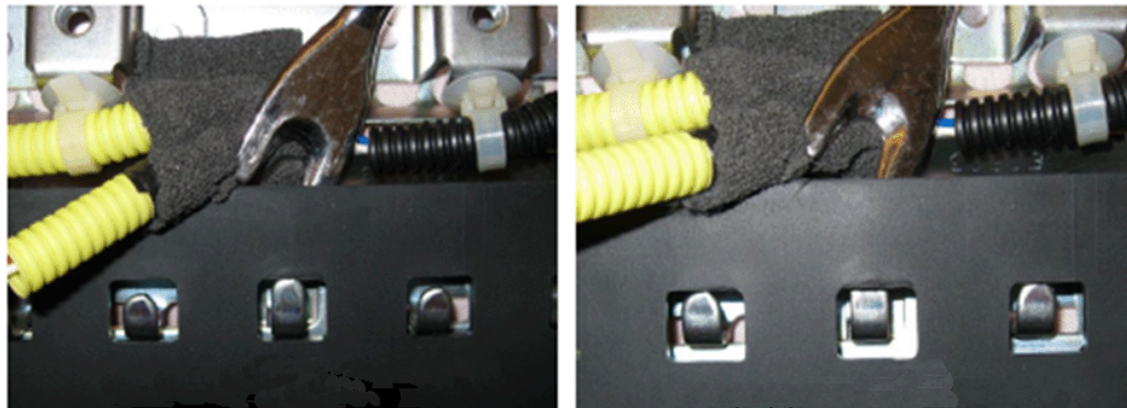
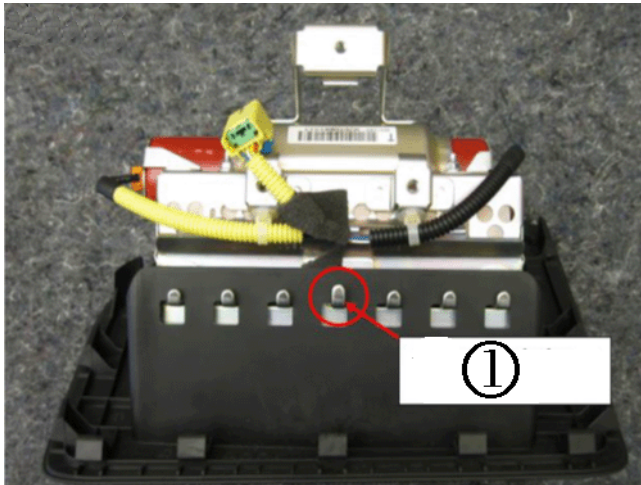

- Using a trim clip removal tool and starting on the harness-side of the module assembly as shown and sequence below, **CAREFULLY** insert the tool and twist **ONLY AS MUCH AS IS REQUIRED** to release the slightly longer center retaining claw from the trim cover. Once released with the tool, the other 6 claws will release easily by hand.

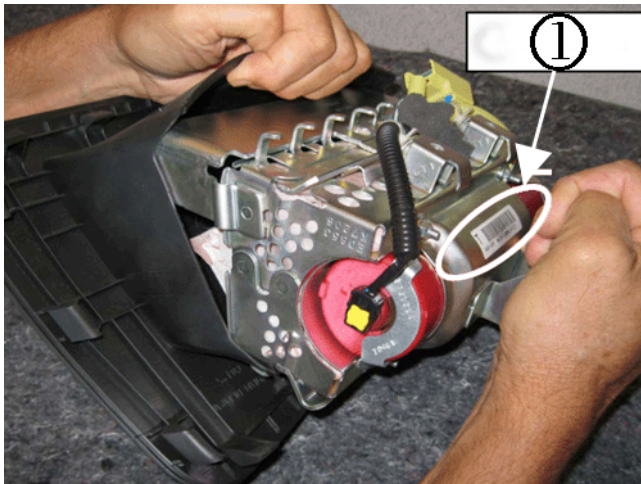

- Rotate the inflator portion of the assembly outward from the cover to release the 7 label-side (1) claws and separate the cover from the module. No tool is required as all the 7 label-side claws are the same size.

Product Safety Recall

15046 Front Passenger Air Bag Inflator

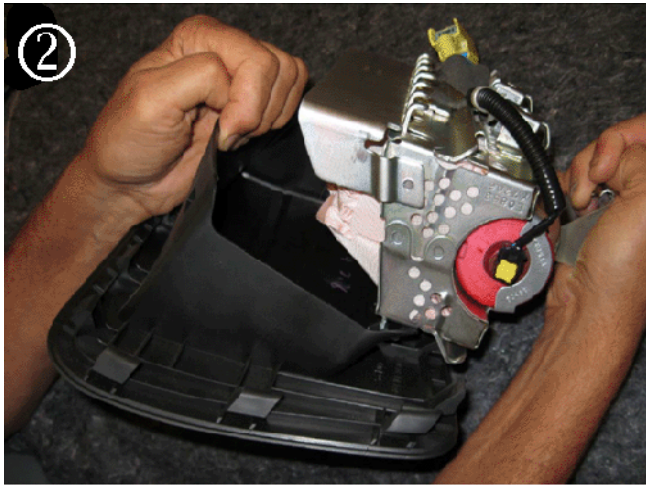

5145904



5145907

- Once all the harness-side retaining claws are released (easily done once the center claw is released), CAREFULLY separate the inflator module from the cover. After the harness-side of the module is free from the cover (2), simply rotate it to unhook the label-side retaining claws. Remove the cover completely as shown (3).

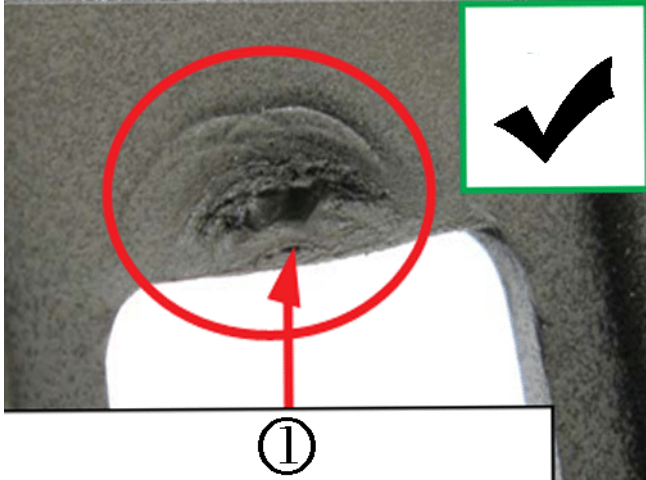

5145908

Product Safety Recall

15046 Front Passenger Air Bag Inflator

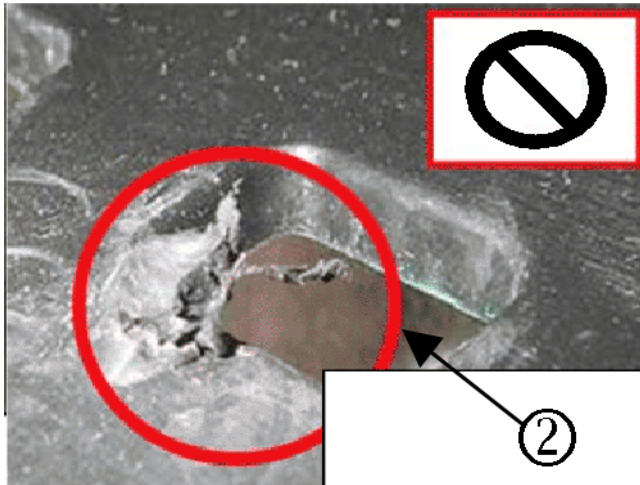

5145910

- Inspect the claw openings on the outside and inside of the cover for damage. If any found to look like the (2) the cover must be replaced.

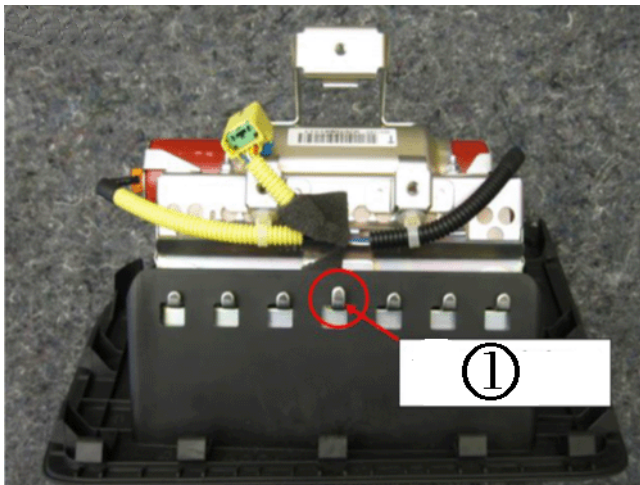

5145881

- Refit the cover onto the replacement module assembly, making sure all the claws are fully engaged (picture above). For this application, the cover will only fit on the module one way. When properly installed, the cover should feel loose with a small amount of free play. If the cover is tight (no free play or looseness), it most likely is not fully engaged onto the claws.
- **VERY IMPORTANT:** Record the alpha-numeric serial numbers for BOTH the original and the replacement module assemblies on the hard copy of the Repair Order.
- Place the removed module assembly into the returnable shipping box. Refer to the **SHIPPING DOCUMENTATION AND INSTRUCTIONS: (Appendix A) found toward the end of this bulletin.**

Product Safety Recall

15046 Front Passenger Air Bag Inflator



5145913

- After confirming the cover is properly fitted to the module, reinstall the module assembly. The retaining tabs around the perimeter of the cover must also be fully seated so it sits flush with the surrounding dash pad surface. Carefully place the airbag module through the top of the dash. Push down to install.

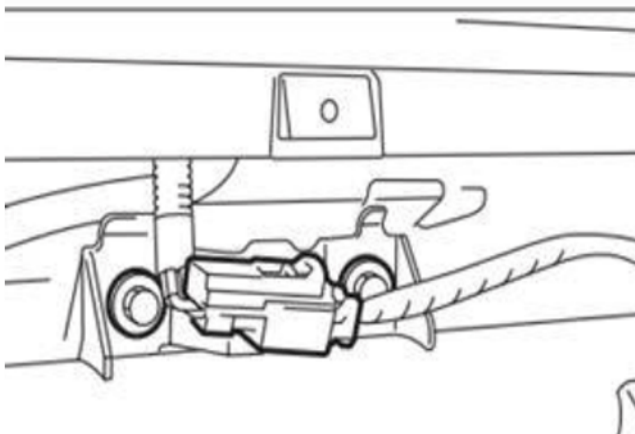

5145837

- Install the 3 retaining bolts from the bottom and torque to 7 Nm (62 lb in).
NOTE: If a Security Module is installed to one of the air bag assembly mounting bolts, torque that specific bolt to 10 Nm (88 lb in) +/-Nm rather than the normal 7 Nm (62 lb in).
- Before installing the glove box assembly, reconnect the negative battery cable. Turn the ignition key "ON" and confirm the AIRBAG warning light comes on then cycles off properly. Once proper warning light operation is confirmed, reinstall the glove box assembly to complete the procedure.

Product Safety Recall

15046 Front Passenger Air Bag Inflator

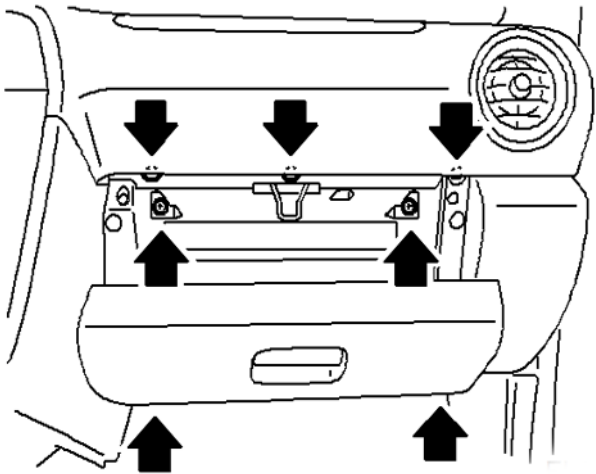

5145835

- Install the glove box assembly. Insure the glove box closes correctly.
- Verify no DTC's have been set.

WARNING: Do not deploy any front passenger air bag module assembly prior to shipment. Doing so could result in severe injury to the technician or other people in the area.

IMPORTANT: All front passenger air bag module assemblies replaced in accordance with this recall must be returned to TK Holdings, Incorporated. Under no circumstances should any replaced air bag module assembly be returned to GM, ORIO or Subaru of America. Refer to the return shipping instructions provided in this bulletin.

NOTE: When affixing return shipping labels to the box do not obstruct the bar code label. A copy of the job card must also be included in the box with the returned air bag inflator. The job card number, repair date, repair mileage and full 17-character VIN must be clearly visible on the job card.

Dealer Responsibility – U.S. States, Territories, and Possessions

It is a violation of Federal law for a dealer to deliver a new motor vehicle or any new or used item of motor vehicle equipment (including a tire) covered by this notification under a sale or lease until the defect or noncompliance is remedied.

The U.S. National Traffic and Motor Vehicle Safety Act provides that each vehicle that is subject to a recall of this type must be adequately repaired within a reasonable time after the customer has tendered it for repair. A failure to repair within sixty days after tender of a vehicle is prima facie evidence of failure to repair within a reasonable time. If the condition is not adequately repaired within a reasonable time, the customer may be entitled to an identical or reasonably equivalent vehicle at no charge or to a refund of the purchase price less a reasonable allowance for depreciation. To avoid having to provide these burdensome remedies, every effort must be made to promptly schedule an appointment with each customer and to repair their vehicle as soon as possible. In the recall notification letters, customers are told how to contact the U.S. National Highway Traffic Safety Administration if the recall is not completed within a reasonable time.

All new, used, GM Certified Used, courtesy transportation vehicles, dealer shuttle vehicles, etc. in dealers' possession and subject to this recall must be held and inspected/repared per the service procedure of this bulletin before customers take possession of these vehicles. Involved vehicles must be held and not delivered to customers, dealer-traded, released to auction, used for demonstration, or any other purpose.

All GM Certified Used vehicles currently in the dealers' inventory within the Certified Pre-Owned Inventory System (CPOIS) will be de-certified and must be held and remedied per the service procedure in this bulletin. Upon submitting an accepted/paid warranty transaction in the Global Warranty Management (GWM) system, the vehicle can be re-certified for sale within the CPOIS system, or once again be used in the CTP program.

Dealers are to service all vehicles subject to this recall at no charge to customers, regardless of mileage, age of vehicle, or ownership, from this time forward.

Customers who have recently purchased vehicles sold from your vehicle inventory, and for which there is no customer information indicated on the dealer listing, are to be contacted by the dealer. Arrangements are to be made to make the required correction according to the instructions contained in this bulletin. Recall follow-up cards should not be used for this purpose, since the customer may not as yet have received the notification letter.

Product Safety Recall

15046 Front Passenger Air Bag Inflator



In summary, whenever a vehicle subject to this recall enters your vehicle inventory, or is in your dealership for service in the future, you must take the steps necessary to be sure the recall correction has been made before selling or releasing the vehicle.

Dealer Reports

For dealers with involved vehicles, a listing with involved vehicles has been prepared and will be provided to U.S. dealers through the GM GlobalConnect Recall Reports. The listing may contain customer names and addresses obtained from motor vehicle registration records. The use of such data for any purpose other than follow-up necessary to complete this recall is a violation of law in several U.S. states/territories/possessions. Accordingly, you are urged to limit the use of this report to the follow-up necessary to complete this recall.

Customer Notification

General Motors will notify customers by letter of this recall on their vehicle.

GM bulletins are intended for use by professional technicians, NOT a "do-it-yourselfer". They are written to inform these technicians of conditions that may occur on some vehicles, or to provide information that could assist in the proper service of a vehicle. Properly trained technicians have the tools, equipment, safety instructions, and know-how to do a job properly and safely. If a condition is described, DO NOT assume that the bulletin applies to your vehicle, or that your vehicle will have that condition. See your dealer for information on whether your vehicle may benefit from the information.



**We Support
Voluntary Technician
Certification**

Product Safety Recall

15046 Front Passenger Air Bag Inflator



SHIPPING DOCUMENTATION AND INSTRUCTIONS: (APPENDIX A)

FULL MODULE RETURNS

These Return Instructions are for the Continental US dealerships (48 States).

NOTE: Locations outside of the Continental United States (Hawaii, Alaska, Puerto Rico, Virgin Islands INCLUDING Mexico and Canada CANNOT follow below shipping instructions. Instead, dealerships in these locations MUST contact the following Takata/XPO USA representative directly for shipping instructions: Miguel Prigadaa – Tel #: 210-250-5078 or Email: MLGTakataRestrains_International@menlowworldwide.com

1. Shipping Documents

a) Box Label

- Supplied with each Kit
- To be affixed to each box



b) Over-pack Label

- To be supplied by XPO.
- To be affixed to the outside of each pallet



c) Bill of Lading

- To be supplied by XPO.
- Print 2 copies: 1 for Dealer Records, 1 for LTL Driver



d) ERG Document

- To be supplied by XPO.
- To be provide by the Saab OSC to the LTL Driver for each shipment



5. Shipping Instructions – Prepare the Pallet

a) Accumulate and palletize Kits

b) Arrange Kits on Pallet as pictured here

- 15 boxes per row/layer (5x3)
- 5 rows/layers per pallet (75 boxes)



c) Shrink-wrap Kits to Pallet

d) Affix Over-pack Label on (1) side of Pallet (Not on Top)

6. Shipping Instructions – Schedule LTL Pickup

a) Upon Accumulating 75 kits (1 Over-pack/Pallet) Minimum

- Call XPO at 1-877-650-3476
- If 75 Kits have not been accumulated in 30 days, please call XPO for direction

c) Have the following Information Available

- Saab OSC #
- Quantity of Over-packs/Pallets
- Quantity of Passenger Inflator Kits on each Pallet
- Email Address where shipping Documentation can be received

2. Packing Instructions

a) Confirm box is in acceptable condition. If a new box is needed, follow the New Box instructions located **In Box 8 of this page.**

b) Place the un-deployed air bag module in the “cradle” of the box insert.



7. Shipping Instructions – Ship

a) Give 1 Copy of BOL and 1 Copy of ERG to Driver

b) Retain 1 Copy of BOL for Saab OSC records and archive for 2 Years

3. Closure Instructions

a) Close the top box flap, per box closure instructions located on front panel of box.



8. Requesting a New Box / Shipping Labels

If a new box or replacement shipping labels are needed, please contact the representative listed below by phone or email to request replacement materials.

Primary Contact: **Armando Gonzalez - Tel #: 210-250-5079**
E-Mail: FieldAction.14305@menlowworldwide.com

To help expedite your request, please be prepared to provide the following information:

a) Serial number on the original box

b) What Type of shipping material needed

- Replacement Box
- Two Part Return Label
- Bill of Lading
- ERG Form

c) Dealer Shipping Information

- Contact name
- Saab OSC Address
- Phone Number



4. Shipping Instructions - Label each Box

a) New Labels will begin shipping in each kit starting mid August, 2015

- Subaru Module Kit will contain this two-part label:
- Peel off "Ship To" label.
- Affix Label to Box. Do not cover up Class 9 marking.

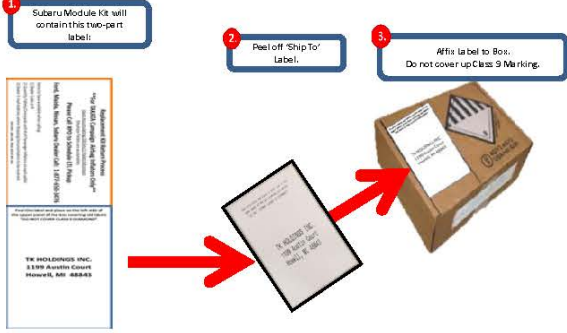

Product Safety Recall

15046 Front Passenger Air Bag Inflator



Canada Only - "Used Airbag Return Process - for Recalls Only"

The following instructions is the return process for used airbag as identified in Recall Bulletins.
IMPORTANT: Do not deploy any airbag. The person packing the used airbag module must read & follow the instructions below.

Shipping/Handling Instructions: On top of the Box CLEARLY WRITE (Large Print):

"USED AIRBAG - RECALL # (IDENTIFY RECALL NUMBER)"

Insert a completed copy of the R.O. The following information about the vehicle being serviced with the replacement inflator must be documented and returned with the suspect inflator removed from the vehicle.

VIN (17 Characters):

Vehicle Make, Model and Model Year:

Odometer reading:

Dealership Postal Code:

Canadian Dealers: Airbag returns are to be processed through your normal return process. No return tag/credit will be issued for used airbags. Refer to Recall Bulletins for applicable returns required.

- Complete a PC0302C (302C) form and ensure that the TDG section is completed correctly.
- At time of returns pickup, provide driver with the 302C form with the used airbag(s) properly manifested, for shipment back to your PDC.
(Driver will not pick up any product without this document filled out and signed.)

PDC contact and fax numbers for YOUR Servicing PDCs:

- Woodstock Service Dealers (519) 536-7410 Fax: (519) 536-7409
- Edmonton Service Dealers (780) 451-7019 Fax: 1-866-350-6233
- Montreal Service Dealers (514) 630-6162 Fax: (514) 630-7362
- Vancouver Service Dealers (604) 857-4347 Fax: (604) 857-4402

« Processus de retour des sacs gonflables usagés – Rappels seulement »

Uniquement au Canada

Les renseignements suivants concernent le processus de retour des sacs gonflables usagés, comme indiqué dans les bulletins de rappel. **IMPORTANT : Ne pas déployer le sac gonflable. La personne qui emballe le module de sac gonflable usagé doit lire et suivre les instructions ci-dessous.**

Directives relatives à l'expédition et la manutention : Sur le dessus de la boîte, INSCRIVEZ LISIBLEMENT (en gros caractères) :

« SAC GONFLABLE USAGÉ – RAPPEL N° (INDIQUEZ LE NUMÉRO DE RAPPEL) »

Insérer une copie dûment remplie du bon de réparation. Les renseignements suivants sur le véhicule dans lequel sera installé le dispositif de gonflage neuf doivent être fournis et retournés avec le dispositif de gonflage suspect retiré du véhicule.

NIV (17 caractères) :

Marque, modèle et année modèle du véhicule :

Kilométrage:

Code postal du concessionnaire :

Concessionnaires canadiens : Les retours de sac gonflable doivent être effectués selon votre procédure de retour normale. Aucune étiquette de retour/de crédit ne sera émise pour les sacs gonflables usagés. Reportez-vous aux bulletins de rappel pour les retours applicables requis.

Remplissez le formulaire PC0302C (302C) et assurez-vous que la section TMD est remplie correctement.

- Au moment du ramassage, donnez le formulaire 302C au conducteur avec les sacs gonflables usagés correctement étiquetés pour qu'ils soient retournés à votre CDP.
(Le conducteur ne ramassera pas de produit sans ce document rempli et signé.)

Numéros de téléphone et de télécopieur des CDP :

- Concessionnaires desservis par le CDP de Woodstock : 519 536-7410 Télécopieur : 519 536-7409
- Concessionnaires desservis par le CDP d'Edmonton : 780 451-7019 Télécopieur : 1 866 350-6233
- Concessionnaires desservis par le CDP de Montréal : 514 630-6162 Télécopieur : 514 630-7362
- Concessionnaires desservis par le CDP de Vancouver : 604 857-4347 Télécopieur : 604 857-4402