

Customer Service Notice

Date: March 13, 2017

Units Affected: TA37M, TA41M, and TA45M units built between January 2005 and April 2016 (see attached list)

Winch Brake Inspection

Altec is committed to providing our customers with safe and reliable products from initial delivery throughout the useful life of the machine.

Altec has discovered that some winch brakes on the material handling winches used on the affected units may have been installed incorrectly. An incorrectly installed winch brake may not hold a stationary load resulting in uncommanded motion of the load if the unit experiences a hydraulic line failure. **Death or serious injury can result from uncommanded motion of the winch line load.**

Altec requires that two actions be done on the affected units no later than 90 days from the receipt of this CSN.

- The material handling winch brake be inspected for the correct installation.
- A brake torque adjustment be performed.

The inspection and adjustment procedure begins on Page 2. A brake torque adapter kit (p/n 990387377) is required for the inspection and adjustment (refer to Figure 1). Call 1-877-GO ALTEC (1-877-462-5832) to order the kit.

This repair is covered under the Altec Warranty Policy and can be performed by Altec, the customer, or the customer's warranty provider. Altec will allow up to \$180 for the labor to perform this repair. A warranty claim must be submitted to be reimbursed for the cost of the parts and/or labor. Call 1-877-GO ALTEC (1-877-462-5832) to schedule the work to be done by an Altec service technician. Customers are responsible for the travel costs of an Altec Mobile Service technician if the technician performs the inspection or repair at the owner's location.

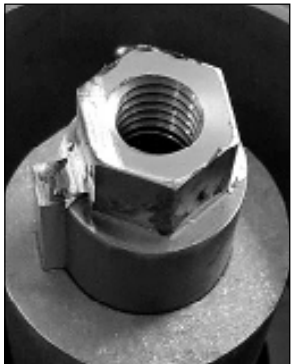

Figure 1 — Brake Torque Adapter (shown in motor shaft)

Material Handling Brake Inspection and Adjustment Procedure

Normal mechanic's hand tools, an accurately calibrated, click-type torque wrench, and a brake torque adapter are required for the inspection and any corrections needed. SAE 85W-140 gearbox oil (p/n 970182880) may be required on some units if oil is lost through the procedure. Read and understand all steps of the instructions before beginning the procedure.

1. Position the unit on a level surface, apply the parking brake and chock the wheels. Engage the unit's hydraulic system. Properly set the outriggers.
2. Operate the unit to position the platform and winch so that it can be reached from the ground. Rotate the jib so the jib tip is toward the ground putting the winch brake pointing up and the winch motor towards the ground. Disengage the unit's hydraulic system.



Death or serious injury can result from hydraulic oil being injected into the flesh when loosening or disconnecting hydraulic components. Remove the pressure before loosening or disconnecting hydraulic components.

Seek medical attention if injured by escaping hydraulic oil. Serious infection or reaction can result if medical treatment is not given immediately.

Spilled hydraulic oil creates slick surfaces and can cause personnel to slip and/or fall. Keep the unit and work areas clean.

3. Release any pressure in the hoses connected to the winch motor by moving the winch control on the upper controls to the Raise and Lower positions several times.
4. Remove the winch covers to allow access to the winch and hydraulic winch motor. Look for the serial number placard on the winch. If the serial number starts with a 0 or 1, continue to the Tulsa Winch section beginning with Step 5. If the serial number starts with 53471 or 6096, continue to the Altec or Ramsey winch section beginning with Step 19.

Tulsa Winch Instructions

5. Place a container under the hoses connected to the winch to catch the hydraulic oil. Mark the hose connections and disconnect the hoses from the winch motor. Cap the ports in the motor and plug the hoses.
6. Remove the two cap screws that attach the hydraulic motor to the winch gearbox. Remove the hydraulic motor from the input of the winch.
7. Insert the brake torque adapter into the coupling on the winch input shaft.
8. Use a $\frac{3}{4}$ " socket on the torque wrench to attach the brake torque adapter. Turn the adapter clockwise facing the brake housing (or counterclockwise facing the end of the input shaft). If the brake engages when rotating the input shaft, go to Step 17. If the brake does not engage, continue on to Step 9.

9. Remove the set screw and lock nut from the winch brake cover (refer to Figure 2).

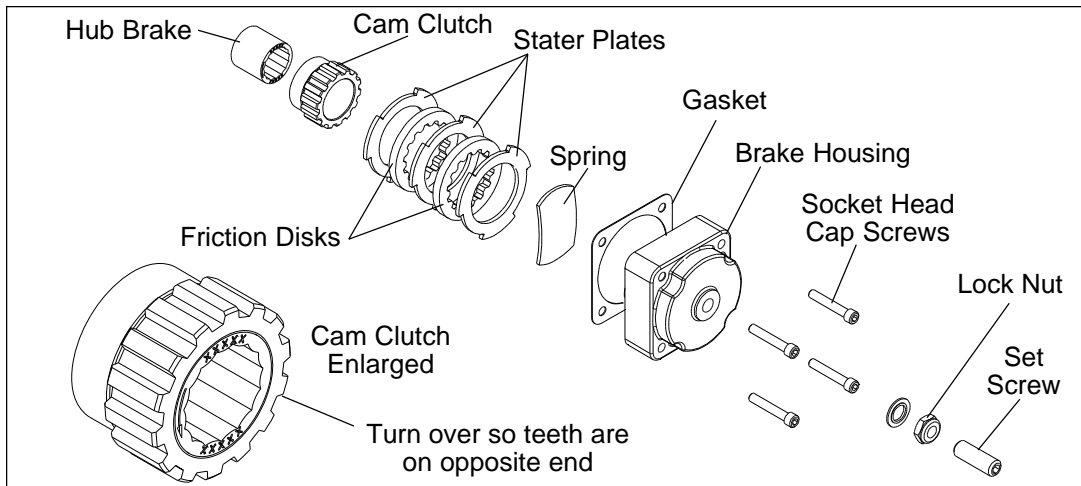

Figure 2 — Tulsa Winch Parts

10. Remove the four socket head cap screws.
11. Carefully remove the brake housing, spring, stator plates, and the friction disks so the gasket is not damaged.
12. Remove the hub brake and cam clutch. Turn the clutch over and reinstall it so it is positioned with the opposite side out from the original assembly. Reinstall the hub brake and cam clutch. Reinstall the stator plates, friction disks, and the spring.
13. Install the cover and tighten the four socket head cap screws to 7 ft-lbs.
14. Install the set screw and lock nut in the end of the cover so that the set screw is hand tight.
15. Make sure the drain plug is in place and add SAE 85W-140 gear oil to replace any oil that was lost.
16. Use the torque adapter to turn winch in the Winch Raise direction at least one turn of the input shaft.
17. Set the torque wrench to 13-15ft.-lbs. Insert the brake torque adapter into the coupling on the input shaft and attach the torque wrench. Rotate the winch input shaft clockwise when facing the brake end (counterclockwise facing the input shaft end). Tighten the adjusting screw on the winch brake by turning it about $\frac{1}{8}$ of a turn or less, while continuously checking the torque until the brake holds when 13-15 ft.-lbs. of torque is applied to the input shaft. **CAUTION:** Do not over tighten. This can damage the brake parts and cause overheating. If the specified torque cannot be reached while tightening the adjustment screw, the friction disks may need to be replaced. **NOTE:** The friction disk will receive the same amount of wear regardless of the clutch orientation. Any excessive wear of the friction disk comes from use over time and is not a result of improper clutch installation.

18. Tighten the lock nut and check the torque again to be sure it did not change when the adjustment nut was tightened. Readjust as needed. Check the torque at least four times to make sure the adjustment is correct before continuing to Step 38.

Altec or Ramsey Winch Instructions

19. Place a container under the hoses connected to the winch to catch the hydraulic oil. Mark the hose connections and disconnect the hoses from the winch motor. Cap the ports in the motor and plug the hoses.

20. Remove the two cap screws that attach the hydraulic motor to the winch gearbox. Remove the hydraulic motor from the input of the winch.

21. Insert the brake torque adapter into the coupling on the input shaft.

22. Use a 3/4" socket on the torque wrench to attach the brake torque adapter. Turn the adapter clockwise facing the brake housing (or counterclockwise facing the end of the input shaft). If the brake engages when rotating the input shaft, go to Step 36. If the brake does not engage, continue on to Step 23.

23. Loosen the winch brake lock nut and loosen the winch brake adjusting screw at least two turns to remove the tension from the brake. Do not remove the adjusting screw from the winch cover.

24. Remove the four brake cover mounting screws.

25. Carefully remove the cover so the cover gasket is not damaged.

26. Remove the coil spring and two leaf springs from the brake assembly (refer to Figure 3).

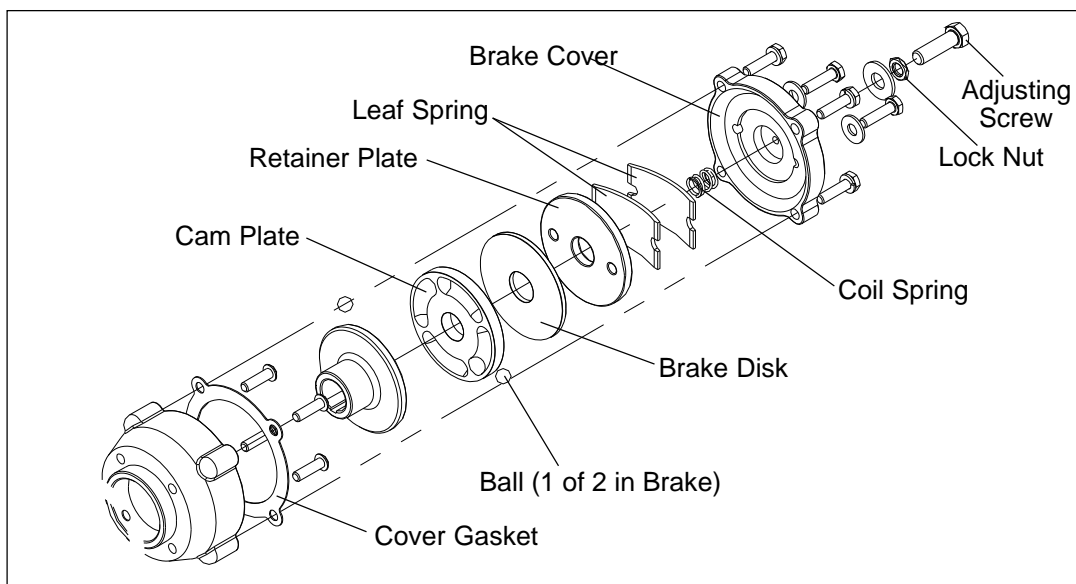

Figure 3 — Altec or Ramsey Winch Parts

27. Remove the retainer plate and composition brake disk. Remove the cam plate noting the original installation location in relation to the balls and slots. NOTE: It may be useful to use two flat head screwdrivers to remove these components. Take care not to damage the parts.
28. **Ramsey Winch:** rotate the cam plate so the slot with the 1 next to it (refer to Figure 4) lines up with the balls and slots in the hub and reinstall it.

Altec Winch: rotate the cam plate 90 degrees from its original position and reinstall it. If unable to determine which way the cam plate was installed originally, look at the amount of wear in the four slots (refer to Figure 4). The cam plate should be positioned so that the two slots without wear line up with the balls and slots in the hub.

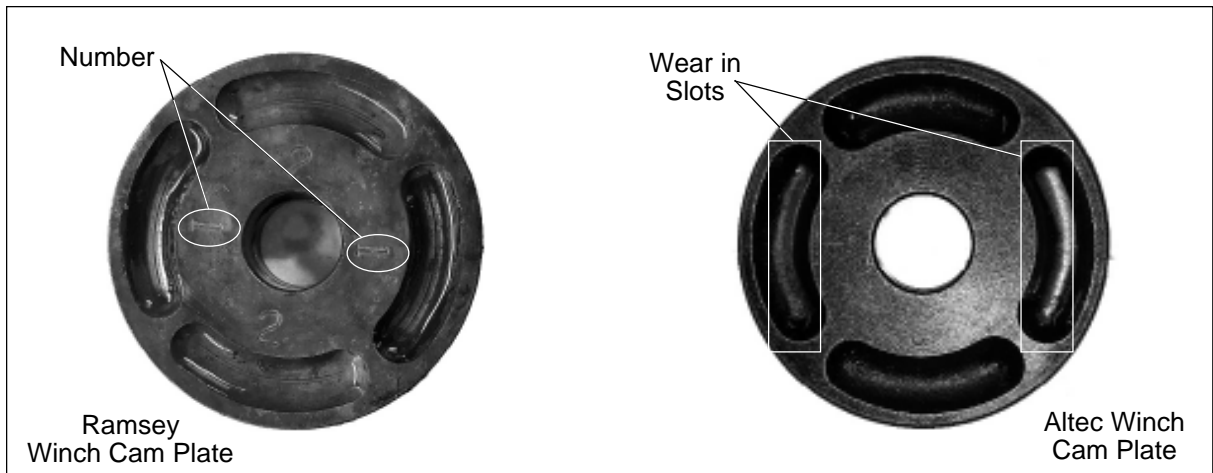

Figure 4 — Cam Plate Position

29. Install the brake disk. Install retainer plate with the smooth side towards the brake disk, holes facing outwards.
30. Place the coil spring over the adjusting screw on the inside cover.
31. Place the two leaf springs on the retainer plate. Line the notches in the leaf springs up with the holes on the retainer plate.
32. Install the brake housing cover and gaskets, making sure the extended pins go through the leaf spring and into the holes on the retainer plate. NOTE: Apply pressure to keep the cover in place while reinstalling.
33. Install the brake housing cover onto the winch with the four mounting screws.
34. Make sure the drain plug is in place and add SAE 85W-140 gear oil to replace any oil that was lost.
35. Use the torque adapter to turn winch in the Winch Raise direction at least one turn of the input shaft.

36. Set the torque wrench to 13-15 ft.-lbs. Insert the brake torque adapter into the coupling on the input shaft and attach the torque wrench. Rotate the winch input shaft clockwise when facing the brake end (counterclockwise facing the input shaft end). Tighten the adjusting screw on the winch brake by turning it about $\frac{1}{8}$ of a turn or less, while continuously checking the torque until the brake holds when 13-15 ft.-lbs of torque is applied to the input shaft. **CAUTION:** Do not over tighten. This can damage the brake parts and cause overheating. If the specified torque can not be reached while tightening the adjustment screw, the friction disk may need to be replaced. **NOTE:** The friction disk will receive the same amount of wear regardless of the clutch orientation. Any excessive wear of the friction disk comes from use over time and is not a result of improper clutch installation.
37. Tighten the lock nut and check the torque again to be sure it did not change when the adjustment nut was tightened. Readjust as needed. Check the torque at least four times to make sure the adjustment is correct before continuing to Step 38.
38. Reinstall the winch motor and tighten the fasteners securely. Reconnect the hoses to the motor.
39. Engage the unit's hydraulic system. Operate winch Raise and Lower control checking for leaks and proper operation. Make any corrections necessary.
40. Reinstall all covers on the winch. Stow the booms and retract the outriggers. Disengage the unit's hydraulic system. Return the unit to service.
41. Complete the inspection form at the end of this CSN and return it to Altec.

CSN 643 Inspection Sheet

Complete this form and FAX to: 1-877-659-9929

or scan and email to product.safety@altec.com

Model	Serial Number	Winch Brake is Correct		Date Inspected
		Yes	No	

Make additional copies of this form, as needed, for additional units. Contact Technical Support at 1-877-GO ALTEC (1-877-462-5832), prompt 4, for further repair information.

Company Name: _____ Phone _____

Service Company Name: _____ Phone: _____

Company Contact: _____

Company Street Address: _____

State: _____ ZIP Code: _____

Signature: _____