

IMPORTANT UPDATE

TECHNICAL INSTRUCTIONS FOR SAFETY RECALL GLH FRONT PASSENGER AIRBAG MODULE CERTAIN 2007 – 2010 MY ES 350 **UPDATED 4-18-2018**

Update 4-18-18

- The parts section has been updated

Update 1-9-18

- Added 2010 MY

Update 11-2-17

- Added 2009 MY

The repair quality of covered vehicles is extremely important to Lexus. All dealership technicians performing this recall are required to successfully complete the most current version of the E-Learning course "Safety Recall and Service Campaign Essentials". To ensure that all vehicles have the repair performed correctly:

- MASTER SERVICE TECHNICIANS
- MASTER DIAGNOSTIC SPECIALISTS

It is the dealership's responsibility to select technicians with the above certification level or greater to perform this recall repair. Carefully review your resources, the technician skill level, and ability before assigning technicians to this repair. It is important to consider technician days off and vacation schedules to ensure there are properly trained technicians available to perform this repair at all times.

NOTE: To support additional service capacity, Lexus Certified and Senior Service Technicians, with at least 36 months Lexus experience AND L652 course credit, may also perform this repair following successful completion of course LSC13B.

I. OPERATION FLOW CHART

The flow chart is for reference only. **DO NOT** use it in place of the full technical instructions. Follow **ALL** steps as outlined in the full technical instructions to confirm the campaign is completed correctly.

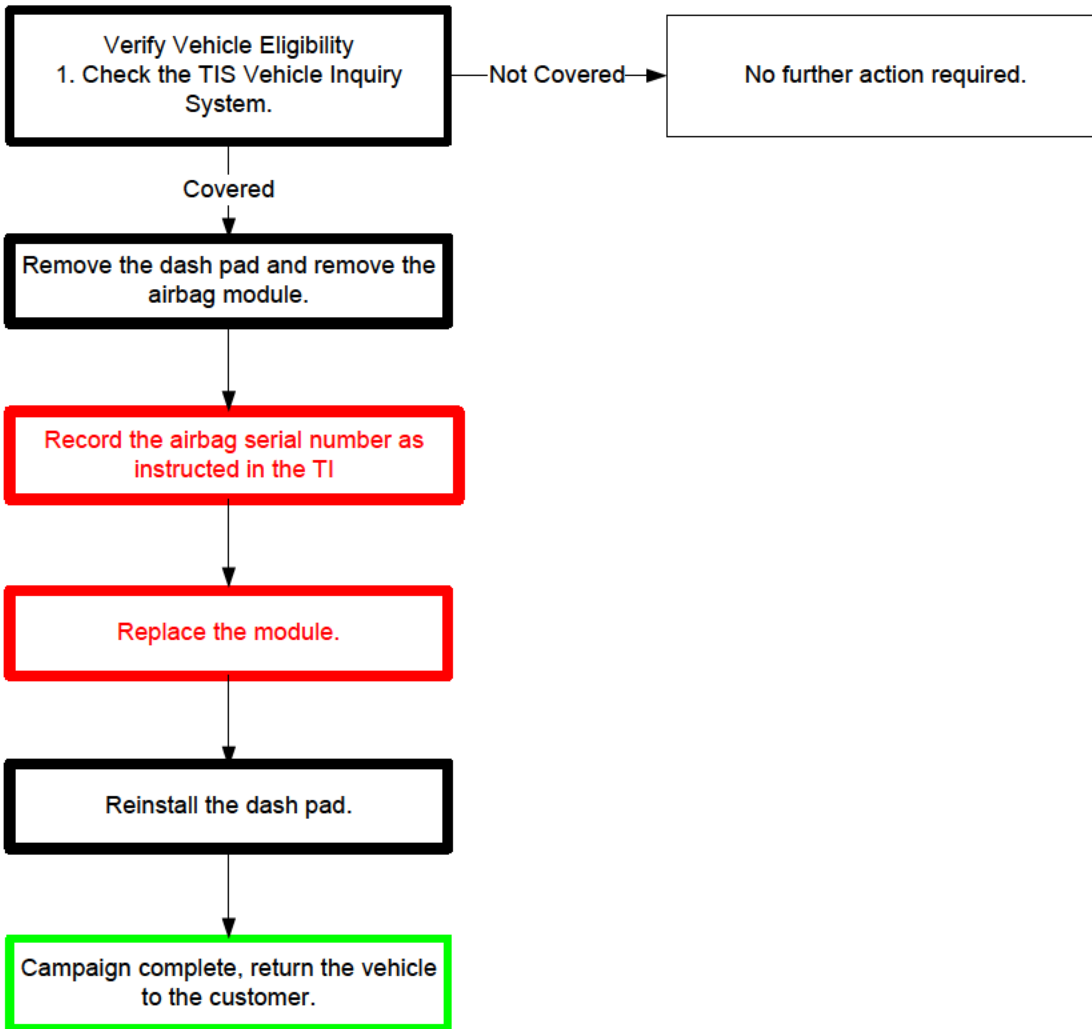

II. BACKGROUND

The subject vehicles are equipped with front passenger airbag inflators produced by Takata. The propellant in these inflators may degrade after prolonged exposure to high absolute humidity and fluctuating high temperatures. Degraded propellant can cause inflator rupture during airbag deployment. In the event of an inflator rupture, metal fragments could pass through the airbag cushion material, striking the vehicle occupants, and result in serious injury or death.

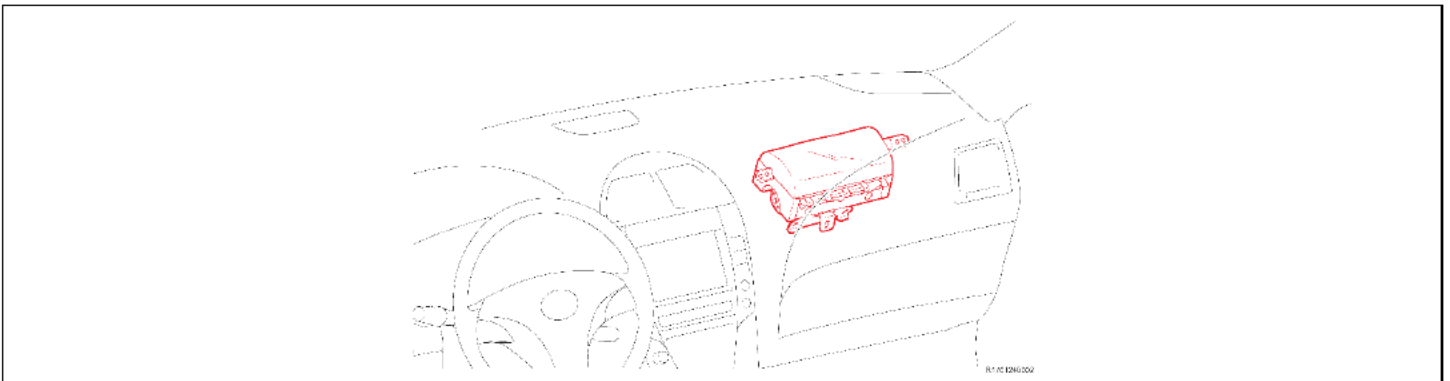

III. IDENTIFICATION OF AFFECTED VEHICLES

A. COVERED VIN RANGE

- Check the TIS Vehicle Inquiry System to confirm the VIN is involved in this Safety Recall, and that the campaign has not already been completed prior to dealer shipment or by another dealer.
- **TMS warranty will not reimburse dealers for repairs conducted on vehicles that are not affected or were completed by another dealer.**

IV. PREPARATION

A. PARTS

Part Number	Part Description	Quantity
04006-49233	Instrument Panel Passenger Airbag	1
04006-66108*	Front Pillar Garnish Kit (*kit contains 2 clips)	1

OR

Part Number	Part Description	Quantity
04007-06733	Instrument Panel Passenger Airbag Inflator Kit (Instructions for this part are in the inflator replacement TI)	1
04006-66108*	Front Pillar Garnish Kit (*kit contains 2 clips)	1

If using the part mentioned above, follow the instructions in the Inflator replacement TI

Non-Desiccated Part Recovery

Dealers should discontinue the installation of the non-desiccated parts listed below for recall, customer pay repairs AND over-the-counter sales (if applicable).

Model	Model Year	Part Number	Part Description
ES350	2007-2012	73960-33110 73960-33111	AIR BAG ASSY, INSTR PNL PASS L/DOOR

Lexus requires all dealers to return any parts listed above that still remain in dealer inventory by utilizing the Hazmat Part Return Program available. Dealers will be issued a refund for all part returns. This part return program is outlined in *PANT Bulletin 2014-042*.

Important Note:

In order to return the inflator, packages must **NOT** be opened/tampered with.

B. TOOLS & EQUIPMENT

- Standard hand tools
- Torque wrench
- Techstream
- Molding remover set

GLG/GLH CAMPAIGN TOOLS – These tools were previously provided to the dealership for campaign DLC and will be used for this campaign. These tools are required when performing this repair.

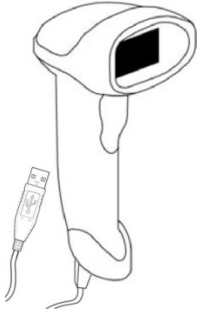
Image	Name	Quantity
	Barcode Scanner	1

NOTE: This tool **CANNOT** be ordered through the parts or tools system. If additional tools are needed, they can be sourced locally.

SST –These are essential service tools that the dealership should have.

Part Number	Part Name	Quantity
09950-50013	Puller C Set *	1
* The set above includes the following tools.		
Part Number	Part Name	Quantity
09951-05010	Hanger 150	1
09952-05010	Slide Arm	2
09953-05020	Center Bolt 150	1
09954-05021	Claw No. 2	2

V. SAFETY PRECAUTIONS

STOP

CRITICAL INFORMATION – READ THOROUGHLY

STOP

Failure to follow these procedures correctly could cause the SRS to unexpectedly deploy during servicing or the SRS may fail to operate correctly when required after reassembly. Confirm all work is performed as described in these instructions.

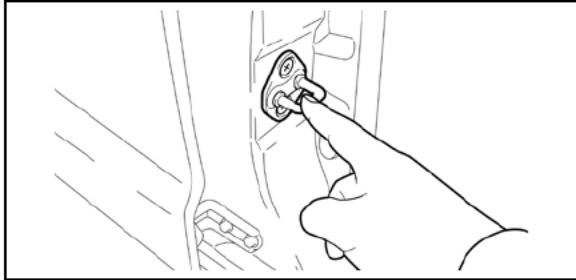

1. ELIMINATE STATIC ELECTRICITY

- a) Before starting work and periodically while working on the vehicle, touch a metallic part of the vehicle to discharge static electricity in the body.

NG DO NOT measure resistance.

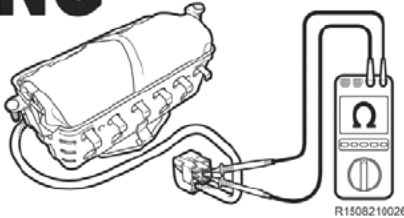

2. DO NOT MEASURE RESISTANCE

- a) **NEVER** measure the resistance of an airbag, this may cause accidental activation.

NG Replace with new one.

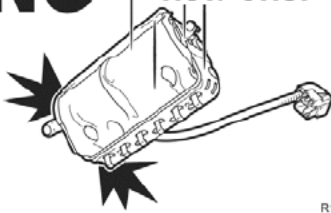

3. HANDLE THE AIRBAG CAREFULLY

- a) If the airbag is dropped, replace it with a **NEW** one.

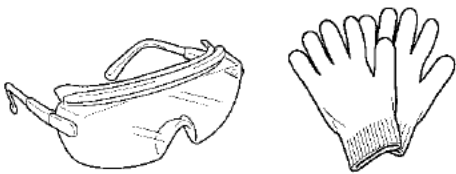

Wear protective eye wear and work gloves.

4. WEAR PROTECTIVE EQUIPMENT

- a) Always wear appropriate protective equipment when working on the SRS.

VII. FRONT PASSENGER AIRBAG REMOVAL COMPONENTS

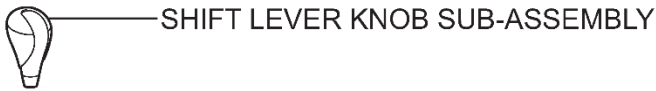

UPPER CONSOLE PANEL ASSEMBLY WITH FRONT ASH RECEPTACLE

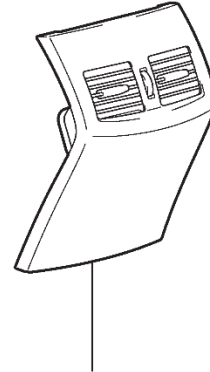
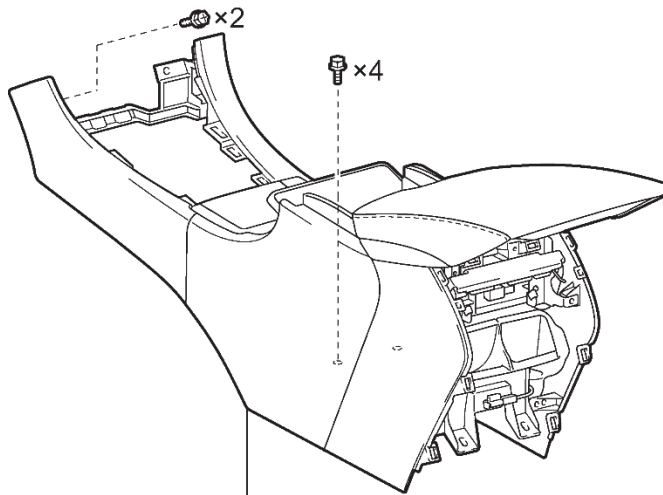
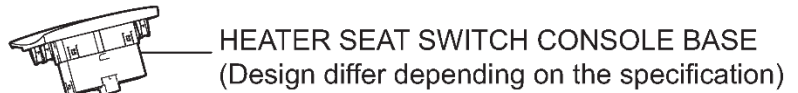
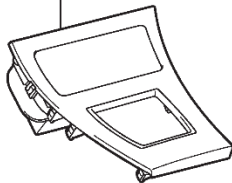

CONSOLE REAR END PANEL SUB-ASSEMBLY

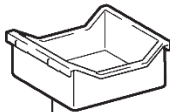

CONSOLE BOX POCKET
(Design differ depending on the specification)

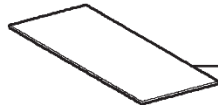

CONSOLE BOX CARPET

R1701240004

TURN SIGNAL SWITCH ASSEMBLY WITH SPIRAL CABLE SUB-ASSEMBLY

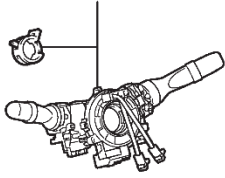

TILT AND TELESCOPIC SWITCH

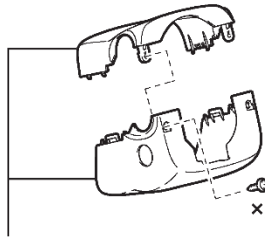

STEERING COLUMN COVER

2.0 (20, 18 in.*lbf)

x2

COMBINATION METER ASSEMBLY

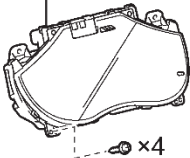

x4

STEERING WHEEL ASSEMBLY

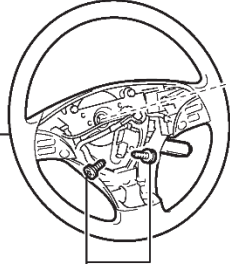

50 (510, 37)

LOWER No. 3 STEERING WHEEL COVER



8.8 (90, 78 in.*lbf)

LOWER No. 2 STEERING WHEEL COVER



INSTRUMENT CLUSTER FINISH PANEL SUB-ASSEMBLY

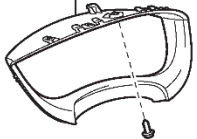

LOWER INSTRUMENT PANEL RH

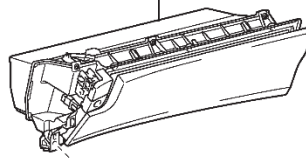

x6

STEERING PAD



SIDE INSTRUMENT PANEL LH



FRONT PASSENGER SIDE KNEE AIRBAG ASSEMBLY

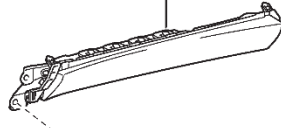

x3

10 (102, 7)

SIDE INSTRUMENT PANEL RH

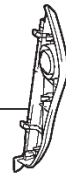

No. 1 SWITCH HOLE BASE

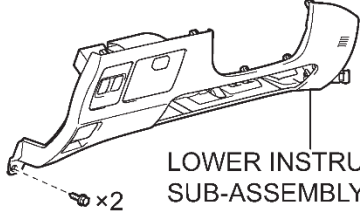
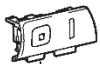

LOWER INSTRUMENT PANEL SUB-ASSEMBLY

x2

FRONT DOOR OPENING TRIM COVER RH



FRONT DOOR OPENING TRIM COVER LH



INSTRUMENT PANEL FINISH PANEL END RH

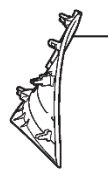

INSTRUMENT PANEL FINISH PANEL END LH



FRONT DOOR SCUFF PLATE RH

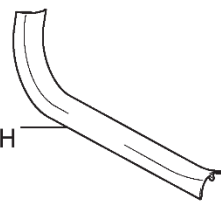

FRONT DOOR SCUFF PLATE LH

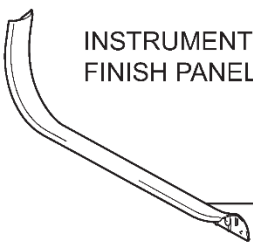

No.2 INSTRUMENT PANEL UNDER COVER SUB-ASSEMBLY

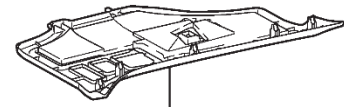

N*m (kgf*cm, ft*lbf) : Specified torque

R1701240005

● FRONT PILLAR GARNISH CLIP

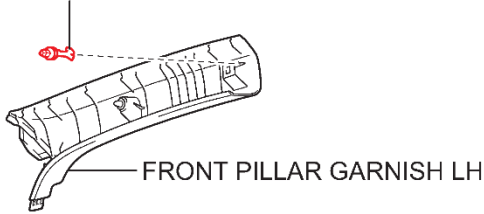

● FRONT PILLAR GARNISH CLIP

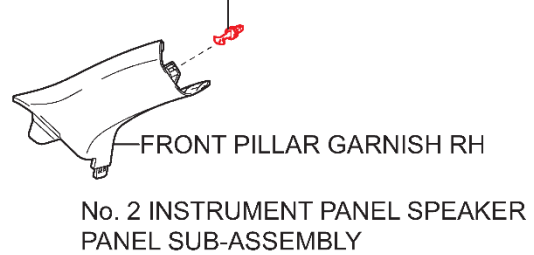

No. 1 INSTRUMENT PANEL SPEAKER PANEL SUB-ASSEMBLY

No. 1 SPEAKER HOLE COVER

INSTRUMENT PANEL SAFETY PAD ASSEMBLY

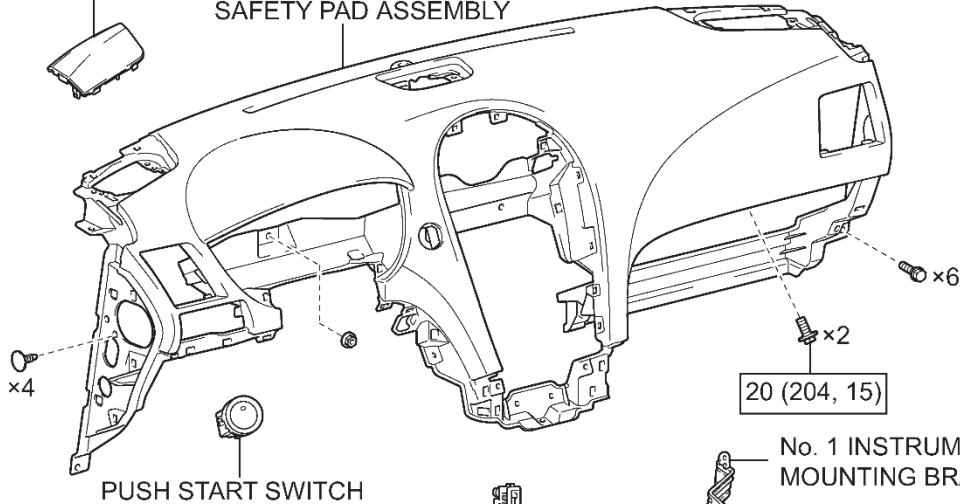

PUSH START SWITCH

ROOM TEMPERATURE SENSOR

FRONT STEREO COMPONENT SPEAKER ASSEMBLY
(Design differ depending on the specification)

FRONT No. 2 SPEAKER ASSEMBLY
(Design differ depending on the specification)

FRONT No. 2 SPEAKER ASSEMBLY
(Design differ depending on the specification)

No. 2 INSTRUMENT PANEL REGISTER ASSEMBLY

No. 1 INSTRUMENT PANEL REGISTER ASSEMBLY

No. 3 INSTRUMENT PANEL REGISTER ASSEMBLY

INTEGRATION CONTROL PANEL or MULTI-DISPLAY or DISPLAY AND NAVIGATION MODULE DISPLAY WITH RADIO RECEIVER ASSEMBLY

● Replacement part

N*m (kgf*cm, ft*lb) : Specified torque

R1701240006

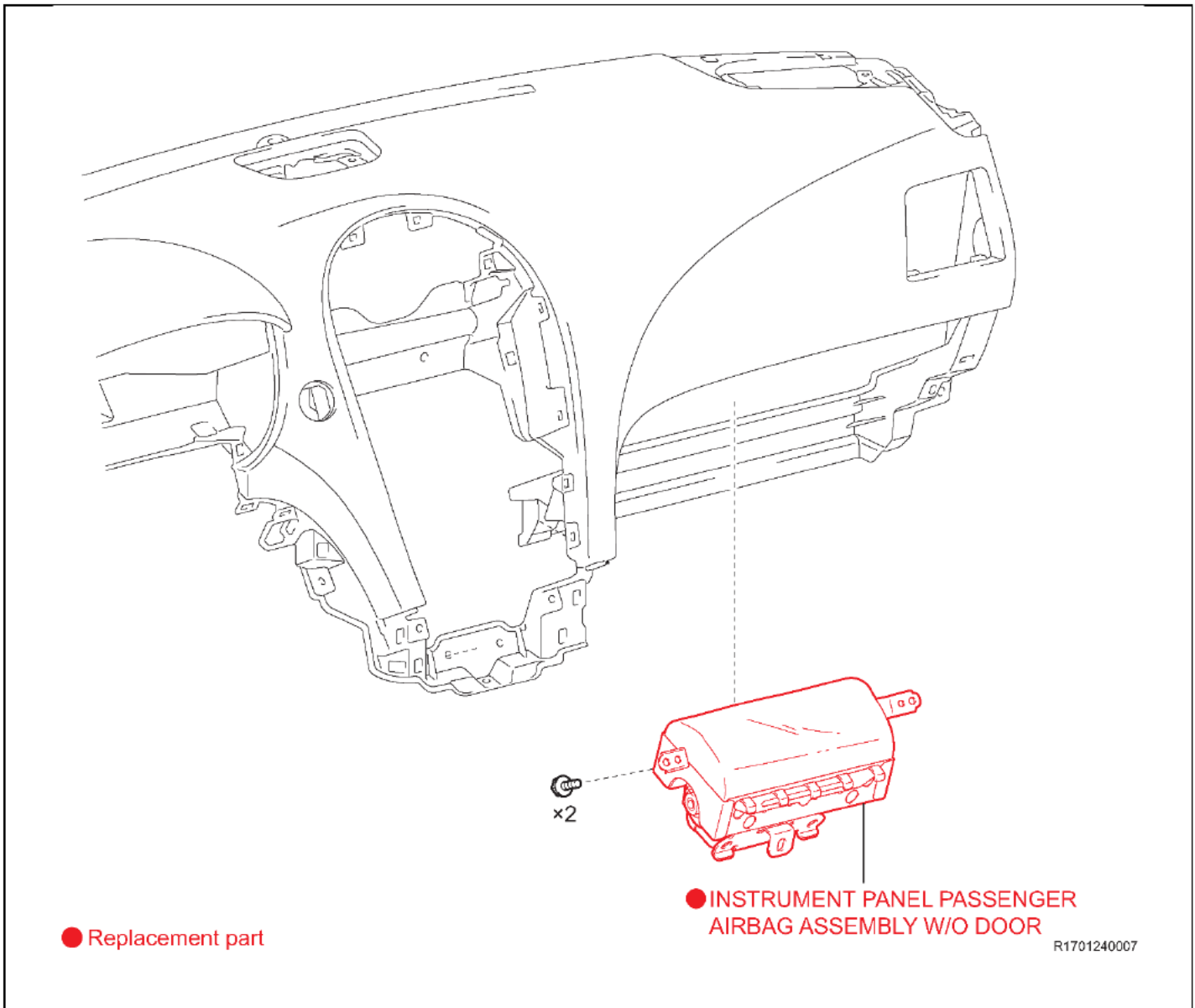

1. REMOVE THE AIRBAG MODULE



- Wait at least 90 seconds after disconnecting the cable from the negative battery terminal to prevent airbag and seat belt pre-tensioner deployment.
- Follow all precautions as outlined on TIS before servicing the SRS system.

a) Refer to TIS for removal instructions.

[2007 MY](#) | [2008 MY](#) | [2009 MY](#) | [2010 MY](#)

2. CONNECT THE BARCODE SCANNER

- Connect the barcode scanner to the USB port on the Techstream.
- The scanner will automatically connect and a beep will be heard when the scanner is ready.

NOTE:

- The scanner was provided for SSC DLC.
- The barcode scanner works best in low light conditions.
- Always hold the scanner directly in front of and parallel to the barcode label.

3. SCAN THE AIRBAG SERIAL NUMBER

ATTENTION: This information is **CRITICAL**

- Scan the **AIRBAG ASSEMBLY** serial number 2 times.
 - Confirm that the cursor is in the first serial number box and scan the bar code.
 - Position the cursor in the second serial number box and rescan the bar code.
- Click next.

NOTE:

- If the serial numbers do not match, confirm and reenter.
- If the serial number barcode will not scan, it can be entered manually.

AIRBAG SERIAL NUMBER IDENTIFICATION

- The airbag serial number is **ALWAYS** the **12 DIGITS** located between the asterisks.
- The 3 digits before the asterisk **ARE NOT** part of the serial number, and **SHOULD NOT** be entered or an inaccurate response may be returned.

Airbag Serial Number Label Example



The **AIRBAG ASSEMBLY** serial number **MUST** be recorded prior to replacement.

Front Passenger Airbag Inflator Module - Safety Recall

SSC DSC

1 2 3 4 5

User ID:

Technician Name:

Dealer Code:

Dealer Name:

Time: 03/30/2015 05:15 AM PDT

VIN:

[2004 Corolla SUPER WHITE]

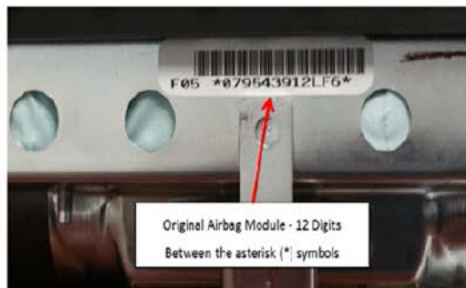

Original Airbag Module - 12 Digits
Between the asterisk (*) symbols

Record Airbag Serial Number

How to Identify an Airbag module Assembly number?

The Airbag module Assembly serial number is a **12 digit code**. It can be found along with a bar code on opening the Airbag assembly unit. To manually enter these details into the application, the technician has to identify the 12 digit code between two Asterisks (*) inside the Airbag assembly unit. The first seven characters of this 12 digit code are numbers and the 10th digit is either 'K' or 'L' always.

Use of a barcode scanner is strongly recommended when entering Airbag Assembly Serial Number.

If manually typing serial number, you **MUST** include all leading zeros. (If applicable)

* Airbag Assembly Serial Number:

* Reconfirm Airbag Assembly Serial Number:

If original Airbag Assembly serial number is not visible or missing, check this box

(*) - Indicates Required Field(s)

Clear Next

- c) Check the box that states that the inflator serial number is not visible or missing.
(DO NOT SCAN THE INFLATORS)
 (this will allow the program to advance to the next screen)

Front Passenger Airbag Inflator Module - Safety Recall
 SSC - E04

User ID: _____
 Dealer Code: _____
 Time: 03/30/2015 05:17 AM PDT

1 2 3 4 5

Technician Name: _____
 Dealer Name: _____
 Airbag Serial #: *****12

VIN: _____ [2004 Corolla SUPER WHITE]

Original Inflator



How to identify the Inflator serial code on the Original and Replacement inflator can?

The Inflator serial code is an **11 digit code** on the Inflator can. It can be found with a bar code on removing the Inflator can from the Airbag Assembly unit.

The first two characters of the **Original Inflator Serial code** will be from [AA, AB, AJ, FD or JD].

The first two characters of the **Replacement Inflator Serial code** will be either 'LT' or 'LR'.

Replacement Inflator



Inflator Module replacement IS REQUIRED on all vehicles under the Safety Recall. Follow the technical instructions and acknowledge the following statements.

If manually typing serial number, you MUST include all leading zeros. (If applicable)

Original Inflator Serial #:

If old inflator serial number is not visible or missing, check this box

* Replacement Inflator Serial #:

If you have a concern with the inflator serial numbers, please email quality_compliance@toyota.com with details.

I agree to complete the safety recall's remaining technical instructions.

I agree to perform a vehicle Health Check with Techstream upon completion of the safety recall's technical instructions.

(*) - Indicates Required Field(s)

Back Clear

- d) Confirm agreement by checking the two boxes and press submit.

NOTE: The NEW AIRBAG ASSEMBLY serial number MUST be scanned prior to reinstallation to track the airbag to the vehicle (refer to page 13).

e) Scan the **NEW** Airbag barcode in the Serial Number Recording Application.

Front Passenger Airbag Inflator Module - Safety Recall

SSC DSC

1 2 3 4 5

User ID: _____ Technician Name: _____
Dealer Code: _____ Dealer Name: _____
Time: 03/30/2015 05:15 AM PDT VIN: [2004 Corolla SUPER WHITE]

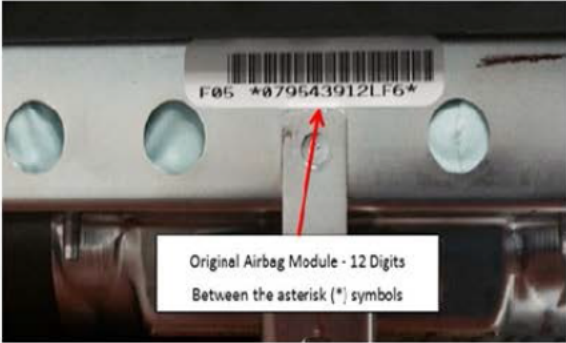

Original Airbag Module - 12 Digits
Between the asterisk (*) symbols

[How to Identify an Airbag module Assembly number?](#)

The Airbag module Assembly serial number is a **12 digit code**. It can be found along with a bar code on opening the Airbag assembly unit. To manually enter these details into the application, the technician has to identify the 12 digit code between two Asterisks (*) inside the Airbag assembly unit. The first seven characters of this 12 digit code are numbers and the 10th digit is either 'K' or 'L' always.

Record Airbag Serial Number

Use of a barcode scanner is strongly recommended when entering Airbag Assembly Serial Number.

If manually typing serial number, you **MUST** include all leading zeros. (If applicable)

*New Airbag Assembly Serial Number:

I agree to complete the safety recall's remaining technical instructions.

I agree to perform a vehicle Health Check with Techstream upon completion of the safety recall's technical instructions.

(*) - Indicates Required Field(s)

Next

f) Confirm agreement by checking the two boxes and press next.



The new **AIRBAG ASSEMBLY** serial number **MUST** be recorded prior to reinstallation to track the airbag to the vehicle.

g) Record the Warranty Authorization # to be included in the warranty claim.

T3 :: SuzukiR - Google Chrome
t3qa.tms.toyota.com/t3Portal/portlets/tis/airBag/AirBagController.portlet?_nfpb=true&_windowLabel=Standal

Front Passenger Airbag Inflator Module - Safety Recall

SSC - DSF

1 2 3 4 5

User ID: SuzukiR **Technician Name:** Russell Suzuki
Dealer Code: **Dealer Name:**
Time: 06/10/2014 05:13 PM PDT **Airbag Serial #:** *****96
Original Inflator Serial #: AAEL5110212 **Replacement Inflator Serial #:** AAEL5110213

SuzukiR has agreed to the following terms and conditions on 06/10/2014 05:13 PM PDT

- * I agree to complete the safety recall's remaining technical instructions.
- * I agree to perform a vehicle Health Check with Techstream upon completion of the safety recall's technical instructions.

Russell Suzuki has successfully confirmed completion of Airbag Inflator Module Safety Recall for

VIN - : **[2003 Sequoia BEIGE M. M.]**

Warranty Authorization #: b5511e9f

Airbag inflator module was replaced under this safety recall.

Print this page for your records and then click 'Close' to resume working.

Close

h) Confirm agreement by checking the two boxes.

i) Place the old airbag in the parts box and return it to the parts department.

NOTE:

- Keep all shipping paperwork with the box that it came in.
- Confirm the cursor is in the correct serial number input box before scanning.
- If the serial number barcode will not scan, it can be entered manually.
- If there are any difficulties or concerns with this process, email quality_compliance@toyota.com with details.

AIRBAG SERIAL NUMBER IS MISSING OR IS UNREADABLE



If the airbag serial number and barcode are not legible or are not present, check the box in the application indicating the serial number is not legible.

a) If the airbag serial number cannot be scanned or is not present check the box as shown below.

Front Passenger Airbag Inflator Module - Safety Recall
SSC DSC

(1) (2) (3) (4) (5)

User ID: _____ Technician Name: _____
Dealer Code: _____ Dealer Name: _____

Time: 03/30/2015 05:15 AM PDT VIN: [2004 Corolla SUPER WHITE]



Record Airbag Serial Number

[How to Identify an Airbag module Assembly number?](#)

The Airbag module Assembly serial number is a 12 digit code. It can be found along with a bar code on opening the Airbag assembly unit. To manually enter these details into the application, the technician has to identify the 12 digit code between two Asterisks (*) inside the Airbag assembly unit. The first seven characters of this 12 digit code are numbers and the 10th digit is either 'K' or 'L' always.

Use of a barcode scanner is strongly recommended when entering Airbag Assembly Serial Number.
If manually typing serial number, you MUST include all leading zeros. (If applicable)

* Airbag Assembly Serial Number:

* Reconfirm Airbag Assembly Serial Number:

If original Airbag Assembly serial number is not visible or missing, check this box

Clear Next

(*) - Indicates Required Field(s)

Check this box if the label is damaged or missing

b) Return to Page 13 and continue.

IX. VEHICLE REASSEMBLY

1. INSTALL THE NEW AIRBAG ASSEMBLY INTO THE INSTRUMENT PANEL

2. REINSTALL THE DASH

a) Refer to TIS for reinstallation instructions

2007 MY	2008 MY	2009 MY	2010 MY
-------------------------	-------------------------	-------------------------	-------------------------

3. RECONNECT THE NEGATIVE BATTERY CABLE

4. PERFORM A HEALTH CHECK AND DIAGNOSTIC REPORT

5. PERFORM ANY NEEDED SYSTEM INITIALIZATIONS

◀ VERIFY REPAIR QUALITY ▶

- Confirm all precautions are followed to ensure safety during the repair
 - Confirm the entire serial number checker application is completed and the warranty authorization # is recorded on **EVERY** vehicle
 - Confirm the old airbag is handled safely and given to the appropriate parts professional for shipment
- If you have any questions regarding this update, please contact your area representative.

X. APPENDIX

A. CAMPAIGN DESIGNATION DECODER

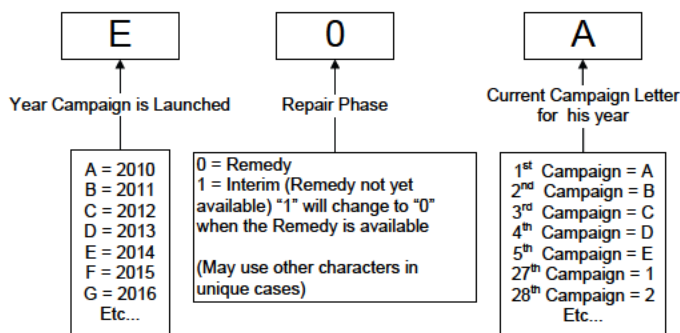

Examples:

A0D = Launched in 2010, Remedy Phase, 4th Campaign Launched in 2010

B1E = Launched in 2011, Interim Phase, 5th Campaign Launched in 2011

C1C = Launched in 2012, Interim Phase, 3rd Campaign Launched in 2012

B. CAMPAIGN PARTS DISPOSAL

ALL airbags that are removed from vehicles under this campaign **MUST** be packaged and shipped back to the manufacturer following the manufacturer's instructions. The instructions can be found in the following locations:

- Attached to the dealer letter
- Included in the parts box