

IMPORTANT UPDATE

TECHNICAL INSTRUCTIONS FOR SAFETY RECALL G0P FRONT PASSENGER AIRBAG INFLATOR CERTAIN 2008 – 2013 MY SCION xB

Updated 1-9-18

Update 1-9-18

- Added 2013 MY

The repair quality of covered vehicles is extremely important to Toyota. All dealership technicians performing this repair are required to successfully complete the most current version of the E-Learning course “Safety Recall and Service Campaign Essentials”. To ensure that all vehicles have the repair performed correctly; technicians performing this repair are required to currently hold at least one of the following certification levels:

- Toyota Expert (Electrical)
- Master
- Master Diagnostic Technicians

Always check which technicians can perform the recall remedy by logging on to <https://www.uotdealerreports.com>. It is the dealership’s responsibility to select technicians with the above certification level or greater to perform this repair. Carefully review your resources, the technician skill level, and ability before assigning technicians to this repair. It is important to consider technician days off and vacation schedules to ensure there are properly trained technicians available to perform this repair at all times.

I. OPERATION FLOW CHART

The flow chart is for reference only. **DO NOT** use it in place of the full technical instructions. Follow **ALL** steps as outlined in the full technical instructions to confirm the campaign is completed correctly.

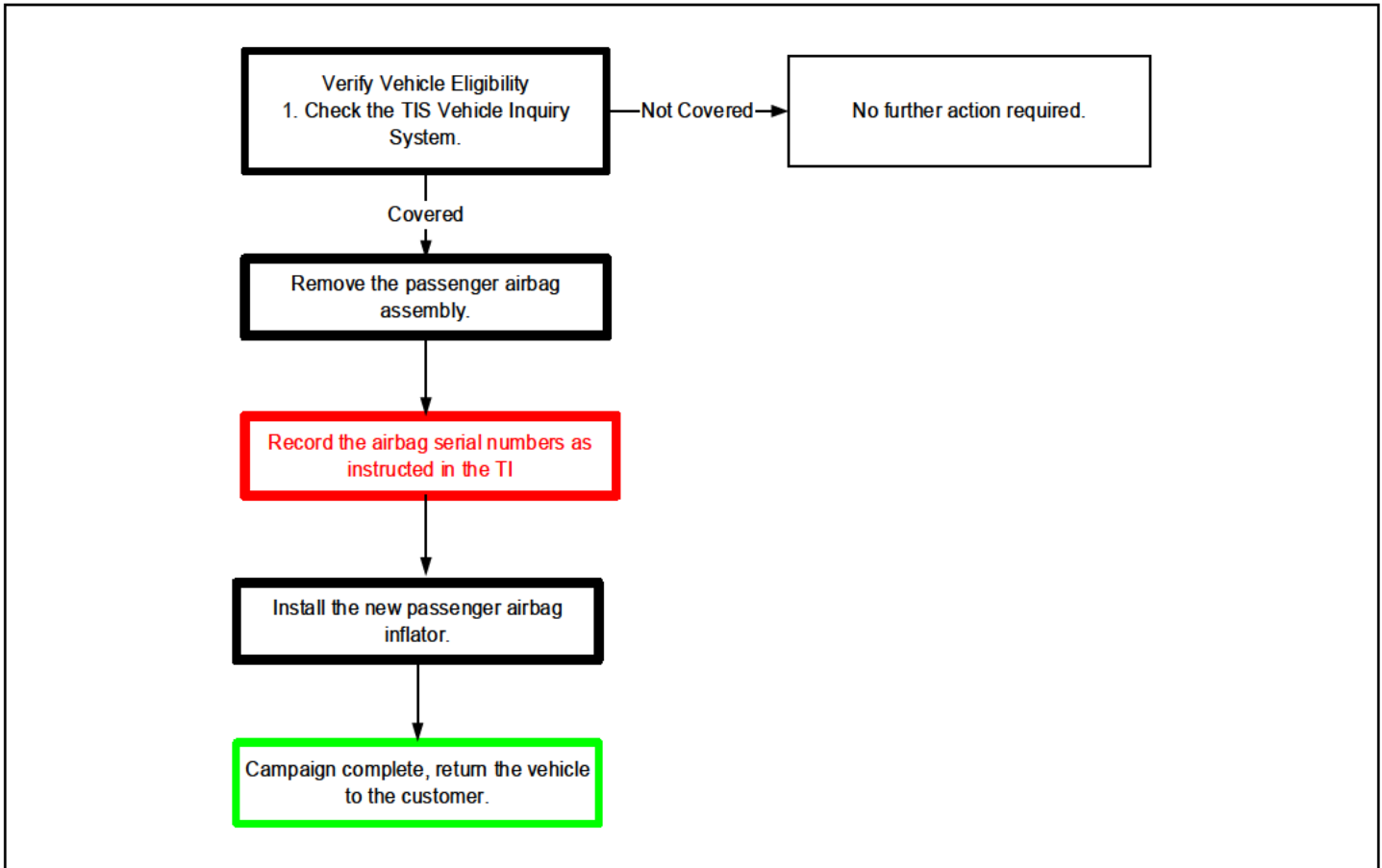

II. BACKGROUND

The subject vehicles are equipped with front passenger airbag inflators produced by Takata. According to Takata, the propellant in these inflators may degrade after prolonged exposure to high absolute humidity and fluctuating high temperatures. Degraded propellant can cause inflator rupture during airbag deployment. In the event of an inflator rupture, metal fragments could pass through the airbag cushion material, striking the vehicle occupants, and result in serious injury or death.

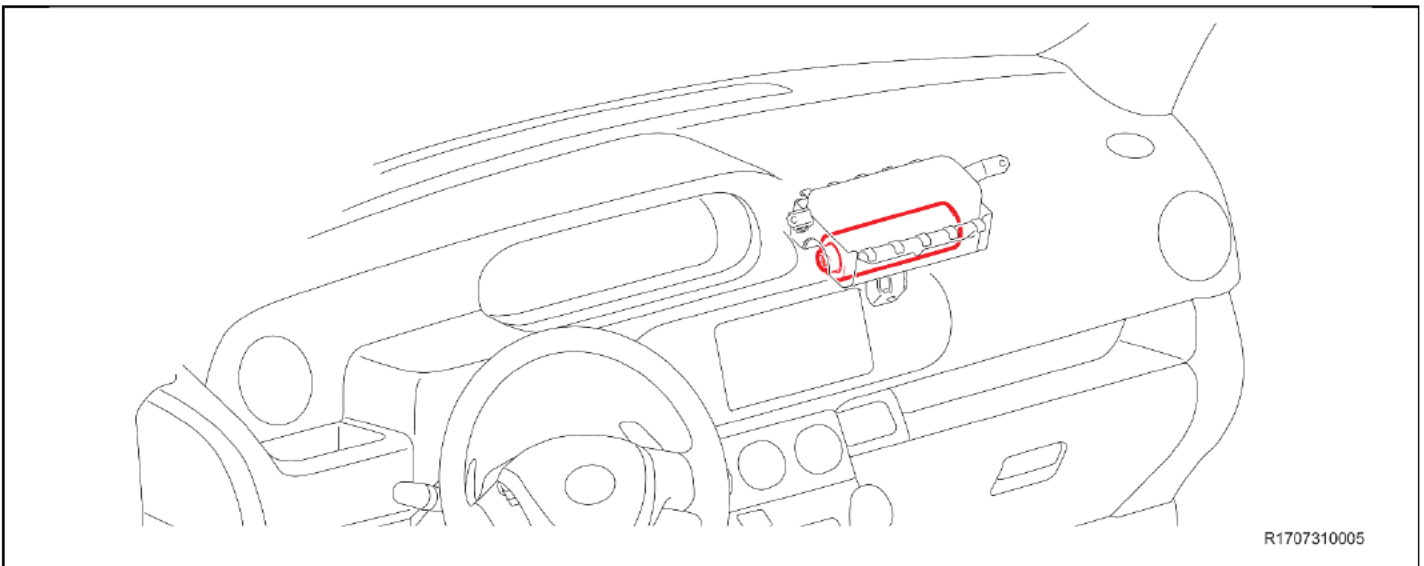

III. IDENTIFICATION OF AFFECTED VEHICLES

- Check the TIS Vehicle Inquiry System to confirm the VIN is involved in this Safety Recall, and that the campaign has not already been completed prior to dealer shipment or by another dealer.
- **TMS warranty will not reimburse dealers for repairs conducted on vehicles that are not affected or were completed by another dealer.**

IV. PREPARATION

A. PARTS

Part Number	Part Description	Quantity
04007-06812	Instrument Panel Airbag Inflator Kit*	1
* The kit above includes the following parts.		
Part Number	Part Description	Quantity
-	Inflator	1
-	Self-locking Nut	5
-	Position Determining Plate	1

Part Number	Part Description	Quantity
04006-66112	Clip Kit*	1
* The kit above includes the following parts.		
Part Number	Part Description	Quantity
-	Front Pillar Garnish Clip	2

OR

Model	Part Number	Part Description	Quantity
Scion xB	04006-49312	Instrument Panel Airbag Module (Instructions for this part are in the module replacement TI)	1
	04006-66108	Clip Kit*	1
* The kit above includes the following parts.			
	Part Number	Part Description	Quantity
		Front Pillar Garnish Clip	2

IF USING THE PART MENTIONED ABOVE, FOLLOW THE INSTRUCTIONS IN THE MODULE REPLACEMENT TI

A. TOOLS & EQUIPMENT

- Standard hand tools
- Torque wrench
- Techstream
- Molding remover set

B. MATERIALS

- Protective Tape
- Marker Pen

G0P/G0R/H0A CAMPAIGN TOOLS – These tools were previously provided to the dealership for campaign F0J and will be used for this campaign. These tools are required when performing this repair.

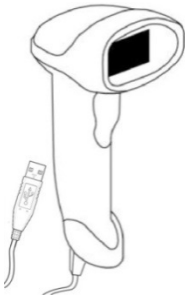
Image	Name	Quantity
	Barcode Scanner (The scanner distributed for F0J can read bar and QR codes)	1

NOTE: This tool **CANNOT** be ordered through the parts or tools system. If additional tools are needed, they can be sourced locally.

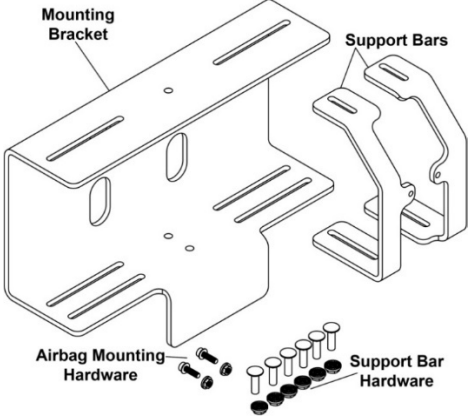
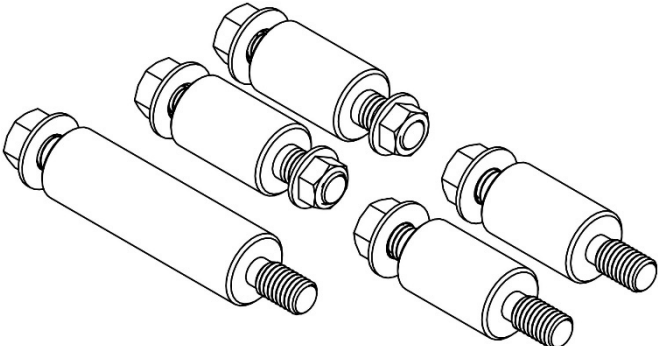
Image	Name	Quantity
	Airbag Mounting Bracket & hardware (Provided to the dealership at the launch of SSC DLC)	1
	579943 Adaptor set*	1

*The adapter set was sent to dealers prior to the start of this campaign.

SST –These are essential service tools that the dealership should have.

Part Number	Part Name	Quantity
09950-50013	Puller C Set *	1
* The set above includes the following tools.		
Part Number	Part Name	Quantity
09951-05010	Hanger 150	1
09952-05010	Slide Arm	2
09953-05020	Center Bolt 150	1
09954-05021	Claw No. 2	2

V. SAFETY PRECAUTIONS



CRITICAL INFORMATION – READ THOROUGHLY



Failure to follow these procedures correctly could cause the SRS to unexpectedly deploy during servicing or the SRS may fail to operate correctly when required after reassembly. Confirm all work is performed as described in these instructions.

DO NOT CONNECT PREMATURELY
CANNOT DISCONNECTED

NG



R170128000

1. **IMPORTANT NOTICE WHEN CONNECTING INSTRUMENT PANEL WIRE CONNECTOR TO AIRBAG INFLATOR**
 - a) Once connected, the instrument panel wire connector cannot be disconnected from the airbag inflator. If the instrument panel wire connector is incorrectly connected to the inflator, replace the instrument panel wire and inflator with new ones.

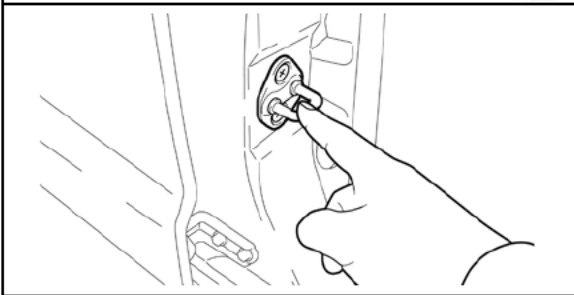

2. **ELIMINATE STATIC ELECTRICITY**
 - a) Before starting work and periodically while working on the vehicle, touch a metallic part of the vehicle to discharge static electricity in the body.

NG DO NOT
measure resistance.

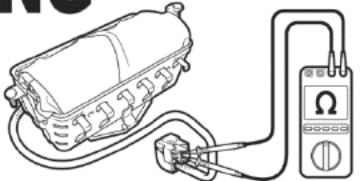

R1508210026

3. **DO NOT MEASURE RESISTANCE**
 - a) **DO NOT** measure resistance of airbag components, this may cause accidental activation.

NG Replace with
new one.

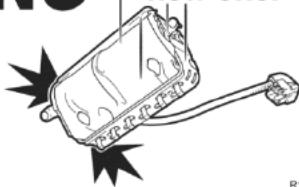

R1508210027

4. **HANDLE THE AIRBAG CAREFULLY**
 - a) If an airbag is dropped, replace it with a **NEW** one.

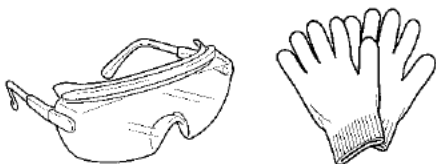

Wear protective eye wear
and work gloves.

5. **WEAR PROTECTIVE EQUIPMENT**
 - a) Always wear appropriate protective equipment when working on the SRS.

VII. PASSENGER AIRBAG MODULE REPLACEMENT

COMPONENTS

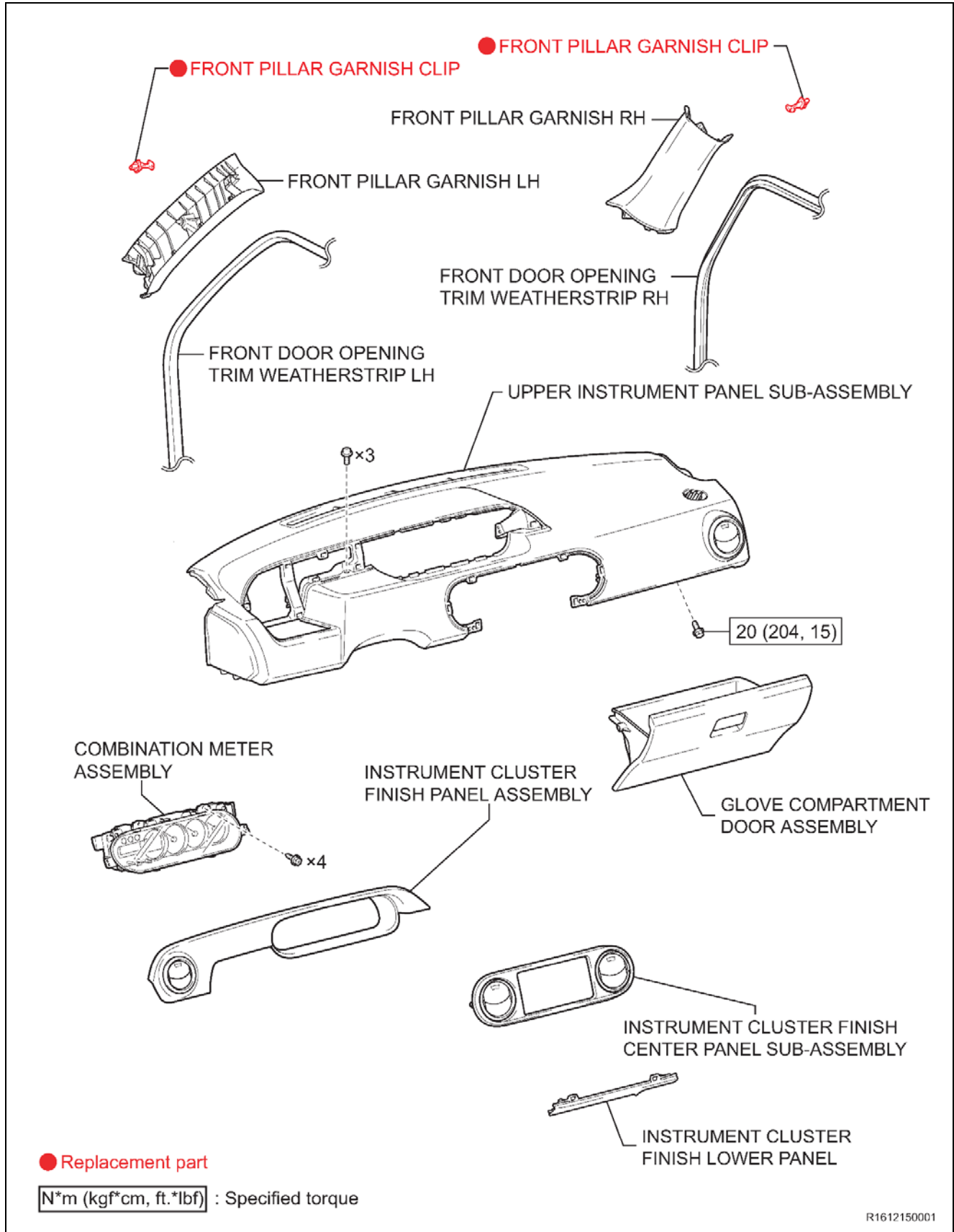

**3.9 N·m (40, 35 in.*lbf)
Be careful not to
overtighten.**

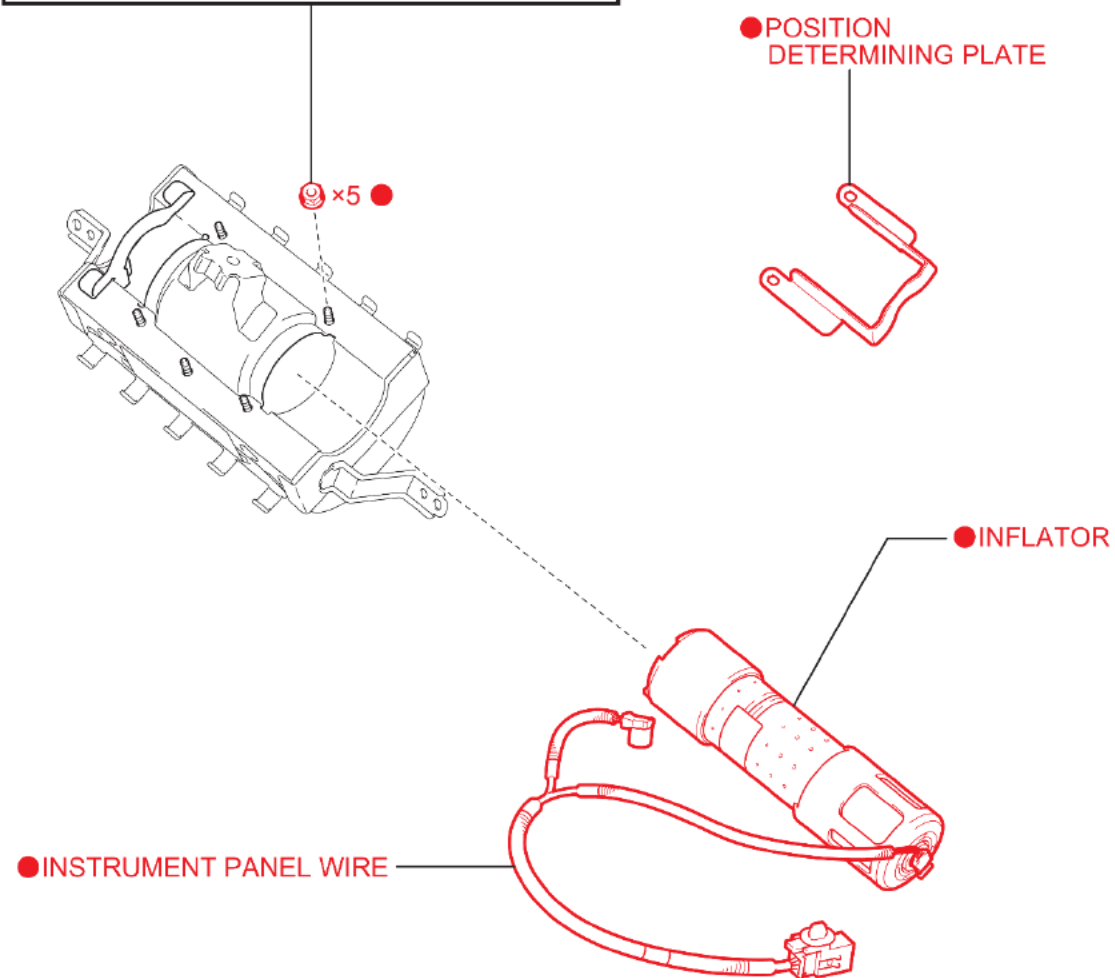

1. REMOVE THE AIRBAG MODULE

a) Refer to TIS for instructions on airbag removal:

[2008MY](#) [2009MY](#) [2010MY](#) [2011MY](#) [2012MY](#) [2013MY](#)



- Wait at least 90 seconds after disconnecting the cable from the negative battery terminal to prevent airbag and seat belt pre-tensioner deployment.
- Follow all precautions as outlined on TIS before servicing the SRS system.

2. REMOVE INFLATOR FROM THE AIRBAG MODULE

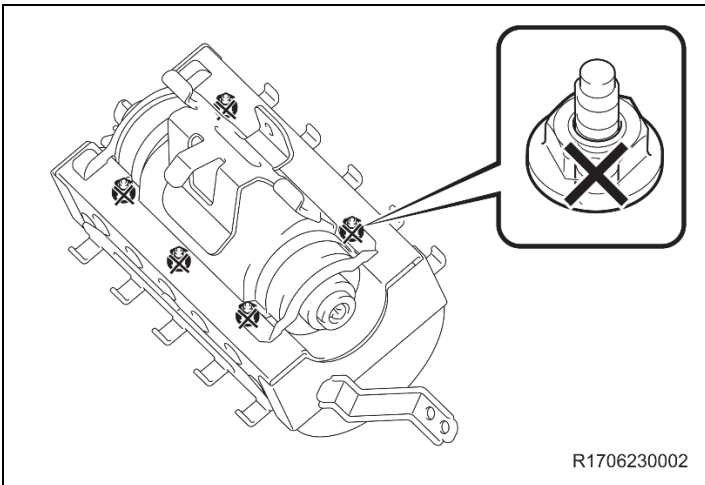

1. REMOVE THE INFLATOR

- a) Mark the 5 self locking nuts to prevent reuse.



- a) Mount the adaptors (579943-3R3) to the airbag as shown.

NOTE: The 6mm stud mounts to the airbag.



- b) Mount the airbag to the mounting bracket as shown.

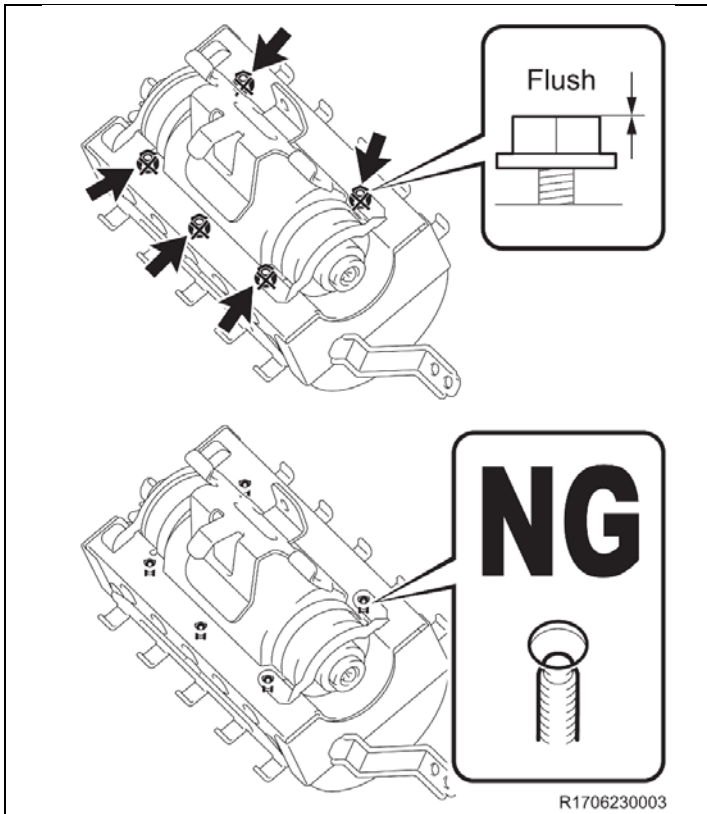

c) Loosen the 5 nuts until each nut is flush with the top of the stud as shown.

NOTE: You may need to slide the airbag to the left or right to access the middle nut. **DO NOT** use power tools to remove the nuts.

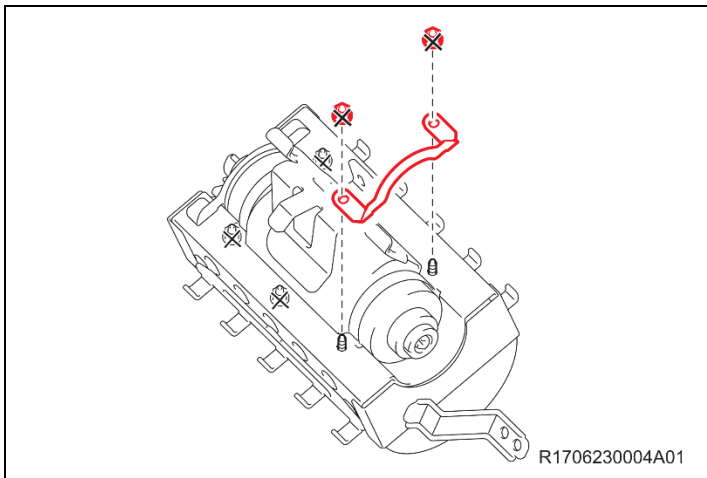

d) Loosen and discard the 2 nuts on the end where the positioning plate is removeable.
e) Remove and discard the plate.

NOTE:
DO NOT use power tools.

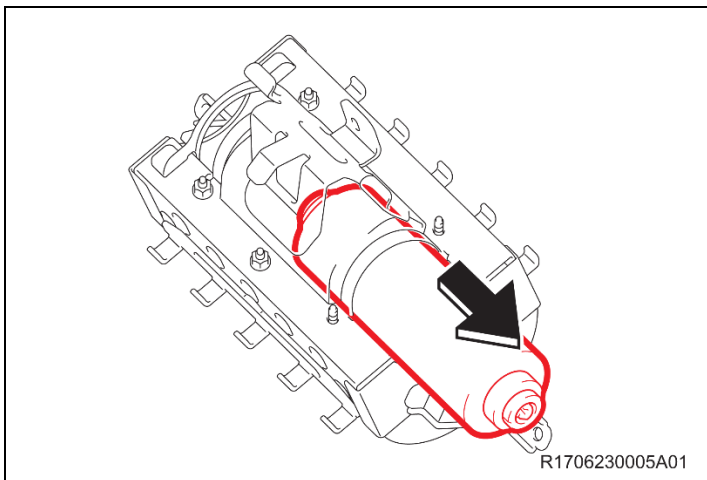

f) Remove the inflator.

- g) Mark the old inflator so it is not reused.
NOTE: Return the old inflator to the parts department for recovery.

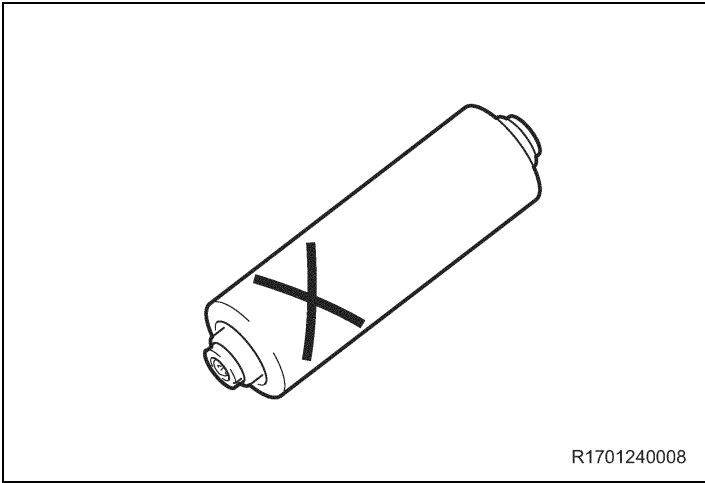

4. CONNECT THE BARCODE SCANNER

- Connect the barcode scanner to the USB port on the Techstream.
- The scanner will automatically connect and a beep will be heard when the scanner is ready.

NOTE:

- The scanner was provided for SSC F0J.
- The scanner works best in low light conditions.
- Always hold the scanner directly in front of and parallel to the barcode label.

5. SCAN THE AIRBAG SERIAL NUMBER

- Scan the **AIRBAG ASSEMBLY** serial number 2 times.
 - Confirm that the cursor is in the first serial number box then scan the bar code.
 - Position the cursor in the second serial number box and rescan the bar code.
- Click next.

NOTE:

- If both the serial numbers do not match, confirm and reenter.
- If the serial number barcode will not scan, it can be entered manually.

AIRBAG SERIAL NUMBER IDENTIFICATION

- The airbag serial number is **ALWAYS** the 12 **DIGITS** located between the asterisks.
- The 3 digits before the asterisk **ARE NOT** part of the serial number, and **SHOULD NOT** be entered or an inaccurate response may be returned.

Airbag Serial Number Label Example



STOP

The **AIRBAG** serial number **MUST** be recorded prior to replacement.

Front Passenger Airbag Inflator Module - Safety Recall
SSC - E04

User ID: Technician Name:
Dealer Code: Dealer Name:
Time: 03/30/2015 05:15 AM PDT VIN: 1NK BR32E [2004 Corolla SUPER WHITE]

Original Airbag Module - 12 Digits
Between the asterisk (*) symbols

Record Airbag Serial Number

Use of a barcode scanner is strongly recommended when entering Airbag Assembly Serial Number.
If manually typing serial number, you **MUST** include all leading zeros. (If applicable)

* Airbag Assembly Serial Number:
* Reconfirm Airbag Assembly Serial Number:

If original Airbag Assembly serial number is not visible or missing, check this box:

(*) - Indicates Required Field(s)

Click **Next**

Front Passenger Airbag Inflator Module - Safety Recall

SSC - E04

1 2 3 4

User ID:

Dealer Code:

Time: 03/30/2015 05:17 AM PDT

VIN: 1NX BR32E

[2004 Corolla SUPER WHITE]

Technician Name:

Dealer Name:

Airbag Serial #: *****12

Original Inflator

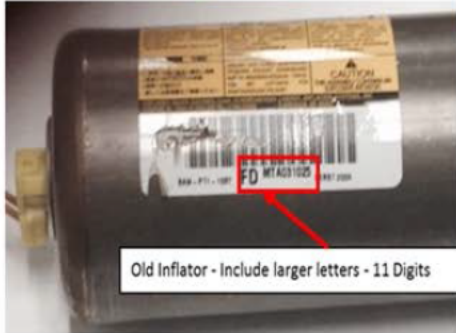

How to Identify the Inflator serial code on the Original and Replacement inflator can?

The Inflator serial code is an **11 digit code** on the Inflator can. It can be found with a bar code on removing the Inflator can from the Airbag Assembly unit.

The first two characters of the **Original Inflator Serial code** will be from [AA, AB, AJ, FD or JD].

The first two characters of the **Replacement Inflator Serial code** will be either 'LT' or 'LR'.

Replacement Inflator



Inflator Module replacement IS REQUIRED on all vehicles under the Safety Recall. Follow the technical instructions and acknowledge the following statements.

If manually typing serial number, you MUST include all leading zeros. (If applicable)

Original Inflator Serial #:

If old inflator serial number is not visible or missing, check this box.

Replacement Inflator Serial #:

If you have a concern with the inflator serial numbers, please email quality_compliance@toyota.com with details.

- I agree to complete the safety recall's remaining technical instructions.
- I agree to perform a vehicle Health Check with Techstream upon completion of the safety recall's technical instructions.

(*) - Indicates Required Field(s)

Back Clear **Sub**

c) Confirm agreement by checking the two boxes and press submit.

d) Record the Warranty Authorization # to be included in the warranty claim.

T3 :: SuzukiR - Google Chrome

t3qa.tms.toyota.com/t3Portal/portlets/tis/airBag/AirBagController.portlet?_nfpb=true&_windowLabel=Standal

Front Passenger Airbag Inflator Module - Safety Recall

SSC - DSF

1 2 3 4 5

User ID: SuzukiR **Technician Name:** Russell

Dealer Code: **Dealer Name:**

Time: 06/10/2014 05:13 PM PDT **Airbag Serial #:** *****96

Original Inflator Serial #: AAEL5110212 **Replacement Inflator Serial #:** AAEL5110213

SuzukiR has agreed to the following terms and conditions on 06/10/2014 05:13 PM PDT

- * I agree to complete the safety recall's remaining technical instructions.
- * I agree to perform a vehicle Health Check with Techstream upon completion of the safety recall's technical instructions.

Russell Suzuki has successfully confirmed completion of Airbag Inflator Module Safety Recall for

VIN - 5TD BT44A [2003 Sequoia BEIGE M. M.]

Warranty Authorization #: b5511e9f

Airbag inflator module was replaced under this safety recall.

Print this page for your records and then click 'Close' to resume working.

Close

e) Confirm agreement by checking the two boxes.

f) Place the old airbag in the parts box and return it to the parts department.

NOTE:

- Keep all shipping paperwork with the box that it came in.
- Confirm the cursor is in the correct serial number input box before scanning.
- If the serial number barcode will not scan, it can be entered manually.
- If there are any difficulties or concerns with this process, email quality_compliance@toyota.com with details.

AIRBAG SERIAL NUMBER IS MISSING OR IS UNREADABLE



If the airbag serial number and barcode are not legible or are not present, check the box in the application indicating the serial number is not legible.

a) If the airbag serial number cannot be scanned or is not present check the box as shown below.

Front Passenger Airbag Inflator Module - Safety Recall
SSC DSC

1 2 3 4 5

User ID: _____ Technician Name: _____
Dealer Code: _____ Dealer Name: _____

Time: 03/30/2015 05:15 AM PDT VIN: 1NX BR32E 2004 Corolla SUPER WHITE]

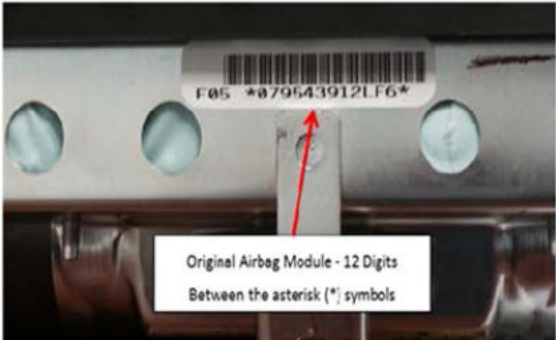

Record Airbag Serial Number

[How to Identify an Airbag module Assembly number?](#)

The Airbag module Assembly serial number is a **12 digit code**. It can be found along with a bar code on opening the Airbag assembly unit. To manually enter these details into the application, the technician has to identify the 12 digit code between two Asterisks (*) inside the Airbag assembly unit. The first seven characters of this 12 digit code are numbers and the 10th digit is either 'K' or 'L' always.

Use of a barcode scanner is strongly recommended when entering Airbag Assembly Serial Number.
If manually typing serial number, you **MUST** include all leading zeros. (If applicable)

* Airbag Assembly Serial Number:

* Reconfirm Airbag Assembly Serial Number:

If original Airbag Assembly serial number is not visible or missing, check this box:

(*) - Indicates Required Field(s)

Check this box if the Airbag serial number is not legible.
Note: Contact your area office in the event you are unable to read the serial number
DO NOT ATTEMPT TO INSTALL THE INFLATOR

- b) After the Area office approves the Airbag replacement and the new part is received, scan the new Airbag barcode in the Serial Number Recording Application.

Front Passenger Airbag Inflator Module - Safety Recall

SSC DSC

1 2 3 4 5

User ID: _____ Technician Name: _____
Dealer Code: _____ Dealer Name: _____
Time: 03/30/2015 05:15 AM PDT VIN: 1NX BR32E [2004 Corolla SUPER WHITE]



Record Airbag Serial Number

[How to Identify an Airbag module Assembly number?](#)

The Airbag module Assembly serial number is a **12 digit code**. It can be found along with a bar code on opening the Airbag assembly unit. To manually enter these details into the application, the technician has to identify the 12 digit code between two Asterisks (*) inside the Airbag assembly unit. The first seven characters of this 12 digit code are numbers and the 10th digit is either 'K' or 'L' always.

Use of a barcode scanner is strongly recommended when entering Airbag Assembly Serial Number.

If manually typing serial number, you MUST include all leading zeros. (If applicable)

*New Airbag Assembly Serial Number:

I agree to complete the safety recall's remaining technical instructions.

I agree to perform a vehicle Health Check with Techstream upon completion of the safety recall's technical instructions.

Next

(*) - Indicates Required Field(s)

- c) Confirm agreement by checking the two boxes and press next to advance to the Warranty authorization screen.
- d) Return the old airbag to the parts department.
- e) Proceed to Section IX Step 2.



The new **AIRBAG ASSEMBLY** serial number **MUST** be recorded prior to reinstallation to track the airbag assembly to the vehicle.

VIII. FRONT PASSENGER AIRBAG REINSTALLATION

1. INSTALL A NEW INFLATOR

STOP

Make sure to follow the installation procedure carefully as the instrument panel wire connector cannot be disconnected once connected.

- a) Insert a **NEW** inflator to the center of the airbag case with the correct orientation as shown in the illustration.

STOP

- Make sure that the passenger airbag inflator is oriented correctly as shown in the illustration, not upside down.
- If the passenger airbag inflator is upside down, it will not be able to be fully inserted.

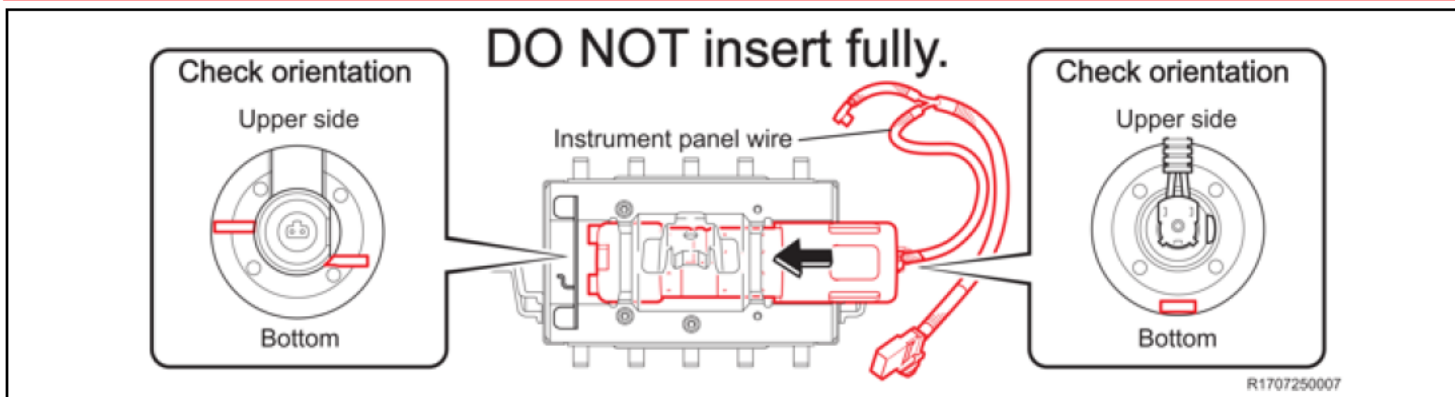

- b) Connect the airbag connector to the instrument panel passenger airbag assembly and then push in the airbag connector lock as shown in the illustration.

STOP

- Make sure to correctly align the connectors before connecting them.
- Make sure that the airbag connector is securely connected.

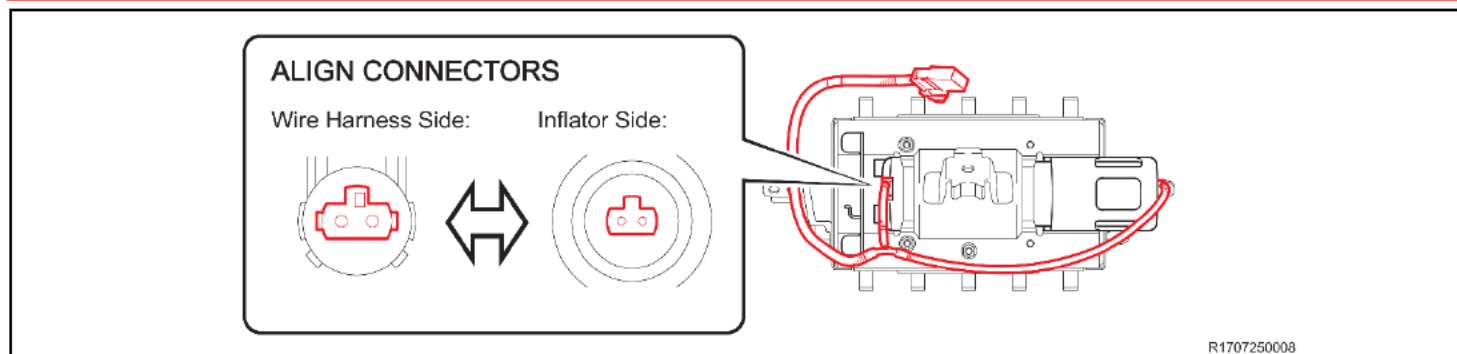

c) Insert the inflator fully as shown in the illustration.

STOP

DO NOT pinch instrument panel wire.

OK

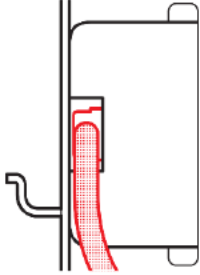

NG

DO NOT pinch the wire

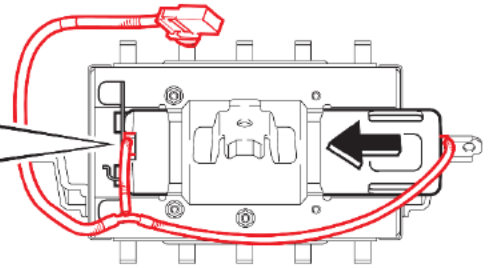
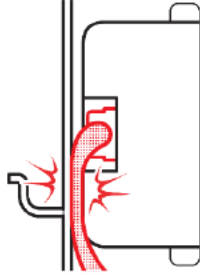

R170725009

d) Insert the inflator with the correct orientation as shown in the illustration.

STOP

- Make sure that the inflator is oriented correctly as shown in the illustration, not upside down.
- If the passenger airbag inflator is upside down, it will not be able to be fully inserted.

Check orientation

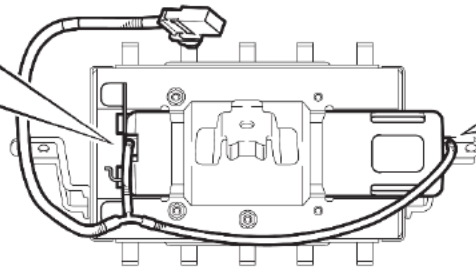
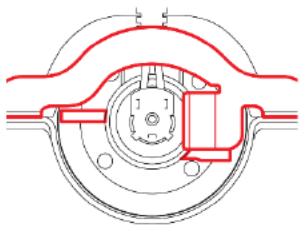

Check orientation

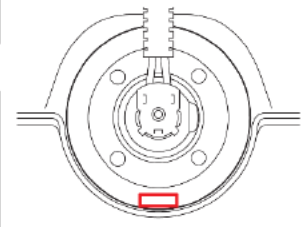

R170725010

Install temporarily
by hand.

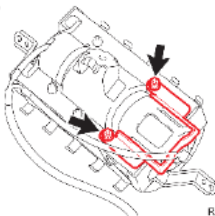

R170725011

e) Temporarily install a **NEW** plate and airbag inflator with the 2 **NEW** self-locking nuts.

Install temporarily
by hand.

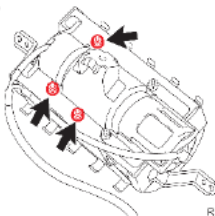

R170725012

- f) Remove the 3 remaining old self-locking nuts and install temporarily 3 **NEW** self-locking nuts by hand.
- g) Store the removed self-locking nut in a replacement part box or the like.

h) Push the inflator and plate to towards the position determining plate to eliminate any gap.



If any gap exists, the aligned flats may move apart, resulting in failure in normal deployment of the airbag.

i) Tighten 5 nuts evenly in several increments in the order shown in the illustration using a socket driver while pushing the inflator and plate. (You will encounter some resistance during tightening because these nuts are self-locking nuts.)

Torque: 3.9 N*m (40 kgf*cm, 35 in.*lbf)



The tightening torque is low (3.9 N·m). Use of an air ratchet wrench or tightening strongly with a T-handle wrench or a ratchet handle may cause deformation of the stud bolt.

OK

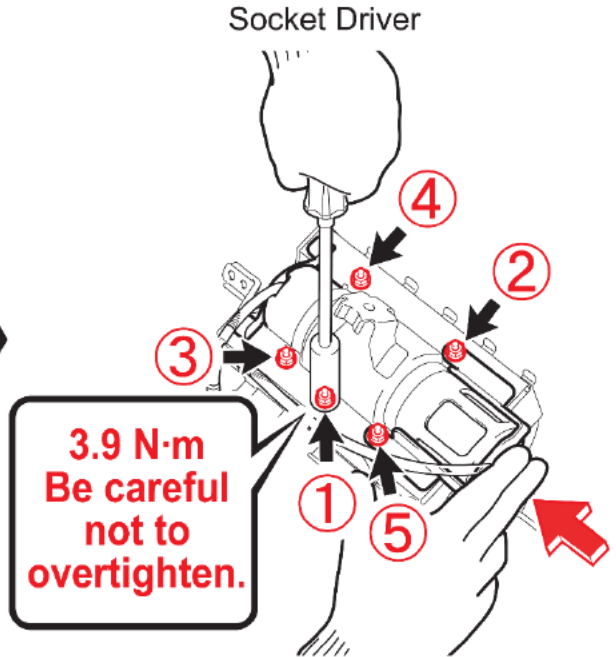
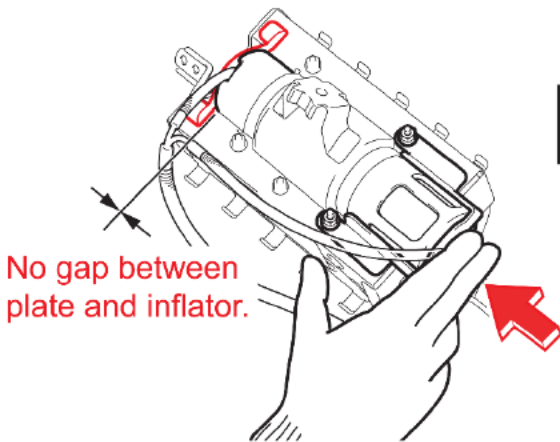

NG

NG

NG

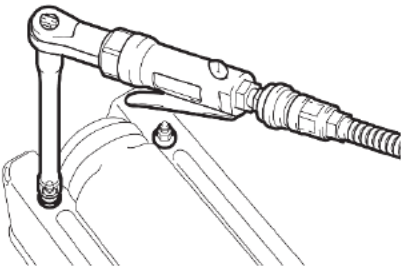

Too Tight!

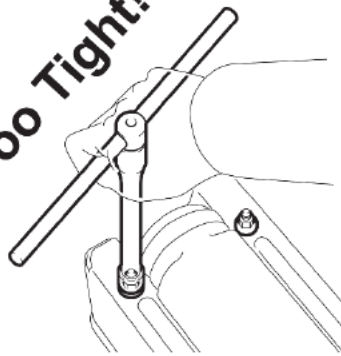

Too Tight!

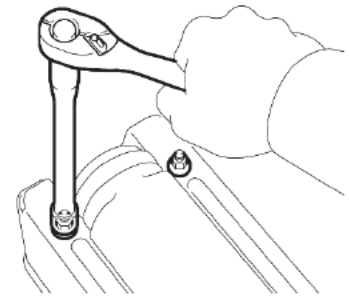

These tools cause overtightening !

R1707250013

2. INTERMEDIATE INSPECTION

- a) Check that the inflator and the 5 self-locking nuts, instrument panel wire are replaced.
- b) Check that positions of the inflator and the position determining plate are correct.
(There should be no gap.)

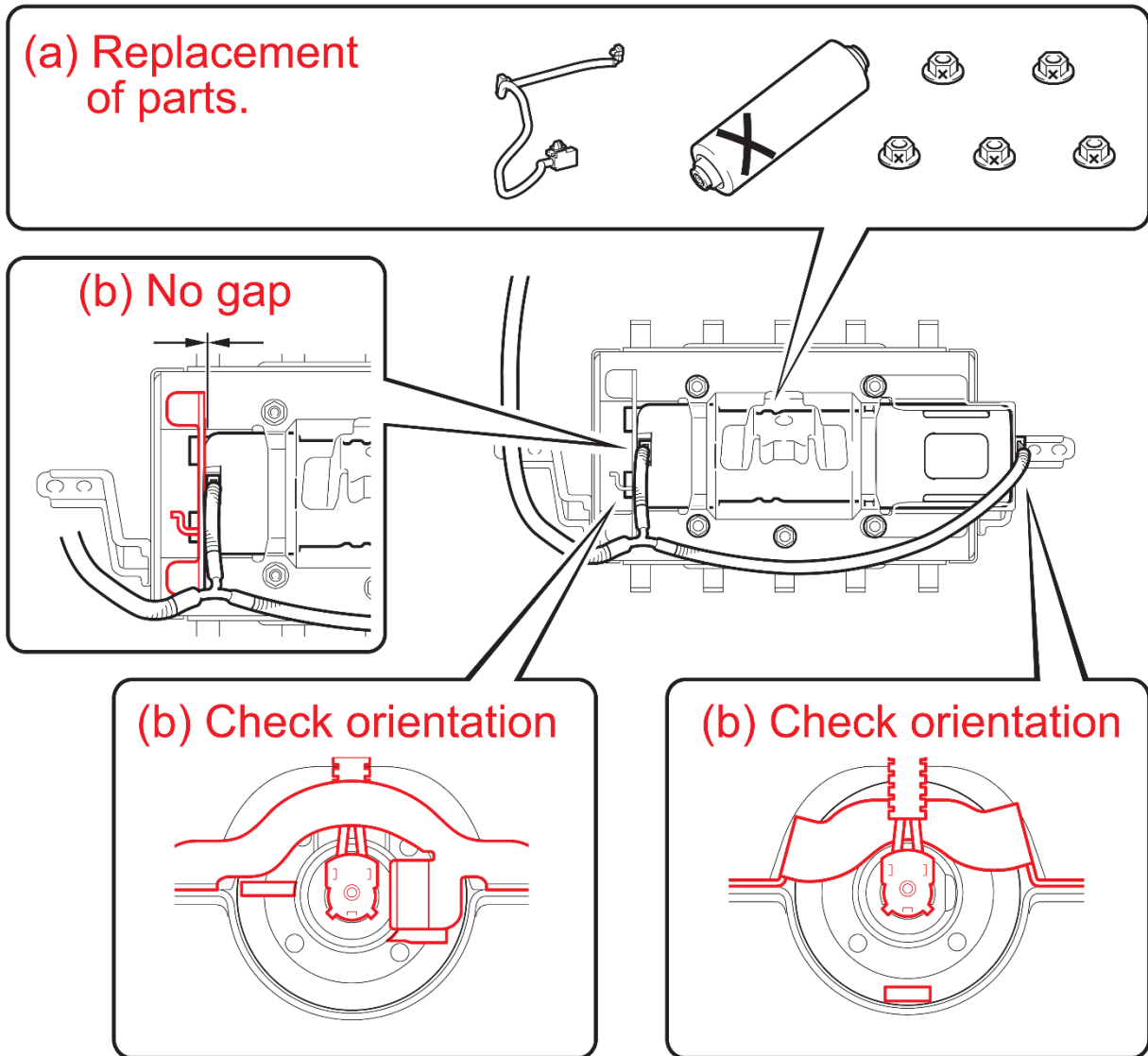

R1707250014

1. REINSTALL THE AIRBAG MODULE

- a) Refer to TIS for instructions on airbag installation:

[2008 MY](#) [2009 MY](#) [2010 MY](#) [2011 MY](#) [2012 MY](#) [2013 MY](#)

2. RECONNECT THE NEGATIVE BATTERY CABLE

- a) Reconnect the negative battery cable.
- b) Perform any needed system initializations.

3. PREFORM ANY NEEDED VEHICLE INITIALIZATIONS

4. PERFORM A HEALTH CHECK AND DIAGNOSTIC REPORT

◀ VERIFY REPAIR QUALITY ▶

- Confirm all precautions are followed to ensure safety during the repair
- Confirm the entire serial number checker application is completed and the warranty authorization # is recorded on **EVERY** vehicle
- Confirm the old inflator is handled safely and given to the appropriate parts professional for shipment

If you have any questions regarding this update, please contact your regional representative.

IX APPENDIX

A. CAMPAIGN DESIGNATION DECODER

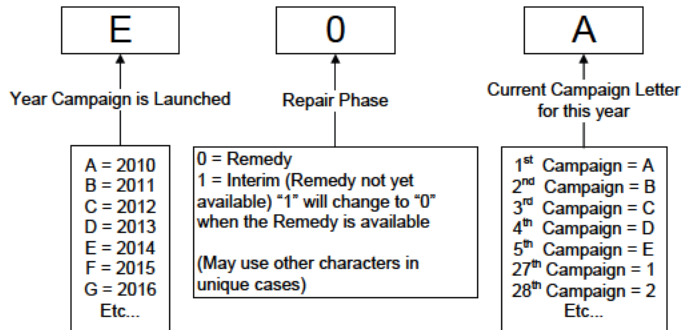

Examples:

A0D = Launched in 2010, Remedy Phase, 4th Campaign Launched in 2010

B1E = Launched in 2011, Interim Phase, 5th Campaign Launched in 2011

C1C = Launched in 2012, Interim Phase, 3rd Campaign Launched in 2012

B. CAMPAIGN PARTS DISPOSAL

ALL inflators that are removed from vehicles under this campaign **MUST** be packaged and shipped back to the inflator manufacturer following the manufacturer's instructions. The instructions can be found in the following locations:

- Attached to the dealer letter
- Included in the parts box