



**SUBJECT: Voluntary Safety Recall Campaign Number 17E-058 Engine Connecting Rod Wrist Pin Bushing Retention**

Department: Service  
Section: Engine  
Model(s): J08  
Model Year(s): 2008  
Effective Date: December 26, 2017  
Form #: Recall bulletin 17E-058  
Rev #: N/A  
Supersedes: N/A

**MODEL AFFECTED:**

<b>YEAR</b>	<b>MODEL</b>	<b>VIN NUMBER</b>	<b>TOTAL</b>
2008 MY	UD1800		1

**DESCRIPTION:**

There may be improper retention of the wrist pin bushing in the connecting rod, which can potentially result in the wrist pin bushing shifting.

As a remedy the engine connecting rods will be inspected. Suspect connecting rods will be replaced as needed.

The owner of the involved vehicle has been notified and instructed to call 336.291.5237 to schedule an appointment with an authorized UD Trucks dealer to have this Safety Recall performed at no charge.

**ADMINISTRATION / DEALER RESPONSIBILITY:**

Dealer is requested to proceed immediately to make the necessary repair to the affected vehicle.

**SERVICE INFORMATION:**

*Before servicing the vehicle, read the entire set of instructions first. Observe the following safety precautions to prevent personal injury, damage to property, or both:*

- Park the vehicle on a flat surface, place the transmission in NEUTRAL, set the parking brake and chock the rear wheels.
- Allow the engine to cool.

**SERVICE PROCEDURES:**

Use a scope to check the engraved mark of the connecting rod or the connecting rod cap and confirm that vehicle is involved in a recall.

- \* The connecting rods used for one engine are from the same lot and not mixed. Thus, confirmation of one connecting rod's grave mark is enough to judge if the vehicle is for the recall or not.

## 1. Involved Vehicle

Medium size truck equipped with J08E engine

Involved engine	Involved VIN
J08 - 013	JNAMA

## 2. Outline of repair work

1) Use a scope to check the engraved mark of the connecting rod or the connecting rod cap and confirm that a vehicle is involved in a recall.

- \* The connecting rods used for one unit of engine should be from the same lot and not mixed. Thus, confirmation of one connecting rod's grave mark is enough to judge if the vehicle is for the recall or not.

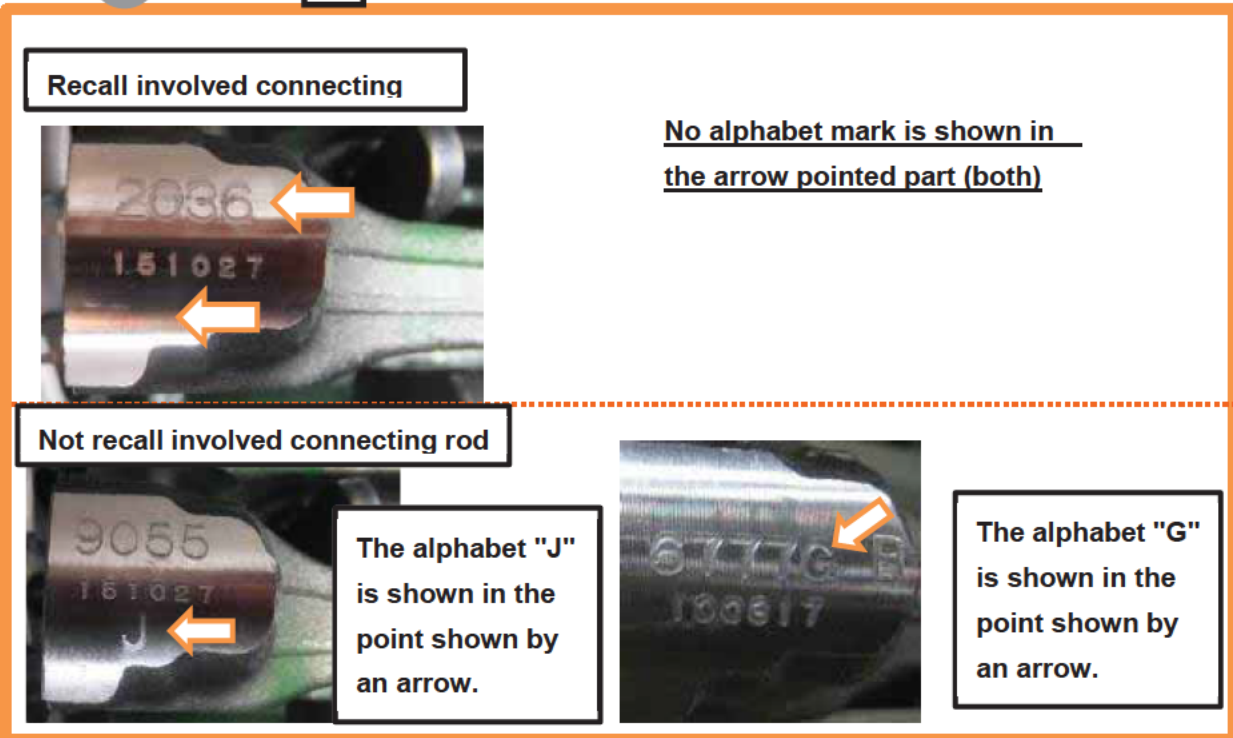
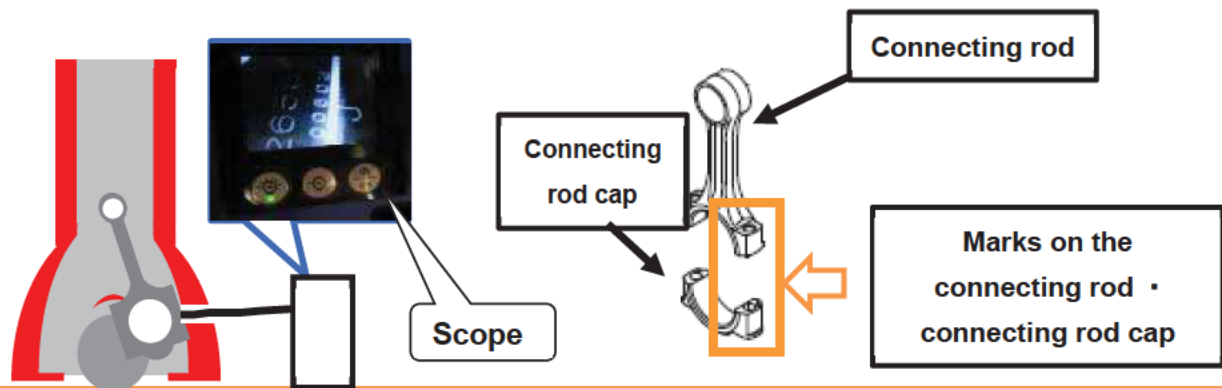

2) When the inspection result of "1.work flow chart is "Replace the connecting rod",

disassemble the engine assemble and replace all connecting rods with the modified parts.

\* For details, refer to the Service Manual Section " Engine Mechanical Overhaul "

3) Outline of the work procedures is shown below.

- (1)Preparation before engine disassembling
- (2)Removal of hose, pipe etc. on the upper side of the engine
- (3)Removal of harness, hoses (intake·fuel system) , pipes, etc.
- (4)Removal of hoses, pipes of exhaust system (turbo charger), etc.
- (5)Removal of cylinder head
- (6)Removal of oil pan and oil strainer
- (7)Removal of piston, connecting rod

Replace the defected connecting rods with the modified connecting rods.

- (8)Assembling of piston, connecting rod
- (9)Assembling of cylinder head
- (10) Assembling of cam shaft, rocker arm
- (11) Assembling of oil pan and oil strainer
- (12) Assembling of hose, pipe etc. for the exhaust system (turbo charger)
- (13) Assembling of harness, hose of intake and fuel system, pipe etc.
- (14) Assembling of hose, pipe etc. on the upper surface of engine
- (15) Assembling of air cleaner, splash board, sound insulation boar
- (16) Injection of engine oil and coolant water

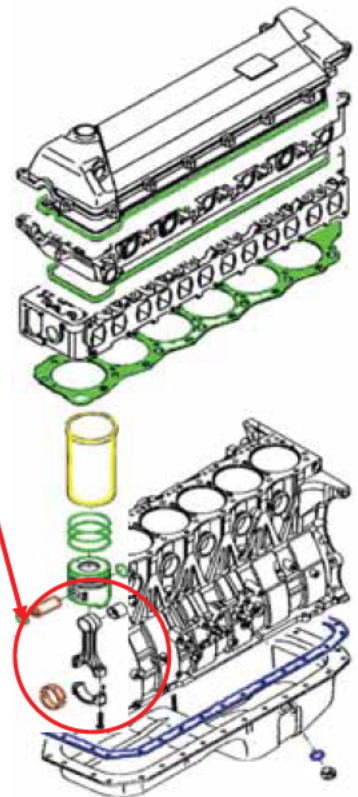

### 3. Handling of the removed parts

Dispose of the removed parts according to Federal or Local Regulations.

#### 4. Preparation tools· parts etc.

##### 4-1. The tools·parts for inspection of the recall vehicles Special tools

Appearance	Parts Number	Parts Name	Use	Procurement
	—	Scope	Inspection of connecting rod engraved marks	(local procurement)

##### Parts list

Appearance	Parts Number	Parts Name	Use	Procurement
	SZ430-14003	Washer, Soft (plug gasket for inspection )	Connecting rod inspection	UDNA Parts

##### Parts for connecting rod inspection

No	Kit number/Contents no.	Kit name/Parts name	Unit
-	SZ43014003	washer, soft	1

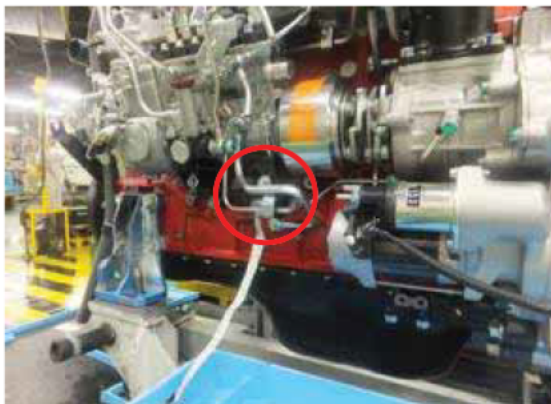
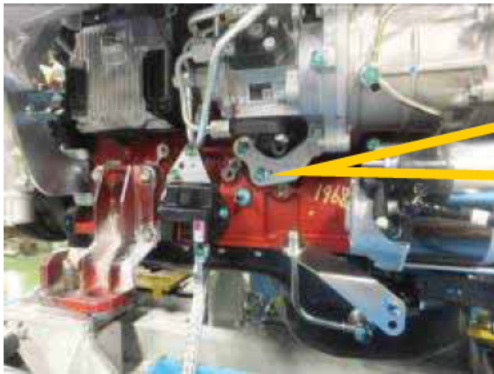

- After inspection, replace the gasket with the new one and reassemble the inspection plug.
- \* In case of the Injection Pump Model, it is a fixing hole of the oil return.





- Insert a scope and confirm the engraved mark .
- If it is difficult, adjust by cranking.  
(It is easily seen around No. 2, 5 of the TDC.)



After the inspection, re-assemble the plug with new gasket.

#### Tightening Torque

30 N · m {300 kgf · cm, 22 lbf · ft}

#### Recall involved connecting

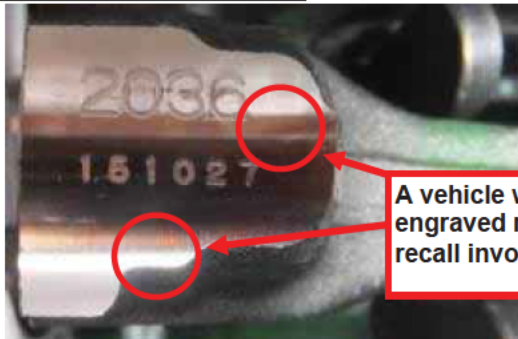

A vehicle with no alphabet engraved mark for both codes is recall involved vehicle.

#### Not recall involved connecting rod

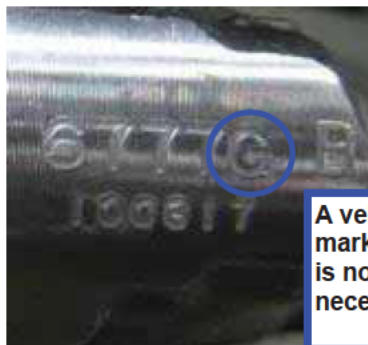

A vehicle with an alphabet engraved mark "J" or "G" is not involved in the recall. It is not necessary to be recalled.

## 1 DRAIN COOLANT, ENGINE OIL & FUEL.

### ① DRAIN COOLANT AND ENGINE OIL.

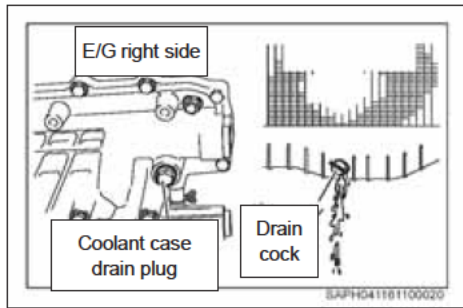

- (1) Drain the coolant water from the drain cock of the radiator and the drain plug of the oil cooler.

#### CAUTION

Drain the coolant water after cooling down to prevent burn injury. Follow the specified waste disposal method, or consider environment when disposing the coolant water.

The coolant can be drained fast by taking off the radiator cap.

The coolant water can be drained without scattering it by connecting an appropriate hose to the oil cooler drain pipe.

Take off the oil filler cap on the engine head cover, and then take off the drain plug of the oil pan before draining the oil.



Take off the oil filler cap on the engine head cover, and then take off the drain plug of the oil pan before draining the oil.

#### CAUTION

Drain with special attention for the prevention of burn injury etc.

### ② DRAIN THE FUEL.

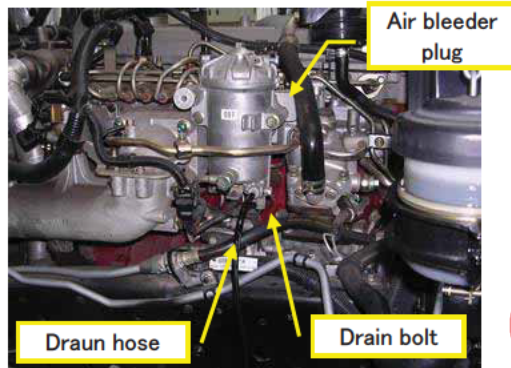

- (1) Fix a drain hose and prepare a container to receive the drained fuel .
- (2) Loosen the air vent bolt of the fuel filter, the drain water bolt and joint bolts of the fuel filter . Then drain the fuel inside of the fuel filter case .

#### CAUTION

When disposing the fuel, follow the regional rules.

## **2 REMOVE THE SPLASH BOARD ON THE FRONT RIGHT.**



- (1) Take off the fixing nut on the frame side of the splash board stay. Then remove the splash board of each stay.



## **3 REMOVE THE AIR CLEANER BODY.**

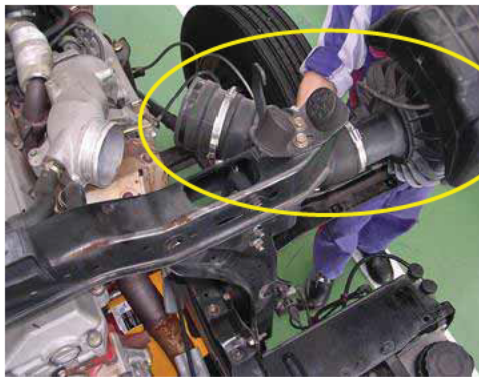

- (1) Remove the air flow sensor out of the intake hose.
- (2) Remove the air cleaner Assy together with the intake hose out of the air cleaner support stay.

**4-2. REMOVE THE HOSE AND PIPE ETC. ON THE UPPER SIDE OF THE ENGINE.**

**1) REMOVE THE AIR COMPRESSOR PIPE & BREATHER HOSE ON THE CYLINDER HEAD.**

**[with/without header tank]**

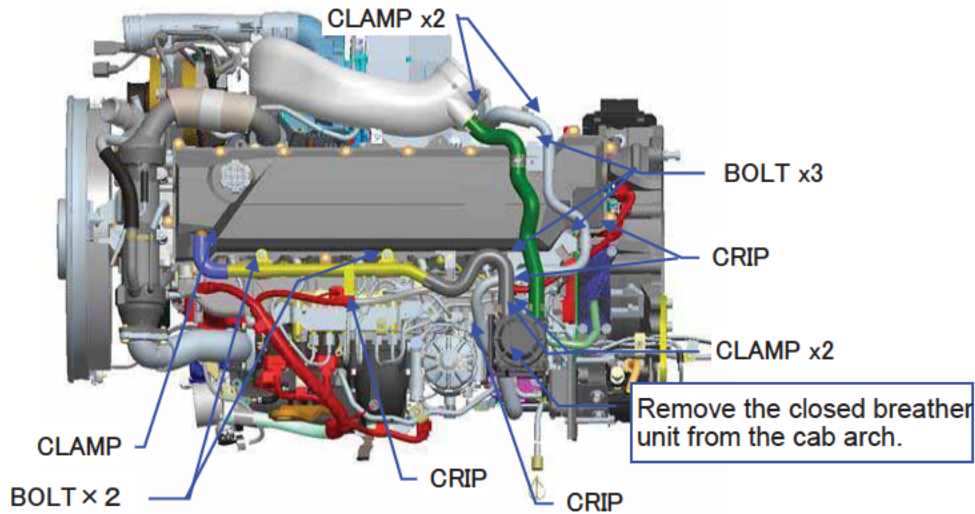

**[Vehicle equipped with tank] Removal of the header tank and the related hose and harness**

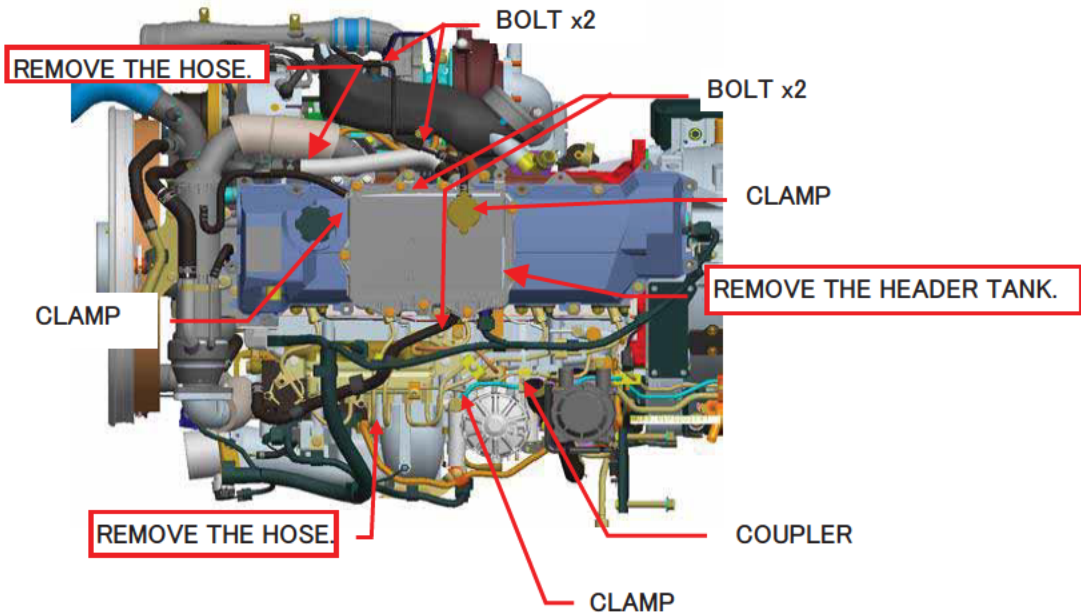

**4-3. REMOVE THE HARNESS & THE HOSES/PIPES OF THE INTAKE & FUEL SYSTEMS.**

**1) REMOVE THE HARNESS ON THE INTAKE SIDE.**

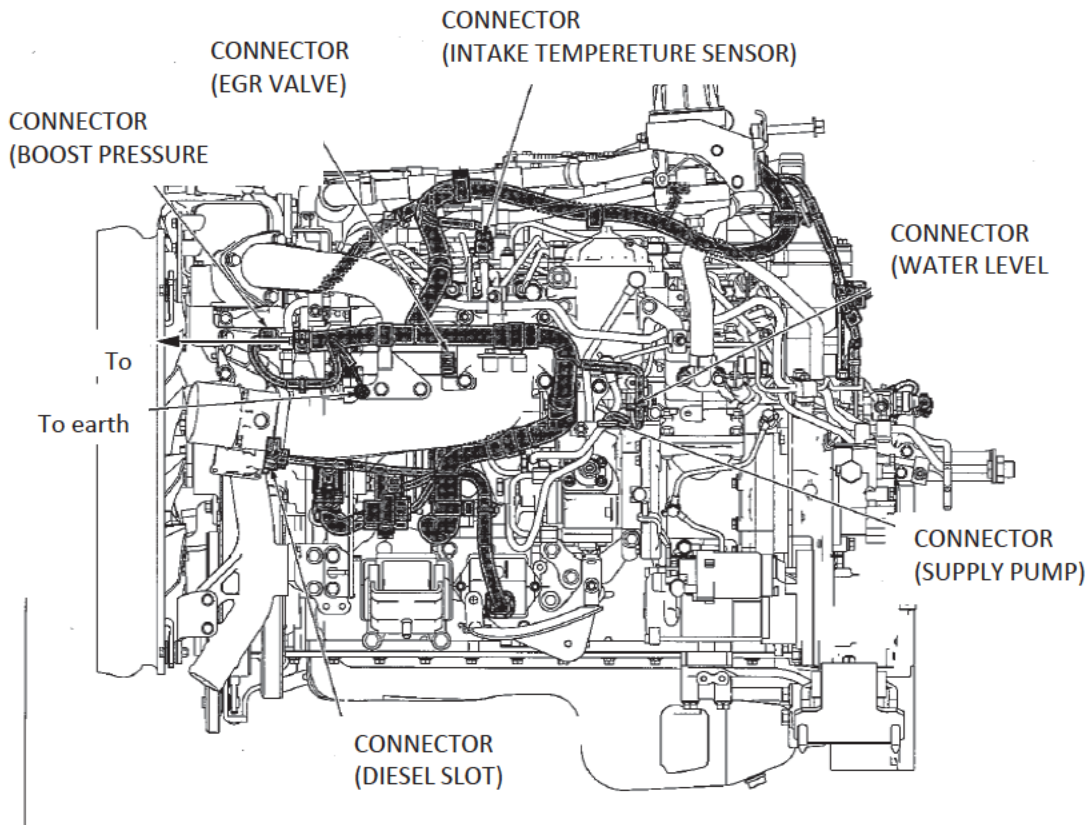

- INJECTOR
- EGR VALVE
- SUPPLY PUMP
- WATER LEVEL SENSOR
- INTAKE TEMPERATURE SENSOR
- BOOST PRESSOR SENSOR

Remove the related couplers.

**Reference**

Since the space around the EGR valve is narrow, it is easier to remove the coupler of the EGR valve when removing the EGR valve and pipe in a unit at the same time.

2) REMOVE THE AIR COMPRESSOR & THE EGR COOLANT PIPE.

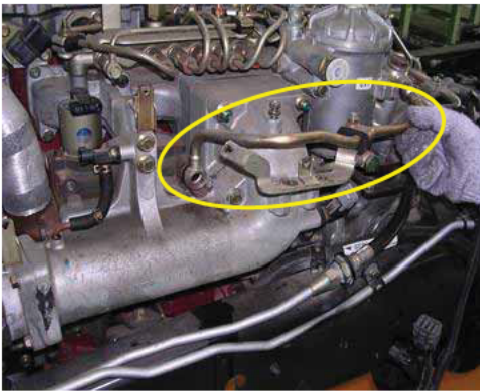

3) REMOVE THE INTAKE PIPE & EGR VALVE & PIPE IN A UNIT.

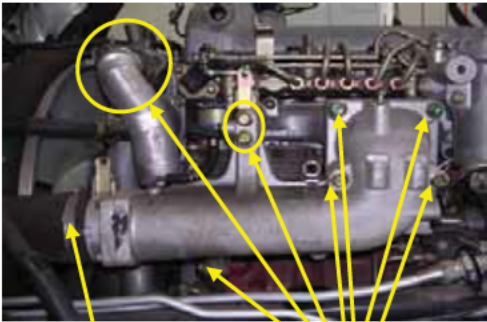

Intercooler Hose

Bolts

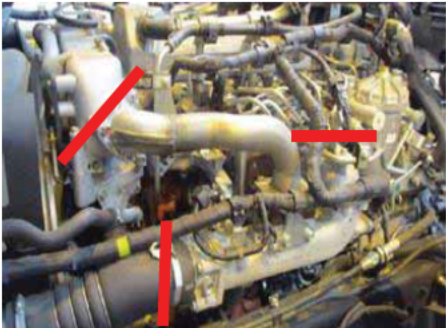

REMOVE



**4) REMOVE THE FUEL PIPE.**

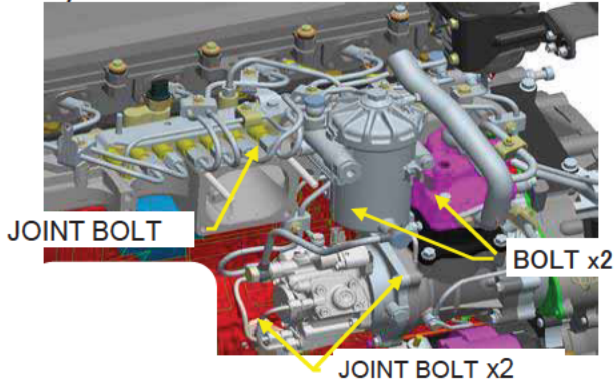

**5) REMOVE THE COMMON RAIL & INJECTION PIPE WITHOUT DISASSEMBLING.**

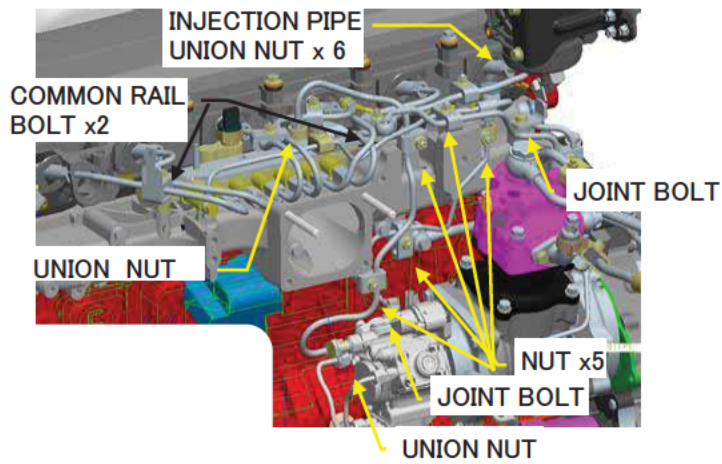

**6) REMOVE THE INJECTOR FUEL RETURN PIPE.**

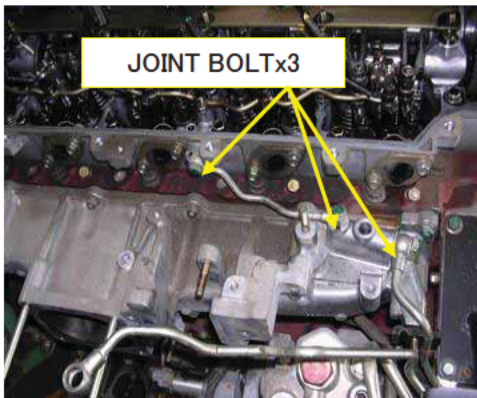

**4-4. Removal of the hose/pipe etc. of the exhaust system (turbocharger)**

**1) REMOVE THE BOOST PIPE & U-TURN PIPE (INTAKE).**

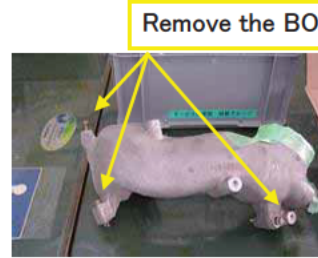
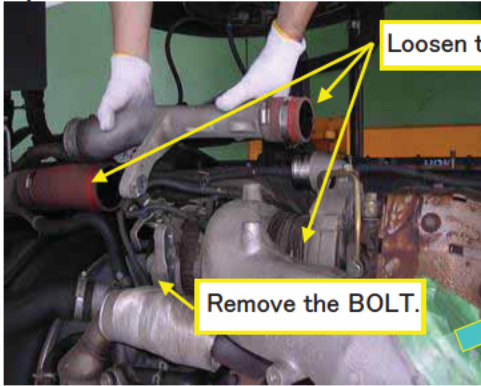

U-turn pipe (Intake)

**2) DETACH THE EXHAUST PIPE & MANIFOLD.**



(1) Remove the four nuts.

Reference

(2) If it does not loosen, heat it with oxygen etc.

### 3) REMOVE THE TURBOCHARGER INSULATOR.

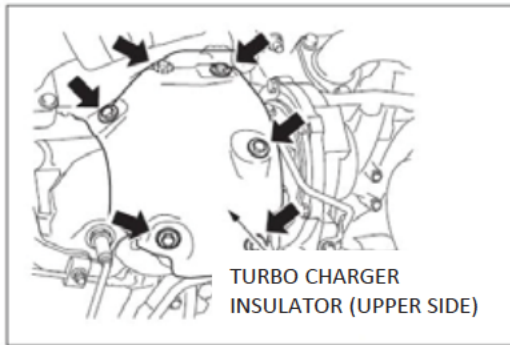

- (1) Remove the turbocharger insulator (upper side).

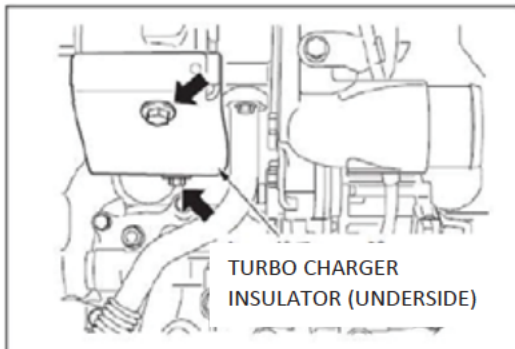

- (2) Remove the turbocharger Insulator (underside).

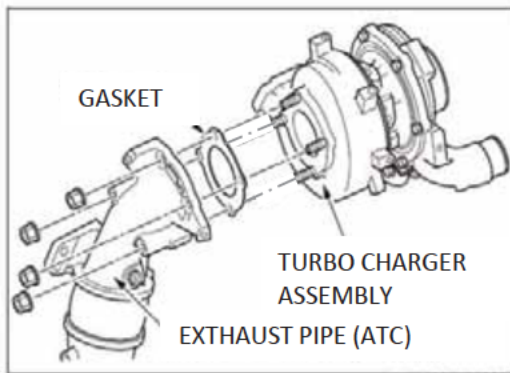

- (3) Remove the four nuts. Remove the exhaust pipe (ATC) and the gasket from the turbocharger Assy.

#### CAUTION

Make sure not to damage the pipe of the fuel additive valve lower side, the harness of the NOx sensor upper stream, and the harness of the exhaust temperature sensor.

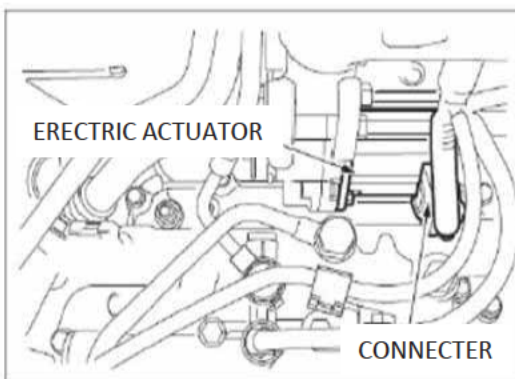

- (4) Remove the connector of the electric actuator.

**4) REMOVE THE COOLANT PIPE & OIL PIPE OF TURBO.**

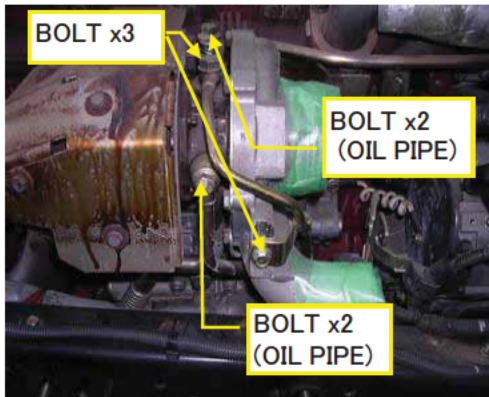

**5) REMOVE THE EGR COOLER.**

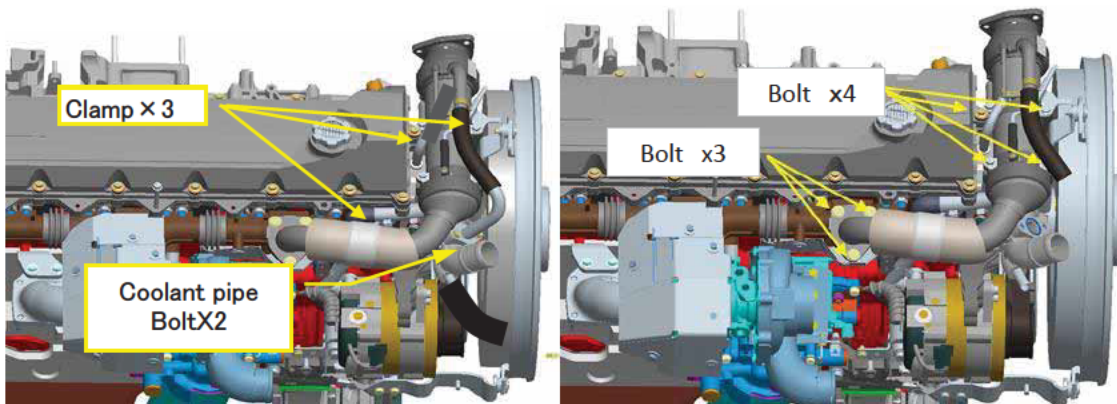

## 1) REMOVE THE HEAD COVER &amp; INJECTOR HARNESS BRACKET.

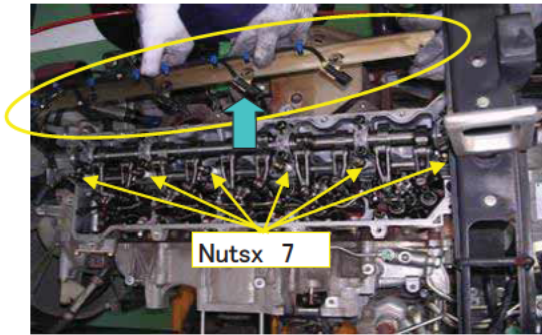

(1) Remove the head cover.

(2) Remove the injector harness Assy.

- a. Disconnect the connector of the injector.
- b. Remove the 7 nuts, disconnect the injector harness Assy with plate.

**CAUTION**

Make sure not to bend the leakage pipe when removing. It is easily bent.

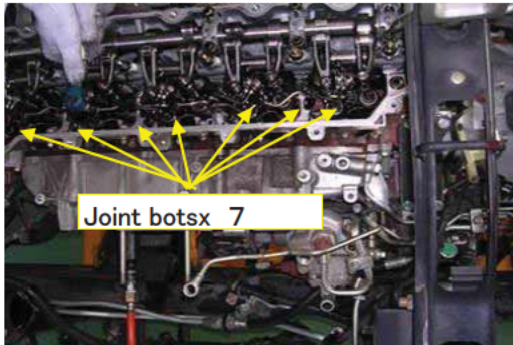

(3) Remove the joint bolts.



(4) Remove the pipe seals.

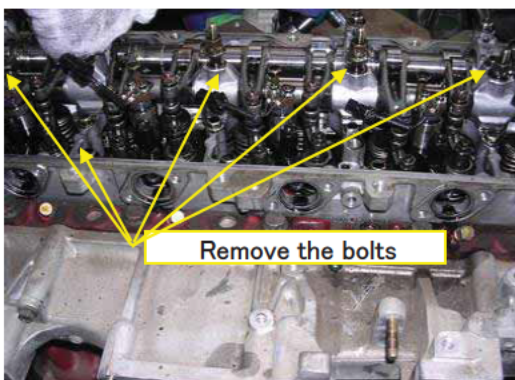

(5) Remove the rocker arm Assy.

- a. Loosen the lock nut at the end of the rocker arm, and turn the adjusting screw counterclockwise completely.
- b. Loosen the injector clamp bolt.

**CAUTION**

If the adjusting screw is removed without winding up, the rocker arms may be bent.

- c. Loosen the rocker arm support bolts in the order shown in the figure.

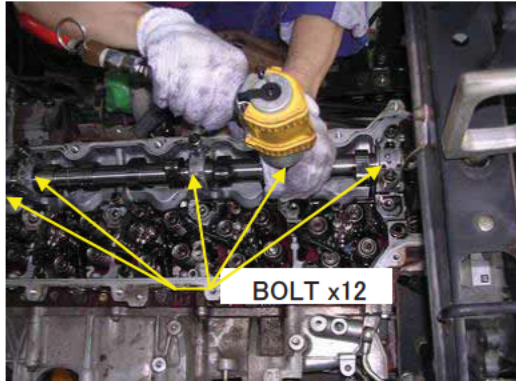
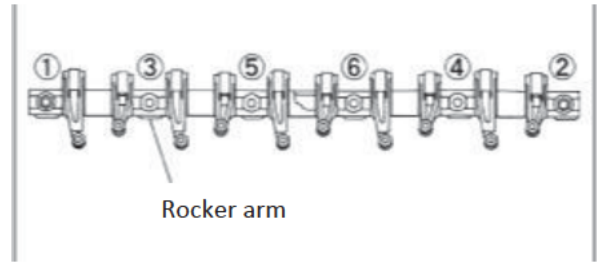
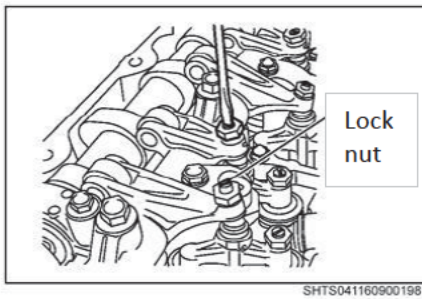

(5) Remove the camshaft.

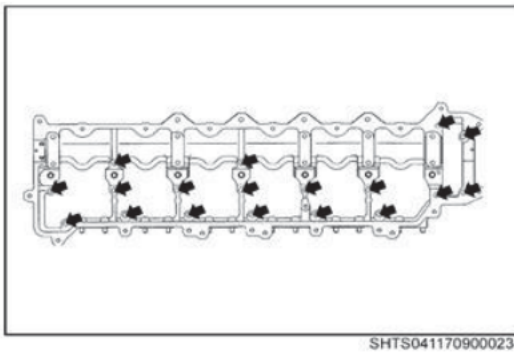

(6) Remove the camshaft housing.

**2) REMOVE THE THERMOSTAT CASE ASSY.**

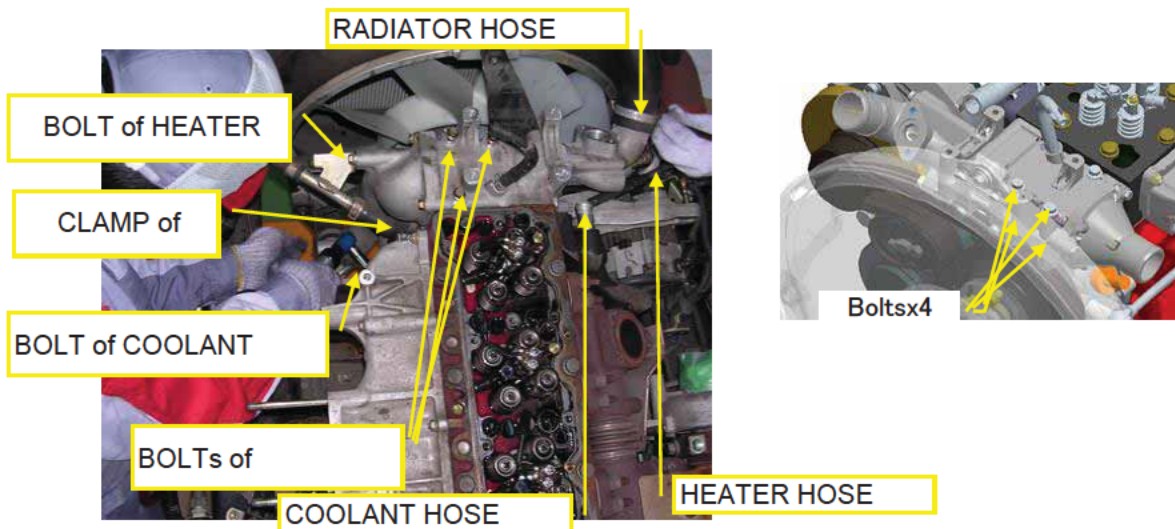

### 3) REMOVE THE CYLINDER HEAD.

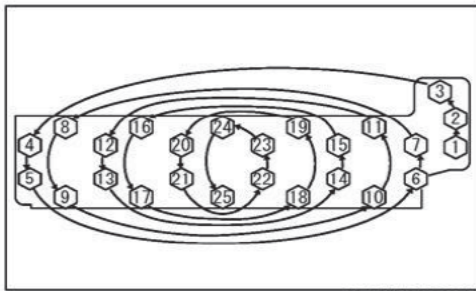

### 4) CLEAN THE CYLINDER HEAD.



- (1) Remove the cylinder head bolts.
  - a. Gradually loosen the bolts three times in the order shown in the figure.

#### CAUTION

If these bolts are not loosened as specified above, the cylinder head may be bent, resulting in improper sealing of combustion gas, water or oil.

- (2) Lift and remove the cylinder head using the special tool and hoist  
SST : Eye bolt (S0943-31070)

#### NOTICE

- Do not damage the cylinder head lower surface or cylinder block upper surface during removal of the cylinder head.
- If it is difficult to lift off the cylinder head, pry with a chisel between the cylinder head and cylinder block.

As gradually lift up the cylinder head by overhead crane, turn the cylinder head 90° below the cab, and move

#### CAUTION

Be careful of balance of the cylinder head when removing.  
Since the clearance between the cab and the body is narrow, make sure not to hit the cylinder block.

When putting the cylinder head on the floor, put the underside of the cylinder head on the woodblocks (15-20cm long).

#### CAUTION

After removing the cylinder head, make sure not to hit the parts such as turbocharger and nozzles protruding from the underside of the cylinder head.

- (1) The cylinder head gasket surface can be cleaned by using the eye bolt only on the timing gear side which was used for lifting up the cylinder head.

- (2) Remove dust, water, oil and, sealant from the top and underside of the cylinder head.



## 1) LIFT UP THE VEHICLE.



Jack-up point (Front) : Frame



Jack-up point (Rear) : Frame

**NOTICE**

Widen the clearance between the front axle and the engine to secure workability.  
 REMOVE THE OIL PAN.

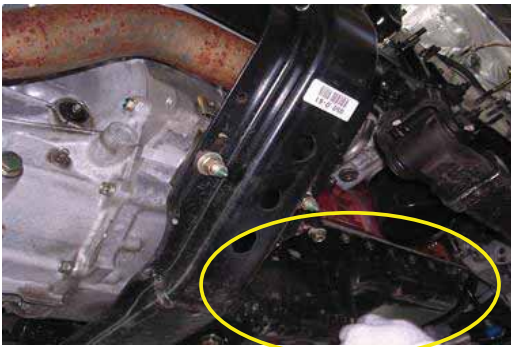

- Remove the bolt of oil pan.

## 3) REMOVE THE OIL STRAINER.

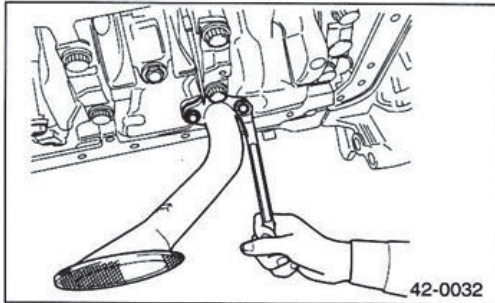

- Remove the bolt of the oil strainer.

## 1) INSTALL THE CYLINDERLINER STOPPERS.

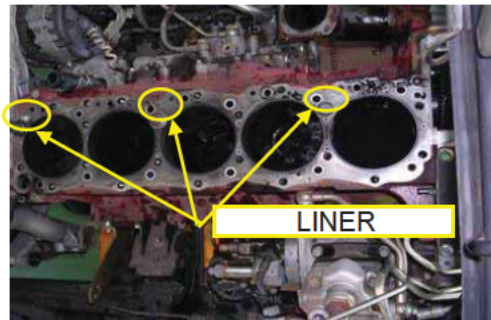

Use the liner stoppers (SST) to prevent the crankshaft from moving up or down with the pistons when turning the crankshaft.

SST: 09218-E9010

## 2) REMOVE THE CONNECTING ROD CAP OF ALL CYLINDERS, &amp; REMOVE THE PISTON WITH CONNECTING ROD.

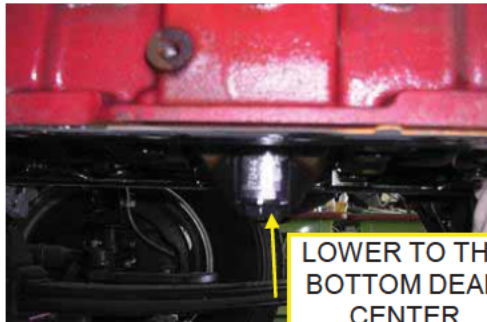

(1) Lower the piston of each cylinder to the bottom dead center. Using a scraper, remove carbon adhering to the upper side of the cylinder liner inner surface along the circumferential direction. Loosen the connecting rod bolts. Remove the connecting rod cap.

**CAUTION**

Do not scratch the lower side of the cylinder liner inner surface which has no carbon adherence.

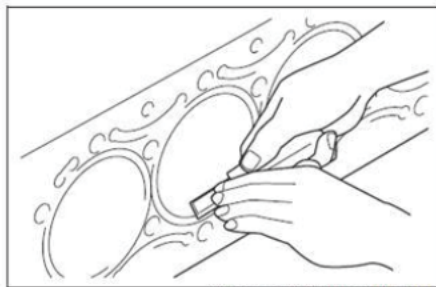

XF4DNV3DHKKH.J04B503QN.JEABIT

Do not remove the bolts at a time since the connecting rod and connecting rod cap are fitted with knock pins. Slightly loosen the bolts. Using a plastic hammer, tap the bolt head to make it easier to separate the cap from the connecting rod and remove the connecting rod from the crankshaft.



(2) After removing the connecting rod cap, do not lift the connecting rod from the crankshaft. Turn the crankshaft 180 degrees as it is. Push the crankshaft up to the top dead center.

(3) Using the piston insertion tool (SST), pull up the piston and the connecting rod.

SST: S1190-H51A3

**CAUTION**

When pulling up the piston, do not rotate the connecting rod to prevent the cooling jet from bending.

If the cooling jet contacts the cylinder, it must be replaced.

Retain the removed piston with the cylinder number specified.



## 1) REPLACE THE CONNECTING ROD.

**\* REPLACEMENT PARTS**

- CONNECTING ROD: 13260-E0100
- CONNECTING ROD BEARING: 13041-E0700
- RETAINER RING: SZ520-37001

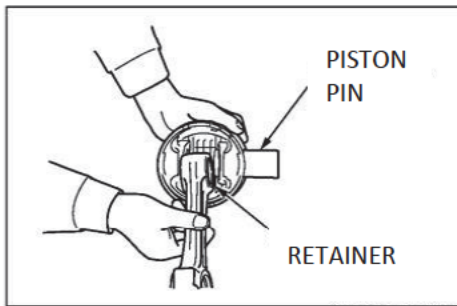

SHTS041160900086

**REMOVE THE PISTON & CONNECTING ROD.**

- (1) Using a snap ring flyer, remove the retainer ring.
- (2) Using a rod-like tool such as brass bar, remove the piston pin to separate the piston pin from the connecting rod.

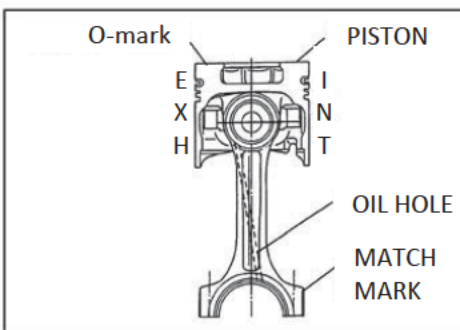

SHTS041160900088

**ASSEMBLE THE PISTON & CONNECTING ROD.**

- (1) Assemble the piston O-mark to be opposite to the connecting rod match mark.
- (2) Using a snap ring flyer, install the new retainer ring.

**CAUTION**

**Make sure that the retainer ring is not loose.**

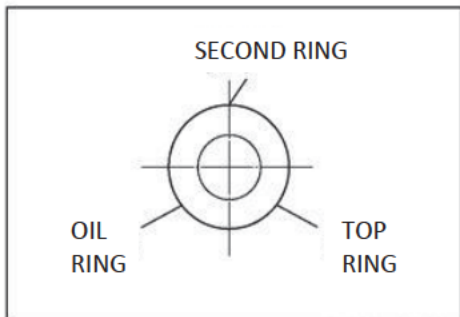

SHTS041160900091

Position the matching points of the piston ring at an even distance as shown in the figure.

## 2) INSTALL THE CONNECTING ROD BEARING.

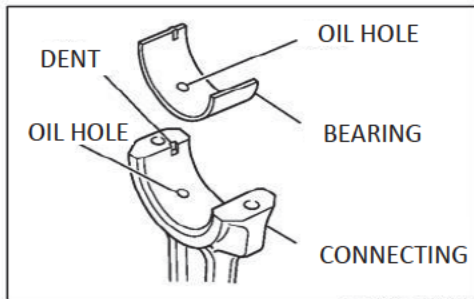

(1) Install the connecting rod bearing in alignment with a dent in the connecting rod.

### CAUTION

Make sure that the oil hole of the bushing and the oil path of the connecting rod are suitably aligned allowing a 6 mm {0.2362 in.} diameter rod to penetrate.

Make sure that dust and foreign particles are not adhered.

## 3) INSTALL THE PISTON.



(1) Apply engine oil to the piston, cylinder liner and connecting rod bearing.

(2) Install the piston targeting the crankshaft of the cylinder as the top dead center.

(3) Make sure that the O-mark on the piston is at the exhaust side.

(4) Compress the piston using the special tool.

**SST: Piston Insertion Jig**

: S1190-H51A3 Piston Insertion Jig

Securely hold the oil ring using the jig when inserting the piston as it is easily

### CAUTION

When installing the piston, be careful that the cooling jet is not struck by the connecting rod.

To prevent engine failure resulting from foreign particles getting caught, make sure to follow the instructions below when installing the piston.

- Completely remove dust and shavings.
- Do not use sandpaper.

## 4) INSTALL THE CONNECTING ROD CAP.

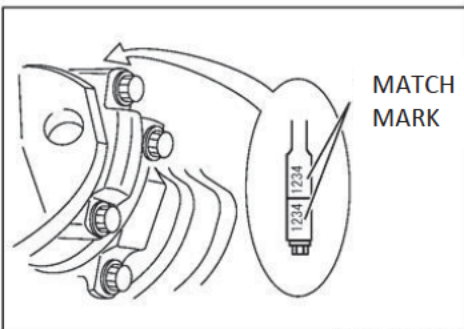

(1) Apply clean engine oil to the bolt thread and the bolt seat surface of the connecting rod cap.

(2) Fit the connecting rod cap and the connecting rod while positioning the match mark on the connecting rod cap with the match mark on the connecting rod.

### CAUTION

Do not change the combination of the match marks on the connecting rod and connecting rod cap.

(3) Tighten the connecting rod bolt to the specified torque.

**Tightening Torque:**

**69 N·m {700 kgf·cm, 50 lbf·ft}**

(4) Mark the bolt heads in the same direction with paint.

(5) Tighten the connecting rod bolt 90° (1/4 turn).

(6) Tighten the connecting rod bolt 45° (1/8 turn).

(7) Make sure that the paint marks face the same direction.

### CAUTION

When adding torque, never untighten the bolts, even if they have been overtightened.

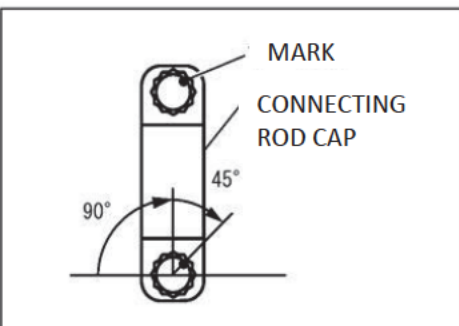

## 1) INSTALL THE CYLINDER HEAD

\* **REPLACEMENT PART**

HEAD GASKET : 11115-E0200

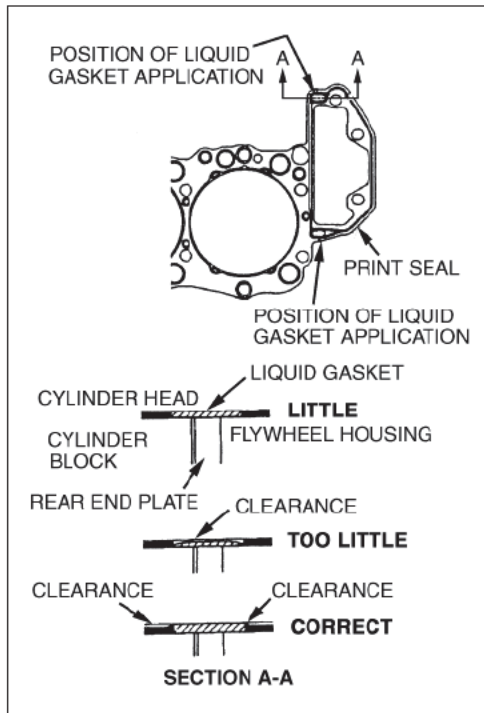
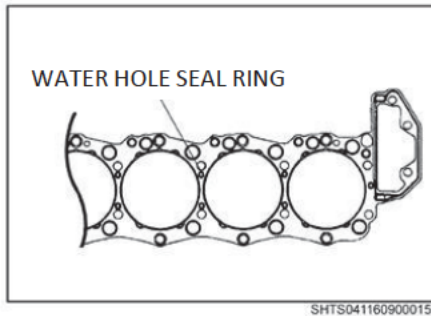
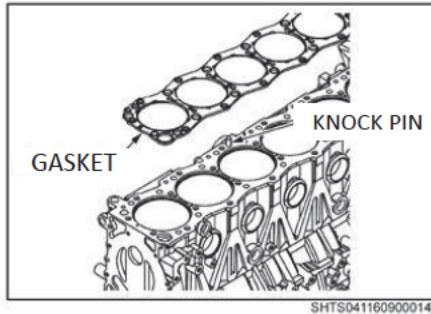

(1) When installing the cylinder head, install the new gasket after removing dirt, moisture and oil on the cylinder head and cylinder block surface.

**CAUTION**

**Clean the cylinder head bolt holes to completely remove dust, water or oil.**

(2) Install the cylinder head gasket on the cylinder block and flywheel housing.

**CAUTION**

**The twelve water hole seal rings between the bores are easily damaged. Do not touch them with your hands or other objects.**

**Make sure that the seal rings are not loose or damaged.**

(3) Fill the hole at the back of the cylinder head gasket with liquid gasket.

**CAUTION**

**Make sure that the liquid gasket surface will be in a convex shape above the head gasket upper surface.**

**Install the cylinder head within 20 minutes after applying the liquid gasket.**

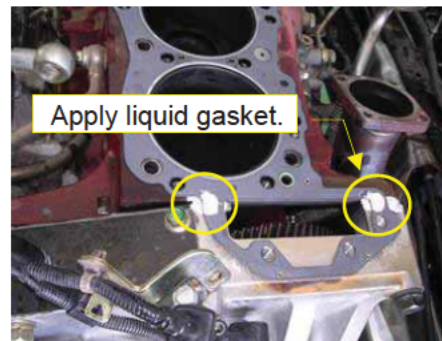

## 2) TIGHTEN THE CYLINDER HEAD BOLTS.

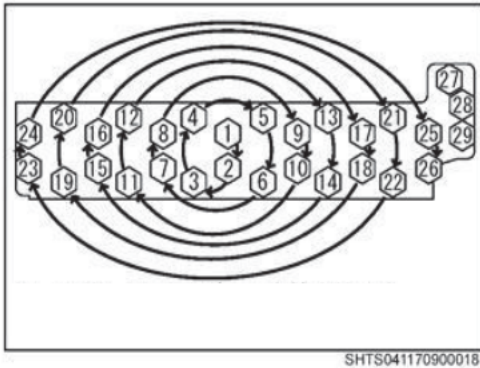

- (1) Apply clean engine oil to the bolt surface and bolt threads of the M12 bolts.
- (2) Tighten No. 1 - No. 26 (M12 bolts) in the order shown in the figure to the specified torque.

**Tightening Torque:**  
**59 N·m {600 kgf·cm, 43 lbf·ft}**

### CAUTION

**J08E: Do not tighten No.27, 28, and 29 (M10 bolts).**

- (3) After tightening all the M12 bolts, retighten them starting at the center towards the outside.

**Tightening Torque:**  
**59 N·m {600 kgf·cm, 43 lbf·ft}**

## 3) TIGHTEN THE CYLINDER HEAD BOLTS BY ANGLE METHOD.



- (4) Mark the M12 bolts with paint to indicate the same directions as shown in the figure.

- (5) Turn No. 1 - No. 26 (M12 bolts) 90° (1/4 turn) in the same order as in (2).

- (6) Retighten them 90° (1/4 turn) as step (5).

- (7) Make sure that all paint marks face the same direction.

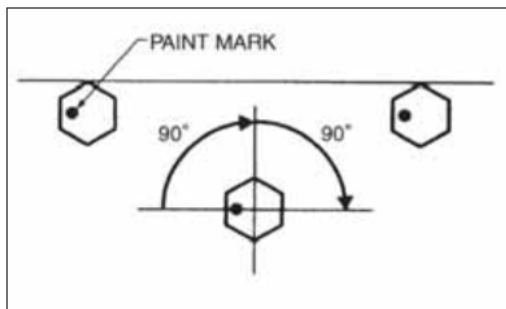

### CAUTION

**When adding torque, never untighten the bolts, even if they have been overtightened.**

#### 4) TIGHTEN THE CYLINDER HEAD BOLTS OF TIMING GEAR.

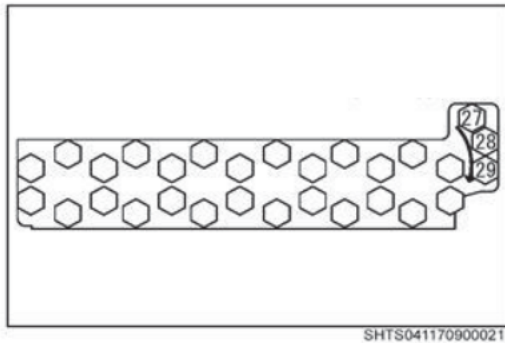

Tighten No.27 - No.29 (M10 bolts) in the order shown in the figure to the specified torque below.

**Tightening Torque:**

**59 N·m {600 kgf·cm, 43 lbf·ft}**

#### CAUTION

If these bolts are not tightened as specified above, the cylinder head may be bent, resulting in improper sealing of combustion gas, water or oil.

#### 5) INSTALL THE THERMOSTAT CASE ASSEMBLY.

**\* REPLACEMENT PART**

WATER PUMP O-RING : SZ301-59006

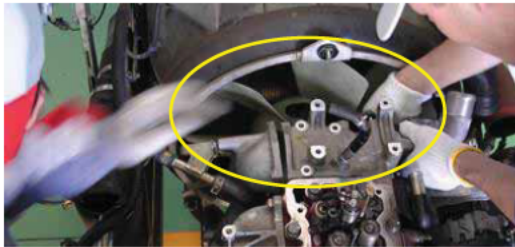

- (1) Remove water or dirt adhering to the thermostat case.
- (2) Apply liquid gasket to the thermostat case.

#### CAUTION

- Apply liquid gasket continuously.
- Apply liquid gasket with 1.5 to 2.5mm in width.
- Install the thermostat case within 20 minutes after applying liquid gasket.

- (3) Install the o-ring into the groove of the coolant pump.

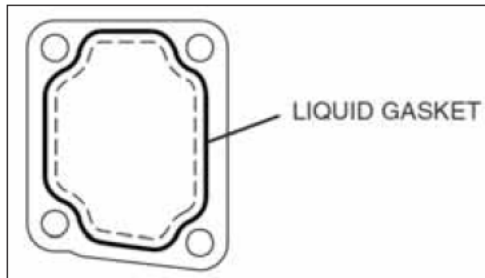

- (4) Temporarily tighten the bolts "1" and bolts "2" in that order, and securely contact the fitting surface.

- (5) Tighten the bolts in numerical order.

**Tightening Torque:**

**36 N·m {370 kgf·cm, 26 lbf·ft}**

**(Bolt 1 & Bolt 2)**

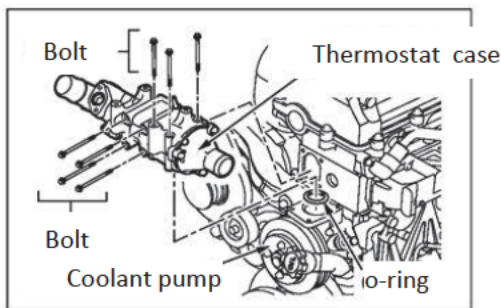
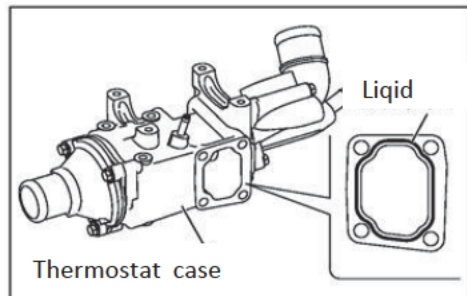

#### CAUTION

Make sure to temporarily tighten the bolts. If not, water leakage may occur.

## 6) INSTALL PARTS AROUND THE THERMOSTAT CASE.

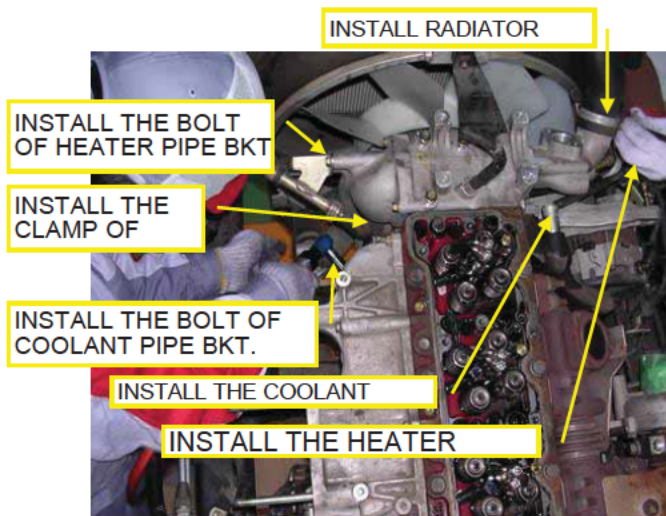

- Heater Pipe Bracket Bolt
  - Coolant Pipe Bracket Bolt
- Tightening Torque :**  
**28.5 N·m {290 kgf·cm, 21 lbf·ft}**

## 4-10. INSTALL THE CAMSHAFT & ROCKER ARM

### 1) INSTALL THE CAMSHAFT HOUSING.

**\* REPLACEMENT PART**

CAMHOUSING GASKET : 11118-E0011

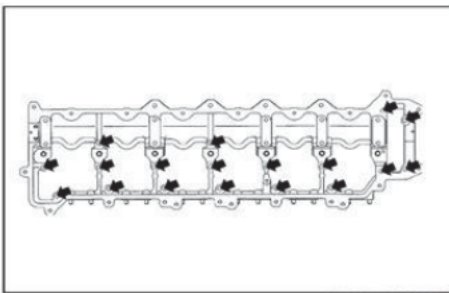

Replace the cam housing gasket. Install the cam housing.

**Tightening Torque :**  
**23 N·m {230 kgf·cm, 17 lbf·ft}**  
Refer to the figure for bolt installation positions.

### 2) INSTALL THE CAMSHAFT.



(1) Align the mark on the flywheel with the flywheel housing pointer to set the No. 1 piston to top dead center of the compression stroke.

(2) Install the camshaft into the cam housing.

- Two drill holes on the camshaft gear should be located at left side and lower drill hole should match with the camshaft housing upper surface.

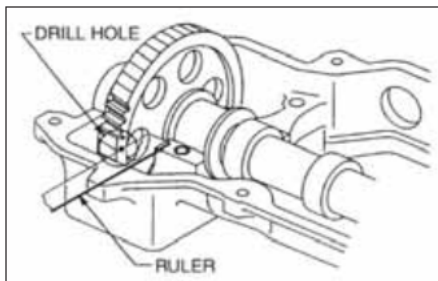

#### **CAUTION**

Put a transparent plastic scale or scale with edge to the top of the camshaft housing and the side of the camshaft housing to make sure that the position of the drill holes for prevention of incorrect assembly are above the scale.

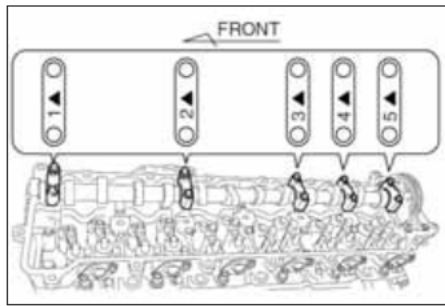

- (3) Install Camshaft bearing caps by fitting the position, in the stamped order of 1, 2, 3, 4 and 5, with each engraved mark headed toward engine front.

**Tightening Torque:**  
**31 N·m {320 kgf·cm, 23 lbf·ft}**

### 3) INSTALL THE ROCKER ARM ASSEMBLY.

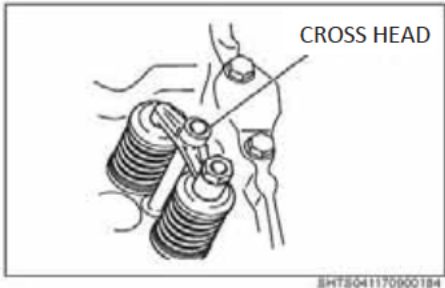

- (1) Make sure that the cross head is on each valve.

**CAUTION** If the cross head is assembled whilst off the valve, the upper seat will be pressed, resulting in a loose valve.

**NOTICE** Check for clicking sounds when moving the cross head from side to side by hand to make sure that the cross head is properly on each valve.

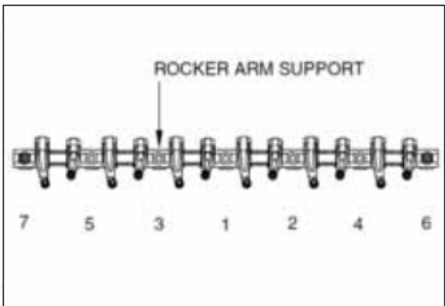

- (2) Make sure that the locker arms are properly installed in the locker arm shaft in the same order as it was installed before.

- (3) Completely wind up the adjusting screw at the end of the rocker arms.

**CAUTION** Apply engine oil to the contact surface of each part before installing.

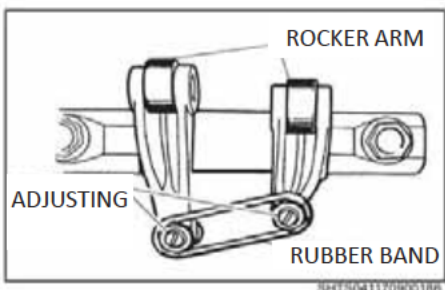

- (4) After installing, apply engine oil to the cam.

**NOTICE** Group the rocker arms into each cylinder number with a rubber band to make it easier to install.

- (5) Install the rocker arms and rocker arm shaft on the camshaft housing. Make sure that the rocker arms are properly installed on the cross head.

#### \*REPLACEMENT PART

ROCKER ARM SUPPORT BOLT : SZ109-10057

Apply engine oil to the seating surface and threads of the new rocker arm support bolts.

Starting at the center, gradually tighten the bolts in numerical order shown in the figure in several times.

**Tightening Torque:**  
**45 N·m {460 kgf·cm, 33 lbf·ft}**

**CAUTION** Do not reuse the rocker arm support bolts. They must be replaced.

**Make sure that the rocker arms move smoothly after installing.**

#### 4) SET UP VALVE CLEARANCE.

Cylinder	Valve		1		2		3		4		5		6	
			IN	EX	IN	EX	IN	EX	IN	EX	IN	EX	IN	EX
With No.1 piston at T.D.C. on compression stroke	Camshaft gear condition			○		○				○	○			
					○		○	○				○	○	○

• Positioning the No.1 or No.6 piston at Top Dead Center of the compression stroke.

#### NOTICE

- #1= View from rear side of camshaft housing
- ○Mark: Possible to check valve clearance
- Firing order: 1-4-2-6-3-5
- T.D.C.: Top Dead Center

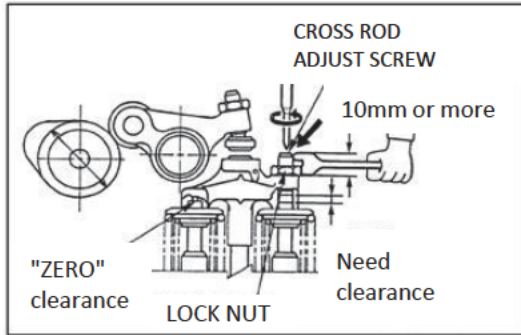

SHTS041160900215

- (1) Loosen the adjusting screw lock nut A, D of the rocker arm and cross head fully.
- (2) The cross head adjusting screw must protrude 10 mm {0.394 in.} or more from the cross head upper face.

#### CAUTION

Unless the adjusting screw is completely loose to the valve stem head, the following adjustments may be adversely affected.

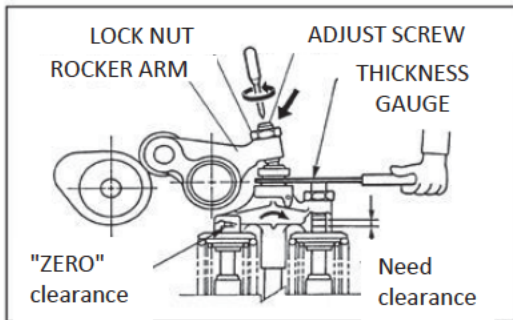

SHTS041160900216

- (3) Insert a feeler gauge of the specified thickness shown below between the rocker arm and the cross head, and adjust the valve clearance with the adjust screw of the rocker arm. After completion of the adjustment, tighten the lock nut A securely with the specified tightening torque.

REFERENCE	IN	0.30mm
(at Normal Tmp)	EXH	0.45mm

**Tightening Torque:**  
25 N·m {255 kgf·cm, 18 lbf·ft}

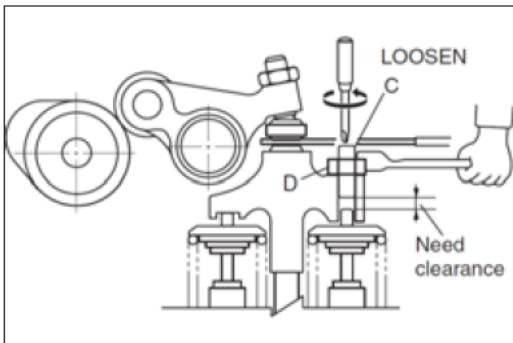

- (4) The condition of inserted feeler gauge, loosen the adjusting screw of the cross head, make sure that the feeler gauge does not feel loose.

#### CAUTION

If the feeling of the feeler gauge becomes loose, repeat steps from (1).

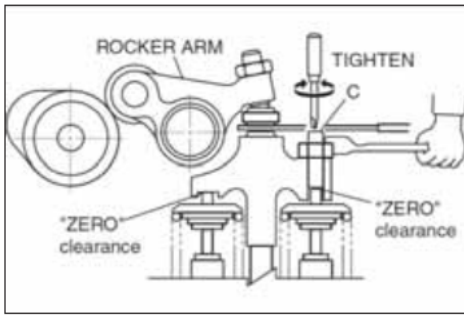

- (5) Tighten the adjusting screw C of the cross head until the feeler gauge does not move.
- (6) While loosening the adjusting screw C of the cross head gradually, adjust the valve clearance. Tighten the lock nut D of the cross head securely with the specified tightening torque when the feeler gauge feels correct.

**Tightening Torque:**  
**25 N·m {255 kgf·cm, 18 lbf·ft}**

**CAUTION**

Do not over loosen the adjusting screw. Over loosening of the adjusting screw C will cause the same condition as in step (3) again. The feeler gauge may feel correct, but there may be excessive clearance between the adjusting screw C of the cross head and the valve stem head E.

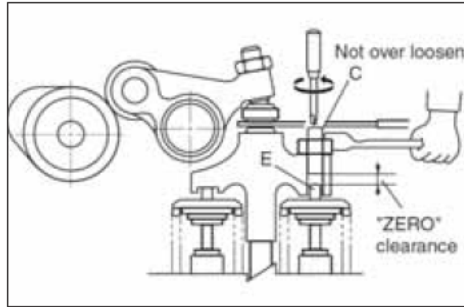

- (7) Install the cover of the flywheel inspection hole.

**Tightening Torque:**  
**28.5 N·m {290 kgf·cm, 21 lbf·ft}**

**5) MOUNTING THE INJECTOR HARNESS & THE LEAKAGE PIPE.**

**\*REPLACEMENT PART**

NOZZLE LEAKAGE PIPE SOFT WASHER : SZ209-08024

Replace all soft washers with the ones having a green identification mark to prevent improper installation.  
 (Washers without the identification mark are also installed in some vehicles.)

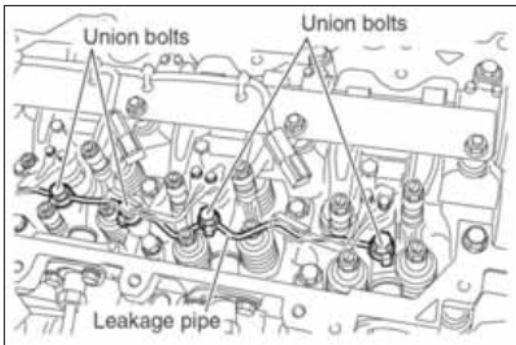
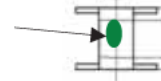

- (1) Mount the injector harness together with the injector bracket with seven bolts that secured them.

**Tightening Torque:**  
**5 N·m {50 kgf·cm, 4 lbf·ft}**

- (2) Connect each connector of the injector harness.

- (3) Replace the gasket with a new one, and mount the leakage pipe on the injector and the camshaft housing with the seven union bolts that fastened them.

**6) MOUNTING THE INJECTION PIPE OIL SEAL.**

**Tightening Torque:**  
**13.5 N·m {138 kgf·cm, 10 lbf·ft}**

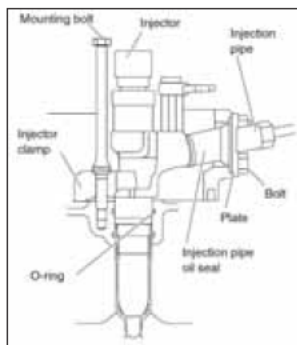

Slip a new injection pipe oil seal on the injector, and mount the plate with the two bolts that secured it.

**Tightening Torque:**  
**28.5 N·m {290 kgf·cm, 21 lbf·ft}**

## 7) INSTALL THE HEAD COVER.

**\*REPLACEMENT PART**

HEAD COVER GASKET : S1121-31880



(1) Remove the liquid gasket from the camshaft housing plugs and camshaft housing completely.

**CAUTION** Do not remove the plug except when there is oil leakage from plug.

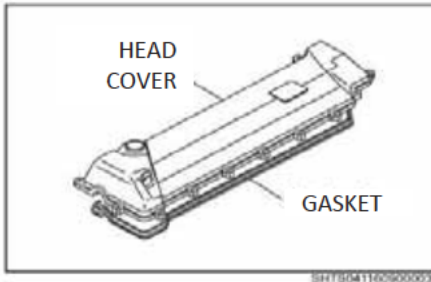

(2) Install the head cover gasket into the gasket groove at the head cover lower surface.

**CAUTION** Make sure that there are no foreign particles (including liquid gasket), or oil on the gasket grooves of the head cover, gasket or cam housing upper surface nor damage to them.

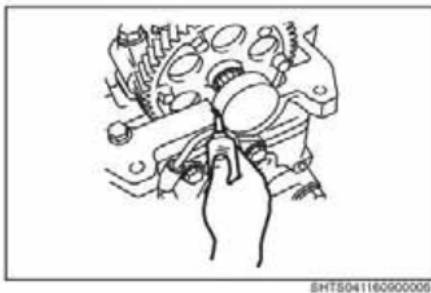

(3) Apply liquid gasket to the plug corner at the front and rear ends of the cam housing before installing the head cover.

**CAUTION**

- Apply liquid gasket with 1.5 to 2.5mm in width.
- Install the head cover within 20 minutes after applying liquid gasket.
- Do not apply liquid gasket to the upper semicircle of the cylindrical plug.

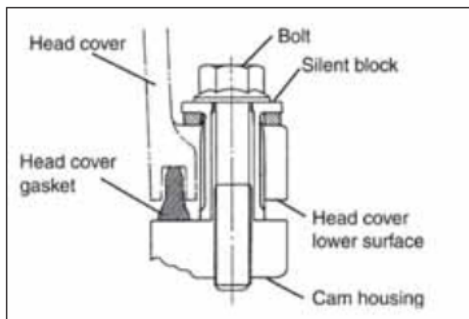

(4) Insert the silent block from the head cover upper surface.

(5) Tighten the bolt through the silent block to the specified torque below and fix the head cover on the cam housing.

**Tightening Torque:**

**28.5 N·m {290 kgf·cm, 21 lbf·ft}**

## 1) MOUNTING THE OIL STRAINER.

**\*REPLACEMENT PART**

OIL STRAINER O-RING : SZ301-29010

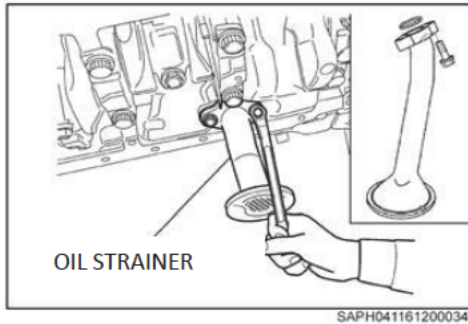

(1) Using a scraper, remove dirt on the mating surface between the cylinder block and the oil pan.

**CAUTION**

- Do not leave dust and shavings inside the oil pan and the cylinder block.
- Do not use sandpaper. Using sandpaper will cause engine failures resulting from foreign particles getting caught.

(2) Make sure that there is no deformation, dust or oil on the mating surface between the cylinder block and the oil pan. After having confirmed, apply liquid gasket (equivalent to ThreeBond TB1207D, silver) to the front and rear ends of the underside of the cylinder block.

(3) Replace the O-ring with a new one. Install the oil strainer.

**Tightening Torque:**

**28.5 N·m {290 kgf·cm, 21 lbf·ft}**

## 2) MOUNTING THE OIL PAN

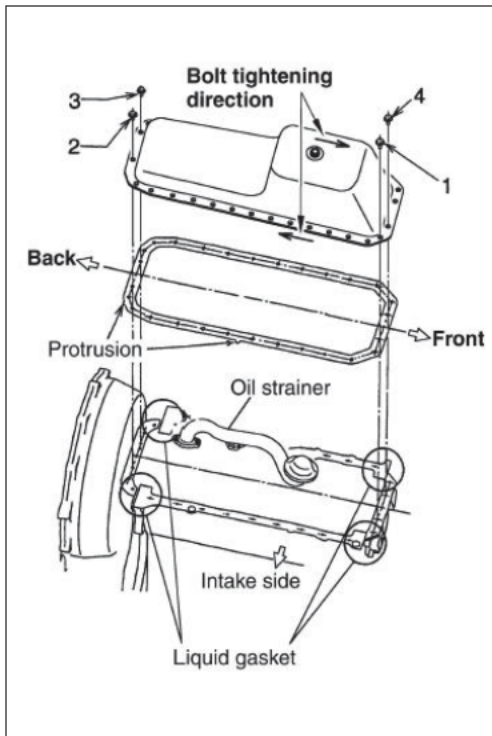
**\*REPLACEMENT PART**

OIL PAN GASKET : 12151-E0071 (J08E)

**\*REPLACEMENT PART**

DRAIN PLUG GASKET SZ430-18009

- (1) Install the gasket so that the protrusion is at the flywheel housing side and the intake side. (the print seal surface is at the cylinder block side)
- (2) Place a guide pin of 70 mm or more in the cylinder block and assemble the oil pan against the guide.
- (3) Tighten oil pan fitting bolts in the order 1 - 2 - 3 - 4 with an impact wrench.

**Tightening Torque:**

**19.6~24.5N·m { 200~250kgf·cm }**

**CAUTION**

- Make sure that the washer is not on the flange.
- Make sure that there is no deformation, impact marks or foreign particles on the cylinder

- (4) Finish tightening the bolts with a torque wrench to the specified torque. Tighten the bolts according to the arrow in the figure.

**Tightening Torque:**

**30 N·m {300kgf·cm, 22lbf·ft}**

## 4-12. ★ ASSEMBLE PIPES & HOSES OF EXHAUST SYSTEM.

### 1) MOUNT THE EGR COOLER.

#### \*REPLACEMENT PART

EGR PIPE GASKET : S1710-41990

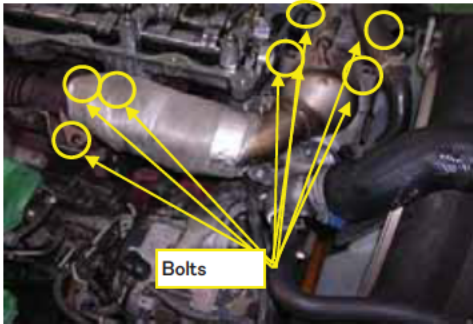

(1) Install the EGR cooler with bolts.

#### Tightening Torque:

37 N·m {380 kgf·cm, 27 lbf·ft}

(2) Install the new gaskets between the exhaust manifold and the EGR pipe with bolts and nuts.

#### Tightening Torque:

68.5 N·m {700 kgf·cm, 50 lbf·ft}  
(BOLT & NUT)

#### \*REPLACEMENT PART

COOLANT PIPE O-RING : SN732-00213

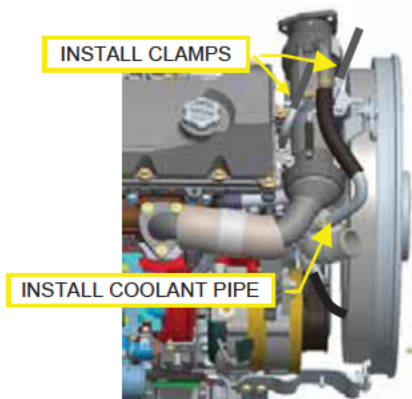

(1) Install the clamps to the EGR cooler coolant hose.

(2) Replace the O-ring of the EGR cooler coolant pipe with a new one.

#### Tightening Torque:

28.5 N·m {290 kgf·cm, 21 lbf·ft}

## 2) MOUNT THE COOLANT PIPE & OIL PIPE OF TURBO.

### \*REPLACEMENT PARTS

OIL PIPE SOFT WASHER (In)	: SL722-01210 x 2
OIL PIPE SOFT WASHER (In)	: SL722-01415 x 2
OIL PIPE GASKET(Out)	: S2413-51121 x 2
COOLANT PIPE SOFT WASHER (In & Out)	: SZ430-14003 x 8

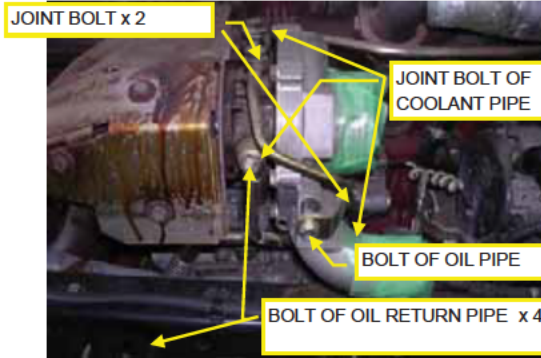

Replace the **soft washers** of the joint bolts securing each pipe with new ones.

**Tightening Torque:**  
25 N·m {255 kgf·cm, 18 lbf·ft}

Replace the gasket of the oil return pipe with a **new one**. Tighten the bolts.

**Tightening Torque:**  
28.5 N·m {290 kgf·cm, 21 lbf·ft}

### CAUTION

Clean and inspect the pipes for signs of dust or foreign particles inside the pipes or deformation.

## 3) MOUNT THE EXHAUST PIPE.

### \*REPLACEMENT PARTS

EXHAUST PIPE GASKET	: S1710-41580	1
NUT	: SZ178-10007	4

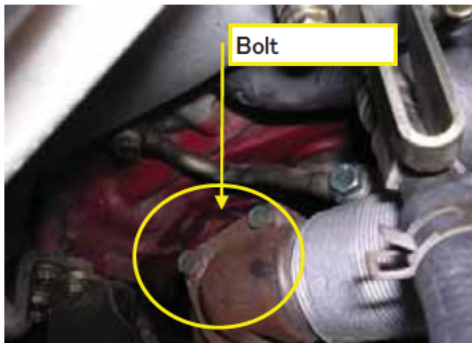

Replace the gasket and four nuts with new ones. Install the exhaust pipe (ATC) to the turbocharger Assy.

**Tightening Torque:**  
68.5 N·m {700 kgf·cm, 50 lbf·ft}

### CAUTION

Make sure that the gasket and the nuts are replaced to prevent exhaust gas leakage.

## 3) MOUNT THE TURBO CHARGER INSULATOR.

Install the turbocharger insulator to the turbocharger Assy with eight bolts.

**Tightening Torque:**  
25 N·m {255 kgf·cm, 18 lbf·ft}

#### 4) INSTALL THE INTAKE PIPE & THE BOOST PIPE.

##### \*REPLACEMENT PARTS

CLAMP (INTAKE SIDE)	: SZ460-11006
CLAMP (BOOST SIDE)	: SZ460-70006
HOSE	: SZ920-33C60

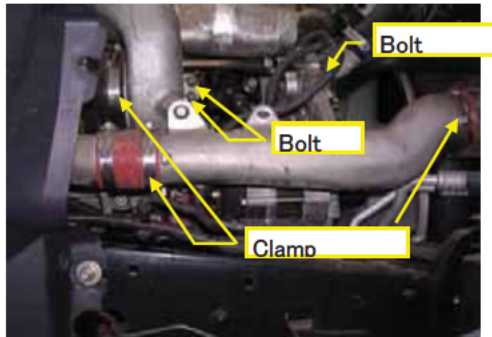

Fit the hose and the intake pipe to the turbocharger inlet port. Install and tighten the bolts to fix the hose and the intake pipe to the block side. Install and tighten the clamps.

**Tightening Torque (BOLT):**  
28.5 N·m {290 kgf·cm, 21 lbf·ft}  
**Tightening Torque (CLAMP):**  
6 N·m {60 kgf·cm, 4 lbf·ft}

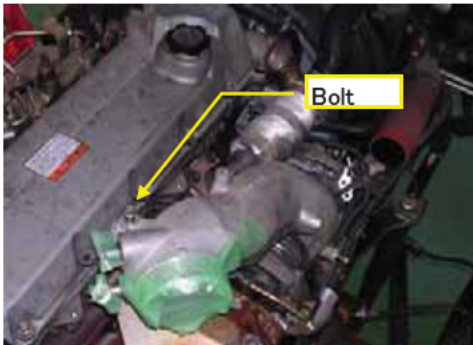

Replace the turbocharger secondary intake hose with a new one. Insert the boost pipe between the turbocharger secondary intake hose and the inter cooler hose. Install the boost pipe to the alternator bracket with the bolt.

**Tightening Torque (BOLT):**  
28.5 N·m {290 kgf·cm, 21 lbf·ft}  
**Tightening Torque (CLAMP):**  
6 N·m {60 kgf·cm, 4 lbf·ft}

#### CAUTION

Make sure that dust or foreign particles are not inside the air intake system.

Do not use sealant to prevent failures such as damage to the air inlet and outlet ports due to clogging or loosening of tightened areas.

Make sure that the clamps are tightened properly to prevent air leakage from joints between the intake pipe and the air hose.

#### 5) MOUNT THE ALTERNATOR HARNESS.



• Mounting the alternator harness.

#### 4-13. ★INSTALL HARNESS, PIPE, AND HOSE OF INTAKE & FUEL SYSTEMS.

##### 1) MOUNT THE FUEL RETURN PIPES.

###### \*REPLACEMENT PARTS

SOFT WASHER : SZ430-08013 x 2  
SOFT WASHER : SZ430-14003 x 2

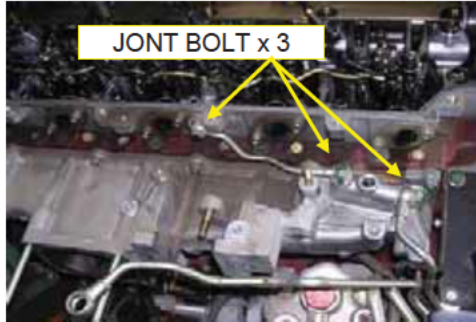

(1) Replace the soft washers of the fuel return pipe with new ones. Install the fuel pipes with the joint bolts.

•CYLINDER HEAD~INTAKE MANIFOLD

###### Tightening Torque:

13 N·m {130 kgf·cm, 10 lbf·ft}

•INTAKE MANIFOLD~CHASSIS

###### Tightening Torque:

25 N·m {255 kgf·cm, 18 lbf·ft}

##### 2) MOUNT THE COMMON RAIL & INJECTION PIPES.

###### \*REPLACEMENT PARTS

SOFT WASHER : SZ430-10011 x 2  
SOFT WASHER : SZ430-14003 x 2

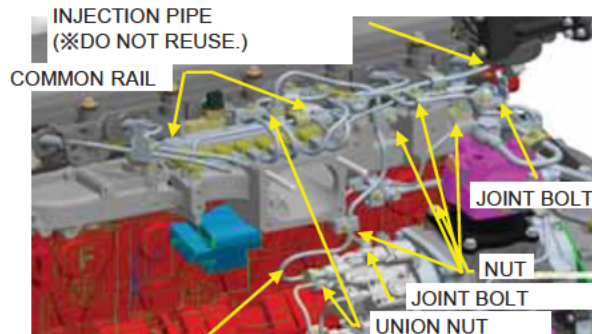

PRESSURE FEEDING PIPE  
(※DO NOT REUSE.)

###### CAUTION

Make sure to replace the injection pipe and the pressure feeding pipe with new ones. If not, fuel leakage may occur.

Install the common rail Assy.

Install the common rail with two bolts.

###### Tightening Torque:

28.5 N·m {290 kgf·cm, 21 lbf·ft}

Replace the injection pipe and the pressure feeding pipe (between the supply pump and the common rail) with new ones, and install them.

Part Name	Part No.
INJECTION PIPE No.1	S2371-12660
INJECTION PIPE No.2	S2371-22630
INJECTION PIPE No.3	S2371-32560
INJECTION PIPE No.4	S2371-42580
INJECTION PIPE No.5	S2371-52390
INJECTION PIPE No.6	S2371-62390

###### Tightening Torque (NUT):

44 N·m {450 kgf·cm, 32.5 lbf·ft}

PRESSURE FEEDING PIPE : S2378-15990  
(SUPPLY PUMP ~ COMMON RAIL)

###### Tightening Torque:

44 N·m {450 kgf·cm, 32.5 lbf·ft}

Tighten the joint bolt of the leakage pipe pump.

###### Tightening Torque:

20 N·m {200 kgf·cm, 15lbf·ft}

### 3) MOUNT THE FUEL FILTER & AIR BLEEDING.

#### \*REPLACEMENT PART

SOFT WASHER : SZ430-14003

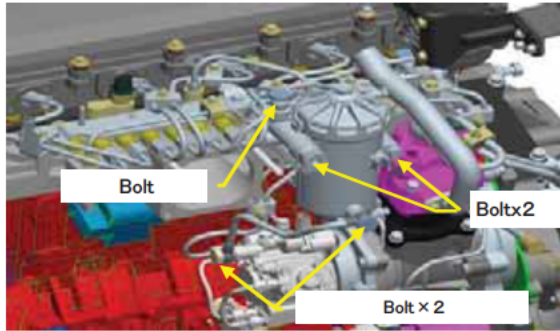

Install the fuel filter assembly to the fuel filter bracket with two bolts.

**Tightening Torque:**

**55 N·m {560 kgf·cm, 41 lbf·ft}**

Connect the fuel pipe.

**Tightening Torque:**

**25 N·m {250 kgf·cm, 18 lbf·ft}**

- (1) Loosen the air bleeder plug.
- (2) Activate the manual priming pump. Bleed air from the fuel system.
- (3) Tighten the air bleeder plug.

**Tightening Torque:**

**6.9±2 N·m {70±20 kgf·cm, 5±1 lbf·ft}**

ft}

#### CAUTION

After completion of the work, wipe up any spilled water or fuel; after starting the engine, confirm that there is no fuel leakage.

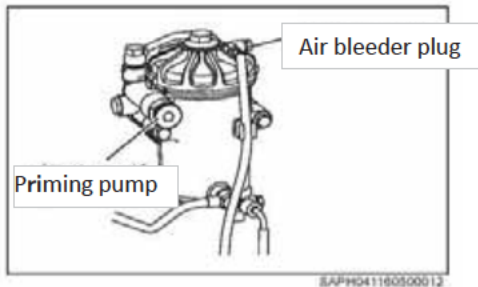

### 4) MOUNT THE INTAKE PIPE WITH EGR PIPE & VALVE.



#### \*REPLACEMENT PART

GASKET : 25634-E0020

Apply liquid gasket (equivalent to ThreeBond TB1207B, black) to the mating surface between the intake pipe and the intake manifold.

#### CAUTION

- Apply liquid gasket continuously.
- Apply liquid gasket with 1.5 to 2.5mm in width.
- Install the intake pipe to the intake manifold within 20 minutes after applying liquid gasket.

Install the intake pipe with EGR pipe and valve to the intake manifold

Tighten the bolts in left figure

**Tightening Torque:**

**28.5 N·m {290 kgf·cm, 21 lbf·ft}**

Tighten the underside bolts

**Tightening Torque:**

**55 N·m {560 kgf·cm, 41 lbf·ft}**

Replace the EGR gasket

**Tightening Torque:**

**57 N·m {580 kgf·cm, 42 lbf·ft}**

Tighten the clamp

**Tightening Torque**

**6N.m {61kgf.cm, 5lbf.ft}**

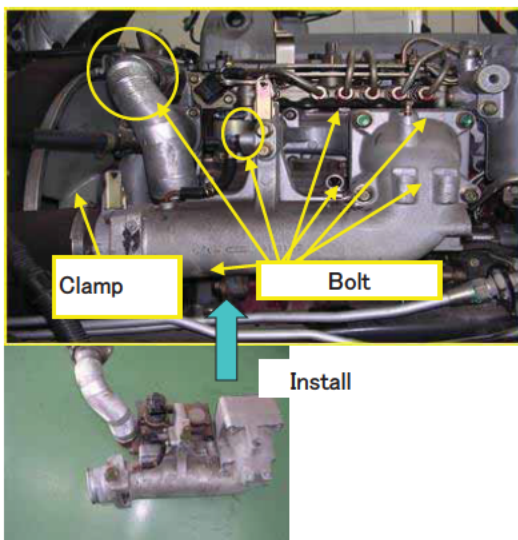

## 5) MOUNT THE AIR COMPRESSOR & EGR COOLANT PIPE.

### REPLACEMENT PART

\* SOFT WASHER : SZ209-16014



Replace the **soft washers** of joint bolts securing the air compressor coolant pipe with new ones, and tighten them.

**Tightening Torque (EGR Side):**

**29 N·m {295 kgf·cm, 21 lbf·ft}**

**Tightening Torque (Compressor Side):**

**28.5 N·m {290 kgf·cm, 21 lbf·ft}**

Replace the soft washers of joint bolts securing the coolant pipe between the water pump and the EGR cooler.

**Tightening Torque:**

**29 N·m {295 kgf·cm, 21 lbf·ft}**

## 6) ATTACH THE HARNESS ON INTAKE SIDE.

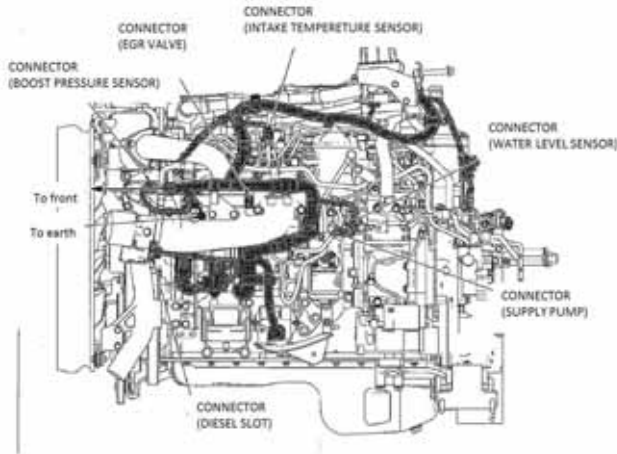

Install the coupler related to the following items.

- Injector
- EGR Valve
- Supply Pump
- Water Level Alarm Switch
- Intake Air Temperature Sensor
- Boost Pressure Sensor

## 4-14. ADD ENGINE OIL AND FILL COOLING SYSTEM

- 1) REFILL and BLEED COOLING SYSTEM - bleed EGR Cooler
- 2) FILL ENGINE WITH OIL
- 3) RECONNECT BATTERY CABLES, START THE ENGINE AND CHECK FOR FLUID/EXHAUST LEAKS. BRING ENGINE TO OPERATING TEMPERATURE, SHUT ENGINE DOWN TO COOL, RECHECK COOLANT LEVEL AND OIL LEVEL. ROAD TEST FOR PROPER OPERATION.

## 5. WARRANTY INFORMATION

Use the following information to prepare your warranty claim:

WARRANTY CODE	K763
TROUBLE CODE	05300303
FAILED PART NUMBER	12100Z501A
REPAIR DESCRIPTION	PERFORM SAFETY RECALL 17E 058
LABOR OPERATION	999X
LABOR TIME ALLOWED	28 hrs (replacing con rods)
PARTS DISPOSITION	Dispose of removed parts following local regulations