



IMPORTANT SAFETY RECALL

IMPORTANT SAFETY RECALL

MARCH 24, 2017

Subject: Recall # 17V-131 LiquidSpring Suspension

Dear {Customer Name},

This notice applies to your Wheeled Coach, Frontline, Road Rescue, Marque or McCoy-Miller Ambulance Type I with a VIN number of XXXXXXXXXXXXXXXXXXXX .

This notice is sent to you in accordance with the requirements of the National Traffic and Motor Vehicle Safety Act.

Rev Ambulance Group Orlando, Inc. (REVGO) has decided that a defect, which relates to motor vehicle safety, exists in certain 2017 Wheeled Coach, Frontline, Road Rescue, Marque or McCoy-Miller Type I Ambulances, **identified by the VIN printed above**. A component in certain suspension systems installed on 2017 Ford F350, F450, and F550 chassis, and only the suspension systems for these chassis are included in the safety recall.

We apologize for this inconvenience. We are concerned about your safety and satisfaction with our product

! I M P O R T A N T !

- Your REVGO Ambulance equipped with a certain Liquid Spring rear suspension assembly is being recalled.
- Parts to repair your vehicle are available immediately. This document contains safety inspection and retro fit part request procedure.
- Component replacement will be at no cost to you.

WHAT IS BEING RECALLED:

On certain Type I vehicles with LiquidSpring kneeling rear suspensions the rear brake banjo bolts should be inspected for any leakage and or looseness. If leakage or looseness is found, do not drive the vehicle or retighten the banjo bolt. The affected suspension systems have a serial number range 2003591 – 2004154. Continued vehicle use may result in partial or complete loss of rear service brakes which could cause damage to the chassis and/or other vehicles, and possibly result in a crash.

WHAT WE WILL DO:

If you have a Ford F350, F450, or F550 chassis equipped with a LiquidSpring suspension system within the above serial number range, please contact LiquidSpring to arrange service to have the rear brake banjo bolts replaced, free of charge. The LiquidSpring contact information is as follows: Phone: 765-474-7816 Ext. 1 for Customer Service - 8:00 a.m. – 5:00 p.m. EST Email: service@liquidspring.com



WHAT YOU AS THE OWNER SHOULD DO:

Immediately locate and inspect the affected unit(s) in your fleet. The affected suspension systems have a serial number range 2003591 – 2004154. The suspension system serial number may be found on the serial number plate located on the driver side front frame hanger of the suspension. See Figures 2 & 3 for the location and view of the serial number plate. Please contact LiquidSpring to arrange service to have the rear brake banjo bolts replaced, free of charge. The LiquidSpring contact information is as follows: Phone: 765-474-7816 Ext. 1 for Customer Service - 8:00 a.m. – 5:00 p.m. EST Email: service@liquidspring.com

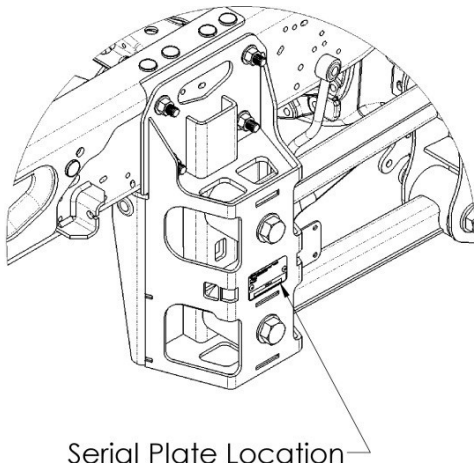

Figure 2. Serial Plate Location



Figure 3. Serial Plate

If you are unable to have your vehicle remedied without charge and in within a reasonable time, you may submit a complaint to the Administrator, National Highway Traffic Safety Administration, 1200 New Jersey Ave., S.E., Washington, D.C., 20590; or call the toll-free Vehicle Safety Hotline at 1-888-327-4236 (TTY: 1-800-424-9153); or go to <http://www.safercar.gov>.

Thank you for your prompt attention to this matter. If you have any questions concerning these procedures please contact Rev Ambulance Group Orlando, Inc. contact information is as follows: Phone: 855-661-9232 Email: revorlandoservice@revgroup.com.

Federal law requires any lessor who receives a notification of a determination of a safety-related defect or noncompliance pertaining to any leased motor vehicle shall send the notice to the lessee within 10 days. If you are no longer owner of this vehicle, please provide us with any contact information so we may contact the new owner.

Sincerely,

Ruth Gabaud
Customer Service Manager