



Michael A. Berardi
Director
Service Engineering Operations
Ford Customer Service Division

Ford Motor Company
P. O. Box 1904
Dearborn, Michigan 48121

December 1, 2017

TO: All U.S. Ford and Lincoln Dealers

**SUBJECT: NEW VEHICLE DEMONSTRATION / DELIVERY HOLD –
Compliance Recall 17C20**
Certain 2018 Model Year Expedition Vehicles
Comfort Lock Inspection and Marriage Bolt Torque

AFFECTED VEHICLES

Vehicle	Model Year	Assembly Plant	Build Dates
Expedition	2018	Kentucky	September 12, 2017 through October 31, 2017

Affected vehicles are identified in OASIS and FSA VIN Lists.

REASON FOR THIS COMPLIANCE RECALL

Some of the affected vehicles may not conform to the requirements specified by Federal Motor Vehicle Safety Standard (FMVSS) 202a Head Restraints, 207 Seating Systems, and/or FMVSS 210 Seat Belt Assembly Anchorages. An incorrectly located “Comfort Lock” latch may allow the 2nd row 40% seat(s) to be adjusted forward of the intended maximum position, which could result in improper occupant positioning. Additionally, the 2nd row 40% seat back marriage bolts may not be properly torqued, which could result in inadequate seat retention. An inadequately retained seat or improperly positioned occupant may increase the risk of injury in a crash.

SERVICE ACTION

Before demonstrating or delivering any new in-stock vehicles involved in this recall, dealers are to verify proper operation of the comfort lock latch, and verify marriage bolt alignment and torque as specified in the Technical Information. This service must be performed on all affected vehicles at no charge to the vehicle owner.

OWNER NOTIFICATION MAILING SCHEDULE

Owner letters are expected to be mailed the week of January 8, 2018. Dealers should repair any affected vehicles that arrive at their dealerships, whether or not the customer has received a letter.

PLEASE NOTE:

Federal law requires dealers to complete this recall service before a new vehicle is delivered to the buyer or lessee. Violation of this requirement by a dealer could result in a civil penalty of up to \$21,000 per vehicle. Correct all vehicles in your new vehicle inventory before delivery.

ATTACHMENTS

Attachment I: Administrative Information
Attachment II: Labor Allowances and Parts Ordering Information
Attachment III: Technical Information
Owner Notification

QUESTIONS & ASSISTANCE

For questions and assistance, contact the Special Service Support Center (SSSC) via the SSSC Web Contact Site. The SSSC Web Contact Site can be accessed through the Professional Technician Society (PTS) website using the SSSC link listed at the bottom of the OASIS VIN report screen or listed under the SSSC tab.

Sincerely,

A handwritten signature in black ink, appearing to read "Michael A. Berardi". The signature is fluid and cursive, with a prominent initial "M".

Michael A. Berardi

NEW VEHICLE DEMONSTRATION / DELIVERY HOLD – Compliance Recall 17C20

Certain 2018 Model Year Expedition Vehicles
Comfort Lock Inspection and Marriage Bolt Torque

OASIS ACTIVATION

OASIS will be activated on December 1, 2017.

FSA VIN LISTS ACTIVATION

FSA VIN Lists will be available through <https://web.fsavinlists.dealerconnection.com> December 1, 2017. Owner names and addresses will be available by January 20, 2018.

NOTE: Your FSA VIN Lists may contain owner names and addresses obtained from motor vehicle registration records. The use of such motor vehicle registration data for any purpose other than in connection with this recall is a violation of law in several states, provinces, and countries.

Accordingly, you must limit the use of this listing to the follow-up necessary to complete this recall.

SOLD VEHICLES

- Owners of affected vehicles will be directed to dealers for repairs.
- Immediately contact any of your affected customers whose vehicles are not on your VIN list but are identified in OASIS. Give the customer a copy of the Owner Notification Letter (when available) and schedule a service date.
- Correct other affected vehicles identified in OASIS which are brought to your dealership.
- Dealers are to prioritize repairs of customer vehicles over repairs of new and used vehicle inventory.

STOCK VEHICLES

- Correct all affected units in your new vehicle inventory before delivery.

DEALER-OPERATED RENTAL VEHICLES

The Fixing America's Surface Transportation (FAST) Act law effective June 2016 prohibits a rental company from selling, renting or leasing vehicles subject to a safety or compliance recall. Please consult your legal counsel for legal advice.

TITLE BRANDED / SALVAGED VEHICLES

Affected title branded and salvaged vehicles are eligible for this recall.

ADDITIONAL REPAIR (LABOR TIME AND/OR PARTS)

Additional repairs identified as necessary to complete the FSA should be managed as follows:

- For vehicles within new vehicle bumper-to-bumper warranty coverage, follow existing warranty and policy guidelines for related damage claims. No SSSC approval is required for these vehicles:
 - Ford vehicles – 3 years or 36,000 miles
- For vehicles outside new vehicle bumper-to-bumper warranty coverage, submit an Approval Request to the SSSC Web Contact Site prior to completing the repair.

NEW VEHICLE DEMONSTRATION / DELIVERY HOLD – Compliance Recall 17C20

Certain 2018 Model Year Expedition Vehicles
Comfort Lock Inspection and Marriage Bolt Torque

OWNER REFUNDS

Refunds are not approved for this program.

RENTAL VEHICLES

Dealers are pre-approved for up to 1 day for a comparable rental vehicle if seat track replacement is required. Follow Extended Service Plan (ESP) guidelines for dollar amounts. Rentals will only be reimbursed for the day(s) the vehicle is at the dealership for part replacement. Prior approval for more than 1 rental day is required from the SSSC via the SSSC Web Contact Site.

CLAIMS PREPARATION AND SUBMISSION

- Enter claims using One Warranty Solution (OWS).
 - OWS: when entering claims in DMS software, select claim type 31: Field Service Action. The FSA number (17C20) is the sub code.
- Additional labor and/or parts must be claimed as related damage on a separate repair line from the FSA.
- For rental vehicle claiming, follow Extended Service Plan (ESP) guidelines for dollar amounts. Enter the total amount of the rental expense under Miscellaneous Expense code RENTAL.

NEW VEHICLE DEMONSTRATION / DELIVERY HOLD – Compliance Recall 17C20

Certain 2018 Model Year Expedition Vehicles
Comfort Lock Inspection and Marriage Bolt Torque

LABOR ALLOWANCES

Description	Labor Operation	Labor Time
Inspect left-hand and right-hand seat comfort lock latch operation and torque marriage bolts – Vehicles equipped with a 20% center 2 nd row seat	17C20B	0.7 Hours
Inspect left-hand and right-hand seat comfort lock latch operation and torque marriage bolts – Vehicles with walk-through 2 nd row (not equipped with a 20% center 2 nd row seat)	17C20C	0.3 Hours
Replace one 2 nd row 40% seat frame assembly (Can be used with 17C20B or C)	MT17C20D	Up to 1.9 Hours
Replace both 2 nd row 40% seat frame assemblies (Do not use with 17C20B or C)	MT17C20E	Up to 3.3 Hours

PARTS REQUIREMENTS / ORDERING INFORMATION

Part Number	Description	Order Quantity	Claim Quantity
-78613A10-	* 2 nd Row 40% Seat Frame Assembly	As Required	

*** Less than 2% of the vehicles in this program are expected to require seat frame replacement.**

The DOR/COR number for this recall is 51110.

Order your parts through normal order processing channels. To guarantee the shortest delivery time, an emergency order for parts must be placed.

DEALER PRICE

For latest prices, refer to DOES II.

PARTS RETENTION AND RETURN

Follow the provisions of the Warranty and Policy Manual, Section 1 - WARRANTY PARTS RETENTION AND RETURN POLICIES.

EXCESS STOCK RETURN

Excess stock returned for credit must have been purchased from Ford Customer Service Division in accordance with Policy Procedure Bulletin 4000.

CERTAIN 2018 MODEL YEAR EXPEDITION VEHICLES — COMFORT LOCK INSPECTION AND MARRIAGE BOLT TORQUE

OVERVIEW

Some of the affected vehicles may not conform to the requirements specified by Federal Motor Vehicle Safety Standard (FMVSS) 202a Head Restraints, 207 Seating Systems, and/or FMVSS 210 Seat Belt Assembly Anchorages. An incorrectly located "Comfort Lock" latch may allow the 2nd row 40% seat(s) to be adjusted forward of the intended maximum position, which could result in improper occupant positioning. Additionally, the 2nd row 40% seat back marriage bolts may not be properly torqued, which could result in inadequate seat retention. An inadequately retained seat or improperly positioned occupant may increase the risk of injury in a crash.

Before demonstrating or delivering any new in-stock vehicles involved in this recall, dealers are to verify proper operation of the comfort lock latch, and verify marriage bolt alignment and torque. This service must be performed on all affected vehicles at no charge to the vehicle owner.

SERVICE PROCEDURE

Recommended Tool List:

Plastic Trim Tool
3/8" Drive Torque Wrench
1/4" and 3/8" Drive Hand and Power Ratchet
1/4" Drive Sockets- T-20
3/8" Drive Socket - 13mm, T-30, T-45
1/4" Drive Extension- 6 in (152 mm)
Tape Measure



Seat Position Comfort Lock Inspection

1. With the seats in their most forward position (Comfort Lock Forward Position), measure the position of both the RH and LH 2nd row 40% seats. See Figures 1 and 2.

NOTE: Seatback folded down in Figure 1 for photographic purposes only.

- a. With the seatback upright and the seat in the full rearward position, lift up on the "towel bar" under the seat and slide the seat to the full forward position.
- b. Measure the distance from the "arrow point" of the seat frame cover to the end of the seat track trim cover on the inboard side.
- c. Repeat steps "a" and "b" five (5) times on both the RH and LH seat.



FIGURE 1



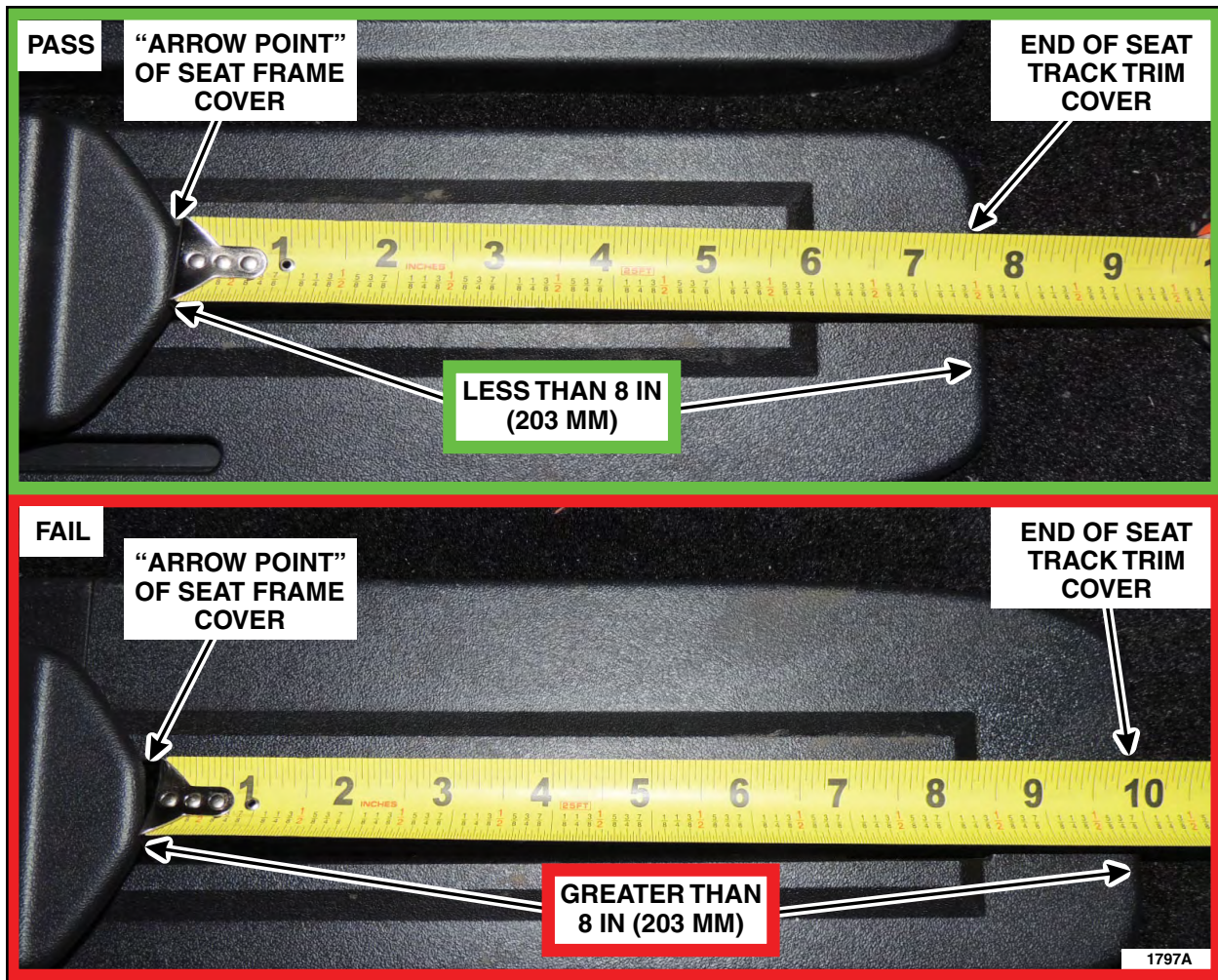

FIGURE 2

2. Was the measurement equal to or less than 8.0 in (203 mm)?

Yes – Proceed to "Marriage Bolt Inspection and Re-torque" procedure.

No – Replace the affected 2nd row 40% seat frame assembly. Transfer components from the original seat frame to the *new* assembly as required. Please follow the Workshop Manual (WSM) procedures in Section 501-10B. Repair is complete for that seat assembly.

- Transfer components as required.



Marriage Bolt Inspection and Re-torque

1. Does the vehicle have a walk-through 2nd row (no console or 20% seat)?

Yes – Proceed to Step 2.

No – Remove the RH and LH 40% 2nd row seats. Please follow the WSM procedures in Section 501-10B, then proceed to Step 2.

2. Release the retainers and remove the recline handle cover. See Figure 3.

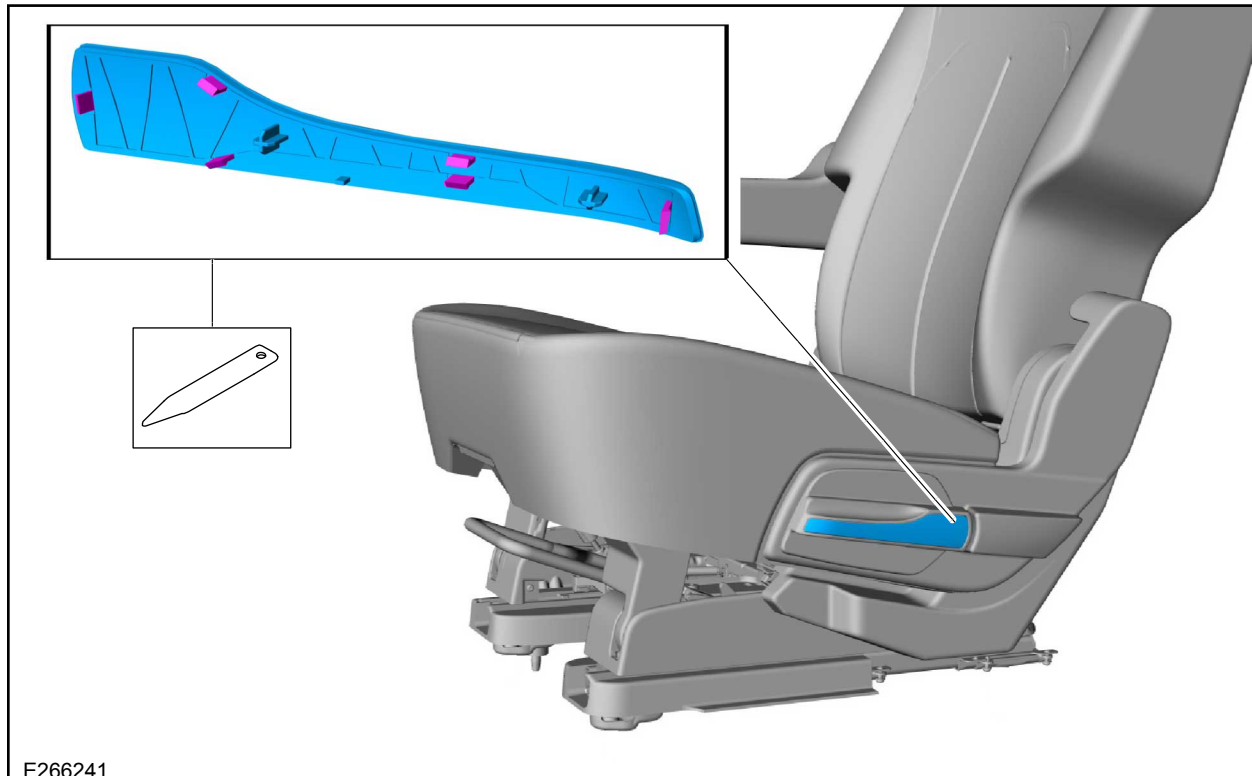
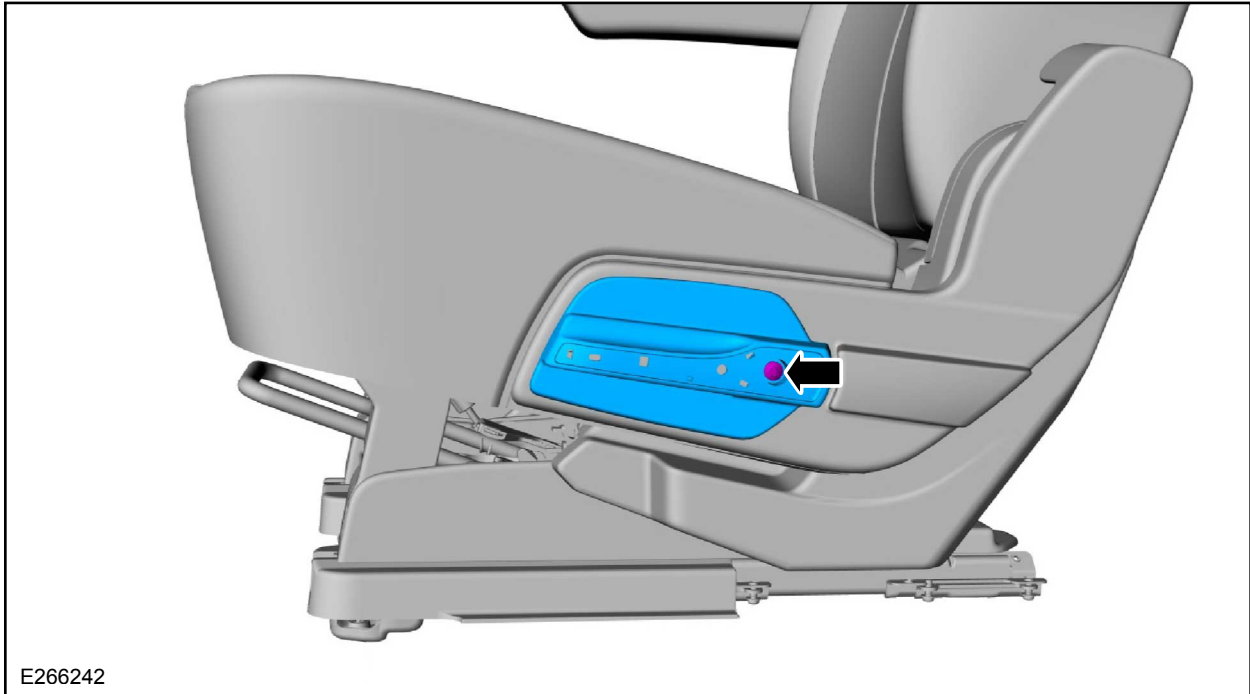

FIGURE 3



3. Remove screw and the recline handle. See Figure 4.



E266242

FIGURE 4

4. Remove the screws, release the retainers and remove the second row seat side shield. See Figure 5.

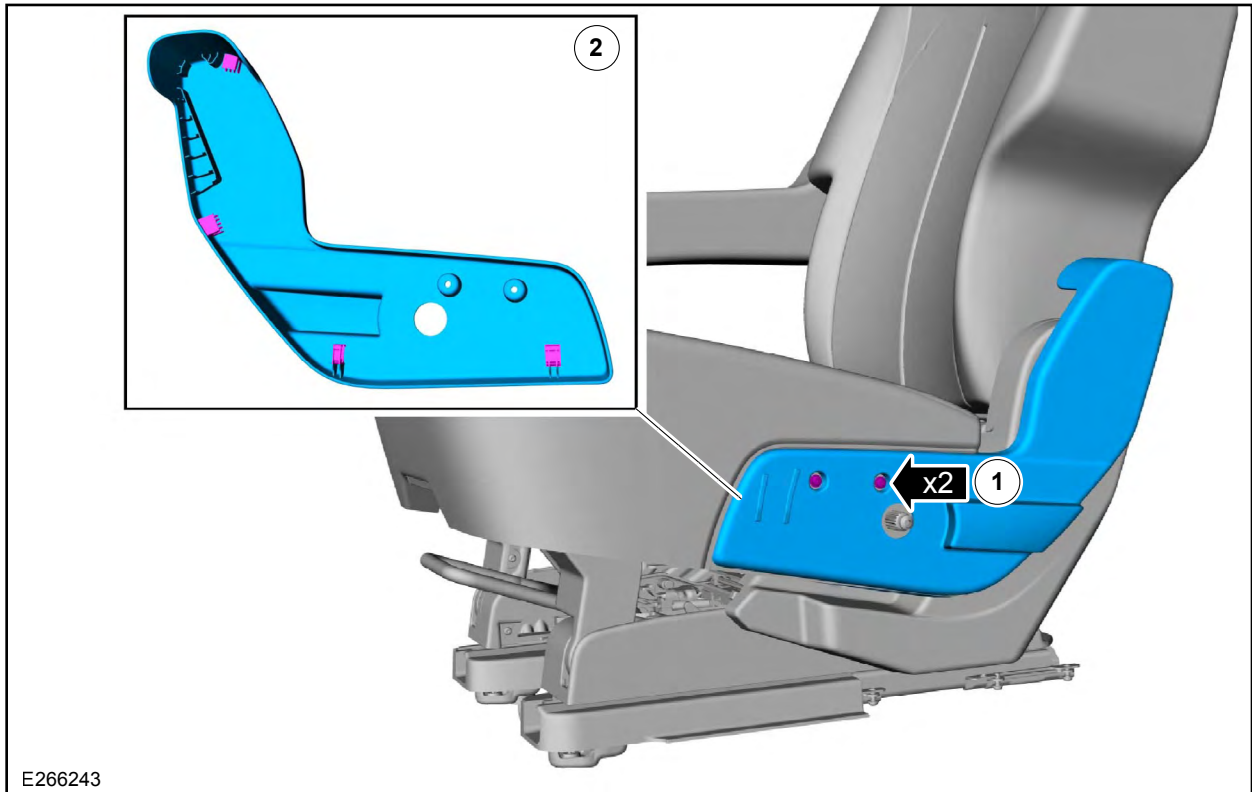

E266243

FIGURE 5



5. Remove the screws, release the retainers and remove the second row seat cushion pivot arm cover.
See Figure 6.

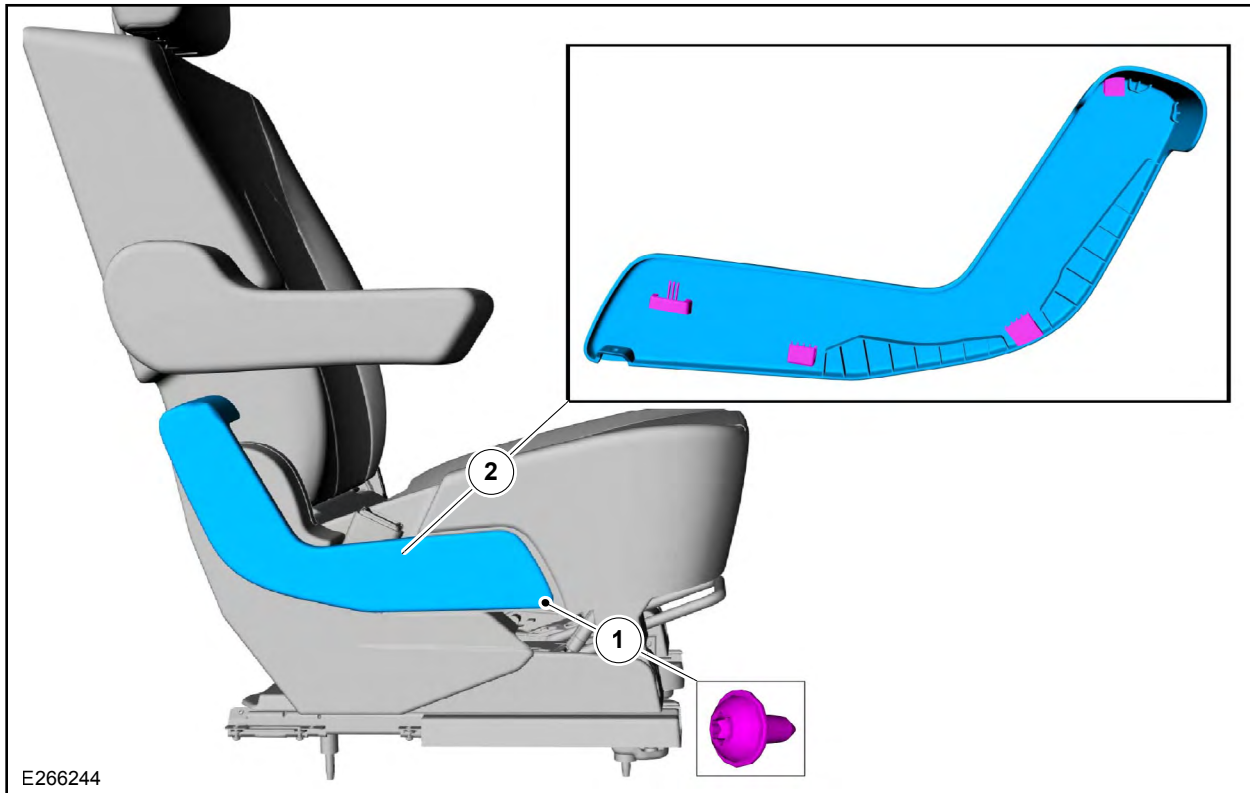

E266244

FIGURE 6



6. Verify the marriage bolts (2 per seat, four total), pivot shaft bushings and seat frames are properly aligned. See Figure 7.

- Tighten bolts to 15 Nm (11 lb-ft).

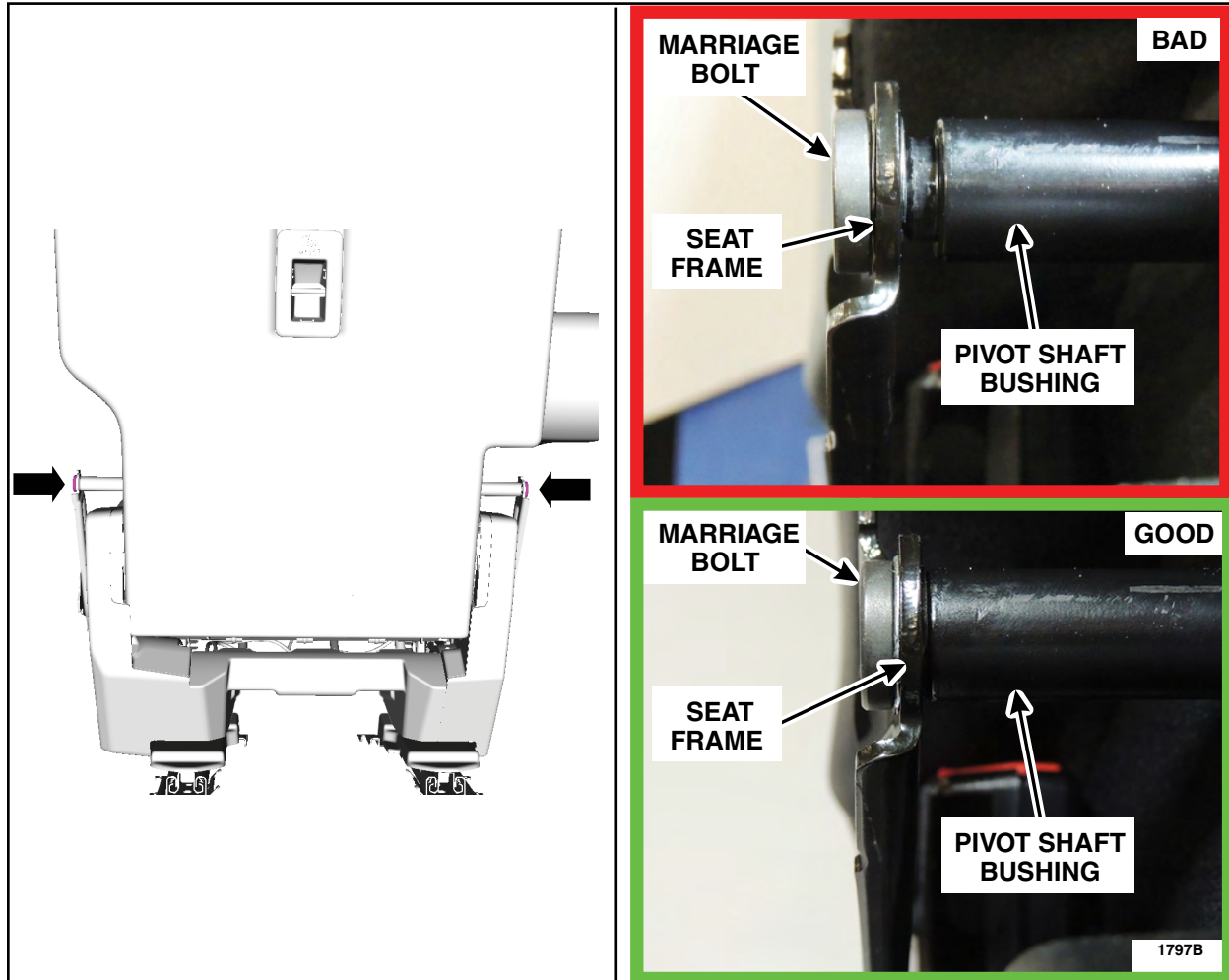

FIGURE 7

7. Install the second row seat cushion pivot arm cover and screws. See Figure 6.
8. Install the second row seat side shield and screws. See Figure 5.
9. Install the recline handle and screw. See Figure 4.
10. Install the recline handle cover. See Figure 3.
11. If removed, install the RH and LH 40% 2nd row seats. Please follow the WSM procedures in Section 501-10B.

