



David J. Johnson  
Director  
Service Engineering Operations  
Ford Customer Service Division

Ford Motor Company  
P. O. Box 1904  
Dearborn, Michigan 48121

January 17, 2018

**TO:** All U.S. Ford and Lincoln Dealers

**SUBJECT: NEW VEHICLE DEMONSTRATION / DELIVERY HOLD  
Safety Recall 17S41**

Certain 2017 Model Year F-53 Motorhome Chassis and F-59 Commercial Stripped  
Chassis Vehicles  
4 Channel Hydraulic Brakes - Missing Ball Plugs

**AFFECTED VEHICLES**

Vehicle	Model Year	Assembly Plant	Build Dates
F-53/F-59	2017	Detroit Chassis	November 10, 2016 through November 17, 2016

Affected vehicles are identified in OASIS and FSA VIN Lists.

**REASON FOR THIS SAFETY RECALL**

In some of the affected vehicles, the Hydraulic Electronic Control Unit (HECU) may have been built without ball plugs in the hydraulic block. This could result in air ingestion or brake fluid leaking during an Electronic Brake Distribution (EBD) or Anti-lock Brake System (ABS) activation.

- Air ingestion may result in unexpected, increased brake pedal travel.
- The amount of brake fluid that leaks is dependent on the number and duration of EBD and ABS events that occur. Sufficient loss of brake fluid may result in increased pedal travel and/or increased stopping distance, and may illuminate the brake warning light.

These conditions may increase the risk of a crash.

**SERVICE ACTION**

Before demonstrating or delivering any new in-stock vehicles involved in this recall, dealers are to inspect the hydraulic block, and replace the HECU if the ball plugs are not present. This service must be performed on all affected vehicles at no charge to the vehicle owner.

**OWNER NOTIFICATION MAILING SCHEDULE**

Owner letters are expected to be mailed the week of January 22, 2018. Dealers should repair any affected vehicles that arrive at their dealerships, whether or not the customer has received a letter.

**PLEASE NOTE:**

**Federal law requires dealers to complete this recall service before a new vehicle is delivered to the buyer or lessee. Violation of this requirement by a dealer could result in a civil penalty of up to \$21,000 per vehicle. Correct all vehicles in your new vehicle inventory before delivery.**

**ATTACHMENTS**

Attachment I: Administrative Information  
Attachment II: Labor Allowances and Parts Ordering Information  
Attachment III: Technical Information  
Owner Notification Letters  
Recall Reimbursement Plan

**QUESTIONS & ASSISTANCE**

For questions and assistance, contact the Special Service Support Center (SSSC) via the SSSC Web Contact Site. The SSSC Web Contact Site can be accessed through the Professional Technician Society (PTS) website using the SSSC link listed at the bottom of the OASIS VIN report screen or listed under the SSSC tab.

Sincerely,

A handwritten signature in cursive script, appearing to read "D. Johnson".

David J. Johnson

**NEW VEHICLE DEMONSTRATION / DELIVERY HOLD**

**Safety Recall 17S41**

Certain 2017 Model Year F-53 Motorhome Chassis and F-59 Commercial Stripped Chassis Vehicles  
4 Channel Hydraulic Brakes - Missing Ball Plugs

**OASIS ACTIVATION**

OASIS was activated on December 1, 2017.

**FSA VIN LISTS ACTIVATION**

FSA VIN Lists were available through <https://web.fsavinlists.dealerconnection.com> on December 1, 2017. Owner names and addresses will be available by February 6, 2018.

**NOTE:** Your FSA VIN Lists may contain owner names and addresses obtained from motor vehicle registration records. The use of such motor vehicle registration data for any purpose other than in connection with this recall is a violation of law in several states, provinces, and countries.

Accordingly, you must limit the use of this listing to the follow-up necessary to complete this recall.

**SOLD VEHICLES**

- Owners of affected vehicles will be directed to dealers for repairs.
- Immediately contact any of your affected customers whose vehicles are not on your VIN list but are identified in OASIS. Give the customer a copy of the Owner Notification Letter (when available) and schedule a service date.
- Correct other affected vehicles identified in OASIS which are brought to your dealership.
- Dealers are to prioritize repairs of customer vehicles over repairs of new and used vehicle inventory.

**STOCK VEHICLES**

- Correct all affected units in your new vehicle inventory before delivery.

**DEALER-OPERATED RENTAL VEHICLES**

The Fixing America's Surface Transportation (FAST) Act law effective June 2016 prohibits a rental company from selling, renting or leasing vehicles subject to a safety or compliance recall. Please consult your legal counsel for legal advice.

**TITLE BRANDED / SALVAGED VEHICLES**

Affected title branded and salvaged vehicles are eligible for this recall.

**ADDITIONAL REPAIR (LABOR TIME AND/OR PARTS)**

Additional repairs identified as necessary to complete the FSA should be managed as follows:

- For vehicles within new vehicle bumper-to-bumper warranty coverage, follow existing warranty and policy guidelines for related damage claims. No SSSC approval is required for these vehicles:
- For vehicles outside new vehicle bumper-to-bumper warranty coverage, submit an Approval Request to the SSSC Web Contact Site prior to completing the repair.

**[NEW VEHICLE DEMONSTRATION / DELIVERY HOLD  
Safety Recall 17S41**

Certain 2017 Model Year F-53 Motorhome Chassis and F-59 Commercial Stripped Chassis Vehicles  
4 Channel Hydraulic Brakes - Missing Ball Plugs

**OWNER REFUNDS**

- Ford Motor Company is offering a refund for owner-paid repairs covered by this recall if the repair was performed prior to the date indicated in the reimbursement plan, which is posted with this bulletin. Owners are directed to seek reimbursement through authorized dealers or, at their option, directly through Ford Motor Company at P.O. Box 6251, Dearborn, MI 48121-6251.
- Dealers are also pre-approved to refund owner-paid emergency repairs that were performed away from an authorized servicing dealer after the end date specified in the reimbursement plan. Non-covered repairs, or those judged by Ford to be excessive, will not be reimbursed.
- Refunds will only be provided for the cost associated with HECU replacement.

**RENTAL VEHICLES**

Rental vehicles are not approved for this program.

**CLAIMS PREPARATION AND SUBMISSION**

- Enter claims using Direct Warranty Entry (DWE) or One Warranty Solution (OWS).
  - DWE: refer to ACESII manual for claims preparation and submission information.
  - OWS: when entering claims in DMS software, select claim type 31: Field Service Action. The FSA number 17S41 is the sub code.
- Additional labor and/or parts must be claimed as related damage on a separate repair line from the FSA.
- Submit refunds on a separate repair line.
  - Program Code: 17S41
  - Misc. Expense: ADMIN
  - Misc. Expense: REFUND
  - Misc. Expense: 0.2 Hrs.
- Multiple refunds should be submitted on one repair line and the invoice details for each repair should be detailed in the comments section of the claim.

**NEW VEHICLE DEMONSTRATION / DELIVERY HOLD****Safety Recall 17S41**

Certain 2017 Model Year F-53 Motorhome Chassis and F-59 Commercial Stripped Chassis Vehicles  
4 Channel Hydraulic Brakes - Missing Ball Plugs

**LABOR ALLOWANCES**

Description	Labor Operation	Labor Time
Replace (includes inspect and brake bleed) ABS Hydraulic Electronic Control Unit	MT17S41A	Actual Time up to 1.5 Hours

**PARTS REQUIREMENTS / ORDERING INFORMATION**

Part Number	Description	Order Quantity	Claim Quantity
GU9Z-2C215-B	ABS Hydraulic Electronic Control Unit	1	1

Order your parts through normal order processing channels. To guarantee the shortest delivery time, an emergency order for parts must be placed.

**DEALER PRICE**

For latest prices, refer to DOES II.

**PARTS RETENTION AND RETURN**

Follow the provisions of the Warranty and Policy Manual, Section 1 - WARRANTY PARTS RETENTION AND RETURN POLICIES.

**EXCESS STOCK RETURN**

Excess stock returned for credit must have been purchased from Ford Customer Service Division in accordance with Policy Procedure Bulletin 4000.

**CERTAIN 2017 MODEL YEAR F-53 MOTORHOME CHASSIS AND F-59 COMMERCIAL STRIPPED CHASSIS VEHICLES — 4 CHANNEL HYDRAULIC BRAKES - MISSING BALL PLUGS**

**OVERVIEW**

In some of the affected vehicles, the Hydraulic Electronic Control Unit (HECU) may have been built without ball plugs in the hydraulic block. This could result in air ingestion or brake fluid leaking during an Electronic Brake Distribution (EBD) or Anti-Lock Brake System (ABS) activation. Air ingestion may result in unexpected, increased brake pedal travel. The amount of brake fluid that leaks is dependent on the number and duration of EBD and ABS events that occur. Sufficient loss of brake fluid may result in increased pedal travel and/or increased stopping distance, and may illuminate the brake warning light. These conditions may increase the risk of a crash.

Before demonstrating or delivering any new in-stock vehicles involved in this recall, dealers are to inspect the hydraulic block, and replace the HECU if the ball plugs are not present. This service must be performed on all affected vehicles at no charge to the vehicle owner.

**SERVICE PROCEDURE**

**Recommended Tool List:**

General Tools	General Equipment
3/8" Drive Torque Wrench	Inspection Mirror
3/8" Drive Ratchet	Torque Adapter
3/8" Drive Ratchet Power	
3/8" Drive 10mm and 13mm Deep Sockets	
10mm and 13mm Flex Head Ratchet Wrench	

1. Disconnect the ABS electrical connector from the Hydraulic Electronic Control Unit (HECU). See Figure 1.

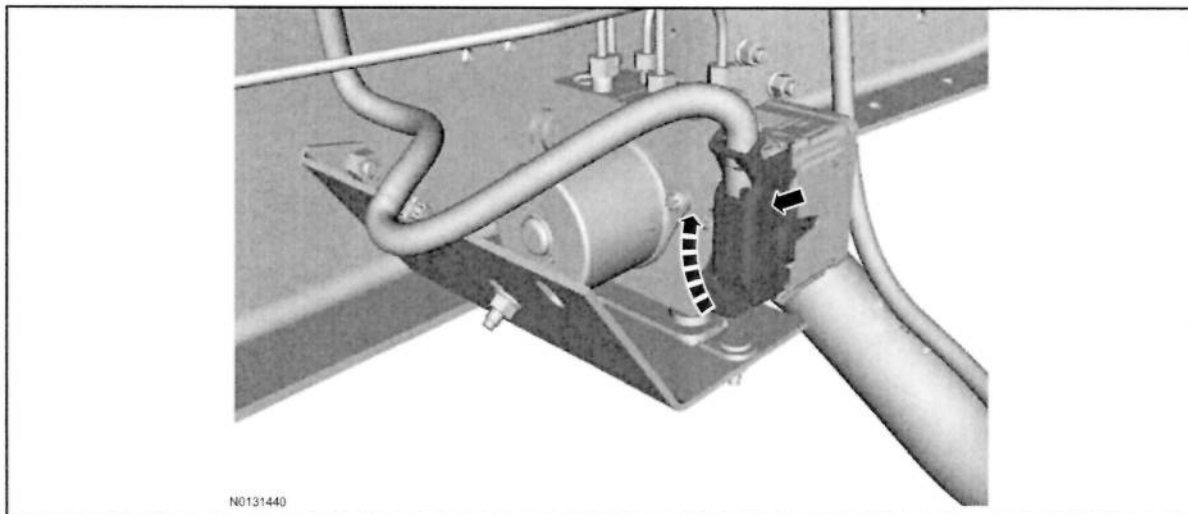

**FIGURE 1**



2. Visually inspect the HECU for the three ball plugs on the inboard side of the unit. See Figure 2.

- If all the inboard ball plugs are present proceed to Step 3.
- If any of the inboard ball plugs are missing replace the HECU, following the Work Shop Manual procedures in Section 206-09.

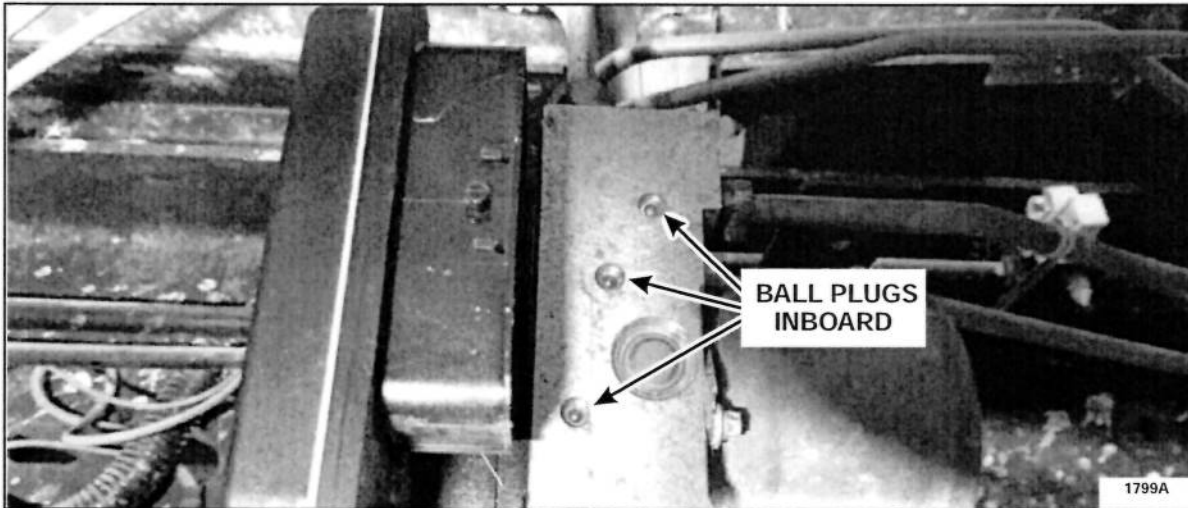

FIGURE 2

3. Remove three nuts and position the HECU and bracket assembly off of the vehicle frame. See Figure 3.

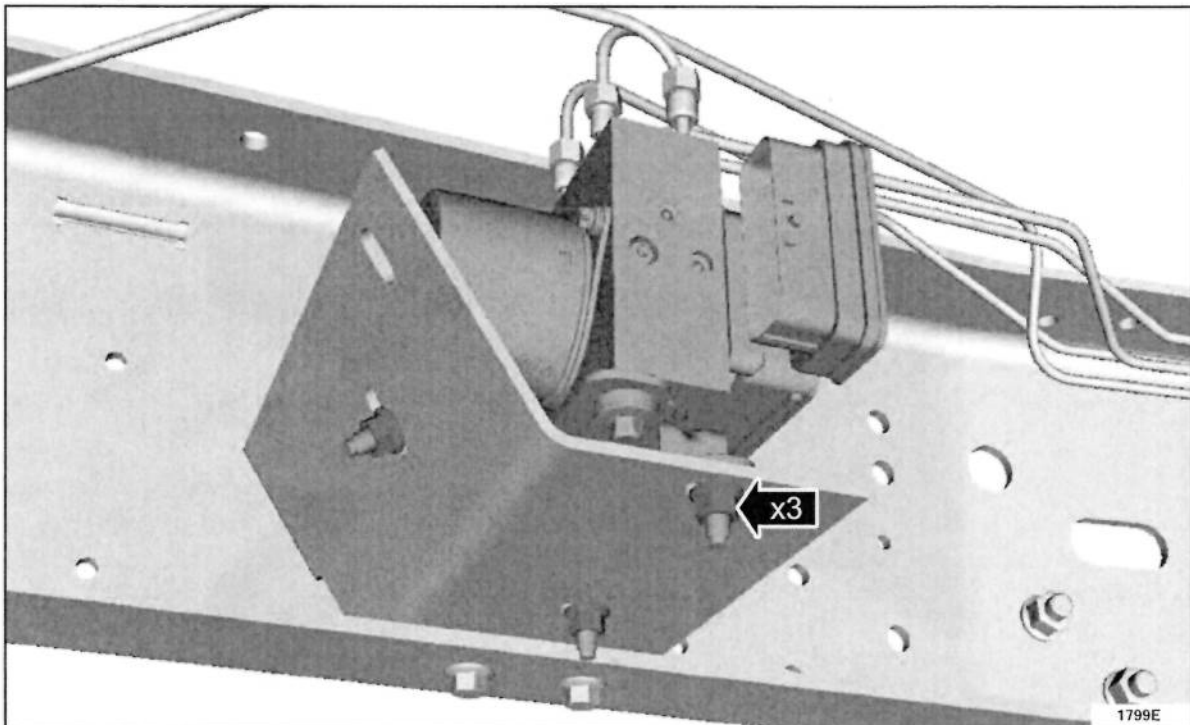
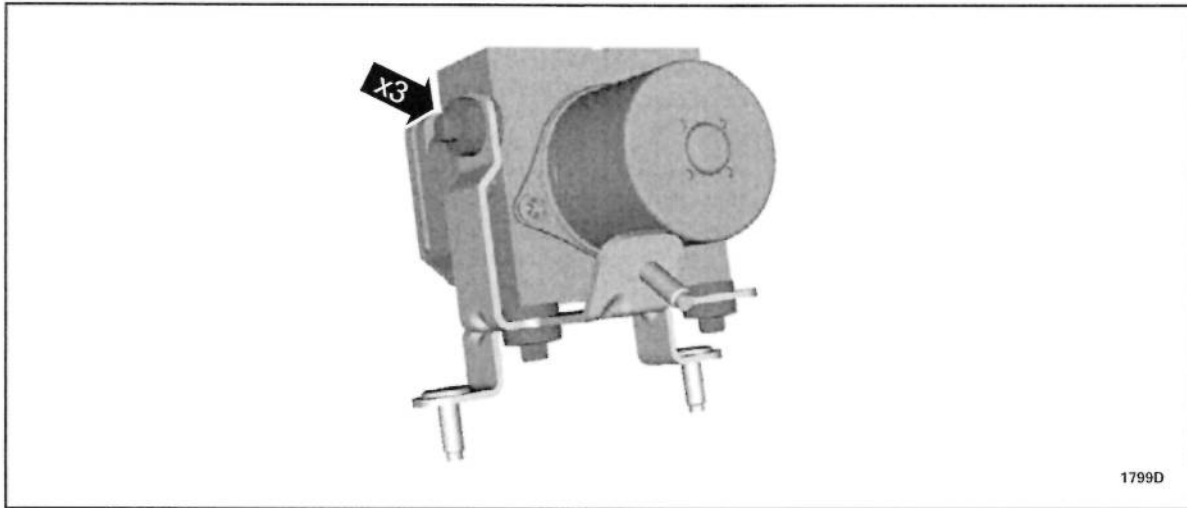

FIGURE 3



4. Remove the three bolts and the HECU mounting bracket. See Figure 4.



**FIGURE 4**

5. Inspect the outboard side of the HECU for all four ball plugs. See Figure 5.

- If all the outboard ball plugs are present proceed to Step 6.
- If any of the outboard ball plugs are missing replace the HECU, following the Work Shop Manual procedures in Section 206-09.

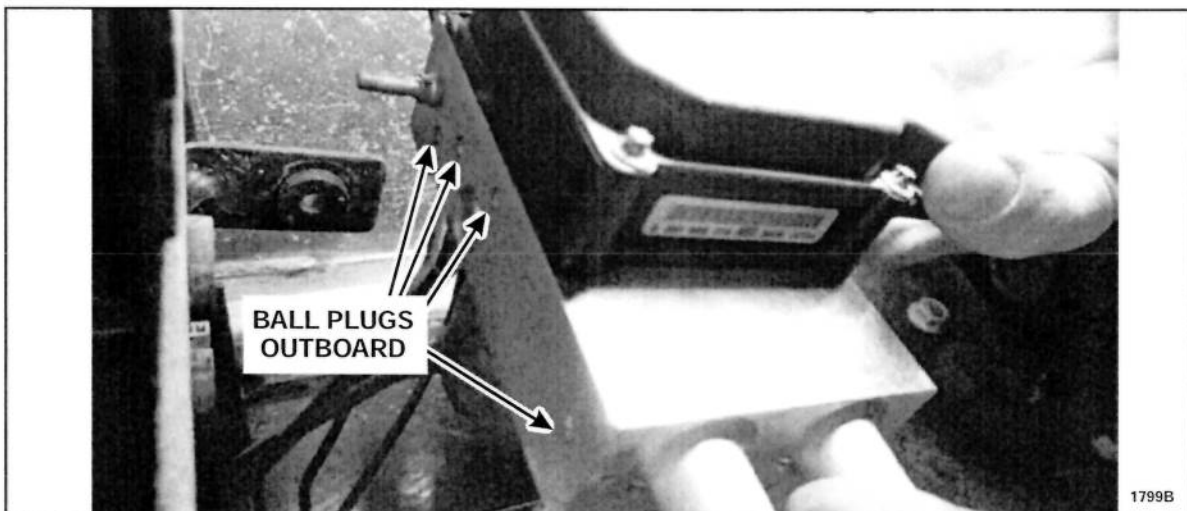

**FIGURE 5**

6. Install the HECU bracket and three bolts back onto the HCU. See Figure 4.

- Tighten to 15 Nm (133 ib-in).

7. Install the HECU and bracket assembly back on to the vehicle frame. See Figure 3.

- Tighten to 30 Nm (22 ib-ft).

8. Connect the ABS electrical connector to the HECU. See Figure 1.





**Ford Motor Company**  
**Recall Reimbursement Plan for 17S41**

*Ford and Lincoln dealers are in the best position to quickly and efficiently process reimbursement requests. However, federal legislation requires all motor vehicle manufacturers to establish processes through which customers may seek recall reimbursement directly from the manufacturer or from the dealers.*

*Regarding the specific reimbursement plan for Recall # 17S41, owners who have paid for service to remedy the defect or noncompliance must have had that service performed prior to February 5, 2018. After this date, if repairs related to this recall are performed by a non-Ford repair facility in an emergency situation, customers must submit any refund requests through their dealership. As required by this federal regulation, Ford Motor Company submitted the details of its latest General Recall Reimbursement Plan in a letter to the National Highway Traffic Safety Administration (NHTSA) in February 2015. The following is the text of that letter and the Plan:*

**General Recall Reimbursement Plan**  
(As submitted to the NHTSA)

Pursuant to the requirements set forth in 49 CFR Part 573 and Part 577 of the Code of Federal Regulations, Ford Motor Company (Ford) is submitting required information pertaining to our general reimbursement plan for the cost of remedies paid for by vehicle owners before they are notified of a related safety recall.

Set forth below is Ford's general plan to reimburse owners and purchasers for costs incurred for remedies in advance of notification of potential safety-related defects or noncompliance's pursuant to Part 573.6 (c)(8)(i). This plan has not changed since our February 20, 2015 submission.

**Reimbursement Notification**

Ford's notice to a vehicle owner in accordance with 49 CFR Part 577 will indicate that Ford is offering a refund if the owner paid to have service to remedy the defect or noncompliance prior to a specified ending date. In accordance with Part 573.13 (c)(2), this ending date will be defined as a minimum of ten calendar days after the date on which Ford mailed the last of its Part 577 notifications to owners, and will be indicated in the specific reimbursement plan available to owners for an individual recall. This notice will direct owners to seek eligible reimbursement through authorized dealers or, at their option, directly through Ford at the following address:

Ford Motor Company  
P.O. Box 6251  
Dearborn, MI 48121-6251

Ford notes that this rule allows for the identification of a beginning date for reimbursement eligibility. Under the rule, an owner who paid to remedy the defect or noncompliance prior to the identified beginning date would not be eligible for reimbursement. Ford generally has not established such a beginning date for reimbursement eligibility and does not presently anticipate changing this general policy. However, in any case where Ford determines a beginning date is appropriate, Ford will indicate that date in the owner notice. As permitted by 577.11(e), Ford may not include a reimbursement notification when all vehicles are well within the warranty period, subject to approval by the agency.

## **Costs to be Reimbursed**

For vehicles, reimbursement will not be less than the lesser of:

- The amount paid by the owner for the remedy that specifically addressed and was reasonably necessary to correct the defect or noncompliance that is the subject of the recall, or
- The cost of parts for the remedy (to be no more than the manufacturer's list retail price for authorized part(s), plus associated labor at local labor rates, miscellaneous fees (such as disposal of waste) and taxes.

For replacement equipment, reimbursement will be the amount paid by the owner for the replacement item (limited by the amount of the retail list price of the defective or noncompliant item that was replaced, plus taxes, where the brand or model purchased by the owner was different than the brand or model that was the subject of the recall). If the item of motor vehicle equipment was repaired, the reimbursement provisions identified above for vehicles will apply.

Ford notes that costs incurred by the owner within the period during which Ford's original or extended warranty would have provided for a free repair of the problem will not be eligible for reimbursement, as provided by Part 573.13 (d)(1).

### Entities Authorized to Provide Reimbursement

Ford will continue to use authorized dealers to reimburse owners under the specific reimbursement plans for a particular recall, and will encourage owners to pursue requests for reimbursement directly through dealers to expedite reimbursement. Ford will also provide a mailing address to which customers can, at their option, send requests for reimbursement directly to Ford, as previously noted. Requests for reimbursement sent directly to Ford may take up to 60 days to process. Whether the owner chooses to pursue reimbursement requests through a dealer or directly through Ford, the owner will be directed to submit the required documentation, upon which reimbursement eligibility will be determined.

## **Required Documentation**

The reimbursement determination will depend upon the information provided by the customer. Consistent with Part 573.13 (d)(4) the following information must be submitted:

- Claimant name and address
- Vehicle make, model, and model year
- Vehicle identification number (VIN) and, for replacement equipment, a description of such equipment or, for tires, the model, size and TIN (DOT code)
- Identification of the recall number (either the Ford recall number or the NHTSA recall number)
- Identification of the owner of the recalled vehicle at the time that the pre-notification remedy was obtained
- An original receipt for the pre-notification remedy that includes a breakdown of the amount for parts, labor, other costs and taxes, including costs for the replacement item. Where the receipt covers work other than to address the recall or noncompliance, Ford may require the claimant to separately identify costs that are eligible for reimbursement.
- If the remedy was obtained during the warranty period, documentation indicating that the warranty was not honored or the warranty repair did not correct the problem related to the recall.

Failure to submit all of the above information may result in denial of the reimbursement request.

**Additional Information**

The Part 577 required owner notice will provide a toll-free telephone number through which specific information about the reimbursement plan can be requested from Ford. This general reimbursement plan will be incorporated into notifications pursuant to Part 573.6 by reference. Information specific to an individual recall also may be incorporated into the Part 573.6 notification.