



Michael A. Berardi  
Director  
Service Engineering Operations  
Ford Customer Service Division

Ford Motor Company  
P. O. Box 1904  
Dearborn, Michigan 48121

November 7, 2017

**TO:** All U.S. Ford and Lincoln Dealers

**SUBJECT: NEW VEHICLE DEMONSTRATION / DELIVERY HOLD - Safety Recall 17S36**  
Certain 2017 Model Year F-150 Vehicles with a 10R80 Transmission  
Transmission Roll Pin Replacement

**AFFECTED VEHICLES**

Vehicle	Model Year	Assembly Plant	Build Dates
F-150	2017	Dearborn	23-August-2016 through 02-July-2017
		Kansas City	16-September-2016 through 09-August-2017
F-150	2017	Certain vehicles serviced with transmission assembly part numbers HL3Z-7000-E, HL3Z-7000-F or HL3Z-7000-H	

Affected vehicles are identified in OASIS and FSA VIN Lists.

Note: The affected vehicles have changed since the Advance Notice, published on October 24, 2017.

**REASON FOR THIS SAFETY RECALL**

In some of the affected vehicles, the roll pin attaching the transmission shift linkage to the transmission may come out. If this happens, movement of the shift lever by the driver will not change the transmission gear state. The transmission will remain in the gear it was in when the pin came out regardless of the position of the shift lever.

If the roll pin comes out, a driver may experience any of the following:

- A loose or low effort feel of the shift lever
- If the vehicle is equipped with a floor shifter, the shifter indicator could display inaccurate gear position
- When exiting the vehicle, if the transmission is not in Park, the ignition key can be removed, but a warning chime will sound and a message will be displayed in the instrument cluster indicating Transmission Not in Park
- If the transmission is not in Park or Neutral, the driver would not be able to restart the vehicle
- If the vehicle cannot be shifted to Park and the parking brake is not applied, unintended vehicle movement may occur, increasing the risk of accident or injury

**SERVICE ACTION**

Before demonstrating or delivering any new in-stock vehicles involved in this recall, dealers are to replace the transmission shift linkage roll pin. This service must be performed on all affected vehicles at no charge to the vehicle owner.

**When operating affected vehicles prior to repair, make sure the parking brake is applied whenever the vehicle is parked.**

**SERVICE ACTION (Continued)**

In addition, 16 service transmission assemblies sold to dealers are affected. Dealers are to use the chart below to identify certain service part sales and vehicles serviced by your dealership with the following transmission assembly service part numbers:

HL3Z-7000-E	HL3Z-7000-F	HL3Z-7000-H
-------------	-------------	-------------

If dealership records indicate that an over-the-counter service part sale occurred, or that a vehicle was serviced with one of the parts listed, and the vehicle is not identified in OASIS, dealers should:

- Obtain the transmission assembly serial number
- Submit a VIN specific Non-Involved Vehicle Request contact to the Special Service Support Center (SSSC) via the SSSC Web Contact Site. Please provide documentation including transmission serial number, sales invoice or repair order showing the use of the part on the vehicle.
- If the SSSC approves the addition, contact the owner and arrange a service date.
- When the vehicle arrives, provide the customer with a copy of the Owner Notification Letter.

**OWNER NOTIFICATION MAILING SCHEDULE**

Owner letters are expected to be mailed the week of December 11, 2017. Dealers should repair any affected vehicles that arrive at their dealerships, whether or not the customer has received a letter.

**PLEASE NOTE:**

**Federal law requires dealers to complete this recall service before a new vehicle is delivered to the buyer or lessee. Violation of this requirement by a dealer could result in a civil penalty of up to \$21,000 per vehicle. Correct all vehicles in your new vehicle inventory before delivery.**

**ATTACHMENTS**

- Attachment I: Administrative Information
- Attachment II: Labor Allowances and Parts Ordering Information
- Attachment III: Technical Information
- Owner Notification Letter

**QUESTIONS & ASSISTANCE**

For questions and assistance, contact the SSSC via the SSSC Web Contact Site. The SSSC Web Contact Site can be accessed through the Professional Technician Society (PTS) website using the SSSC link listed at the bottom of the OASIS VIN report screen or listed under the SSSC tab.

Sincerely,



Michael A. Berardi

**NEW VEHICLE DEMONSTRATION / DELIVERY HOLD - Safety Recall 17S36**

Certain 2017 Model Year F-150 Vehicles with a 10R80 Transmission  
Transmission Roll Pin Replacement

**OASIS ACTIVATION**

OASIS was activated on October 24, 2017.

**FSA VIN LISTS ACTIVATION**

FSA VIN Lists were made available through <https://web.fsavinlists.dealerconnection.com> on October 24, 2017. Owner names and addresses will be available by December 22, 2017.

**NOTE:** Your FSA VIN Lists may contain owner names and addresses obtained from motor vehicle registration records. The use of such motor vehicle registration data for any purpose other than in connection with this recall is a violation of law in several states, provinces, and countries.

Accordingly, you must limit the use of this listing to the follow-up necessary to complete this recall.

**SOLD VEHICLES**

- Owners of affected vehicles will be directed to dealers for repairs.
- Immediately contact any of your affected customers whose vehicles are not on your VIN list but are identified in OASIS. Give the customer a copy of the Owner Notification Letter (when available) and schedule a service date.
- Correct other affected vehicles identified in OASIS which are brought to your dealership.
- Dealers are to prioritize repairs of customer vehicles over repairs of new and used vehicle inventory.

**STOCK VEHICLES**

- Correct all affected units in your new vehicle inventory before delivery.
- Use OASIS to identify any affected vehicles in your used vehicle inventory.

**DEALER-OPERATED RENTAL VEHICLES**

The Fixing America's Surface Transportation (FAST) Act law effective June 2016 prohibits a rental company from selling, renting or leasing vehicles subject to a safety or compliance recall. Please consult your legal counsel for legal advice.

**TITLE BRANDED / SALVAGED VEHICLES**

Affected title branded and salvaged vehicles are eligible for this recall.

**ADDITIONAL REPAIR (LABOR TIME AND/OR PARTS)**

Additional repairs identified as necessary to complete the FSA should be managed as follows:

- For vehicles within new vehicle bumper-to-bumper warranty coverage, follow existing warranty and policy guidelines for related damage claims. No SSSC approval is required for these vehicles:
  - Ford vehicles – 3 years or 36,000 miles
- For vehicles outside new vehicle bumper-to-bumper warranty coverage, submit an Approval Request to the SSSC Web Contact Site prior to completing the repair.

**NEW VEHICLE DEMONSTRATION / DELIVERY HOLD - Safety Recall 17S36**

Certain 2017 Model Year F-150 Vehicles with a 10R80 Transmission  
Transmission Roll Pin Replacement

**OWNER REFUNDS**

Refunds are not approved for this program.

**RENTAL VEHICLES**

Rental vehicles are not approved for this program.

**CLAIMS PREPARATION AND SUBMISSION**

- Enter claims using Direct Warranty Entry (DWE) or One Warranty Solution (OWS).
  - DWE: refer to ACESII manual for claims preparation and submission information.
  - OWS: when entering claims in DMS software, select claim type 31: Field Service Action. The FSA number 17S36 is the sub code.
- Additional labor and/or parts must be claimed as related damage on a separate repair line from the FSA.

**NEW VEHICLE DEMONSTRATION / DELIVERY HOLD - Safety Recall 17S36**

Certain 2017 Model Year F-150 Vehicles with a 10R80 Transmission  
Transmission Roll Pin Replacement

**LABOR ALLOWANCES**

Description	Labor Operation	Labor Time
Replace the transmission shift linkage roll pin	17S36B	1.7 Hours

**PARTS REQUIREMENTS / ORDERING INFORMATION**

Part Number	Description	Order Quantity	Claim Quantity
HL3Z-7G100-B	Roll pin	1	1

Order your parts through normal order processing channels. To guarantee the shortest delivery time, an emergency order for parts must be placed.

**DEALER PRICE**

For latest prices, refer to DOES II.

**PARTS RETENTION AND RETURN**

Follow the provisions of the Warranty and Policy Manual, Section 1 - WARRANTY PARTS RETENTION AND RETURN POLICIES.

**EXCESS STOCK RETURN**

Excess stock returned for credit must have been purchased from Ford Customer Service Division in accordance with Policy Procedure Bulletin 4000.

## CERTAIN 2017 MODEL YEAR F-150 VEHICLES EQUIPPED WITH A 10R80 TRANSMISSION — ROLL PIN REPLACEMENT

### OVERVIEW

In some of the affected vehicles, the roll pin attaching the transmission shift linkage to the transmission may come out. If this happens, movement of the shift lever by the driver will not change the transmission gear state. The transmission will remain in the gear it was in when the pin came out regardless of the position of the shift lever.

If the roll pin comes out, a driver may experience any of the following:

- A loose or low effort feel of the shift lever.
- If the vehicle is equipped with a floor shifter, the shifter indicator could display inaccurate gear position.
- When exiting the vehicle, if the transmission is not in Park, the ignition key can be removed, but a warning chime will sound and a message will be displayed in the instrument cluster indicating Transmission Not in Park.
- If the transmission is not in Park or Neutral, the driver would not be able to restart the vehicle.
- If the vehicle cannot be shifted to Park and the parking brake is not applied, unintended vehicle movement may occur, increasing the risk of accident or injury.

Before demonstrating or delivering any new in-stock vehicles involved in this recall, dealers are to replace the transmission shift linkage roll pin.

**When operating affected vehicles prior to repair, make sure the parking brake is applied whenever the vehicle is parked.**

### SERVICE PROCEDURE

#### Recommended Tool List:

1/4" Drive 8mm and 10mm Mid-length Socket	3/8" Drive Extension 10 in (254 mm)
3/8" Drive 19mm Socket	10mm and 8mm Flex Head Ratchet Wrench
3/8" Drive 13mm Crows Foot	3/16" Punch
1/4" and 3/8" Drive Ratchet (Hand and Power)	Trim/Push Pin Removal Tool
1/4" Universal Joint	Pocket screw driver
1/4" Drive Extension 6 in (152 mm)	Hammer
3/8" Drive Torque Wrench	



1. Remove the transmission fluid pan. Please follow the Workshop Manual (WSM) procedures in Section 307-01B.

**NOTE:** Mark the new roll pin at 3 mm (0.11 in) up from the bottom (opposite the tapered end) to aid installation.

2. Replace the transmission manual control shaft-to-transmission range sensor roll pin. See Figure 1.

- When installing the new (revised) roll pin, insert tapered end first. Then drive the roll pin into the manual control lever shaft until 3 mm (0.11 in) of the roll pin remains out of the bottom of the shaft.

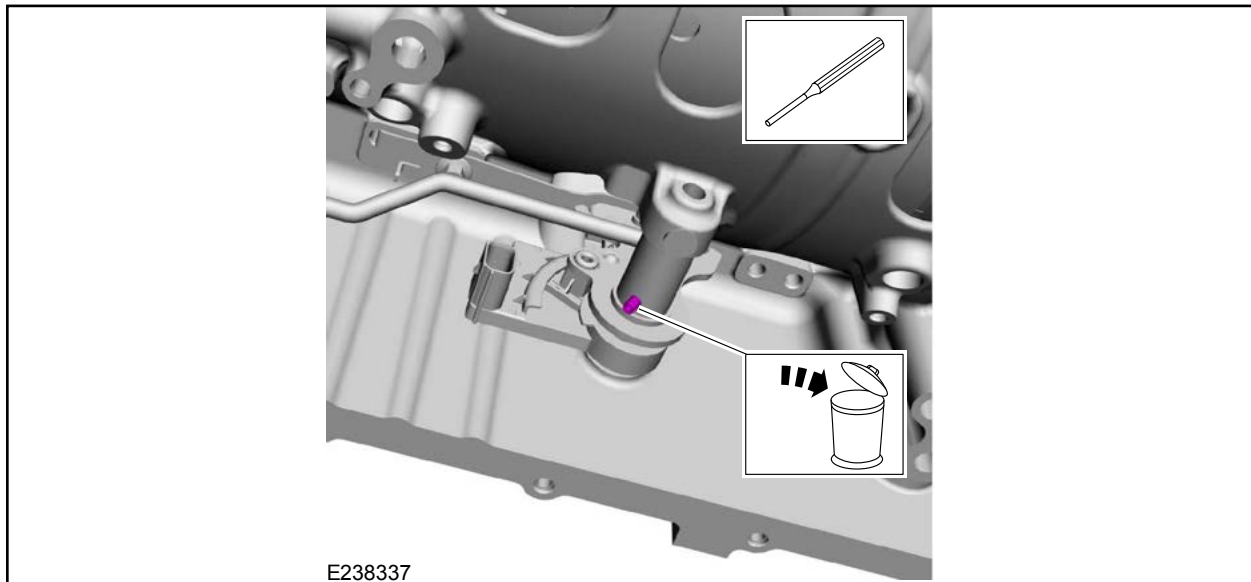

**FIGURE 1**

3. Install the transmission fluid pan. Please follow the Workshop Manual (WSM) procedures in Section 307-01B.

