

SPRINTER

MERCEDES-BENZ USA, LLC
303 Perimeter Center North, Suite 202
Atlanta, GA, 30346
Phone: (770) 705-0600
Fax: (770) 705-0117
MBUSA.com



newschannel update

TO: : Mercedes-Benz Dealer Principals, General Managers, Sales Managers, Service Managers, Parts Managers	FROM: Michael Scott, Vans Regulations and Certifications Gregory Gunther, Department Manager, Vehicle Compliance and Analysis, Engineering Services
RE: Recall Campaign 2017110001 Launch Notification MY16 MY17 447 (Metris) Replace EPS Rack	DATE: December 15, 2017

IMPORTANT RECALL LAUNCH INFORMATION





RECALL CAMPAIGN LAUNCH NOTIFICATION

December 15, 2017

Campaign No. :	Campaign Desc. :	Replace EPS Rack
2017110001	VS2EPSLENK	
<p>This is to notify you of the Recall Campaign Launch to replace the electric power steering (EPS) rack on 3 MY16 and MY17 Metris (447) vehicles. Please review the recall information below. The recall campaign will be visible on the www.safercar.gov website and may generate questions from customers. All affected VINs will be flagged as "OPEN" in VMI on December 15, 2017.</p>		
Background		
Issue	Daimler AG ('DAG'), the manufacturer of Mercedes-Benz Metris vehicles, has determined that on certain MY16 and MY17 447 Metris vans, the electrical contacts in the control module of the electric power steering rack may not have been properly welded. If the pins completely lose contact, the electric power steering assist may deactivate, increasing the risk of a crash.	
What We're Doing	MBUSA will conduct a voluntary recall. An authorized Mercedes-Benz Metris dealer with replace the electric power steering rack on the affected vehicles.	
Parts	Parts are available and may be ordered.	
Vehicles Affected		
Vehicle Model Year(s)	2016, 2017	
Vehicle Model	Metris	
Vehicle Populations		
Total Recall Population	3	
<p>Given this notice, it is a violation of Federal law for a dealer to sell or lease any new MY16 or MY17 Metris vehicles in dealer inventory covered by this notification until the vehicle has been repaired. The vehicles will be flagged as "OPEN" and Work Instructions will be available in Star TekInfo. Once the repair is complete, the vehicle may be sold or leased.</p> <p style="text-align: center;">Loaner and demonstrator vehicles may continue to be driven, but must not be retailed until repaired.</p> <p>Additionally, given this notice, it is a violation of Federal Law for rental companies to rent new MY16 or MY17 Metris vehicles covered by this notification until the vehicle has been repaired.</p>		
Next Steps/Notes		
Customer Notification Timeline	Customer interim letters were mailed November 17, 2017. Final letters will be mailed December 21, 2017.	
AOMS/SOMS	AOMs – This recall may generate questions from your dealers.	
<p>While we regret any inconvenience this may cause, MBUSA is determined to maintain a high level of vehicle quality and customer satisfaction. Please refer all customer inquiries to the Customer Assistance Center at 1-800-FOR-MERCEDES.</p>		



Mercedes-Benz

Campaign No. 2017110001, November 2017

TO: ALL MERCEDES-BENZ CENTERS

SUBJECT: **Model 447 Model Year 2017**
Replace Electric Power Steering Rack

Daimler AG ('DAG'), the manufacturer of Mercedes-Benz Metris vehicles, has determined that on certain MY17 447 Metris vans, the electrical contacts in the control module of the electric power steering rack may not have been properly welded. If the pins completely lose contact, the electric power steering assist may deactivate, increasing the risk of a crash.

Prior to performing this Recall Campaign:

- Please check VMI to determine if the vehicle is involved in the Campaign and if it has been previously repaired.
- Please review the entire Recall Campaign bulletin and follow the repair procedure exactly as described.

Please note that Recall Campaigns **do not expire** and may also be performed on a vehicle with a vehicle status indicator.

Approximately 3 vehicles are involved.

Order No. V-RC-2017110001

This bulletin has been created and maintained in accordance with MBUSA-SLP S423QH001, Document and Data Control, and MBUSA-SLP S424HH001, Control of Quality Records.

Procedure

1.  Replace electric power steering rack.

 For basic data see **AR46.20-S-0500E**.

-  After having replaced the steering, the serial number of the new steering gear **must** be documented in **VeDoc**. See **SI46.00-P-0001A** for more information

Primary Parts Information

Qty.	Part Name	Part Number	Estimated Replacement Rate
1	Power steering rack	A 447 460 37 00	100%

 **Note** (regarding WIS documents referenced in this Procedure): Replacement of parts not listed in the parts table of this Procedure are not claimable under this campaign. If replacement of additional part(s) is necessary, check coverage prior to submitting under warranty.

 **Note:**

- Please be aware that only the part number(s) referenced in the Campaign Bulletin is/are approved for use to repair the vehicle. Repairs performed using any other part(s) will not have been performed in accordance with the campaign. Accordingly, warranty claims submitted with reference to an improper part number(s) will be denied.
- The following allowable labor operation should be used when submitting a warranty claim for this repair:

Special Tools

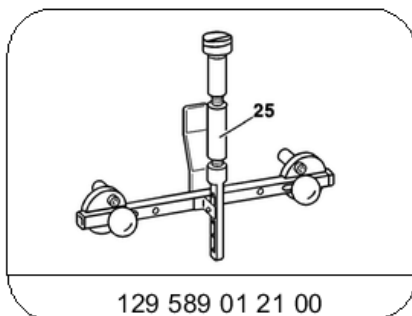

Retainer device

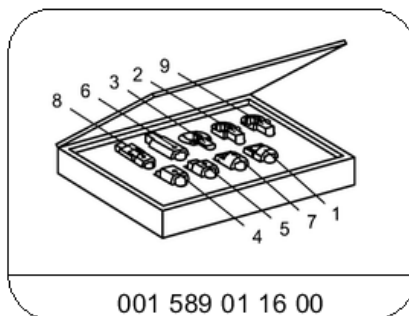

Engine mount wrench set

Warranty Information

Operation: Replace power steering rack (02-2113).
(Includes: Remove/install engine compartment lining in vehicles with underbody Protection and alignment of front wheels).

Damage Code	Operation Number	Labor Time (hrs.)
54 952 80 7	02 9975	3.0

i **Note**

Operation Number labor times are subject to change.