



MERCEDES-BENZ USA, LLC
303 Perimeter Center North, Suite 202
Atlanta, GA, 30346
Phone: (770) 705-0600
Fax: (770) 705-0117
MBUSA.com



newschannel update

TO: Mercedes-Benz Dealer Principals, General Managers, Sales Managers, Service Managers, Parts Managers	FROM: Gregory Gunther, Department Manager, Vehicle Compliance and Analysis, Engineering Services
RE: Recall Campaign Launch Notification Replace EPS Rack MY17 205 213 253 (C-Class, E-Class, GLC-Class)	DATE: November 3, 2017

IMPORTANT NEW RECALL CAMPAIGN LAUNCH INFORMATION





RECALL CAMPAIGN LAUNCH NOTIFICATION

November 3, 2017

Campaign No. :	Campaign Desc. :	Replace EPS Rack
2017100004	1709P46C33	
<p>This is to notify you of a new Recall Campaign to replace the electric power steering ('EPS') rack on 4 MY 2017, Model 205, 213, 253 (C-Class, E-Class, GLC-Class) vehicles. Please review the recall information below. The recall campaign will be visible on the www.safercar.gov website and may generate questions from customers. Affected VINs will be flagged in VMI as "OPEN" on November 3, 2017.</p>		
Background		
Issue	Daimler AG ('DAG'), the manufacturer of Mercedes-Benz vehicles, has determined that in certain C-Class (205 platform), E-Class (213 platform) and GLC (253 platform) vehicles, the contacts inside the electric power steering control unit might not have been properly welded. If the pins completely lose contact, the electric power steering assist will deactivate, increasing the risk of a crash.	
What We're Doing	MBUSA will conduct a voluntary recall. An authorized Mercedes-Benz dealer will replace the EPS rack on the affected vehicles.	
Parts	Parts are currently available and can be ordered as necessary	
Vehicles Affected		
Vehicle Model Year(s)	2017	
Vehicle Model	C-Class, E-Class, GLC-Class	
Affected VIN(s)	55SWF6EB2HU192622, WDDZF4KB7HA129120, WDDZF6EB9HA213429, WDC0G4JBXHF230277	
Vehicle Populations		
Total Recall Population	4	
Total Vehicles in Dealer Inventory	0	
<p>Given this notice, it is a violation of Federal law for a dealer to sell or lease any new MY17 C-Class, E-Class, or GLC-Class vehicles in dealer inventory covered by this notification until the vehicle has been repaired. Once remedy parts are available, the vehicles will be flagged as "OPEN" and Work Instructions will be available in Star TekInfo. Once the repair is complete, the vehicle may be sold or leased.</p> <p style="text-align: center;">Loaner and demonstrator vehicles may continue to be driven, but must not be retailed until repaired.</p> <p>Additionally, Given this notice, it is a violation of Federal Law for car rental companies to rent new MY17 C-Class, E-Class, or GLC-Class vehicles covered by this notification until the vehicle has been repaired.</p>		
Next Steps/Notes		
Customer Notification Timeline	Customer notification letters are scheduled to be mailed in early November 2017.	
AOMS/SOMS	AOMs – This recall may generate questions from your dealers. Please forward this notice to your dealers ASAP.	
Rental Fleet Partners	This recall may affect vehicles in your fleet. Please contact your respective MBUSA fleet representative for further information and next steps. For repairs, please contact your preferred MBUSA dealer.	
<p>While we regret any inconvenience this may cause, MBUSA is determined to maintain a high level of vehicle quality and customer satisfaction. Please refer all customer inquiries to the Customer Assistance Center at 1-800-FOR-MERCEDES.</p>		



Mercedes-Benz

Campaign No. 2017100004, November 2017

TO: ALL MERCEDES-BENZ CENTERS

SUBJECT: **Models 205, 213, and 253 Model Year 2017**
Replace Electric Power Steering Rack

Daimler AG ('DAG'), the manufacturer of Mercedes-Benz vehicles, has determined that in certain C-Class (205 platform), E-Class (213 platform) and GLC (253 platform) vehicles, the contacts inside the electric power steering control unit might not have been properly welded. If the pins completely lose contact, the electric power steering assist will deactivate, potentially increasing the risk of a crash. An authorized Mercedes-Benz dealer, will replace the electric power steering rack on the affected vehicles.

Prior to performing this Recall Campaign:

- Please check VMI to determine if the vehicle is involved in the Campaign and if it has been previously repaired.
- Please review the entire Recall Campaign bulletin and follow the repair procedure exactly as described.

Please note that Recall Campaigns **do not expire** and may also be performed on a vehicle with a vehicle status indicator.

Approximately 4 vehicles are involved.

Order No. P-RC-2017100004

This bulletin has been created and maintained in accordance with MBUSA-SLP S423QH001, Document and Data Control, and MBUSA-SLP S424HH001, Control of Quality Records.

Procedure

1.  Replace electric power steering rack.

 For basic data see **AR46.20-P-0600LW**.

 After having replaced the steering, the serial number of the new steering gear **must** be documented in **VeDoc**. See **SI46.00-P-0001A** for more information

Primary Parts Information

Qty.	Part Name	Part Number	Estimated Replacement Rate
Models 205.064			
1	Power steering rack	A205 460 11 02	100%
Models 213.049			
1	Power steering rack	A213 460 50 01	100%
Model 213.064			
1	Power steering rack	A213 460 61 01	100%
Model 253.948			
1	Power steering rack	A253 460 70 00	100%

 **Note** (regarding WIS documents referenced in this Procedure):

Replacement of parts not listed in the parts table of this Procedure are not claimable under this campaign. If replacement of additional part(s) is necessary, check coverage prior to submitting under warranty.

 **Note:**

- Please be aware that only the part number(s) referenced in the Campaign Bulletin is/are approved for use to repair the vehicle. Repairs performed using any other part(s) will not have been performed in accordance with the campaign. Accordingly, warranty claims submitted with reference to an improper part number(s) will be denied.
- The following allowable labor operation should be used when submitting a warranty claim for this repair:

Special Tools

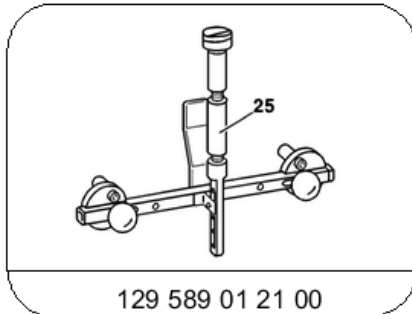

129 589 01 21 00

Retainer device

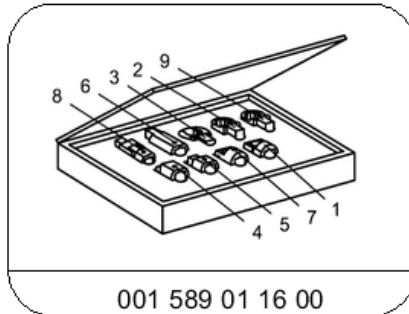

001 589 01 16 00

Engine mount wrench set

Warranty Information

Operation: Replace power steering rack (02-2113).
 Extra work for: Remove/install engine compartment lining in vehicles with underbody protection (02-9676)
 Perform wheel alignment check (02-9785)
 (Includes: Adjust track of front wheels).

Damage Code	Operation Number	Labor Time (hrs.)
46 941 38 7	02-2113	1.8 (models 205,253)
		1.9 (model 231)
	02-9676	ZM
	02-9785	0.9

Note

Operation Number labor times are subject to change.