

ATTACHMENT A



Tie Rod Arm Taper Inspection Procedure

Steer Axle Models Affected:

E1202I	D1461I
E1202W	D850F
E1202IC	E1234WC
E1202XW	E1462I
E1002I	E1462W
E1002W	E1462XW
E1002XW	D600
E1302I	D700F
E1302W	D800
E1322I	D800F
E1322IC	D850B
E1322W	D2000F
E1322XW	D2000W
EFA-20F4	D2200F
I160W	D2200W
I180W	E1402I
I200W	

Inspection Procedure:

1. Block the forward and rear of at least one of the drive axle tires so the vehicle cannot move during this procedure.
2. With a flexible, magnetic base dial indicator, mount the base of the indicator on the tie rod arm so that the indicator tip can be centered on the threads of the stud just above the nut.



Dial Indicator Mounting Position

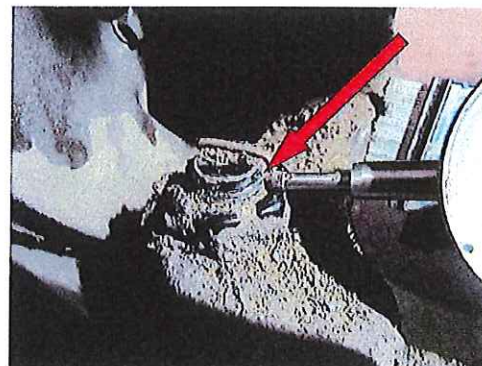

Dial Indicator Tip Must be Placed on The Stud

3. With someone in the cab of the truck turning the steering wheel (engine off) just enough to cause movement in the wheels, document how much movement is found on each side of the steer axle. Record results on the supplied spreadsheet.

- The next step is to remove the cotter pins and check for proper nut torque. Put a paint mark across one side of the nut and top of the stud. With a DIAL torque wrench and a 1 ¼" socket, torque the nut in a clockwise (tighten) direction until the nut just starts to rotate or you reach 130 ft. lbs. **Important: Do not exceed 170 ft. lbs.** Record your findings on the spreadsheet.

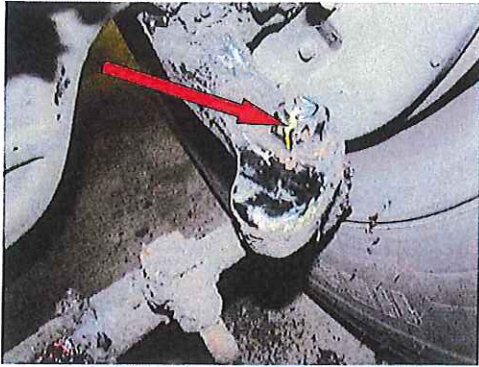

Paint Mark to Identify Nut Rotation

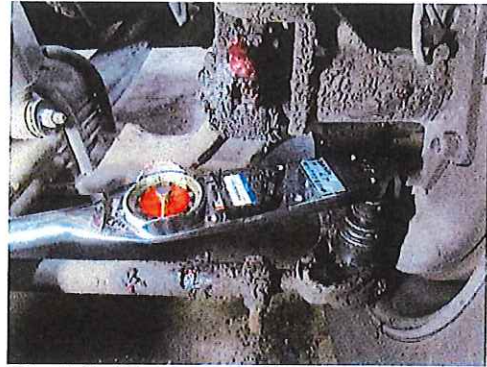

Check Nut Torque – Do Not Exceed 170 ft. lbs.

- If there is no rotation of the nut at 130 ft. lbs. install a new cotter pin and return the truck to service.

- If you found rotation of the nut before you reached 130 ft. lbs., we can now torque the nut to 130 ft. lbs. Using the paint mark, record the amount of movement to the nut. Example: Use the paint mark as the 12:00 position, if the nut rotates ¼ turn to reach 130 ft. lbs., document the nut rotated as the 3:00 position.

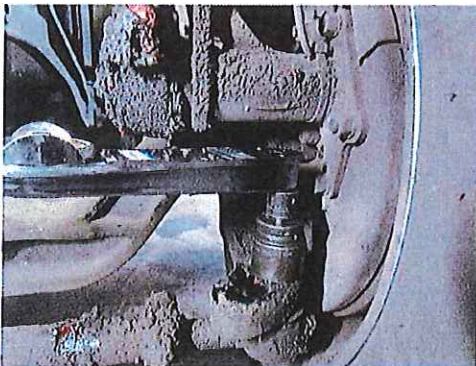

Retorque to 130 ft. lbs.

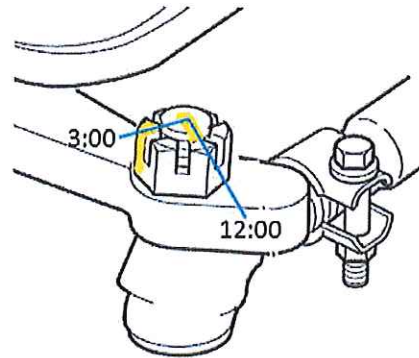

Record Rotation on Nut

- With the nut torque to 130 ft. lbs. advance the nut so that the cotter pin hole is aligned with a slot in the nut, reinstall the dial indicator and check for tie rod stud movement once again. Record results.
Note: Never back the nut off to align the cotter pin hole to the nut slot. Torque may reach 170 ft. lbs. to obtain proper alignment.
- Important:** Any tie rod stud with movement after proper nut torque and alignment will require the replacement of that knuckle and tie rod assembly.
- Important:** One last check. After the nut has been aligned with a slot in the nut, the cotter pin hole **CAN NOT** be above the top of the nut as shown below. Any cotter pin hole that is above the top of the nut surface will require the replacement of the knuckle and tie rod end assemblies.

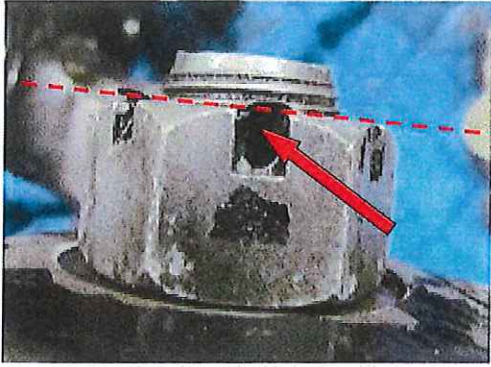

Good Cotter Pin Hole Position

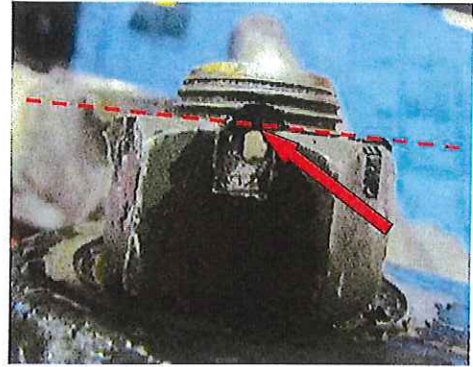

Cotter Pin Hole at Maximum Height