



MERCEDES-BENZ USA, LLC
303 Perimeter Center North, Suite 202
Atlanta, GA, 30346
Phone: (770) 705-0600
Fax: (770) 705-0117
MBUSA.com

Service

newschannel update

TO: Mercedes-Benz Dealer Principals, General Managers, Sales Managers, Service Managers, Parts Managers

FROM: Thomas Brunner, Department Manager, Vehicle Compliance and Analysis, Engineering Services

RE: **Recall Campaign 2017050024
Launch Notification**
MY17 205, 222, 253 (C-Class, GLC-Class, S-Class)
Mix Ratio Front Seatbelt Pre-tensioner (Driver)

DATE: September 22, 2017

IMPORTANT RECALL CAMPAIGN LAUNCH INFORMATION UPDATE





RECALL LAUNCH CAMPAIGN NOTIFICATION

REMEDY PARTS AVAILABLE

September 22, 2017

Campaign No. :	Campaign Desc. :	Replace Front Seatbelt (Driver)
2017050024	1704P91A95	
<p>This is to notify you of an update to the Recall Campaign for certain Model Year 2017 205, 222, 253 platform vehicles (C-Class, GLC-Class, S-Class). Please review the recall information below. The recall campaign will be visible on the www.safercar.gov website and may generate questions from customers. Please note that this update only accounts for a subset of a larger recall population initially identified in a prior NCU distributed on May 2, 2017.</p>		
Background		
Issue	Daimler AG ("DAG"), the manufacturer of Mercedes-Benz vehicles, has determined that on certain C-Class, GLC-Class, and S-Class vehicles (205, 222, 253 platform) the propellant mix ratio in certain seat belt pre-tensioner igniters might not meet manufacturing specifications. Thus, in the event of a crash, the igniters might not deploy in situations where the front seat belt pre-tensioners are activated, increasing the risk of injury to the occupants.	
What We're Doing	MBUSA will conduct a voluntary recall. An authorized Mercedes-Benz dealer will replace the potentially affected driver's seat belt on the affected vehicles.	
Parts	Parts are available and can be ordered as necessary	
Vehicles Affected		
Vehicle Model Year(s)	2017	
Vehicle Model	C-Class, S-Class, GLC-Class	
Vehicle Populations		
Total Recall Population	2183	
Total Vehicles in Dealer Inventory	346	
<p>Given this notice, it is a violation of Federal law for a dealer to sell or lease any new MY17 C-Class, S-Class, or GLC-Class vehicles in dealer inventory covered by this notification until the vehicle has been repaired. Once remedy parts are available, the vehicles will be flagged as "OPEN" and Work Instructions will be available in Star TekInfo. Once the repair is complete, the vehicle may be sold or leased.</p> <p style="text-align: center;">Loaner and demonstrator vehicles may continue to be driven, but must not be retailed until repaired.</p> <p>Additionally, given this notice, it is a violation of Federal Law for car rental companies to rent new MY17 C-Class, S-Class, or GLC-Class vehicles covered by this notification until the vehicle has been repaired.</p>		
Next Steps/Notes		
Customer Notification Timeline	Customer notification letters are scheduled to be mailed in early October 2017.	
AOMS/SOMS	AOMs – This recall may generate questions from your dealers. Please forward this notice to your dealers ASAP.	
Rental Fleet Partners	This recall may affect vehicles in your fleet. Please contact your respective MBUSA fleet representative for further information and next steps. For repairs, please contact your preferred MBUSA dealer.	
<p>While we regret any inconvenience this may cause, MBUSA is determined to maintain a high level of vehicle quality and customer satisfaction. Please refer all customer inquiries to the Customer Assistance Center at 1-800-FOR-MERCEDES.</p>		



Mercedes-Benz

Campaign No. 2017050024, July 2017
Revision B

TO: ALL MERCEDES-BENZ CENTERS

SUBJECT: **Model 205, 253, and 222, Model Year 2017**
Replace Left Front Seat Belt

Daimler AG ('DAG'), the manufacturer of Mercedes-Benz vehicles, has determined that on certain C-Class, S-Class, and GLC-Class vehicles (253,205,222 platform) the propellant mix ratio in certain seat belt pre-tensioner igniters might not meet manufacturing specifications. As a result, the igniters may not sufficiently deploy in situations where the front seat belt pre-tensioners are activated, decreasing the restraining capabilities of the seatbelts, increasing the risk of injury to occupants in the event of a crash. An authorized Mercedes-Benz dealer will replace the left front seatbelt on affected vehicles.

Prior to performing this Recall Campaign:

- Please check VMI to determine if the vehicle is involved in the Campaign and if it has been previously repaired.
- Please review the entire Recall Campaign bulletin and follow the repair procedure exactly as described.

Please note that Recall Campaigns **do not expire** and may also be performed on a vehicle with a vehicle status indicator.

Approximately 2182 vehicles are involved.

Order No. P-RC-2017050024

This bulletin has been created and maintained in accordance with MBUSA-SLP S423QH001, Document and Data Control, and MBUSA-SLP S424HH001, Control of Quality Records.

Procedure



WARNING!

There is a risk of injury or death when performing testing or repair work on vehicles and when handling vehicle components. Be sure to read and observe all relevant safety instructions in WIS. This procedure must only be performed by trained personnel using proper tools and equipment.

1. Start engine and check whether Supplemental Restraint System (SRS) indicator lamp (arrow, Figure 1) goes out after a few seconds.

i **Note:** Prior to replacing seat belt, it must be ensured that:

- No errors are active in the SRS system (as described in this step).
- No SRS error messages are active in the instrument cluster (as described in this step).
- If an SRS error message is pending before start of work, it must be corrected. Fault corrections (repairs) are not claimable under this campaign.

2. Replace seat belt for left front seat.



For basic data for model 205.0/1/2 and 253, see AR91.40-P-1010LW



For basic data for model 205.4, see AR91.40-P-1010LWR



For basic data for model 205.3, see AR91.40-P-1010CLW



For basic data for model 222, see AR91.40-P-1010LF



As opposed to the WIS work instructions, it is not necessary to check the supplemental restraint system with XENTRY/DAS after seat belt replacement



Note: Disconnect negative battery cable prior to removing seat belt.



Figure 1 (shown on model 213)



Figure 2 (shown on right front seat belt)

3. Supplemental information to above WIS instructions:

- Remove screw (A, Figure 2).
- **Hm** Upon installation, torque screw (A) to: 4 Nm.
- Remove retaining clamp (B).
- Pull seat belt (C) toward front (arrow) out of guide at front seat.

4. Install **new** seat belt and pretensioner in reverse order.

i **Note:**

- Ensure seat belt is not twisted.
- Ensure that all applicable steps in the referenced WIS instructions are completed.

5.  After installation of new seat belt be sure to start engine and check whether SRS indicator lamp goes out after a few seconds (arrow, Figure 1).

i **Note:**

- Requested parts must be returned to the designated QEC test center in accordance with the warranty parts return requirements section found in the policy and procedures manual.
- Use the attached hazmat shipping document as a guide for shipping seat belts.

i **Note** (regarding WIS documents referenced in this Procedure):

Replacement of parts not listed in the parts table of this Procedure are not claimable under this campaign. If replacement of additional part(s) is necessary, check coverage prior to submitting under warranty.

Primary Parts Information

Qty.	Part Name	Part Number	Estimated Replacement Rate
1	Left front seat belt	*	100%

* Determine part number with chassis number and equipment code in EPC.

i Note:

Please be aware that only the part number(s) referenced in the Campaign Bulletin is/are approved for use to repair the vehicle. Repairs performed using any other part(s) will not have been performed in accordance with the campaign. Accordingly, warranty claims submitted with reference to an improper part number(s) will be denied.

- Please be aware that the entire seatbelt assembly must be ordered and used for the recall repair. The pre-existing seatbelt should not be reinstalled in the vehicle. The repair must be completed with a new seatbelt and pretensioner module included.

Warranty Information

Operation: Replace left front seat belt (02-9980).
 Connect/disconnect battery charger (02-5058)
 Star Diagnosis System (SDS), Connect/disconnect (02-4762)

Damage Code	Operation Number	Labor Time (hrs.)
91 902 02 7	02-9980 (253)	0.9
	02-9980 (205.0/1/2)	0.9
	02-9980 (205.3)	1.7
	02-9980 (205.4)	1.6
	02-9980 (222)	0.9
	02-5058	0.1
	02-4762	0.1

i Note

Operation Number labor times are subject to change.

Special Tools

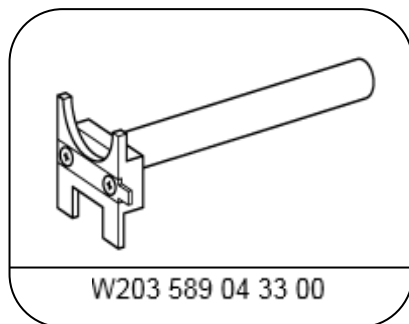

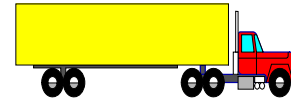

Hazardous Materials Shipping Instructions - GROUND

Part Name: Airbag Part Number: Several	Hazardous Properties: Contains initiating component which deploys (inflates) airbag.
---	---

STRAIGHT BILL OF LADING
ORIGINAL - NOT NEGOTIABLE

PIECES	IN	HM	DESCRIPTION	WEIGHT	RATE	CHARGES	CLASS
1 box		X	UN3268, Safety devices, 9	<i>Write gross weight of box here</i>			

This is to certify that the above-named materials are properly classified, described, packaged, marked and labeled, and are in proper condition for transportation according to the applicable regulations of the Department of Transportation.

SHIPPER HazMat Employee Signs	CARRIER Name of Carrier
EMERGENCY CONTACT: CHEMTREC 1-800-424-9300	

Steps to Return an Airbag:

REQUIRED PACKAGING:

- Carefully open received box and remove new airbag. Keep box intact & save all contents!
- Place used airbag into replacement UN specified 4G fiberboard box, re-using any packaging material (e.g., cardboard inserts) used for the new airbag. Package exactly as the new airbag was packaged.
- Use plastic adhesive tape 50 mm wide to secure the box closed. Do not obscure labels or text on the box with the tape.
- Ensure that the 4G fiberboard box is not ripped or damaged.

REQUIRED LABELS:

- A **Class 9 Miscellaneous** label must be clearly visible on one side of the box.

REQUIRED PACKAGE MARKINGS:

- The following words ("marking") must also be clearly visible on the same side of the box as the Class 9 label:
Safety devices
UN3268 (font size must be $\geq 1/2$ inch)
- Affix **"To/From"** address label to same or adjacent packaging face as the hazardous markings/labels.
- The UN 4G code preprinted near the bottom edge of the box must also be clearly visible.

REQUIRED DOCUMENTATION:

- Include a HAZMAT bill of lading (see above example) with the package. For returns via DDS or FedEx Ground, the system will generate the Hazmat bill of lading.

COMMENTS:

- Note:** The Packing Group and the EX# are no longer required to be printed on the HAZMAT bill of lading.
- Package example:**



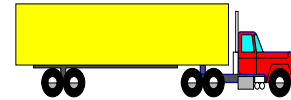

Hazardous Materials Shipping Instructions for shipments using an Overpack - GROUND

Part Name: Airbag	Hazardous Properties: Contains initiating component which deploys (inflates) airbags.
Part Number: A906 860 00 02 9051	

STRAIGHT BILL OF LADING ORIGINAL - NOT NEGOTIABLE

PIECES	IN	HM	DESCRIPTION	WEIGHT	RATE	CHARGES	CLASS
1 box		X	UN3268, Safety devices, 9 OVERPACK USED	<i>Write gross weight of box here</i>			

This is to certify that the above-named materials are properly classified, described, packaged, marked and labeled, and are in proper condition for transportation according to the applicable regulations of the Department of Transportation.

SHIPPER HazMat Employee Signs	CARRIER Name of Carrier
EMERGENCY CONTACT: CHEMTREC 1-800-424-9300	

Steps to Return Multiple Airbags in 1 Box: REQUIRED PACKAGING:

- Carefully open received UN spec box and remove new airbag. Keep the box intact & save all contents!
- Place used airbag back into replacement airbag box, re-using any packaging material (e.g., cardboard inserts) used for the new airbag. Package as the new airbag was packaged.
- Use plastic adhesive packaging tape 50 mm wide to secure box closed. Do not obscure labels or text on box with tape.

REQUIRED LABELS:

- A Class 9 Miscellaneous label must be clearly visible on one side of the box.

REQUIRED PACKAGE MARKINGS:

- The following words ("markings") must also be clearly visible on the same side of the box as the label:

Safety devices
UN3268 (font size must be $\geq \frac{1}{2}$ inch)

- Affix "To/From" address label to same or adjacent packaging face as the hazardous markings/labels.
- The UN 4G code preprinted near the bottom edge of the box must also be clearly visible.

OVERPACKS (more than 1 airbag sent as 1 shipment):

- Package each airbag in a separate UN spec box prepared with the labels/markings described above.
- Place each individual airbag box inside a larger non-UN spec box to keep the shipment together.
- This larger box is called an "OVERPACK."
- The OVERPACK must have the identical markings and label as the boxes contained inside.

- The OVERPACK must have the "OVERPACK" statement on the same face as the hazard markings and labels.

Package example:

