

# SAFETY RECALL: SERVICE BULLETIN 546 - HEATED GRIP SPACER



## Notice Information

Ref: 1720  
 Posted Date: 1/25/2017 10:16:56 AM  
 Posted To: Dealer Principal, Service / Technical, Motorcycle Sales, Franchise/Brand Manager, Sales Manager, Workshop Manager, Service Reception, Dealer Admin  
 Subject: Service/Technical

## TOL NOTICE (US&CAN) – January 25, 2017

### **SAFETY RECALL: Service Bulletin 546 – Heated Grip Spacer**

Triumph has released a Service Bulletin (SB546) with information on the need to add a new spacer between the end weight and handlebar on the right-hand side (throttle side) of Bonneville T120 & Bonneville T120 Black models in the affected VIN range. Motorcycles in the affected VIN range must be modified prior to delivery to the customer, or at the next visit to the dealership.

<b>SERVICE BULLETIN 546: HEATED GRIP SPACER</b>		
<b>Bulletin Number</b>	<b>Models Affected</b>	<b>VIN Range</b>
546	Bonneville T120	From 739727 to 776237
	Bonneville T120 Black	From 741136 to 776237

The addition of this new spacer (see Item 3 in diagram below) will ensure a sufficient expansion air-gap between the end of the throttle twist grip rubber and the end weight. The air-gap is required to accommodate the expansion of the rubber grip when the rider switches the heated grips to “on”. When turned “on” an insufficient air-gap may cause the (activated heated) throttle twist grip to bind on the end weight. Under these circumstances this may prevent the twist grip from returning to its positive stop without manual intervention by the rider. This symptom will not occur on a cold grip or models without heated grips.

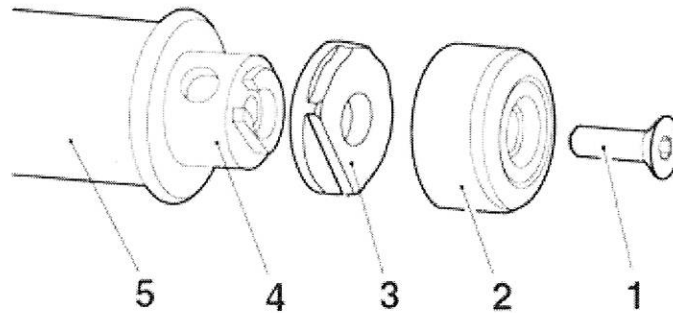

1. Fixing
2. Handlebar end weight
3. Spacer
4. Handlebar
5. Heated twist grip

All affected motorcycles are to be repaired in accordance with SB546. Please see attached **SB546 - Heated Twist Grip** PDF or visit the Service Bulletin library on **Triumphonline.net (TOL)** to access SB546, then print off the new bulletin for your workshop files and ensure all appropriate staff are made aware of contents.

*Note: This is currently provided in English only. Non-English versions will follow in the next few days.*

***It is also imperative that any owner having recently purchased an affected machine should be contacted by you immediately and asked to return the machine for modification. We require you to immediately quarantine any unsold or uncollected machines and arrange their modification prior to any further deliveries to customers. You may wish to use Triumphonline.net to assist you in identifying unsold stock.***

You may have several affected bikes ready for collection. Please submit new warranty priors for these bikes in order that we may supply you the necessary parts. We trust you will be able to repair any bikes prior to handover. WOL includes full details.

Parts supply is initially limited. We therefore ask for your cooperation to ensure we utilize the spare parts we do have in the most optimal manner. Please only submit warranty New Priors (which also places a parts order to Triumph) for motorcycles already sold to customers or about to be handed over as a new bike sale. Do not order parts for unsold dealer stock until advised that we have the necessary parts in stock.

**Dealer Action:**

1. Quarantine all unsold stock and arrange modification. You can check those machines in your unsold stock that require modification by using Triumphonline.net. Do this by undertaking the following simple steps: Once signed into the site, select Motorcycle Sales and then Stock Management (this will provide you a display summary of your unsold machines by model). Select the affected model to view the individual VIN details of your unsold machines. We strongly recommend you check this listing against your physical stock and advise us of any discrepancies. Machines containing a symbol of a 'wrench' (indicating Bulletin outstanding) will require attention. Select the VIN to open a dialogue window. Details of all outstanding bulletin(s) are contained in the bottom half of the screen. To view the bulletin content, click on the Union Jack 'flag' to open an English language PDF document or alternative flags for other language options (when available). This can be read and/or printed off as required.
2. Please note some VINs affected by this bulletin may also require other bulletin work to be carried out. Please use the above described system tools to identify ALL outstanding Service Bulletins and make arrangements to carry out these repairs at the same time.
3. Read, download and circulate the above mentioned Service Bulletin 546 to relevant staff.
4. Ensure all sales and service staff are aware of this action.
5. Owners of machines outside of the affected VIN range are not connected with this action and may therefore require reassurance.
6. Ensure removed parts are correctly identified, securely stored and scrapped as described in the Service Bulletin instructions.
7. This action is likely to increase visitors to your showroom and service areas. Please ensure all arrangements are made to best accommodate them.

**Triumph Action:**

1. A copy of the Service Bulletin 546 will be posted onto Triumphonline.net in the next 24 hours.

2. All arrangements for the updating of our computer systems will be completed tomorrow.
  
3. Notification letter to current customers are to be mailed beginning on January 27, 2017, explaining the action and also advising that the modification will be carried out free-of-charge to the owner.

We apologize if this unexpected workload inconveniences you in any way and thank you for your cooperation. If you have any questions, please contact Triumph 24/7 Customer Support at (888) 284-6288.

---

Triumph Motorcycles (America) Ltd, 100 Hartsfield Centre Parkway, Suite 200, Atlanta Georgia, 30354, UNITED STATES  
Tel: 001 6788 542010, Fax: 001 6788 542025

